

**Final  
Quality Assurance Project Plan  
Former Fort Ord, California**

**Volume II  
Appendix C  
Prescribed Burn Air Monitoring**

**Worldwide Environmental Remediation Services Contract  
Contract No. W912DY-10-D-0027  
Task Order No. CM01**

Prepared for:  
United States Army Corps of Engineers  
Sacramento District  
1325 J Street  
Sacramento, California 95814

Prepared by:  
KEMRON Environmental Services Inc.  
1359-A Ellsworth Industrial Boulevard  
Atlanta, GA 30318

## TABLE OF CONTENTS

TABLE OF CONTENTS.....	ii
ABBREVIATIONS AND ACRONYMS .....	iv
EXECUTIVE SUMMARY .....	vi
<b>1.0 PROJECT MANAGEMENT.....</b>	<b>1</b>
1.1 Title and Approval Page (QAPP Worksheets #1 & 2).....	1
1.2 Project Organization and QAPP Distribution (QAPP Worksheets #3 & 5) .....	4
1.3 Personnel Qualifications and Sign-off Sheet (QAPP Worksheets #4, 7, & 8).....	5
1.4 Communication Pathways (QAPP Worksheet #6).....	8
1.5 Project Planning Session Summary (QAPP Worksheet #9) .....	9
<b>2.0 PROJECT QUALITY OBJECTIVES .....</b>	<b>10</b>
2.1 Conceptual Site Model (QAPP Worksheet #10).....	10
2.2 Project Data Quality Objectives (QAPP Worksheet #11).....	13
2.3 Measurement Performance Criteria Table (QAPP Worksheet #12) .....	19
2.4 Secondary Data Uses and Limitations Table (QAPP Worksheet #13) .....	21
2.5 Project Tasks and Schedule (QAPP Worksheets #14 and #16).....	23
2.6 Project Action Limits and Laboratory-Specific Detection/Quantitation Limits (QAPP Worksheet #15).....	27
<b>3.0 SAMPLE DESIGN (QAPP Worksheet #17).....</b>	<b>28</b>
3.1 Sampling Locations and Methods (QAPP Worksheet #18).....	29
<b>4.0 SAMPLING REQUIREMENTS .....</b>	<b>30</b>
4.1 Sample Containers, Preservation, and Holding Times (QAPP Worksheets #19 & 30). 30	
4.2 Field Quality Control Summary (QAPP Worksheet #20).....	31
4.3 Field SOPs/Methods (QAPP Worksheet #21) .....	32
4.4 Field Equipment Calibration, Maintenance, Testing, and Inspection Table (QAPP Worksheet #22).....	33
<b>5.0 ANALYTICAL REQUIREMENTS.....</b>	<b>35</b>
5.1 Analytical SOP's (QAPP Worksheet #23).....	35
5.2 Analytical Instrument Calibration (QAPP Worksheet #24).....	35
5.3 Analytical Instrument and Equipment Maintenance, Testing, and Inspection Table (QAPP Worksheet #25) .....	35
5.4 Sample Handling, Custody, and Disposal (QAPP Worksheets #26 & 27).....	35
5.5 Analytical QC and Corrective Action (QAPP Worksheet #28).....	35
<b>6.0 DATA MANAGEMENT AND DATA REVIEW .....</b>	<b>36</b>
6.1 Project Documents and Records Table (QAPP Worksheet #29).....	36
6.2 Assessments and Corrective Action (QAPP Worksheets #31, 32, & 33) .....	37
6.3 Data Verification and Validation Inputs (QAPP Worksheet #34) .....	41
6.4 Data Verification Procedures (QAPP Worksheet #35).....	43
6.5 Data Validation Procedures (QAPP Worksheet #36) .....	44
6.6 Data Usability Assessment (QAPP Worksheet #37).....	45
<b>7.0 REFERENCES .....</b>	<b>49</b>

## **LIST OF FIGURES**

Figure 1-1	Organizational Structure
Figure 2-1	Site Location Map
Figure 2-2	Prescribed Burn Air Monitoring Plan
Figure 2-3	Prescribed Burn Air Monitoring E-BAM Schedule

## **LIST OF TABLES**

Table 1	Burn Prescription (Example)
---------	-----------------------------

## **LIST OF ATTACHMENTS**

Attachment 1	QA Handbook for Air Pollution Measurement Systems, Volume II, Ambient Air Quality Monitoring Program
Attachment 2	E-BAM Operation Manual
Attachment 3	E-BAM Audit Checklist
Attachment 4	Additional Background Summary of the former Fort Ord Prescribed Burn Air Sampling and Analysis Program
Attachment 5	Response to Comments

## ABBREVIATIONS AND ACRONYMS

%	Percent
µg/m <sup>3</sup>	Micrograms per cubic meter
agl	above ground level
Army	United States Department of the Army
BCT	Base Cleanup Team
BLM	Bureau of Land Management
BRAC	Base Realignment and Closure
B.S	Bachelor of Science
CAP	Corrective Action Plan
CAR	Corrective Action Request
CERCLA	Comprehensive Environmental Response, Compensation, and Liability Act
CHMM	Certified Hazardous Material Manager
COPC	Chemical of Potential Concern
CQCSM	Contractor Quality Control Site Manager
CQM	Construction Quality Management
CPR	Cardiopulmonary Resuscitation
DDESB	Department of Defense Explosives Safety Board
DQCR	Daily Quality Control Report
DQO	Data Quality Objective
DTSC	Department of Toxic Substances Control
E-BAM	Environmental Proof Instrument Beta Attenuation Monitor
EDD	Electronic Data Deliverable
EM	Engineer Manual
EOD	Explosives Ordnance Disposal
EPA	United States Environmental Protection Agency
FTP	File Transfer Protocol
FWV	Fieldwork Variance
GIS	Geographic Information System
H&S	Health and Safety
HAZWOPER	Hazardous Waste Operations and Emergency Response
IDQTF	Intergovernmental Data Quality Task Force
KEMRON	KEMRON Environmental Services, Inc.
lpm	Liters per Minute
LUC	Land Use Control
MACTEC	MACTEC Engineering and Consulting, Inc.
MBARD	Monterey Bay Air Resources District
MEC	Munitions and Explosives of Concern
MMRP	Military Munitions Response Program
MR	Munitions Response
MRA	Munitions Response Area
MRS	Munitions Response Site

M.S	Master of Science
N/A	Not Applicable
NAAQS	National Ambient Air Quality Standard
PE	Professional Engineer
PM	Project Manager
POMFD	Presidio of Monterey Fire Department
QA	Quality Assurance
QAPP	Quality Assurance Project Plan
QC	Quality Control
RA	Remedial Action
RCA	Root Cause Analysis
RD/RA	Remedial Design/Remedial Action
REF	Reference
RI/FS	Remedial Investigation/Feasibility Study
ROD	Record of Decision
SAP	Sampling and Analysis Plan
SOP	Standard Operating Procedure
SUXOS	Senior Unexploded Ordnance Supervisor
TP	Technical Paper
UFP	Uniform Federal Policy
USACE	United States Army Corps of Engineers
USAF	United States Air Force
UXO	Unexploded Ordnance
UXOQCS	Unexploded Ordnance Quality Control Specialist
UXOSO	Unexploded Ordnance Safety Officer
WERS	Worldwide Environmental Remediation Services

## EXECUTIVE SUMMARY

The Uniform Federal Policy Quality Assurance Project Plans (UFP-QAPP) is a consensus quality systems prepared in support of the United States Army Corps of Engineers (USACE), Sacramento District, under the Worldwide Environmental Remediation Services (WERS) Contract, contract number W912DY-10-D-0027, Task Order CM01, for the continuation of the Comprehensive Environmental Response, Compensation, and Liability Act (CERCLA) Remedial Action (RA) at the former Fort Ord in accordance with the requirements of the *Uniform Federal Policy for Quality Assurance Project Plans* (UFP-QAPP Manual (Intergovernmental Data Quality Task Force [IDQTF], March 2005), *Optimized UFP-QAPP Worksheets* (IDQTF, March 2012), and the Interim Guidance Document 14-01, *Technical Guidance for Military Munitions Response Actions*, Engineer Manual (EM) 200-1-15 (USACE, October 2013). Prescribed burning is being conducted as part of the Munitions and Explosives of Concern (MEC) RA in accordance with the *Final Record of Decision (ROD)*, *Impact Area Munitions Response Area (MRA)*, *Track 3 Munitions Response Site (MRS)*, *Former Fort Ord, California* (United States Department of the Army [Army], 2008), and *Final Work Plan, Remedial Design/Remedial Action (RD/RA)*, *Track 3 Impact Area MRA, MEC Removal, Former Fort Ord, California* (USACE, 2009). Prescribed burns are identified as part of the remedial action proposed for Bureau of Land Management (BLM) Area B, as described in *Final, Revision 2, Track 2, Remedial Investigation/Feasibility Study (RI/FS) BLM Area B and MRS-16, Former Fort Ord, California* (Gilbane, 2015) and *Superfund Proposed Plan, RA is Proposed for BLM Area B MRS-16 Track 2 Munitions Response (MR) RI/FS, Former Fort Ord, California* (Army, 2015).

This Prescribed Burn Air Monitoring QAPP is based on the 28 optimized worksheets as described in the Optimized UFP-QAPP Worksheets and is intended to support the collection of appropriate air monitoring data during prescribed burns as part of the remedial actions. The included worksheets will serve as a guideline for project activities and data quality assessment. Worksheets deemed not applicable to this advanced geophysical classification-optimized QAPP format have been either modified to meet the intent of the worksheet or excluded. This Prescribed Burn Air Monitoring QAPP addresses the quality assurance (QA) and quality control (QC) elements of the American National Standards Institute - American Society of Quality E4-2004 and meets the requirements of the United States Environmental Protection Agency (EPA) QA/G-5 (EPA, 2002). This document is divided into the following seven sections:

- 1.0 Project Management
- 2.0 Project Quality Objectives
- 3.0 Sample Design
- 4.0 Sampling Requirements
- 5.0 Analytical Requirements
- 6.0 Data Management and Data Review
- 7.0 References

This Prescribed Burn Air Monitoring QAPP contains a series of worksheets that are for both general and specific information pertaining to the air sampling to be completed during prescribed burns in the Impact Area MRA and BLM Area B. The ROD for BLM Area B is currently pending signature.

This Prescribed Burn Air Monitoring QAPP describes the planning, implementation, acquisition, and assessment of data using effective methodologies and thorough QC activities that KEMRON Environmental Services (KEMRON), directed by the USACE, will use during prescribed burns at the former Fort Ord, California. This Prescribed Burn Air Monitoring QAPP also includes information for data management, data analysis and QC activities in support of the air sampling. This document is intended for use by field operators, supervisors, data managers and other technical experts responsible for implementing and coordinating field activities for the project.

**Crosswalk: UFP-QAPP to 2106-G-05**

Optimized UFP-QAPP Worksheets		2106-G-05 QAPP Guidance Section	
<b>Project Management</b>			
1 & 2	Title and Approval Page	2.2.1	Title, Version, and Approval/Sign-Off
3 & 5	Project Organization and QAPP Distribution	2.2.3	Distribution List
		2.2.4	Project Organization and Schedule
4, 7 & 8	Personnel Qualifications and Sign-off Sheet	2.2.1	Title, Version, and Approval/Sign-Off
		2.2.7	Special Training Requirements and Certification
6	Communication Pathways	2.2.4	Project Organization and Schedule
9	Project Planning Session Summary	2.2.5	Project Background, Overview, and Intended Use of Data
<b>Project Quality Objectives</b>			
10	Conceptual Site Model	2.2.5	Project Background, Overview, and Intended Use of Data
11	Project/Data Quality Objectives	2.2.6	Data/Project Quality Objectives and Measurement Performance Criteria
12	Measurement Performance Criteria	2.2.6	Data/Project Quality Objectives and Measurement Performance Criteria
13	Secondary Data Uses and Limitations	3	QAPP Elements for Evaluation Existing Data
14 & 16	Project Tasks & Schedule	2.2.4	Project Organization and Schedule
15	Project Action Limits and Laboratory-Specific Detection / Quantitation Limits	2.2.6	Data/Project Quality Objectives and Measurement Performance Criteria
<b>Sample Design</b>			
17	Sampling Design and Rationale	2.3.1	Sample Collection Procedure, Experimental Design, and Sampling Tasks
18	Sampling Locations and Methods	2.3.1	Sample Collection Procedure , Experimental Design, and Sampling Tasks
		2.3.2	Sampling Procedures and Requirements
<b>Sampling Requirements</b>			
19 & 30	Sample Containers, Preservation, and Hold Times	2.3.2	Sampling Procedures and Requirements
20	Field QC	2.3.5	Quality Control Requirements
21	Field Standard Operating Procedures (SOPs)	2.3.2	Sampling Procedures and Requirements
22	Field Equipment Calibration, Maintenance, Testing, and Inspection	2.3.6	Instrument/Equipment Testing, Calibration and Maintenance Requirements, Supplies and Consumables
<b>Analytical Requirements</b>			
23	Analytical SOPs (Not Applicable)	2.3.4	Analytical Methods Requirements and Task Description
24	Analytical Instrument Calibration	2.3.6	Instrument/Equipment Testing, Calibration and Maintenance Requirements, Supplies and Consumables



<b>Optimized UFP-QAPP Worksheets</b>		<b>2106-G-05 QAPP Guidance Section</b>	
25	Analytical Instrument and Equipment Maintenance, Testing, and Inspection	2.3.6	Instrument/Equipment Testing, Calibration and Maintenance Requirements, Supplies and Consumables
26 & 27	Sample Handling, Custody, and Disposal	2.3.3	Sample Handling, Custody Procedures, and Documentation
28	Analytical Quality Control and Corrective Action	2.3.5	Quality Control Requirements
<b>Data Management and Data Review</b>			
29	Project Documents and Records	2.2.8	Documentation and Records Requirements
31, 32 & 33	Assessments and Corrective Action	2.4	Assessments and Data Review (Check)
		2.5.5	Reports to Management
34	Data Verification and Validation Inputs	2.5.1	Data Verification and Validation Targets and Methods
35	Data Verification Procedures	2.5.1	Data Verification and Validation Targets and Methods
36	Data Validation Procedures (Not Applicable)	2.5.1	Data Verification and Validation Targets and Methods
37	Data Usability Assessment	2.5.2	Quantitative and Qualitative Evaluations of Usability
		2.5.3	Potential Limitations on Data Interpretation
		2.5.4	Reconciliation with Project Requirements

## 1.0 PROJECT MANAGEMENT

### 1.1 Title and Approval Page (QAPP Worksheets #1 & 2)

**Site Name:** Track 3 Impact Area Munitions Response Area and Track 2 BLM Area B  
**Site Location:** Former Fort Ord, California  
**Document Title:** Final, Quality Assurance Project Plan, Former Fort Ord, California,  
Volume II, Appendix C, Prescribed Burn Air Monitoring  
**Contract Number:** W912DY-10-D-0027

### Investigative Organization

#### AUTHOR SIGNATURE

Leland J.  
Meadows

Digitally signed by Leland  
J. Meadows  
Date: 2016.12.06 14:37:51  
-05'00'

Date: 12/06/16

Leland Meadows, CHMM  
KEMRON Project Chemist

#### REVIEW SIGNATURES

Erin K. Caruso

Digitally signed by Erin K. Caruso  
DN: C=US, E=ecarus@gilbaneco.com,  
O=Gilbane, OU=Federal Services, CN=Erin  
K. Caruso  
Reason: I am approving this document  
Date: 2016.12.06 11:46:06-08'00'

Date: 12/06/16

Erin Caruso, P.E., PMP  
Gilbane Deputy Project Manager

Maggie Sheatzley

Margaret Sheatzley  
KEMRON Technical Editor

Date: 12/06/16

Steve Crane

Digitally signed by Steve Crane  
DN: cn=Steve Crane, o=KEMRON,  
ou, email=scrane@kemron.com,  
c=US  
Date: 2016.12.06 14:36:17 -08'00'

Date: 12/06/16

Steve Crane, P.E., F. SAME  
KEMRON Project Manager

## Contracting Organization

EISEN.DAVID.E.123198  
5146

Digitally signed by EISEN.DAVID.E.1231985146  
DN: c=US, o=U.S. Government, ou=DoD, ou=PKI,  
ou=USA, cn=EISEN.DAVID.E.1231985146  
Date: 2016.12.06 13:23:18 -08'00'

Date: 12/06/16

David Eisen  
USACE Project Manager

MCNEILL.BENIT  
A.J.1403662670

Digitally signed by  
MCNEILL.BENIT.A.J.1403662670  
DN: c=US, o=U.S. Government, ou=DoD,  
ou=PKI, ou=USA,  
cn=MCNEILL.BENIT.A.J.1403662670  
Date: 2016.12.07 07:26:22 -08'00'

Date: 12/07/16

Bonnie McNeill  
USACE Chemist

**Plans and reports from previous investigations relevant to this project:**

<b>Title</b>	<b>Company</b>	<b>Date</b>
<i>Installation-Wide Multispecies Habitat Management Plan for Former Fort Ord, California (BW-1787)</i>	USACE	04/1997
<i>Final Track 3 Impact Area MRA MR RI/FS Report, Volumes 1 and 2 (OE-0596R)</i>	MACTEC Engineering and Environmental Services (MACTEC)	06/2007
<i>Final ROD, Impact Area MRA, Track 3 MRS, Former Fort Ord, California (OE-0647)</i>	Army	05/2008
<i>Final Work Plan, MRS-BLM Units 1-5 MEC Removal, Former Fort Ord, California includes MRS-BLM Units 1-5 Prescribed Burn Plan, Prescribed Burn Air Sampling and Analysis Plan (SAP), MRS-BLM Units 1-5 and Notification Plan, MRS-BLM Units 1-5 (OE-0626L)</i>	Shaw Environmental, Inc.	06/2008
<i>Final Prescribed Burn Air SAP, MRS-BLM Burn Units 11 and 12, Former Fort Ord, California (OE-0735H)</i>	MACTEC	08/2011
<i>Final (Revised) MRS-BLM Units 7 and 10 Prescribed Burn Plan (OE-0764C)</i>	Presidio of Monterey Fire Department (POMFD)	04/2013
<i>Final Prescribed Burn Air SAP, MRS-BLM Units 11 and 12 (OE-0851C)</i>	KEMRON	12/2015

## 1.2 Project Organization and QAPP Distribution (QAPP Worksheets #3 & 5)

Figure 1-1. Organizational Structure

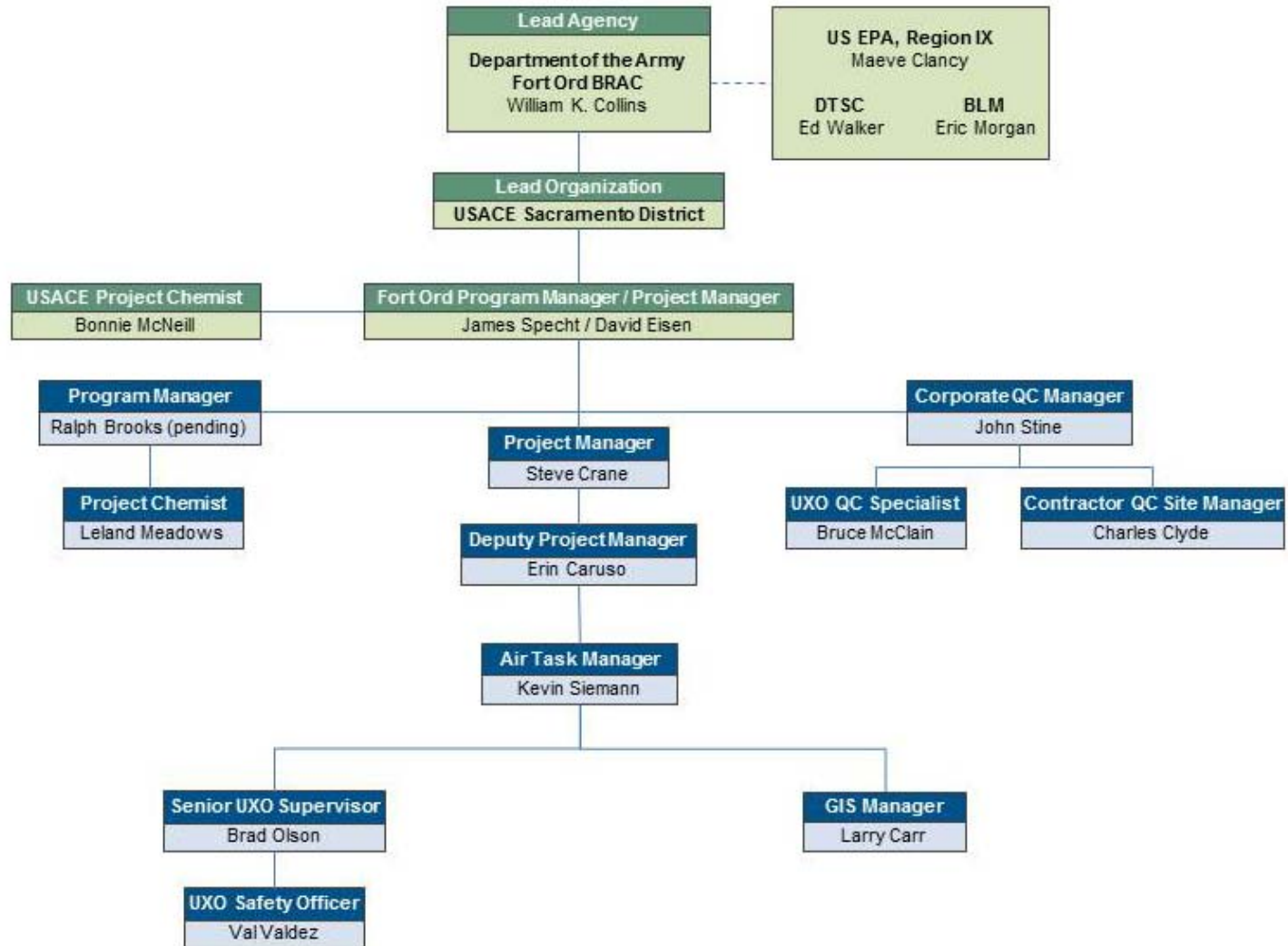

### 1.3 Personnel Qualifications and Sign-off Sheet (QAPP Worksheets #4, 7, & 8)

**ORGANIZATION: KEMRON**

Name	Project Title/Role	Education/Experience	Specialized Training/Certifications	Signature/Date
Ralph Brooks (Pending)	Program Manager			
John Stine	Corporate QC Manager	Senior Noncommissioned Officer Academy U.S. Navy Explosive Ordnance Disposal (EOD) School, Munitions Disposal Specialist U.S. Air Force (USAF) Munitions Maintenance Specialist Master EOD Technician Master EOD Training Instructor, USAF Department of Defense Explosives Safety Board (DDESB) Technical Paper (TP)-18- Qualified Senior Unexploded Ordnance Supervisor (SUXOS) 39 years of unexploded ordnance (UXO) and Military Munitions Response Program (MMRP) experience, with 32 years of supervisory experience	USACE UXO #0539 North Atlantic Treaty Organization QA/QC Evaluator/Inspector/Trainer QA/QC Officer, Unit Level, USAF QA/QC Manager, Air Combat Command, Major Command Manager EOD Headquarters USAF Munitions Specialist Training Naval Sea Systems Command Technical Instructors Course Hazardous Waste Operations and Emergency Response (HAZWOPER)	
Leland Meadows	Project Chemist	Bachelor of Science (B.S) Chemistry and Mathematics, Alabama A&M University, 2001 15 years' experience overseeing collection, analysis and data management of multi-media. 4 years analytical laboratory experience performing analysis of solids, drinking water, and wastewater 7 years as EPA Region IV Superfund Technical Assessment and Response Team member conducting multimedia monitoring and sampling, drafting and implementing QAPPs, data review and validation, and coordination of transportation and disposal.	Associate Safety Professional Certified Hazardous Materials Manager (CHMM)	

Steve Crane	Project Manager (PM)	Master of Science (M.S) Civil and Environmental Engineering 34 years of combined experience in environmental engineering, project management, program management, and business unit management Previous PM (2010-2014) for the \$60 million Fort Ord MEC Removal and Soil Remediation WERS task order for Gilbane	Registered Civil Engineer (Professional Engineer) [PE] {Arizona} USACE Architect - Engineer Contracting Short Course, USACE-Huntsville Program for Manager Development, Univ. of North Carolina – Chapel Hill Graduate Business School	
Bradley Olson	SUXOS	DDESB TP-18-Qualified SUXOS 30 years of EOD and UXO experience	Naval EOD School USACE Construction Quality Management (CQM) HAZWOPER HAZWOPER Supervisor 30-Hour Construction Safety 10-Hour Construction Safety	
Bruce McClain	Unexploded Ordnance Quality Control Specialist (UXOQCS)	DDESB TP-18-Qualified UXOQCS 30 years of EOD and UXO experience	Naval EOD School USACE CQM HAZWOPER HAZWOPER Supervisor 30-Hour Construction Safety 10-Hour Construction Safety	
Val Valdez	Unexploded Ordnance Safety Officer (UXOSO)	DDESB TP-18-Qualified UXOSO 25 years of EOD and UXO experience	Naval EOD School 30 Hour Construction Safety USACE CQM 1 <sup>st</sup> Aid/Cardiopulmonary Resuscitation (CPR) Radiation Safety HAZWOPER Supervisor	

**ORGANIZATION: Gilbane**

Name	Project Title/Role	Education/Experience	Specialized Training/Certifications	Signature/Date
Erin Caruso	Deputy PM (Gilbane PM)	M.S Engineering 14 years of MMRP experience Current Project Manager (2015-present) for the Fort Ord MEC Removal and Soil Remediation WERS task order for Gilbane	PE (California) USACE CQM Project Management Professional HAZWOPER	
Kevin Siemann	Air Task Manager	B.S Environmental Science 16 years of experience	HAZWOPER	

Name	Project Title/Role	Education/Experience	Specialized Training/Certifications	Signature/Date
Chuck Clyde	Contractor Quality Control System Manager (CQCSM)	17 years as QC Manager for various Department of Defense Projects	HAZWOPER 30-Hour Construction Safety CPR/First Aid American Petroleum Institute - 650/653 Storage Tank Management Confined Space Supervisor	
Larry Carr	Geographic Information System (GIS) Manager	B.S Geology 14 years of experience GIS (19 years overall experience in industry)	HAZWOPER	

Signatures indicate personnel have read and agree to implement this QAPP as written.



### 1.4 Communication Pathways (QAPP Worksheet #6)

<b>Communication Drivers</b>	<b>Organization</b>	<b>Name</b>	<b>Contact Information</b>	<b>Procedure (Timing, pathways, documentation, etc.)</b>
Regulatory agency interface	USACE	David Eisen	(831) 393-9692	USACE Fort Ord PM provides routine project updates to Base Realignment and Closure (BRAC) Cleanup Team (BCT) and stakeholders. Fieldwork variances (FWV) and notice of corrective action requests (CARs) will be forwarded within 7 business days of issuance of FWV and CARs.
Project status reports	KEMRON	Steve Crane	(831) 824-2321	KEMRON PM e-mails weekly status reports to USACE Fort Ord PM for distribution to Fort Ord project delivery team.
Stop work due to safety issues	KEMRON	Val Valdez	(831) 824-2309	UXOSO informs KEMRON PM and Health and Safety (H&S) Manager of critical safety issues and develops report. Ordnance and Explosives Safety Specialist and USACE Fort Ord PM informed of issue and receive report.
Point of Contact with USACE, Department of Toxic Substances Control (DTSC), EPA, Army BRAC, BLM	Gilbane Deputy PM	Erin Caruso	(925) 595-2337	All materials and information about the project will be forwarded to USACE and BRAC staff.
Point of Contact with USACE, Army BRAC, POMFD	Gilbane Air Task Manager	Kevin Siemann	(831) 824-2303	Consults with BRAC and POMFD to ensure that staff and contractors are available on burn days; coordinates field work with Project Chemist.
QC for analytical tasks	KEMRON	Leland Meadows	(404) 601-6949	Prepares QAPP and QAPP Amendments. Assures KEMRON compliance with WERS requirements
Field corrective actions	Gilbane	Chuck Clyde	(831) 824-2312	CQCSM prepares a Non-Conformance Report and, as applicable, a CAR and Corrective Action Plan (CAP). Forms are provided to the KEMRON Corporate QC Manager for review and approval. KEMRON Corporate QC Manager then provides forms to USACE Fort Ord PM for review and approval.

## **PROJECT MEETINGS**

Project meetings will be held on an as needed basis to discuss planning and scheduling, logistics and may include operational discussions as they relate to project decisions, deliverables, QC issues or concerns, corrective actions and data presentation to support decision making. The meeting attendees will be based on the topic(s) of discussion and may include subject matter experts. Prescribed burn air monitoring planning sessions will be documented in the monthly BCT meetings during burn season.

### **1.5 Project Planning Session Summary (QAPP Worksheet #9)**

Prescribed burn air monitoring planning sessions will be documented in the monthly BCT meetings during burn season. The BCT meeting minutes will contain a list of all participants, meeting agendas, description of discussions, and action items.

## 2.0 PROJECT QUALITY OBJECTIVES

### 2.1 Conceptual Site Model (QAPP Worksheet #10)

#### BACKGROUND INFORMATION

The former Fort Ord is adjacent to Monterey Bay in northwestern Monterey County, California, approximately 80 miles south of San Francisco (See [Figure 2-1](#)). The former Army post consists of approximately 28,000 acres adjacent to the cities of Seaside, Sand City, Monterey, and Del Rey Oaks to the south and Marina to the north. Laguna Seca Recreation Area and Toro Regional Park border the former Fort Ord to the south and southeast, respectively. Land use east of the former Fort Ord is primarily agricultural.

The military conducted munitions related activities (e.g., live-fire training) on the facility and as a result MEC may be present in parts of the former Fort Ord. The ROD (Army, 2008) for the Track 3 Impact Area Munitions Response Area (Impact Area MRA) addresses MEC that are known or suspected to be present in the Impact Area MRA. The Impact Area MRA (See [Figure 2-1](#)) is undeveloped, contains several rare, threatened and endangered species and is designated as a habitat reserve. The Impact Area MRA is part of the Fort Ord National Monument and will be managed by BLM once the remedial action is completed. The selected remedy includes vegetation clearance (including prescribed burning); technology-aided surface removal; digital geophysical surveys; subsurface MEC removal in selected areas; and land use controls (LUCs). Access to the Impact Area MRA is currently restricted to authorized personnel only. Remedial action activities have been ongoing in the Impact Area MRA since 2008.

The ROD for BLM Area B and MRS-16 is pending signature and will address MEC that may be present in the BLM Area B (See [Figure 2-1](#)). The BLM Area B is undeveloped, contains several rare, threatened and endangered species and is designated as a habitat reserve. BLM Area B is a part of the Fort Ord National Monument and is currently open to public recreation. A portion of BLM Area B has already been transferred to BLM and the remaining land will be transferred after all selected remedies are complete.

Prescribed burning is the primary method of vegetation clearance in habitat reserve areas (Impact Area MRA and BLM Area B) containing Central Maritime Chaparral. There is no regulatory requirement to perform air monitoring during prescribed burns, but the Army conducts monitoring as part of its former Fort Ord prescribed burn program (See [Attachment 4](#)). The monitoring locations on [Figure 2-1](#) are the monitoring locations for all Impact Area prescribed burns. Adjustments to the monitoring network will be considered for future prescribed burns within BLM Area B. The additional background summary of the former Fort Ord prescribed burn air sampling program in [Attachment 4](#) describes the 2003 air monitoring process for the Ranges 43-48 prescribed burn and refinements to the program over time. The monitoring program provides data to support the program objectives: 1) to assess the adequacy of the burn prescription relative to smoke dispersion and downwind impacts and 2) monitor and evaluate whether the prescribed burns at the former Fort Ord result in downwind ambient concentrations of particulate matter that

exceed the applicable health-based screening levels. The 24-hour National Ambient Air Quality Standard (NAAQS) for particulate matter less than 2.5 microns (PM<sub>2.5</sub>) of 35 micrograms per cubic meter ( $\mu\text{g}/\text{m}^3$ ) is used as the screening level.

Figure 2-1. Site Location

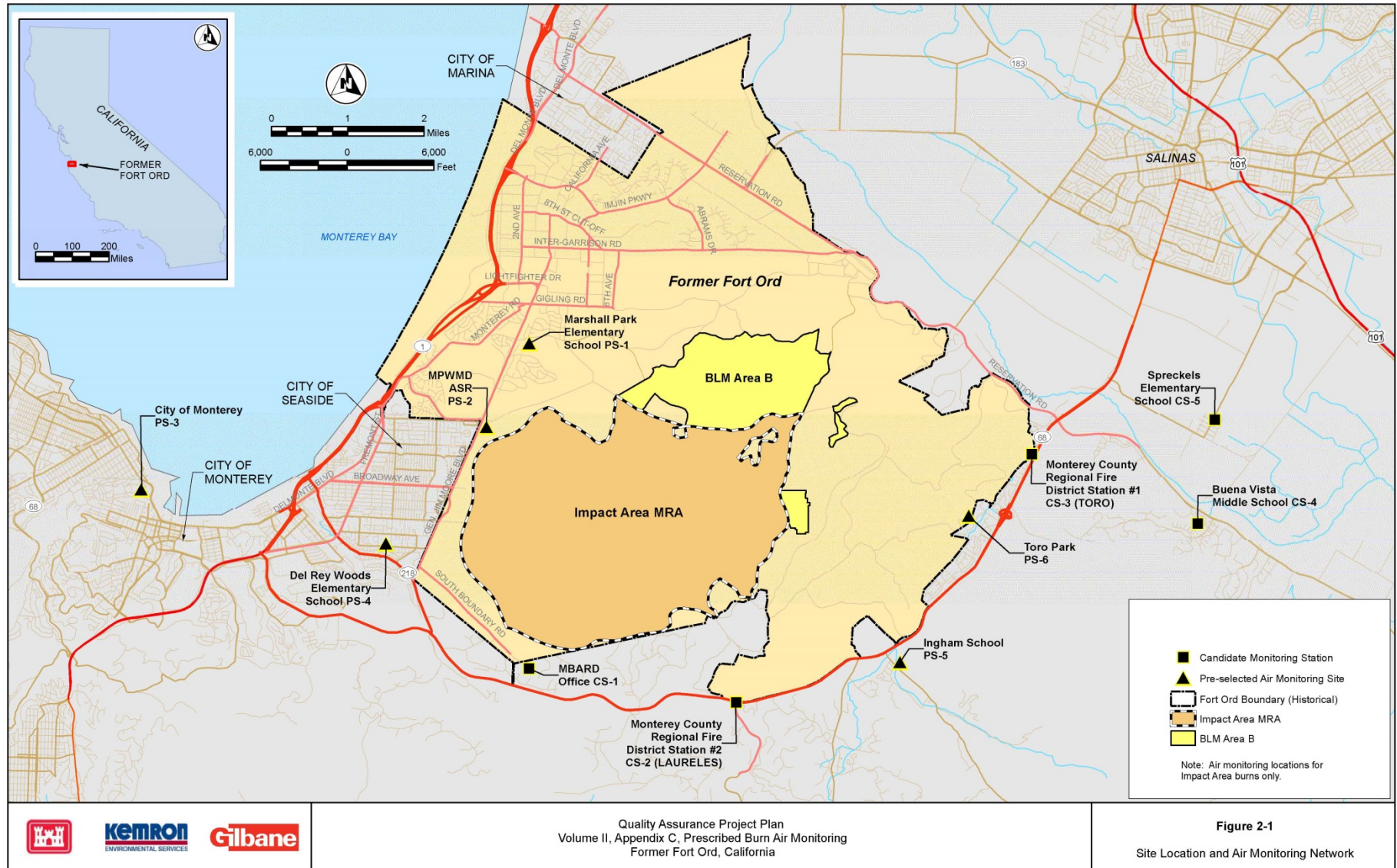

©\arcgis\SASAC\efort\_oh\PROJECTS\KEMRON\GAPP\_UFP\Map\_Docs\AirMonitoringNetwork\_UFP\_GAPP.mxd 5/16/2016 11:57 PM LCARR, Gilbane

## 2.2 Project Data Quality Objectives (QAPP Worksheet #11)

Data quality objectives (DQOs) have been developed based on the conceptual site model for potential smoke dispersion during prescribed burns. DQOs are qualitative and quantitative statements that outline the decision-making process. DQOs specify the level of uncertainty that will be accepted in results derived from data. The DQO process used for developing data quality criteria and performance specifications for decision making is consistent with the *Guidance on Systematic Planning Using the DQOs Process*, EPA QA/G-4 (EPA, 2006). The DQO process consists of the seven steps below.

- Step 1: State the problem
- Step 2: Identify the goal of the study
- Step 3: Identify information inputs
- Step 4: Define the boundaries of the study
- Step 5: Develop the analytical approach
- Step 6: Specify performance or acceptance criteria
- Step 7: Develop the plan for obtaining data

### Step 1: State the Problem

Prescribed burns will be used to clear vegetation from the surface of an area in order to facilitate removal of MEC from the Impact Area MRA and BLM Area B (See [Figure 2-1](#)). Combustion of vegetation has the potential to result in temporary smoke impacts to downwind receptors. The Environmental Proof Instrument Beta Attenuation Monitor (E-BAM) will be used to continuously measure PM<sub>2.5</sub> during prescribed burns. The recorded data will then be compared to the 24-hour based screening level.

Before 2011, the identity and quantity of emissions from prescribed burns at the former Fort Ord have been documented and particulate matter less than 10 microns (PM<sub>10</sub>) was identified as the most appropriate indicator of smoke. In 2011, the Army added sampling for PM<sub>2.5</sub> in coordination with agencies and the public. Prescribed burns will be conducted in stages and consist of small burns as shown on [Figure 2-2](#). Units on [Figure 2-2](#) that are blue are currently planned to be burned. Data to assess the adequacy of the burn prescription relative to smoke dispersion and downwind impacts needs to be collected; and the smoke from the combustion of vegetation needs to be evaluated for comparison to health-based screening levels. The particulate matter data will be compared to the screening level of the 24-hour NAAQS for PM<sub>2.5</sub>. To obtain data that can be compared to the 24-hour based screening level, until 2013 the Army's air monitoring program utilized a volumetric sampling method. The sample collection and analysis procedures meet the requirements established by the EPA for such measurements. Over time, the volumetric samplers required increasing levels of maintenance, and in 2015, the Army decided to replace the air monitoring equipment. Several units were evaluated, and the E-BAM



was selected as a rapid deployment sampler that can provide the desired data in a manner that is easy to deploy, requires less maintenance and can provide near-real time data.

### **Step 2: Identify the Goal of the Study**

For this evaluation, there are two principal questions:

- Is the burn prescription adequate?
- Do the prescribed burns at Fort Ord result in downwind ambient concentrations of PM<sub>2.5</sub> that exceed the health-based screening level?

The air monitoring results are one input into the burn planning efforts. The resultant alternative actions from the questions may recommend no change, recommend changes to the monitoring program, or recommend program evaluation of the prescribed burn for possible changes.

### **Step 3: Identify Information Inputs**

Inputs to decisions necessary for evaluating downwind impacts from prescribed burn activities at former Fort Ord are as follows:

- Identify target list of Chemicals of Potential Concern (COPCs): The Army has conducted air monitoring during past prescribed burns from 2003 until 2013 to evaluate several chemicals of potential concern which lead to the conclusion that air monitoring of particulate matter, PM<sub>2.5</sub>, is the best overall measure of smoke impact, addressing the regulatory agency and community suggestions, as well as providing greater data comparability between the Army and Monterey Bay Air Resources District (MBARD) (formerly Monterey Bay Unified Air Pollution Control District) programs. A background summary of the various COPCs that have been monitored historically and the rationale to monitor for PM<sub>2.5</sub> is presented in the background summary in [Attachment 4](#).
- Identify appropriate screening levels for COPCs (i.e., PM<sub>2.5</sub>) in air: Although the prescribed burns at the former Fort Ord would typically be conducted no more than one to three days per year, the most appropriate time scale for examining the potential significance of exposure to particulates in the smoke from prescribed burns at the former Fort Ord is acute exposure. For PM<sub>2.5</sub>, the current 24-hour federal standard of 35 µg/m<sup>3</sup> (98<sup>th</sup> percentile averaged over three years) was selected as the screening level for the project with the concurrence of the regulatory agencies. Therefore, the use of the current 24-hour based NAAQS for PM<sub>2.5</sub> as a screening level is considered very conservative.
- Measure downwind concentrations of COPCs in air during a prescribed burn event.
- Record field observations by visually identifying the downwind area that received smoke impacts.

#### **Step 4: Define the Boundaries of the Study**

Air monitoring will be conducted at pre-selected (fixed) and candidate locations with the E-BAMs. It is anticipated that the E-BAMs will be deployed and started within 24 hours of a burn mobilization decision or at a minimum 12 hours prior to burn ignition. Air monitoring data collected by the unit for comparison to applicable screening criterion will begin at burn ignition and continue for a 24-hour monitoring period. Monitoring units are placed in areas within or adjacent to populated areas that are likely to experience the presence of smoke. The sampling strategy is designed to characterize areas of maximum impact, areas prone to plume touch down during previous prescribed burns, and surround the former Fort Ord as the wind shifts through the day.

Baseline air monitoring was conducted prior to and after the prescribed burn at Ranges 43-48 in 2003. The  $PM_{10}$  was initially identified as a pollutant of interest and the best overall indicator of smoke dispersion and downwind impacts from the prescribed burns. Volumetric filter based air sampling for particulate matter was conducted from 2003 through the 2013 prescribed burns. In 2011, the Army transitioned the volumetric filter based air sampling from  $PM_{10}$  particle size to  $PM_{2.5}$  during prescribed burns in coordination and based on suggestions from the regulatory agencies and community. In 2015, the Army transitioned from the volumetric sampling method to E-BAMs. [Attachment 4](#) provides a detailed background and summary of the air monitoring program conducted at the former Fort Ord.

#### **Step 5: Develop the Analytical Approach**

To determine the concentration of  $PM_{2.5}$ , ambient air monitoring will be conducted with the E-BAM units. A 24-hour sampling interval from active ignition for each burn day will be conducted during the prescribed burn. The E-BAM internal data logger will provide 60-minute real time concentration averages of  $PM_{2.5}$ . The  $PM_{2.5}$  data collected by the E-BAM will be averaged hourly to normalize high or low individual data points collected during the continuous monitoring. The daily average will be computed by taking the 24-hour mean of the 24 hourly average data points starting with the time of ignition for comparison against the screening level. The decision rules identified for the program are as follows:

- If measured concentrations of  $PM_{2.5}$  in air during the 24-hour period are less than established screening level, then no modifications will be made to future prescribed burn operations.
- If measured concentrations of  $PM_{2.5}$  in air during the 24-hour period are greater than or equal to established screening level, then modifications to future prescribed burn operations will be evaluated.



## **Step 6: Specify Performance or Acceptance Criteria**

The null hypothesis is that, following this investigation, no modifications to future prescribed burn operations will be necessary ("future prescribed burn operations" in this context includes burn tactics for separate burns at later dates).

A decision error occurs when limitations in the available data lead the decision-maker to conclude that the baseline condition is false when it is true, or to conclude that the baseline condition is true when it is actually false. These two decision errors are termed false rejection error and false acceptance error, respectively.

A false positive decision error would be to conclude that modifications are necessary when, in fact, they are not. The consequence of this error would be that unnecessary modifications or limitations to future prescribed burn operations would be made, resulting in unnecessary cost to the government. A false negative decision error would be to conclude that modifications are not necessary when, in fact, they are. The consequence of this error would be that future prescribed burn operations could result in adverse impacts to human health.

This investigation employs a biased sampling strategy designed to characterize areas of maximum impact. Consequently, confidence limits on decision errors are not applicable to this investigation. Because the burn will occur under only prescribed conditions of wind direction and speed, the expected COPC distribution will not be random; i.e., the general area of smoke impact will be those areas located downwind under the prescribed conditions. Hence, the judgmental sampling strategy proposed here, and employed successfully on previous prescribed burns at the former Fort Ord, does not lend itself to statistically derived confidence levels for decision errors. The E-BAM technology limits the two contributors to decision error: sampling design error and measurement error.

### **Sampling Design Error**

This error is influenced by monitoring network design, the number of monitoring stations, and the interpretation/modeling of meteorological data. The following items were considered in order to minimize sampling design error:

- Ensure that the likely area of maximum impact is covered by air sampling monitors.
- Ensure that the data collection occurs during the 24-hour monitoring period that begins at ignition.
- Ensure that monitoring locations do not have other particulate matter sources that may compromise the use of the data.
- Ensure siting criteria for the particulate monitors meets the EPA and manufacturer specifications.
- Monitor changes in meteorological conditions.

## Measurement Error

This error is influenced by imperfections in the measurement and analysis system. The internal E-BAM data software will automatically run a self-test when power is applied. During data collection, deviations from the rolling average, high value excursions such as fault readings, and timeframes affected by power outages or other instrument errors will be logged within the system with a date, time, and type of error. Fault readings and system/instrument failures that are determined to have introduced bias to the concentration averages will be discarded from the data set by the Project Chemist. All data is analyzed in accordance with the methods governed by the QA/QC requirements documented in the SOPs listed in QAPP Worksheets #21. All samples will be collected and handled as specified in QAPP Worksheet #19. The QAPP Worksheet #12 presents the E-BAM Specifications which lists all of the equipment's capable parameters and specifications. The level of uncertainty in the data set will be considered acceptable if the E-BAM internal software passes all the self-tests performed during equipment start-up.

## Step 7: Develop the Plan for Obtaining Data

A single air monitoring network is derived with the adjustments needed from the previously approved air monitoring network in the *2015 Final Prescribed Burn Air SAP, MRS-BLM Units 11 and 12* (KEMRON, 2015). The sampling network consists of six, pre-selected (fixed) (noted as PS) locations and five candidate locations (noted as CS). See [Figure 2-1](#).

The air monitoring for all prescribed burns in units within the Impact Area MRA will be comprised of:

- The use of six, pre-selected (fixed) locations which are within or adjacent to populated areas that are likely to experience some smoke impacts.
- The use of one of the five candidate locations selected to address potential gaps in monitoring network coverage at the pre-selected (fixed) locations.

The candidate location provides a full network design capable of addressing potential gaps in the monitoring network coverage. Candidate locations have been identified to the south (CS-1 and CS-2) and to the northeast (CS-3 through CS-5) of units within the Impact Area MRA. The monitoring locations on [Figure 2-1](#) are the monitoring locations for all Impact Area MRA prescribed burns. Adjustments to the monitoring network will be considered for future prescribed burns within BLM Area B. For more information, see section 3.1 Sampling Locations and Methods.

The design focuses on obtaining data that describes PM<sub>2.5</sub> concentrations in air surrounding the prescribed burn units and near downwind populations. Another element of the optimization process is to consider and respond to, if necessary, the possibility that the location of the highest concentrations of COPCs in air may vary during the event as meteorological conditions evolve

throughout the day. This issue has been addressed by identifying and establishing the five candidate locations, from which one will be selected for each of the air monitoring events prior to the burn ignition. Additional background information is provided in Attachment 4.

The E-BAM internal data logger records raw data and produces real time averages based on default or user input settings. Real time averages are provided hourly by the E-BAM computer as a factory setting and are considered to be the most accurate real time average (settings vary from 1 min to 60 minutes for real time averages). The daily 24-hour average will be calculated by computing the mean of the E-BAM computer calculated one-hour averages. The E-BAM has internal software that automatically performs self-tests during start-up to assure the readings are within the tolerances in the manual provided in [Attachment 2](#).

The E-BAM raw and real time average data will be transmitted during the burn events via a data acquisition telemetry system producing a spreadsheet based output. The spreadsheet output will be uploaded to a file transfer protocol (FTP) site to be reviewed by the Project Chemist. The Project Chemist will perform data verification on the E-BAM raw data to ensure that quality control and quality assurance have been met when operating the E-BAM. See the E-BAM audit checklist in Attachment 3 for a complete list of power-up settings verifications and automatic self-tests.

### 2.3 Measurement Performance Criteria Table (QAPP Worksheet #12)

The E-BAM measures and records airborne PM<sub>2.5</sub> particulate concentration levels using the principle of beta ray attenuation. This method provides a simple determination of concentration in units of milligrams of particulate per cubic meter of air. A small <sup>14</sup>C (Carbon 14) element emits a constant source of high-energy electrons known as beta particles. These beta particles are detected and counted by a sensitive scintillation detector. A vacuum pump pulls a measured amount of dust-laden air through the filter tape, which is positioned between the source and the detector thereby causing an attenuation of the beta particle signal. The degree of attenuation of the beta particle signal is used to determine the mass concentration of particulate matter on the filter tape, and the volumetric concentration of particulate matter in ambient air. An in-depth scientific explanation of the theory of operation and the related equations is included in the back of the E-BAM Manual. Complete descriptions of the measurement cycles are found in Section 6 of the E-BAM manual.

As previously stated in Worksheet #11 Step 7, the QC and QA will be met by ensuring the proper field calibrations, pump test, flow checks and audits are performed at periodic intervals (*See Maintenance Item list on page 54 of the EBAM Manual*). This includes leak checks, nozzle/vane cleaning, ambient temperature and pressure sensor audits. Flow audits and calibrations will be performed using a traceable standard flow audit device. Span Membrane Test will also be conducted which consist of a 4 step zero and span calibration of the instrument, this test is pass/fail. Once all initial and preparatory phase inspections, calibrations, and testing are successfully completed the instrument is ready for service. During the follow-up phase any errors encountered during the set-up and operation of the E-BAM will be reviewed. All data points collected during a period in which the instrument falls out of normal operating parameters will be discarded. See [Attachment 3](#) to review the E-BAM audit checklist.

A list of parameters with their specification are provided for the E-BAM 9800 below. See Worksheet #37, Data Usability Assessment, to review the field duplicate analysis.

#### *E-BAM 9800 Specifications*

PARAMETER	SPECIFICATION*
<b>Measurement Principle:</b>	Particulate Concentration by Beta Attenuation.
<b>U.S. EPA Designations:</b>	Designed to meet Class III monitoring criteria. Not an EPA-designated FEM.
<b>Measurement Range:</b>	-0.005 to 65.530 µg/m <sup>3</sup> (-5 to 65,530 µg/m <sup>3</sup> ) 16 bit digital range.
<b>Accuracy:</b>	± 10% of indicated value for hourly measurements.
<b>Data Resolution:</b>	1 µg/m <sup>3</sup>
<b>Lower Detection Limit:†</b>	Less than 6.0 µg/m <sup>3</sup>

<b>(2σ, 1 hour measurement)</b>	
<b>Lower Detection Limit:† (2σ, 24 hour average)</b>	Less than 1.2 µg/m <sup>3</sup>
<b>Sample Time:</b>	Continuous air sampling with variable filter change periods.
<b>Measurement Cycles:</b>	Automatic hourly concentration measurements, with user selectable 1, 5, 10, 15, 30, or 60 minute quasi-real-time average output.
<b>Flow Rate:</b>	16.7 lpm. Adjustable up to 17.5 lpm. Actual or Standardized flow modes.
<b>Flow Accuracy:</b>	±2% of setpoint typical.
<b>Pump Type:</b>	Internal DC dual-diaphragm pump standard. 4000 hour rated
<b>Filter Tape:</b>	Continuous glass fiber filter, 30mm x 21m roll. Up to 1 year operation per roll.
<b>Span Check:</b>	Manual 800ug (typical) span foil included.
<b>Beta Source:</b>	14C (carbon-14), 60 µCi ±15 µCi (< 2.22 X 10 <sup>6</sup> Beq), Half-Life 5730 years.
<b>Beta Detector Type:</b>	Photomultiplier tube with patented scintillator assembly.
<b>Ambient Humidity Range:</b>	0 to 90% RH, non-condensing.
<b>Operating Temp. Range:</b>	-25 to +50°C intermittent. -25 to +40°C continuous.
<b>Humidity Control:</b>	Automatic 15 Watt inlet heater module.
<b>Approvals:</b>	CE, NRC, ISO-9001
<b>User Interface:</b>	Menu-driven interface with 4x20 character VFD display and dynamic keypad.
<b>Analog Voltage Output:</b>	0-1, 0-2.5, or 0-5 volt DC output equals 0-1000 µg/m <sup>3</sup> . Selectable to represent the hourly or real-time concentration.
<b>Serial Interface:</b>	RS-232 2-way serial port for PC, datalogger, or modem communications.
<b>Alarm Contact Closures:</b>	Normally closed contact closure relay output. 0.5A @ 100V DC max.
<b>Compatible Software:</b>	Comet™ (included), Air Plus™, terminal programs such as HyperTerminal®
<b>Error Reporting:</b>	Available through serial port, display, and relay output.
<b>Memory:</b>	4369 records (182 days @ 1 record/hr. 3 days @ 1 record/min).
<b>Power Supply:</b>	12 to 16 Volt DC input. 4.1 amps @12 VDC (50 Watts) max continuous draw.
<b>Weight:</b>	13.2 kg (29 lbs) E-BAM only. 23 kg (50 lbs) with tripod, PM10, 9250, power supply.
<b>Unit Dimensions:</b>	41 cm high x 36cm wide x 20cm deep. (16" x 14" x 8")

\*Specifications may be subject to change without notice (Every year specifications will be verified with the manufacturer, Met One Instruments, Inc.: (541) 471-7111, www.metone.com

† The hourly detection limit is defined as twice the standard deviation of the hourly zero noise of the instrument. The 24-hour detection limit is defined as the hourly detection limit divided by the square root of 24 (approx. 4.9).

**Acronyms:**

- µg/m<sup>3</sup> Micrograms per Cubic Meter of Air
- µCi Microcurie
- °C Degrees Celsius
- % Percent
- A Ampere
- cm centimeter
- DC Direct Current
- EPA Environmental Protection Agency
- FEM Federal Equivalent Method
- hr hour
- kg kilogram
- lbs pounds
- lpm liters per minute
- m meter
- min minute
- mm millimeter
- VDC Volts of Direct Current
- VFD Variable Frequency Drive

**2.4 Secondary Data Uses and Limitations Table (QAPP Worksheet #13)**

<b>Secondary Data</b>	<b>Data Source</b> (originating organization, report title, date and AR #)	<b>Data Generator(s)</b> (data types, data generation / collection dates)	<b>How Data Will Be Used</b>	<b>Limitations on Data Use</b>
Air	MACTEC (AMEC), Prescribed Burn Air Monitoring Report, MRS-BLM Burn Units 14 and 19, 2010 (OE-0712B)	PM <sub>10</sub> 2009	Data will be used to evaluate prescribed burn operations	N

Air	MACTEC (AMEC), Prescribed Burn Air Monitoring Report, MRS-BLM Burn Units 15 and 21, 2011 (OE-0732A)	PM <sub>10</sub> 2010	Data will be used to evaluate prescribed burn operations	N
Air	MACTEC (AMEC), Prescribed Burn Air Monitoring Report, MRS-BLM Burn Units 18 and 22, 2009 (OE-0689D)	PM <sub>10</sub> 2008	Data will be used to evaluate prescribed burn operations	N
Air	MACTEC (AMEC), Ranges 43-48, Prescribed Burn, Air Monitoring Report, 2004 (OE-0481J)	Aldehydes and acrolein; energetic materials and their likely breakdown products; PM <sub>10</sub> and total suspended particulates; particulate metals; and dioxins and furans 2002 -2003	Data will be used to evaluate prescribed burn operations	N
Air	KEMRON, interviews	Observations of sample collection personnel	Data will be used to evaluate prescribed burn operations	N
Air	Final, Prescribed Burn 2013, MRS-BLM Units 7 and 10, After-Action Report, Former Fort Ord, Monterey County, California (OE-0812B)	PM <sub>2.5</sub> 2013	The summary of prescribed burn operations 2013, sampling results and data analysis will be used as lessons learned.	N

## 2.5 Project Tasks and Schedule (QAPP Worksheets #14 and #16)

**Pre-Sampling Tasks:** There are two major pre-sampling tasks for the prescribed burn air monitoring and occur in June every year. See [Figure 2-3](#).

- Conduct E-BAM field calibrations.
- Conduct E-BAM flow checks as instructed in the E-BAM operation manual (Section 5 of [Attachment 2](#)) which audits and calibrates the flow system, ambient temperature sensor, barometric pressure sensors, filter sensors, analog output, and span membrane.
- Conduct verification with the E-BAM manufacturer will be made to ensure that no changes have been made to the specifications.
- Conduct a test run of remote data access.

**Sampling Tasks:** Sampling tasks will not commence until mobilization is confirmed. The POMFD will make the decision to mobilize for prescribed burn. Usually this decision is made about 48 hours prior to burn ignition. The air monitoring team will recommend the selection of one out of the five candidate locations for monitoring, and coordinate the selection with USACE. All the E-BAMs will be deployed at approved monitoring locations and undergo startup. The E-BAM data collection will start within 24 hours of a burn mobilization decision or at a minimum of 12 hours prior to burn ignition. The audit sheet (Section 13 of [Attachment 3](#)) will be completed during deployment at each monitoring station in the network. The 24 hours of collected data starting from burn ignition will be used to derive a 24-hour sample for comparison with the screening level. A telemetry system utilizing cell phone modems will transmit the data field to the third party data acquisition system as raw data may be used. The E-BAM raw data file will be near-time data and uploaded to the FTP. The following are the sampling task details:

- Concentration data and one-hour averages will be continuously logged throughout the burning process. The air monitoring during the burning process includes deploying and starting data collection at the six pre-selected and one candidate station upon a prescribed burn mobilization decision and collecting data during a 24-hour monitoring period beginning at ignition during the active burn events. Data will be recorded internally by the E-BAM and relayed for evaluation and interpretation via a telemetry system using cell phone modems. The data will be uploaded to a FTP site for download by the Project Chemist for data verification and validation.
- Air monitoring will be conducted at six pre-selected (fixed) locations and one of the five candidate locations for each burn event.
- All E-BAM monitors will collect data within the recommended siting criteria from approximately two (2) meters to 15 meters above ground level (agl), which is at or near



the adult human breathing zone and within the probe siting criteria recommended by the EPA ([Attachment 1](#)). EPA and Met One guidance for spacing from obstructions will also be followed, and the monitoring stations will be sited to avoid influence from nearby sources of particulate matter. Visual observations at the monitoring stations during the burn event will be recorded and used to identify whether any unexpected temporary or intermittent emission sources may have influenced the sample collection and reported concentrations.

**Analysis Tasks:** Data verification will be conducted by the Project Chemist utilizing the E-BAM reporting software, Comet. The internal E-BAM data software will automatically run a self-test when power is applied. During data collection, deviations from the rolling average, high value excursions such as fault readings, and timeframes affected by power outages or other instrument errors will be logged within the system with a date, time, and type of error. Fault readings and system/instrument failures that are determined to have introduced bias to the concentration averages will be discarded from the data set by the Project Chemist. In addition, the beta attenuation vacuum tube requires a one-hour warm up before accurate concentration data is being produced by the unit. Therefore, data from the first operational hour for each unit will be discarded as the manufacturer warns optimum accuracy is not achieved during the warm up of the vacuum tube. If any fault readings or system/instrument failures occur throughout the monitoring process, they will be removed from the data set.

**Quality Control Tasks:** The E-BAMs will be installed at monitoring locations and programmed in accordance with manufacturer recommendation specified in the Operation Manual included in [Attachment 2](#). Prior to deployment for an air monitoring event, each deployed E-BAM will undergo a series of field calibrations and flow checks as instructed in Section 5 of [Attachment 2](#), which audit and calibrate the flow system, ambient temperature sensor, barometric pressure sensors, filter sensors, analog output, and span membrane. The E-BAM audit sheet found in Section 13 of [Attachment 2](#) will be completed during deployment at each monitoring station in the network. The E-BAM set-up offers a series of prompts instructing the installer on the sequence to follow. Once the prompts are completed, the instrument will perform a series of self-test diagnostics and will alert the installer of any corrective action. Upon completion of set-up, the E-BAM will automatically place itself in normal operation mode. Particulate size selective concentration measurements will be made by using a specific PM<sub>2.5</sub> inlets.

The E-BAM is equipped for data logging in a data array in the internal E-BAM computer. Concentration data is recorded in hourly averages. After the initial set up and calibration and after burn ignition, sampling technicians will periodically check the E-BAM units to ensure the data is being collected and equipment errors are not occurring. Technicians will check the E-BAM units at least twice during the active ignition phase. During the E-BAM checks, the

E-BAM sampling screen readings displaying the latest hourly concentration data and flow rate will be recorded in the field log book.

Several methods exist to retrieve the data files from the E-BAM. The E-BAM is equipped with a two-way serial port which handles all digital data transfer, and can be directly connected to a computer, or can be used with an optional modem for remote communications through a phone line, cell system, radio link, or Internet Protocol addressable serial converter.

A telemetry system utilizing cell phone modems will transmit the data files to the third party data acquisition system as raw data may be used. The E-BAM raw data files will be uploaded to a FTP site where the Project Chemist will download the data files and perform data validation and verification. It is anticipated that the Project Chemist will download the data files at least twice during the active ignition phase to ensure data is being collected and data transmission is occurring. After active ignition, the E-BAM data will be downloaded periodically from the FTP site, at least twice during the remainder of the 24-hour monitoring period. Upon acquisition of the wireless cellular modems for the E-BAM units, the programming and interface with the third party data acquisition system will be field tested every year prior to burn season to ensure that during the burn data transmission failures do not occur. Met One Instruments will provide technical support as needed to verify that data transmission is seamless during the prescribed burns and verify all manufacturer specifications have not changed.

**Secondary Data:** See QAPP Worksheet #13.

**Data Management Tasks:** Data will be recorded internally by the E-BAM and relayed for evaluation and interpretation via a telemetry system using cell phone modems. The data will be uploaded to a FTP site for download by the Project Chemist. Data verification will be conducted by the Project Chemist utilizing the E-BAM reporting software, Comet.

**Documentation and Records:** All relevant field documentation, data and documentation will be maintained for at least five years. All final documents will be entered into the administrative record to be maintained longer than five years. Electronic copies including (but not limited to) all USACE Electronic Data Deliverables will be maintained in KEMRON's central repository for at least five years. The Air Task Manager, Project Chemist, and Data Manager will be responsible for ensuring that data are generated and managed in accordance with appropriate SOPs (See [Attachment 2](#)).

**Assessment/Audit Tasks:** The three-phase QC process will be implemented for the prescribed burn air monitoring activities. Each phase of QC is important for obtaining a quality product, however since the prescribed burn is anticipated to be a 24 to 48-hour event, the preparatory and initial inspections are most applicable to the scope of the project. Production work is not to be performed on a definable feature of work until successful preparatory and initial phase inspections have been completed. During these inspections, the Project or Air Task Manager will verify implementation of the requirements of the prescribed burn air sampling and analysis plan and QAPP.

**Data Review Tasks:** Data verification will be conducted by the Project Chemist utilizing the E-BAM reporting software, Comet. The internal E-BAM data software will automatically run a self-test when power is applied. During data collection, deviations from the rolling average, high value excursions such as fault readings, and timeframes affected by power outages or other instrument errors will be logged within the system with a date, time, and type of error. Fault readings and system/instrument failures that are determined to have introduced bias to the concentration averages will be discarded from the data set by the Project Chemist.

## 2.6 Project Action Limits and Laboratory-Specific Detection/Quantitation Limits (QAPP Worksheet #15)

Method	Analyte	CAS Number	Standard <sup>1</sup>	Lower Detection Limit: † (2σ, 1 hour measurement)	Lower Detection Limit: † (2σ, 24 hour average)	Measurement Range
N/A	PM <sub>2.5</sub>	N/A	35 µg/m <sup>3</sup> averaged for 24 hours	≤ 6.0 µg/m <sup>3</sup>	≤ 1.2 µg/m <sup>3</sup>	-0.005 to 65.530 mg/m <sup>3</sup> (- 5 to 65,530 µg/m <sup>3</sup> ) 16 bit digital range

<sup>1</sup>NAAQS for Air;

† The hourly detection limit is defined as twice the standard deviation of the hourly zero noise of the instrument. The 24-hour detection limit is defined as the hourly detection limit divided by the square root of 24 (approx. 4.9).

Note: Information taken from Attachment 2: E-BAM Operation Manual

### Acronyms:

µg/m<sup>3</sup> Micrograms per Cubic Meter of Air

CAS Chemical Abstracts Service

PM<sub>2.5</sub> Particulate matter less than 2.5 microns

### 3.0 SAMPLE DESIGN (QAPP Worksheet #17)

#### **Describe and provide a rationale for choosing the sampling approach:**

The POMFD, in conjunction with the stakeholders, will design the burns based on previous burns, the ability to contain the fire within the unit boundaries, and the ability to burn with minimal risk to the burn team. The burn prescription (See example at [Table 1](#)) will be reviewed and adjusted as needed based on the most recent environmental variables.

The air monitoring sampling network to be used during burn events will be comprised of six, pre-selected (fixed) locations and five candidate locations. See [Figure 2-1](#). To address potential gaps in the monitoring network, on the day before the planned prescribed burn, one of the five candidate locations will be selected for use based on the meteorological conditions anticipated for the burn day (next day). A recommendation and rationale for the selection will be provided to the Army. The candidate station selections are then provided to the EPA and DTSC, as well as MBARD, for their review. All E-BAM monitors will collect data within the recommended siting criteria from approximately two (2) meters to 15 meters agl, which is at or near the adult human breathing zone and within the probe siting criteria recommended by the EPA (Attachment 1). EPA and Met One guidance for spacing from obstructions will also be followed, and the monitoring stations will be sited to avoid influence from nearby sources of particulate matter. Visual observations at the monitoring stations during the burn event will be recorded and used to identify whether any unexpected temporary or intermittent emission sources may have influenced the sample collection and reported concentrations.

#### **Describe the sampling design and rationale in terms of what matrices will be sampled, what analytical groups will be analyzed and at what concentration levels, the sampling locations, the number of samples to be taken, and the sampling frequency:**

The monitoring program includes collecting PM<sub>2.5</sub> air monitoring data as follows:

- Concentration data and one-hour averages will be continuously logged throughout the monitoring period. The air monitoring during the burning process includes deploying and starting data collection upon a prescribed burn mobilization decision and collecting data during a 24-hour monitoring period beginning at ignition during the active burn events. Data will be recorded internally by the E-BAM and relayed for evaluation and interpretation via a telemetry system using cell phone modems. The data will be uploaded to a FTP site for download by the Project Chemist for data verification.
- Air monitoring will be conducted at six pre-selected (fixed) locations and one of the five candidate locations for each burn event.

The sampling locations for the air monitoring network are displayed on [Figure 2-1](#).

### 3.1 Sampling Locations and Methods (QAPP Worksheet #18)

The monitoring network will be comprised of six pre-selected (fixed) stations, supplemented by one additional candidate station which is aimed at collecting high quality data in areas surrounding the Impact Area and BLM Area B. To accommodate potential burn scenarios, the monitoring network locations will be chosen to meet the air monitoring units siting criteria, areas that may experience smoke and visual impacts based on typical, known weather patterns, and locations that ideally have AC power available. One of the five candidate locations will be selected on the day before the planned burn in consultation with the Army, EPA, DTSC and MBARD based on the meteorological conditions anticipated for the burn day (next day). The sampling network will provide adequate coverage to assess smoke impacts from one or more prescribed burns.

The pre-selected (fixed) and candidate locations for prescribed burns in the Impact Area MRAs are listed below.

Site ID	Location ID	Matrix	Sampling Frequency
PS-1	Marshall Park Elementary School	Air	Continuous
PS-2	Monterey Peninsula Water Management District Aquifer Storage and Recovery facility	Air	Continuous
PS-3	City of Monterey	Air	Continuous
PS-4	Del Rey Woods Elementary School	Air	Continuous
PS-5	Ingham School	Air	Continuous
PS-6	Toro Park	Air	Continuous
CS-1	MBARD Office	Air	Continuous
CS-2	Monterey County Regional Fire District Station #2, Laureles	Air	Continuous
CS-3	Monterey County Regional Fire District Station #2, Toro	Air	Continuous
CS-4	Buena Vista Middle School	Air	Continuous
CS-5	Spreckels Elementary School	Air	Continuous

Adjustments to the monitoring network will be considered for future prescribed burns in BLM Area B.

See Worksheet #37, Data Usability Assessment, to review the field duplicate analysis.

#### 4.0 SAMPLING REQUIREMENTS

##### 4.1 Sample Containers, Preservation, and Holding Times (QAPP Worksheets #19 & 30)

Sampling Device	Matrix	Analytical Group	Preparation/ Analytical Method	Container	Preservation	Maximum Holding Time
E-BAM	Air (filter media)	N/A	N/A	Simple, compact, and self-contained beta gauge	Steel Box	182 days (assuming 60 minute real time averages)

#### 4.2 Field Quality Control Summary (QAPP Worksheet #20)

<b>Matrix</b>	<b>Analytical Group</b>	<b>Preparation/ Analysis Reference</b>	<b>Approximate Number of Primary Sampling Locations</b>	<b>Number of Collocated Samples</b>	<b>Number of Field Blanks</b>	<b>Number of Matrix Spikes /Matrix Spike Duplicates</b>	<b>Number of Field Blanks</b>	<b>Approximate Total Number of Samples</b>
Air	N/A	N/A	7	0	N/A	N/A	0	7

For quality control purposes, all E-BAMs will meet all standards outlined in Table 12-1 in [Attachment 2](#). See [Attachment 3](#), E-BAM Audit Checklist, which will be used before starting to collect any sample data.

Data verification will be conducted by the Project Chemist utilizing the E-BAM reporting software, Comet. The internal E-BAM data software will automatically run a self-test when power is applied. During data collection, deviations from the rolling average, high value excursions such as fault readings, and timeframes affected by power outages or other instrument errors will be logged within the system with a date, time, and type of error. Fault readings and system/instrument failures that are determined to have introduced bias to the concentration averages will be discarded from the data set by the Project Chemist.

See Worksheet #37, Data Usability Assessment, to review the field duplicate analysis.



### 4.3 Field SOPs/Methods (QAPP Worksheet #21)

Reference Number	Document Control Reference Number	Title, Revision Date and/or Number	Originating Organization	Equipment Type	Specific for Project Work? (Y/N)
1	N/A	E-BAM-9800 Operation Manual Rev L	Met One Instruments, Inc.	E-BAM	N

<sup>1</sup> E-BAM-9800 Operation Manual with the SOPs is included as [Attachment 2](#).

#### 4.4 Field Equipment Calibration, Maintenance, Testing, and Inspection Table (QAPP Worksheet #22)

Field Equipment	Calibration Activity	Frequency	Acceptance Criteria	Corrective Action	Responsible Person
E-BAM	Leak Check <sup>1</sup> (Section 5.1 E-BAM Operation Manual)	Before any flow calibrations are performed, monthly, or whenever filter tape is changed.	The leak flow rate should drop below 1.0 lpm. If the leak value is greater than 1.0 lpm, then the nozzle and vane need cleaning, or there may be another leak somewhere in the system.	Resolve the leak (clean nozzle and vane will usually have a leak value of about 0.6 lpm or less)	Air Task Manager Sampling Technician
E-BAM	Nozzle and Vane Cleaning <sup>1</sup>	Regularly. The cleaning must be done at least each time the filter tape is changed; though monthly cleaning is highly recommended.	A clean result on the filter tape test (See photos in E-BAM Operational Manual).	Repeat the cleaning nozzle and vane protocol. Then rerun filter tape test.	Air Task Manager Sampling Technician
E-BAM	Ambient Temperature Sensor Audit <sup>1</sup> (Section 5.2 E-BAM Operation Manual)	Before any flow calibrations are performed	When E-BAM and reference (REF) parameters match	Investigate and try calibration again	Air Task Manager Sampling Technician
E-BAM	Ambient Barometric Pressure Sensor Audit <sup>1</sup> (Section 5.3 E-BAM Operation Manual)	Before any flow calibrations are performed	When E-BAM and REF parameters match	Investigate and try calibration again	Air Task Manager Sampling Technician
E-BAM	Flow Calibration <sup>1</sup> (Section 5.4 E-BAM Operation Manual)	Before Sampling	maintained within $\pm 0.2$ lpm	Investigate and try calibration again	Air Task Manager Sampling Technician

Field Equipment	Calibration Activity	Frequency	Acceptance Criteria	Corrective Action	Responsible Person
E-BAM	Filter RH Sensor Audit <sup>1</sup> (Section 5.5 E-BAM Operation Manual)	Before Sampling	±4 percent (%) default calibration	Investigate and run audit again	Air Task Manager Sampling Technician
E-BAM	Filter Temperature Sensor Audit <sup>1</sup> (Section 5.6 E-BAM Operation Manual)	Before Sampling	When E-BAM and REF parameters match	Investigate and try audit again	Air Task Manager Sampling Technician
E-BAM	Pump Tests (Section 5.7 E-BAM Operation Manual)	Before Sampling	E-BAM display is not higher than the “poor” value in the chart at that particular flow rate, then the E-BAM pump may need to be replaced.	Investigate and run test again	Air Task Manager Sampling Technician
E-BAM	Analog Output Audits <sup>1</sup> (Section 5.8 E-BAM Operation Manual)	Periodically checked to ensure data integrity	The actual voltage measured on the E-BAM analog output wires must match this setting within ±0.001 volts.	The analog output on the E-BAM will need to be adjusted	Air Task Manager Sampling Technician
E-BAM	Spane Membrane Tests <sup>1</sup> (Section 5.9 E-BAM Operation Manual)		Pass/Fail (If the measured and expected values are within 5%, the test will pass. If the values are outside of 5%, a failure will be generated)	If the test fails, the most common causes are a failing or dirty beta detector, or a dirty or damaged span membrane. Investigate, correct and run tests again.	Air Task Manager Sampling Technician

<sup>1</sup>SOPs are listed in the E-BAM Operational Manual and referenced on Worksheet #21.

## **5.0 ANALYTICAL REQUIREMENTS**

### **5.1 Analytical SOP's (QAPP Worksheet #23)**

Worksheet #23 is not applicable.

### **5.2 Analytical Instrument Calibration (QAPP Worksheet #24)**

Instrument calibrations are listed on Worksheet #22. See [Attachment 3](#), E-BAM Audit Checklist, which will be used before starting to collect any sample data.

### **5.3 Analytical Instrument and Equipment Maintenance, Testing, and Inspection Table (QAPP Worksheet #25)**

Equipment maintenance, testing and inspection table are listed on Worksheet #22. See [Attachment 3](#), E-BAM Audit Checklist, which will be used before starting to collect any sample data.

### **5.4 Sample Handling, Custody, and Disposal (QAPP Worksheets #26 & 27)**

The Sample Handling System is listed on the E-BAM Specification Table documented on Worksheet #12 and in [Attachment 2](#), E-BAM Operational Manual.

Data will be recorded internally by the E-BAM and relayed for evaluation and interpretation via a telemetry system using cell phone modems. The data will be uploaded to a FTP site for download by the Project Chemist for data verification.

### **5.5 Analytical QC and Corrective Action (QAPP Worksheet #28)**

See [Attachment 3](#), E-BAM Audit Checklist, which will be used before starting to collect any sample data.

## 6.0 DATA MANAGEMENT AND DATA REVIEW

### 6.1 Project Documents and Records Table (QAPP Worksheet #29)

<b>Sample Collection Documents and Records</b>	<b>On-site/Off-site</b>	<b>Analysis Documents and Records</b>
Pre-field activity operation checklist	On-site	Hardcopy in KEMRON Fort Ord office, in project file, or in designated storage facility. Electronic copies maintained on the main computer (server).
Field notes/logbook	On-site	Hardcopy in KEMRON Fort Ord, in project file, or in designated storage facility. Electronic copies maintained on the main computer (server).
Field envelopes and filter logs	On-site	Hardcopy in KEMRON Fort Ord office, in project file, or in designated storage facility. Electronic copies maintained on the main computer (server).
Field calibration logs	On-site	Hardcopy in KEMRON Fort Ord office, in project file, or in designated storage facility. Electronic copies maintained on the main computer (server).
Audit/assessment checklists/reports	On-site	Hardcopy in KEMRON Fort Ord office, in project file, or in designated storage facility. Electronic copies (if present) maintained on the main computer (server).
Corrective action forms and/or field change requests	On-site	Hardcopy in KEMRON Fort Ord office, in project file, or in designated storage facility. Electronic copies (if present) maintained on the main computer (server).
Raw Data	On-site	Hardcopy in KEMRON Fort Ord office, in project file, or in designated storage facility. Raw data file will be provided to MBARD which has an ability to make the data available on its website for public information.
Validated data	On-site	Hardcopy in KEMRON Fort Ord office, in project file, or in designated storage facility which will be downloaded from the FTP site. Electronic copies (if present) maintained on the main computer (server).
Air Monitoring Report	On-site	Hardcopy in KEMRON Fort Ord office, in project file, or in designated storage facility. Electronic copies (if present) maintained on the main computer (server).
Three Phase QC Forms	On-site	Hardcopy in KEMRON Fort Ord office, in project file, or in designated storage facility. Electronic copies (if present) maintained on the main computer (server).

## **6.2 Assessments and Corrective Action (QAPP Worksheets #31, 32, & 33)**

This worksheet documents procedures for performing testing, inspections and quality control for all field equipment and procedures. This worksheet is used to document responsibilities for conducting project assessments, responding to assessment findings and implementing corrective actions. Appropriately scheduled assessments allow management to implement corrective actions in a timely manner, thereby correcting non-conformances and minimizing their impact on DQOs/Project Quality Objective. Where appropriate the failure response will prescribe a corrective action. Otherwise, a root cause analysis (RCA) and CAR are required.

### **THREE PHASES OF CONTROL**

The CQCSM is responsible for verifying compliance with this portion of the QAPP through implementation of a three-phase control process, which ensures that project activities comply with the approved plans and procedures. The specific QC monitoring requirements are discussed below. This section specifies the minimum requirements that must be met and to what extent QC monitoring must be conducted and documented by the CQCSM.

The CQCSM will ensure that the three-phase QC process is implemented for each air sampling event. Each phase is considered relevant for obtaining necessary product quality. However, the preparatory and initial inspections are particularly invaluable in preventing problems. Work will not be performed until the preparatory and initial phase inspections have been completed and any non-conformance issues have been resolved.

#### **Preparatory Phase Inspection**

The Preparatory Phase comprises the planning and design process leading up to the actual field activities. The CQCSM will perform a Preparatory Phase inspection before beginning each air sampling event. The purposes of this inspection is to review applicable specifications and plans to verify that the necessary resources, conditions, and controls are in place and compliant before work activities start. Upon completion of the inspection, the CQCSM will complete a generic Preparatory Phase Inspection Checklist.

To perform the inspection, the CQCSM will review the appropriate sections of the QAPP and site-specific air monitoring plan. The CQCSM will verify that required plans and procedures have been approved and are available to the field staff; field equipment is appropriate, available, functional, and properly tested for its intended/stated use; staff responsibilities have been assigned and communicated; the staff members have the necessary knowledge, expertise, and information to perform their jobs; arrangements for support services have been made; training in accordance with the requirements of this QAPP and site-specific air monitoring plan has occurred; and the prerequisite mobilization tasks have been completed.

Project personnel must correct or resolve discrepancies between existing conditions and the approved QAPP and site-specific air monitoring plan identified by the CQCSM during the Preparatory Phase inspection. The CQCSM will verify that unsatisfactory and/or nonconforming conditions have been corrected before beginning work.

### **Initial Phase Inspection**

The Initial Phase occurs at the startup of field activities associated with a specific air sampling event. At the onset of a particular air sampling event, the CQCSM will perform an Initial Phase inspection and complete a generic Initial Phase Inspection Checklist. The main objectives of the inspection are to check preliminary work for compliance with procedures and specifications, establish an acceptable level of workmanship, check for omissions, and resolve differences of interpretation. During the Initial Phase inspection, the CQCSM will ensure that discrepancies between site practices and approved plans or specifications are identified and resolved. The resolution of discrepancies is a critical step in the Initial Phase inspection. The Initial Phase inspection will also verify that the Accident Prevention Plan/Site Safety and Health Plan adequately identifies all hazards associated with actual field conditions and verifies that appropriate safe work practices are being followed. The inspection results will be documented by the CQCSM in the form of daily reports. Should results of the inspection be unsatisfactory, the Initial Phase will be rescheduled and performed again.

### **Follow-up Phase Inspection**

Completion of the Initial Phase QC inspection leads directly into the Follow-up Phase, which covers the routine day-to-day activities at the site. The CQCSM will perform a Follow-up Phase inspection at regular intervals while a particular air sampling event is performed. This inspection ensures continuous compliance and verifies an acceptable level of workmanship. To conduct and document these inspections, the CQCSM will complete a generic Follow-up Phase Inspection. The CQCSM will monitor onsite practices and operations taking place and verify continued compliance with the specifications and requirements detailed in this Prescribed Burn Air Sampling QAPP and site-specific air monitoring plan. Discrepancies between site practices and approved plans/procedures will be resolved, and corrective action for unsatisfactory and nonconforming conditions or practices will be resolved by the CQCSM before continuing work.

### **Deficiency Identification and Resolution**

While deficiency identification and resolution occurs primarily at the operational level, QC audits provide a backup mechanism to address problems that either are not identified or cannot be resolved at the operational level. Deficiencies identified by the CQCSM are to be corrected by operational staff and documented.

### **Corrective Action**

A CAR can be issued by any member of an operation, including subcontractor employees. The CAR is then forwarded to CQCSM who is then responsible for evaluating the validity of the request. The CQCSM will then work with the appropriate individuals to conduct a RCA (if necessary) and then develop a CAP (if necessary) that includes assigning personnel and resources, and specifying and enforcing a schedule for corrective actions. The prescribed corrective action is then documented on the CAR, including who the corrective action was completed by and, who verified that the corrective action was completed. Once a corrective action has been completed, the CAR and supporting information/documentation will be forwarded to the Corporate QC Manager for closure.

The recommendations provided in the CARs and corrective actions implemented on the project will be reviewed during Follow-Up QC inspections. The purposes of this CAR review are to ensure that established protocols are implemented properly; verify that corrective actions have been implemented; ensure that corrective actions are effective in resolving problems; identify trends within and among similar work units; and facilitate system RCAs of potential larger systemic problems.

### **Corrective Action Request Tracking**

Each CAR will be given a unique identification number and tracked until corrective actions have been implemented and verified by the CQCSM prior to closure of the CAR.

### **QC Inspection Points**

Data verification will be conducted by the Project Chemist utilizing the E-BAM reporting software, Comet. The internal E-BAM data software will automatically run a self-test when power is applied. During data collection, deviations from the rolling average, high value excursions such as fault readings, and timeframes affected by power outages or other instrument errors will be logged within the system with a date, time, and type of error. Fault readings and system/instrument failures that are determined to have introduced bias to the concentration averages will be discarded from the data set by the Project Chemist.

Specific QC inspection points are listed below for each air sampling event of the project. These points outline the QC procedure and corrective action criteria. This QC function is an integral part of each task and will be managed by the CQCSM, who will work with the field managers to measure project and quality objectives. See table below.



<b>Assessment Type</b>	<b>Frequency</b>	<b>Internal or External</b>	<b>Organization Performing Assessment</b>	<b>Person(s) Responsible for Performing Assessment (Title)</b>	<b>Person(s) Responsible for Responding to Assessment Findings (Title)</b>	<b>Person(s) Responsible for Identifying and Implementing Corrective Actions (CA) (Title)</b>	<b>Person(s) Responsible for Monitoring Effectiveness of CA (Title)</b>
Project-Specific QAPP	Once	Internal	KEMRON	Project Chemist	Air Task Manager	PM	QC Manager
Project-Specific QAPP	Once	External	USACE	USACE Chemist	Air Task Manager	KEMRON PM	USACE PM
Field Preparedness	At beginning of field work	Internal	KEMRON	CQCSM	Air Task Manager	PM	Project Chemist
Air Sampling Data Review	Per sampling event	Internal	KEMRON	CQCSM	Air Task Manager	PM	Project Chemist
Air Data Verification	Per sampling event	Internal	KEMRON	PM	Air Task Manager	CQCSM	Project Chemist
H&S Review	As Needed	Internal	KEMRON	PM	Air Task Manager	CQCSM	Project Chemist
Daily Quality Control Report (DQCR)	Daily during sampling event	Internal	KEMRON	PM	Air Task Manager	CQCSM	Program Chemist

### 6.3 Data Verification and Validation Inputs (QAPP Worksheet #34)

This worksheet lists the inputs that will be used during data verification and validation. Inputs include planning documents, field records, and geophysical analysis records. Data verification is a check that all specified activities involved in collecting and analyzing samples/data have been completed and documented and that the necessary records (objective evidence) are available to proceed to data validation. Data validation is the evaluation of conformance to stated requirements, including those in the contract, methods, SOPs and the UFP-QAPP.

<b>Verification Input</b>	<b>Description</b>	<b>Internal/ External</b>	<b>Responsible for Verification (Name, Organization)</b>
Audit reports	Upon report completion, a copy of all audit reports will be placed in the project file. If corrective actions are required, a copy of the documented corrective action taken will be attached to the appropriate audit report in the project file. At the completion of the site work, project file audit reports will be reviewed internally to ensure that all appropriate corrective actions have been taken and that corrective action reports are attached. If corrective actions have not been taken, the PM will be notified to ensure action is taken.	I	KEMRON PM (Steve Crane)
Field notes	Field notes will be reviewed internally, at intervals as needed during the project, and at the completion of the work, and placed in the project file. A copy of the field notes will be attached to the final report.	I	Air Task Manager (Kevin Siemann, Gilbane) PM (Steve Crane, KEMRON)
Sampling locations, number of samples	Verify that sample locations and quantities will be sufficient to satisfy DQOs.	I	Field Staff (Various) Air Task Manager (Kevin Siemann, Gilbane) Project Chemist (Leland Meadows, KEMRON)
Electronic Data Deliverable (EDD)	The EDD will be reviewed to ensure that they comply with the format and are complete.	I	Project Chemist (Leland Meadows, KEMRON)

The three phase QC inspection method described in Worksheets 31, 32, and 33 will be used by the CQCSM to assess and document project quality. Data verification procedures that are to be used by the CQCSM are listed in WS #35. Data validation procedures that are to be used by the CQCSM are listed in WS #36.

#### 6.4 Data Verification Procedures (QAPP Worksheet #35)

This worksheet documents procedures that will be used to verify project data. It applies to both field and digital data. Data verification is a completeness check to confirm that all required activities were conducted, all specified records are present, and the contents of the records are complete.

Step IIa/IIb	Validation Input	Description	Responsible for Validation (Name, Organization)
IIa	Methods	Records support implementation of the SOP	Air Task Manager (Kevin Siemann, Gilbane)
IIa	Performance requirements	Verify that SOPs are sufficient to satisfy DQOs.	Project Chemist (Leland Meadows, KEMRON)
IIa	Sampling locations, number of samples	Verify that sample locations and quantities will be sufficient to satisfy DQOs.	Project Chemist (Leland Meadows, KEMRON)
IIa	DQCR and other field documentation	Review daily E-BAM activity reports, including pertinent field equipment data for errors.	Project Chemist (Leland Meadows, KEMRON)
IIb	Deviations	Determine impacts of any deviations from specified methods.	Project Chemist (Leland Meadows, KEMRON)
IIb	Sensitivity	Verify that sensitivity is achieved as outlined in the QAPP.	Air Task Manager (Kevin Siemann, Gilbane)
IIb	Precision	Review data against performance criteria and determine the impact of any results out of criteria.	Project Chemist (Leland Meadows, KEMRON)
IIb	Accuracy	Review data against performance criteria and determine the impact of any results out of criteria.	Project Chemist (Leland Meadows, KEMRON)
IIb	Field change requests	Review any change request or corrective action documentation. Determine the impact to project objectives.	Air Task Manager (Kevin Siemann, Gilbane)
IIb	EDDs	Verify that EDDs are acceptable.	Air Task Manager (Kevin Siemann, Gilbane)
IIb	Data summary	Summarize data quality in final report.	Project Chemist (Leland Meadows, KEMRON)

Notes:

Step IIa assesses and documents compliance with the laboratory methods and procedures, project work plans, and contract requirements.

Step IIb assesses and documents compliance with the QC in the QAPP.

### **6.5 Data Validation Procedures (QAPP Worksheet #36)**

Worksheet #36 is not applicable.

## 6.6 Data Usability Assessment (QAPP Worksheet #37)

This worksheet documents procedures that will be used to perform the data usability assessment and involves a qualitative and quantitative evaluation of the collected data to determine if the project data are of the right type, quality, and quantity to support the decisions that need to be made. It involves a retrospective review of the systematic planning process to evaluate whether underlying assumptions are supported, sources of uncertainty have been managed appropriately, data are representative of the population of interest, and the results can be used as intended, with the acceptable level of confidence.

### **Summarize the usability assessment process and all procedures, including interim steps and any statistics, equations, and computer algorithms that will be used:**

The outputs from the verification and validation process will be used to determine usability.

#### **Field Certification**

Data review, verification, and validation will be conducted by the Project Chemist utilizing the E-BAM reporting software, Comet.

#### **Laboratory Data Quality Indicators: Sensitivity, Precision, Accuracy, Representativeness, Comparability and Completeness**

The internal E-BAM data software will automatically run a self-test when power is applied. During data collection, deviations from the rolling average, high value excursions such as fault readings, and timeframes affected by power outages or other instrument errors will be logged within the system with a date, time, and type of error. Fault readings and system/instrument failures that are determined to have introduced bias to the concentration averages will be discarded from the data set by the Project Chemist.

#### **Sensitivity**

Sensitivity is an absolute quantity, the smallest absolute amount of change that can be detected by a measurement. The lower detection limit will be evaluated by the project team prior to sample analysis. The Project Action Limits and Laboratory-Specific Detection/Quantitation Limits (QAPP Worksheet #15) presents the lower detection limit for E-BAM used to support the project decision limits.

**Precision:**

Precision describes the reproducibility of the measurement. Precision is defined as the degree of mutual agreement between individual measurements of the same property under similar conditions and provides a measurement of the reproducibility of an analytical result. Precision will be evaluated by running two E-BAMs simultaneously in the same location during a 24-hour test run prior to the first prescribed burn. It will be considered a precision failure by using the performance measurement criteria to ensure the “found” data of a parameter is within the “expected” value on the two E-BAMs.

If precision failure occurs the Project Chemist will work with the Air Task Manager, field equipment technicians, and the E-BAM manufacturer to resolve the precision failure. Once the believed resolution is implemented another test run and field calibration will commence. Troubleshooting of the E-BAMs will continue until precision is achieved.

If any precision failures occur during the test run the results will be documented in the Air Monitoring Report.

**Accuracy:**

Accuracy is the degree of agreement between an analytical measurement and a reference accepted as a true value. The accuracy of a measurement system can be affected by errors introduced by field contamination, equipment handling, equipment preparation, or sampling techniques. Measurement will be collected for flow rate and the timing device of the monitor and compared to acceptance criteria. The E-BAM specifications is on worksheet #12 presents the acceptable accuracy for the E-BAM during this investigation. Accuracy will be evaluated through the E-BAM audit checklist analysis at each E-BAM. Every E-BAM will undergo a series of tests to complete the E-BAM audit sheet (See [Attachment 3](#)) and will document the expected and found data sets. Accuracy failure occurs when the “found” data of a parameter does not meet the “expected” value. The “expected” value must meet the parameter specification outlined on the measurement performance criteria table in WS#12. The Project Chemist will work with the Air Task Manager, field equipment technicians, and the E-BAM manufacturer to determine the cause of any poor accuracy.

If the accuracy is detected poor during calibration, the rationale for limitations on the dataset will be documented. The impact of any trends in accuracy/bias identified in the dataset also will be discussed in the Air Monitoring Report. The impacted data will be qualified as described in the data validation templates presented in [Attachment 2](#).

**Representativeness:**

Representativeness expresses the degree to which sample data accurately and precisely represent the characteristics of a population, variations in a parameter at a sampling point, or an environmental condition that they are intended to represent. For this project, representative data will be obtained through careful selection of sampling locations and analytical parameters. Representative data also will be obtained through proper collection and handling of equipment to avoid interference. Representativeness of data also will be ensured through consistent application of the appropriate established field procedures.

Equipment procedures will be reviewed to verify that SOPs were followed and method requirements were met during the analysis of project samples. Equipment sample storage practices will be assessed for potential impacts on the representativeness of the data. The site-sampling layout, including sampling locations, frequency of sampling, and timing of sampling activities, will be reviewed by the stakeholders. Any limitations on the dataset due to representativeness will be discussed in the Air Monitoring Report.

**Completeness:**

Completeness is a measure of the percentage of verified project-specific data. Verified data are obtained when the Project Chemist reviews the E-BAM data during data collection. If there are fault readings and system/instrument failures that are determined to have introduced bias to the concentration averages they will be discarded from the data set by the Project Chemist. E-BAM monitoring data will be analyzed in accordance with the procedures outlined in this QAPP and Site-Specific Air Monitoring Plan and documented in the Air Monitoring Plan.

When data verification is completed, the percent completeness value will be calculated by dividing the number of acceptable hourly sample results by the total number of hours planned for this investigation. The percent of completeness will be documented in the Air Monitoring Report.

**Comparability:**

Comparability expresses the confidence with which one data set can be compared with another. Comparability of data will be achieved by consistently following standard field procedures outlined in SOPs and published methods. In addition, a standard unit of measurement will be used in reporting analytical and field data. Analytical and field methods selected for this investigation are consistent with the methods used during previous investigations of this type. Oversight by experienced team members ensure that the procedures are conducted in a manner to meet the project objectives. Any deviation from field methods will be documented on a change request form. The project team



will review the change request to determine if the change will impact the comparability of the data. Any impacts which result in limitations of the data will be discussed in the Air Monitoring Report.

**Describe the evaluative procedures used to assess overall measurement error associated with the project:**

The verification and validation processes described in Worksheets 35 through 36 present the information that will be used to assess the overall measurement error to determine if the project objectives have been met and that the data are useable.

**Identify the personnel responsible for performing the usability assessment:**

The entire project team is responsible for assessing whether the data meet the project objectives. Personnel at all levels will generate data and documentation that will be reviewed to identify trends, relationships, and/or anomalies in the dataset.

**Describe the documentation that will be generated during usability assessment and how usability assessment results will be presented so that they identify trends, relationships (correlations), and anomalies:**

Field personnel will generate field forms, maps, and notes describing the daily procedures. A DQCR will be generated during sampling and data acquisition and will discuss any successes and/or deviations from the Work Plan.

The Air Task Manager will review the documentation on a daily basis to identify any anomalies or trends that may be occurring. An Air Monitoring Report will be generated for the air sampling data for usability assessment and will discuss the successes and failures of the work done to control the quality and meet the project objectives. Any systemic problems and/or individual anomalies will be discussed and related to the project objectives.

## 7.0 REFERENCES

Gilbane, 2015. *Final, Revision 2, Track 2 Munitions Response Remedial Investigation /Feasibility Study, BLM Area B and MRS-16, Former Fort Ord, California*. May. (OE-0802D)

Intergovernmental Data Quality Task Force (IDQTF), 2012. *Uniform Federal Policy for Quality Assurance Project Plans, Part 2a (Revised): Optimized UFP-QAPP Worksheets*. March.

KEMRON Environmental Services, Inc. (KEMRON), 2015. *Final Prescribed Burn Air Sampling and Analysis Plan, MRS-BLM Units 11 and 12, Former Fort Ord, California*. December. (AR# OE-0851C)

United States Army Corps of Engineers (USACE), 2009. *Final Work Plan, Remedial Design (RD)/Remedial Action (RA), Track 3 Impact Area Munitions Response Area (MRA), Munitions and Explosives of Concern Removal, Former Fort Ord, California*. August. (AR# OE-0660K)

\_\_\_\_\_, 2013. *Engineering Manual 200-1-15, Technical Guidance for Military Munitions Response Actions, Environmental and Munitions Center of Expertise Interim Guidance Document (IGD) 14-01*. October.

United States Department of the Army (Army) 2008. *Final Record of Decision, Impact Area Munitions Response Area, Track 3 Munitions Response Site, Former Fort Ord, California*. May. (AR# OE-0647)

\_\_\_\_\_, 2015. *Superfund Proposed Plan for BLM Area B and Munitions Response Site 16 Track 2 Munitions Response Remedial Investigation/Feasibility Study, Former Fort Ord, California*. April. (AR# OE-0846)

United States Environmental Protection Agency (EPA), 2002. *Guidance for Quality Assurance Project Plans, EPA QA/G-5*. December.

United States Environmental Protection Agency (EPA), 2006. *Guidance on Systematic Planning Using the Data Quality Objectives Process, EPA QA/G-4*. February.

## TABLES

**Table 1 - Burn Prescription**  
 Quality Assurance Project Plan  
 Former Fort Ord, California

**Burn Prescription Matrix:**

Fuel model chosen is from the Standard Fire Behavior Fuel Model 2005.

FUEL MODEL:	Shrub 8	
Environmental Variables:	<b>HOT</b>	<b>COLD</b>
Relative Humidity %	20	80
Wind Speed (mph)	8	0
Temperature (F) (Dry Bulb %)	90°	45°
Live Fuel Moisture %	60	100
Dead Fuel Moisture % 1hr. T/L	5	12
10hr. T/L	6	10
100hr. T/L	8	11
Soil / Duff Moisture %	50	50
Probability of Ignition	66%	28%
Season	<b>Summer</b>	<b>Winter</b>

Burn Prescription Matrix: from Final MRS-BLM Units 11 and 12 Prescribed Burn Plan, August 2011, Updated May 2015.

Note: Burn prescription is site-specific; this table is an example.

## FIGURES



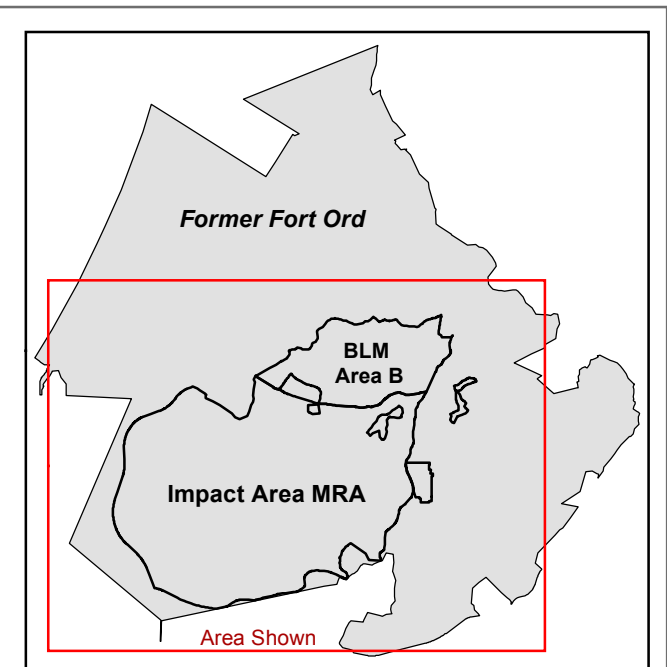
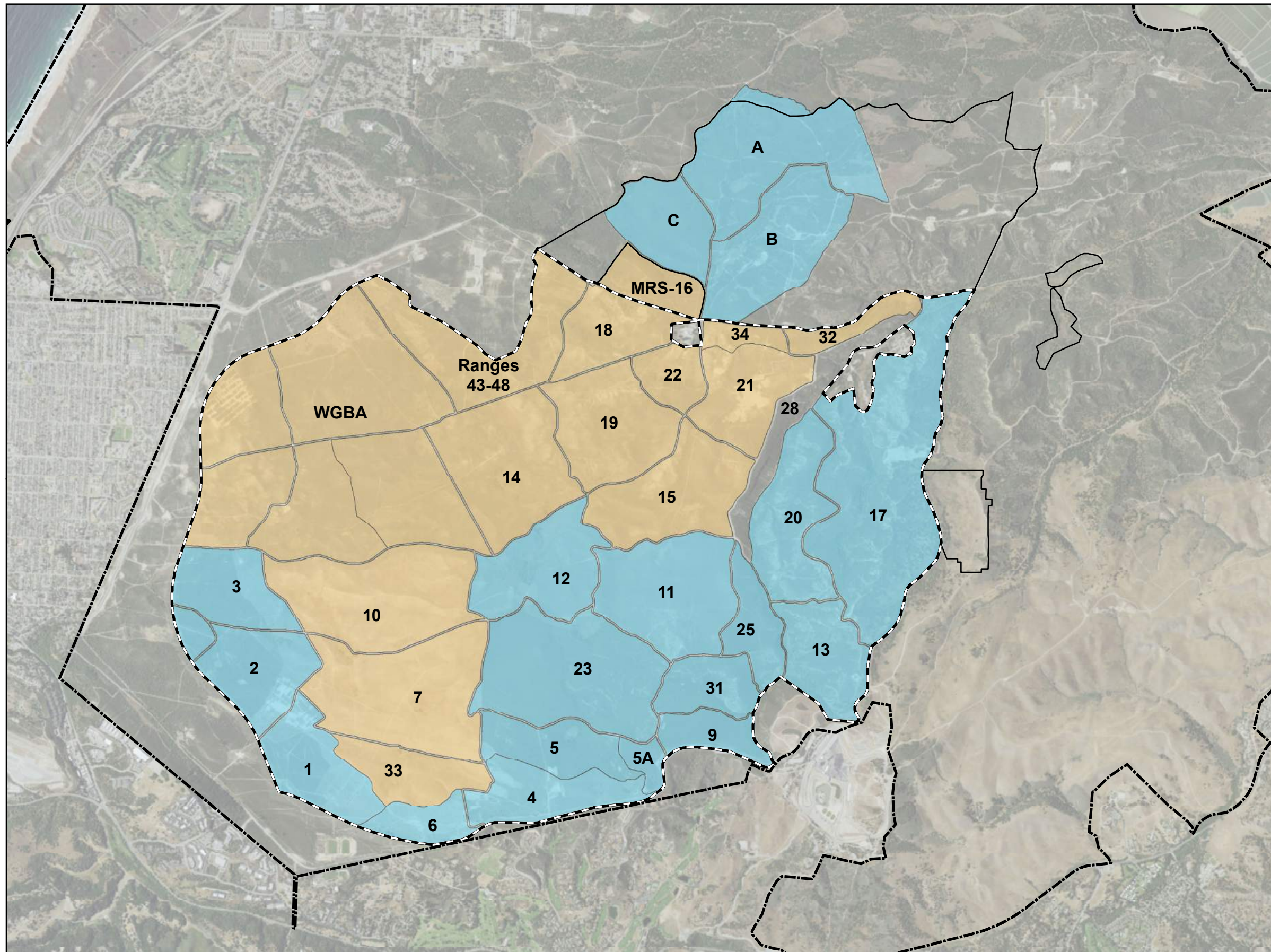

- Burn Complete
- Planned Burn
- Impact Area
- BLM Area
- Fort Ord Boundary (Historical)



Quality Assurance Project Plan  
 Volume II, Appendix C, Prescribed Burn Air Monitoring  
 Former Fort Ord, California

**Figure 2-2**  
 Prescribed Burn Area Monitoring Plan



Figure 2-3. Prescribed Burn Air Monitoring E-BAM Schedule

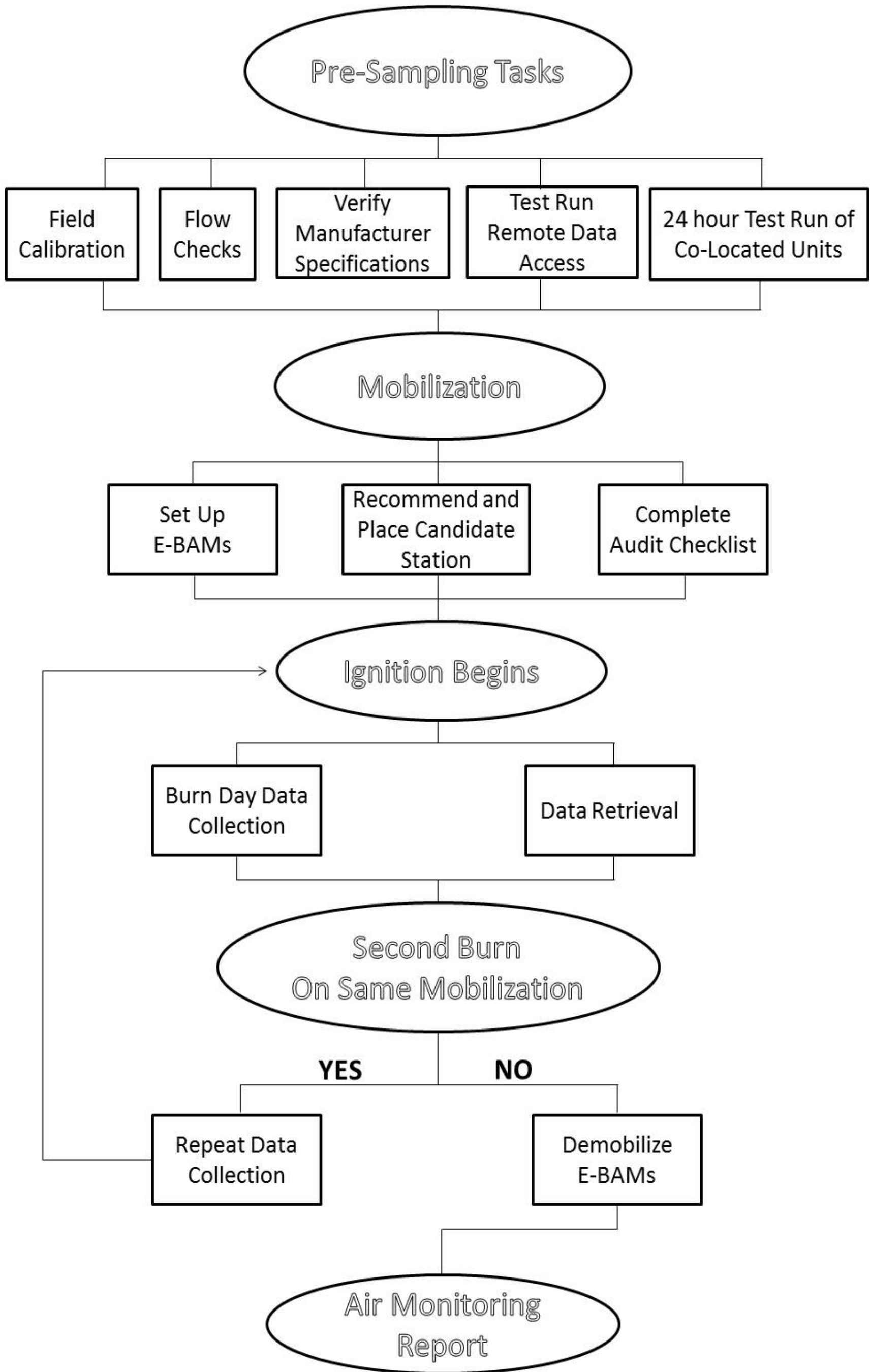

ATTACHMENT 1  
QA HANDBOOK FOR AIR POLLUTION MEASUREMENT SYSTEMS, VOLUME II,  
AMBIENT AIR QUALITY MONITORING PROGRAM





# **Quality Assurance Handbook for Air Pollution Measurement Systems**

## **Volume II**

### **Ambient Air Quality Monitoring Program**

**QA Handbook for Air Pollution Measurement Systems**

**Volume II**

**Ambient Air Quality Monitoring Program**

U.S. Environmental Protection Agency  
Office of Air Quality Planning and Standards  
Air Quality Assessment Division  
RTP, NC 27711

## *Contents*

<b>Section</b>	<b>Page</b>	<b>Revision</b>	<b>Date</b>
Contents	iv	1	12/08
Figures	vi	1	12/08
Tables	vii	1	
Acknowledgments	viii	1	12/08
Acronyms and Abbreviations	ix	1	12/08
<b>0. Introduction</b>		1	12/08
0.1 Intent of the Handbook	1/2		
0.2 Use of Terms Shall, Must, Should, May	2/2		
0.3 Use of Footnotes	2/2		
0.4 Handbook Review and Distribution	2/2		
<b>PROJECT MANAGEMENT</b>			
<b>1. Program Background</b>		1	12/08
1.1 Ambient Air Quality Monitoring Network	1/10		
1.2 The EPA Quality System Requirements	5/10		
1.3 The Ambient Air Monitoring Program Quality System	7/10		
<b>2. Program Organization</b>		1	12/08
2.1 Organization Responsibilities	1/7		
2.2 Lines of Communication	5/7		
2.3 Quality Assurance Workgroups	7/7		
<b>3. Data Quality Objectives</b>		1	12/08
3.1 The DQO Process	4/7		
3.2 Ambient Air Quality DQOs	5/7		
3.2 Measurement Quality Objectives	5/7		
<b>4. Personnel Qualification and Training</b>		1	12/08
4.1 Personnel Qualifications	1/3		
4.2 Training	2/3		
<b>5. Documentation and Records</b>		1	12/08
5.1 Management and Organization	2/8		
5.2 Site Information	2/8		
5.3 Environmental Data Operations	3/8		
5.4 Raw Data	7/8		
5.5 Data Reporting	7/8		
5.6 Data Management	8/8		
5.7 Quality Assurance	8/8		
<b>MEASUREMENT ACQUISITION</b>			
<b>6. Monitoring Network Design</b>		1	12/08
6.1 Monitoring Objectives and Spatial Scales	4/14		
6.2 Monitoring Site Location	7/14		
6.3 Monitor Placement	11/14		
6.4 Minimum Network Requirements	11/14		
6.5 Operating Schedules	12/14		
<b>7. Sampling Methods</b>		1	12/8
7.1 Environmental Control	1/14		
7.2 Sampling Probes and Manifolds	4/14		
7.3 Reference/Equivalent and Approved Regional Methods	10/14		
<b>8. Sample Handling and Custody</b>		1	12/08
8.1 Sample Handling	2/6		
8.2 Chain of Custody	4/6		
<b>9. Analytical Methods</b>		1	12/08
9.1 Good Laboratory Practices	2/2		
9.2 Laboratory Activities	2/2		

<i>Section</i>	<i>Page</i>	<i>Revision</i>	<i>Date</i>
<b>10. Quality Control</b>		1	12/08
10.1 QC Activity Areas	3/8		
10.2 Internal vs. External Quality Control	4/8		
10.3 CFR Related Quality Control Samples	7/8		
10.4 Use of Computers for Quality Control	8/8		
<b>11. Instrument/Equipment Testing, Inspection, and Maintenance</b>		1	12/08
11.1 Instrumentation	1/6		
11.2 Preventative Maintenance	4/6		
<b>12. Calibration</b>		1	12/08
12.1 Calibration Standards and Reagents	2/11		
12.2 Multi-point Verifications/Calibrations	7/11		
12.3 Frequency of Calibration and Analyzer Adjustment	8/11		
12.4 Adjustment to Analyzers	9/11		
12.5 Data Reduction using Calibration Information	10/11		
12.6 Validation of Ambient Data	11/11		
<b>13 Inspection/Acceptance for Supplies and Consumables</b>		1	12/08
13.1 Supplies Management	1/4		
13.2 Standards and Reagents	2/4		
13.3 Volumetric Glassware	2/4		
13.4 Sample Containers	3/4		
13.5 Particulate Sampling Filters	3/4		
13.6 Field Supplies	4/4		
<b>14. Data Acquisition and Management</b>		1	12/08
14.1 Data Acquisition	2/14		
14.2 Data Transfer-Public Reporting	9/14		
14.3 Data Transfer-Reporting to External Data Bases	11/14		
14.4 Data Management	13/14		
<b>ASSESSMENT/OVERSIGHT</b>			
<b>15. Assessment and Corrective Action</b>		1	12/08
15.1 Network Reviews	1/14		
15.2 Performance Evaluations	4/14		
15.3 Technical Systems Audits	8/14		
15.4 Data Quality Assessments	14/14		
<b>16. Reports to Management</b>		1	12/08
16.1 Guidelines for Preparation of Reports to Management	2/4		
<b>DATA VALIDATION AND USABILITY</b>			
<b>17. Data Review, Verification, Validation</b>		1	12/08
17.1 Data Review Methods	3/7		
17.2 Data Verification Methods	3/7		
17.3 Data Validation Methods	4/7		
<b>18. Reconciliation with Data Quality Objectives</b>		1	12/08
18.1 Five Steps of the DQA Process	1/9		
<b>APPENDICES</b>			
A. National Monitoring Program Fact Sheets	11	1	12/08
B: Ambient Air Monitoring QA Information and Web Addresses	4		
C: Using the Graded Approach for the Development of QMPs and QAPPs	6		
D: Measurement Quality Objectives and Validation Templates	25		
E: Characteristics of Spatial Scales Related to Each Pollutant	7		
F: Sample Manifold Design for Precursor Gas Monitoring	13		
G: Example Procedure for Calibrating Data Acquisition System	3		
H: Audit Information	46		
I: Example of Reports to Management	25		

## *Figures*

<i>Number</i>	<i>Title</i>	<i>Section/Page</i>
1.1	Ambient air quality monitoring process	1/1
1.2	Hierarchy of quality system development	1/5
1.3	Ambient Air Quality Monitoring QA Program	1/7
2.1	Program organization and lines of communication	2/1
2.2	Relationship of monitored pollutants to site, monitoring organizations and primary quality assurance organizations	2/4
3.1	Effect of positive bias on the annual average estimate resulting in a false rejection error	3/1
3.2	Effect of negative bias on the annual average estimate resulting in a false acceptance error	3/1
6.1	Wind rose pattern	6/8
6.2	Sampling schedule based on ratio to the 24-hour PM <sub>10</sub> NAAQS	6/13
7.1	Example design for shelter	7/2
7.2	Position of calibration line in sampling manifold	7/5
7.3	Acceptable areas for PM <sub>10</sub> and PM <sub>2.5</sub> micro, middle, neighborhood, and urban samplers except for microscale canyon sites	7/7
7.4	Optical mounting platform	7/8
8.1	Example sample label	8/3
8.2	Example field COC form	8/6
8.3	Example laboratory COC form	8/6
10.1	QC samples for PM <sub>2.5</sub> placed at various stages of measurement process	10/2
10.2	Example control chart	10/8
12.1	Suggested zero/span drift limits	12/8
14.1	DAS data flow	14/4
14.2	Flow of data from gas analyzers to final reporting	14/4
15.1	Definition of independent assessment	15/7
15.2	Pre-Audit activities	15/8
15.3	On-Site audit activities	15/10
15.4	Audit finding form	15/11
15.5	Post-audit activities	15/12
15.6	Audit response form	15/13
18.1	DQA in the context of data life cycle	18/2

## *Tables*

<i>Number</i>	<i>Title</i>	<i>Section/Page</i>
3-1	Measurement Quality Objectives Developed into a Validation Template	3/7
4-1	Monitoring Functions the Need Some Level of Staffing or Expertise	4/1
4-2	Suggested Sequence of Core QA Related Ambient Air Training Courses ...	4/3
5-1	Types of Information the Should be Retained Through Document Control	5/1
6-1	Relationship Among Monitoring Objectives and Scale of Representativeness	6/5
6-2	Summary of Spatial Scales for SLAMS, NCore, PAMS, and Open Path Sites	6/6
6-3	Relationships of Topography, Air Flow, and Monitoring Site Selection	6/9
6-4	Site Descriptions of PAMS Monitoring Sites	6/10
6-5	Monitoring Station Categories Related to Monitoring Site Placement	6/11
6-6	Completeness Goals for Ambient Monitoring Data	6/14
7-1	Environment Control Parameters	7/3
7-2	Summary of Probe and Monitoring Path Siting Criteria	7/6
7-3	Minimum Separation Distance between Road and Sampling Probes...	7/7
7-4	Techniques for Quality Control for Support Services	7/10
7-5	Performance Specifications for Automated Methods	7/12
9-1	Acceptable Analytical Methods	9/1
10-1	QC Samples Used in Various Ambient Air Monitoring Programs	10/5
10-2	PM <sub>2.5</sub> Field and Lab QC Checks	10/6
10-3	Ambient Air Monitoring Measurement Quality Samples	10/7
11-1	Routine Operation Checks	11/5
12-1	Certification Periods for Compressed Gas Calibration Standards...	12/4
12-2	Instrumentation and Devices Requiring Calibration and Certifications	12/6
14-1	AQS Data Reporting Requirements	14/12
14-2	NCore Information Technology Performance Needs	14/13
15-1	National Performance Evaluation Activities Performed by EPA	15/5
15-2	NPAP Acceptance Criteria	15/7
15-3	Suggested Elements of an Audit Plan	15/9
16-1	Types of QA Reports to Management	16/2
16-2	Sources of Information for Preparing Reports to Management	16/2
16-3	Presentation Methods for Use in Reports to Management	16/3
18-1	Summary of Violations of DQO Assumptions	18/5
18-2	Weights for Estimating Three-Year Bias and Precision	18/6
18-3	Summary of Bias and Precision	18/8

## ***Acknowledgments***

This QA Hand Book is the product of the combined efforts of the EPA Office of Air Quality Planning and Standards, the EPA Regional Offices, and the State, Tribal and Local monitoring organizations. The development and review of the material found in this document was accomplished through the activities of the QA Strategy Workgroup. The following individuals are acknowledged for their contributions.

### **State, Tribal and Local Organizations**

Andy Clifton, Andy Johnson, Anna Kelley, Arun Roychowdhury, Barb Regynski, Ben Davis, Charles Pearson, Ceresa Stewart, Cindy Wike, Dick Duker, Dennis Fenlon, Don Gourley, Donovan Rafferty, Edward Huck, Erick Saganic, Glenn Gehring, Hugh Tom, Jim Conner, Joseph Ugorowski, Jackie Waynick, James Jordan, Jeff Wasson, Jeremy Hardin, Jason Low, Keith Duncan, Ken Cowen, Kent Curtis, Kevin Watts, Leonard Marine, Larry Taylor, Leroy Williams, Merrin Wright, Mary Kay Clark, Melinda Ronca-Battista, Melvin Schuchardt, Mickey Palmer, Mike Draper, Mike Hamdan, Nydia Burdick, Patti DeLaCruz, Paul Sanborn, Robert Franicevich, Rachael Townsend, Randy Dillard, Rayna Broadway, Richard Heffern, Ritchie Scott, Robert Olson, Ryan Callison, Scott Reynolds, Stephanie McCarthy, Susan Kilmer, Susan Selby, Tyler Muxworthy, Terry Rowles, Thomas Mcgrath, Sandra Wardwell, Yousaf Hameed

### **EPA Regions**

#### Region

- 1 Mary Jane Cuzzupe, Peter Kahn, Chris St.Germane, Karen Way
- 2 Mustafa Mustafa, Avraham Teitz, Mark Winter
- 3 Victor Guide, Andrew Hass
- 4 Greg Noah, Danny France, Jerry Burge, Doug Jager
- 5 Gordon Jones, Scott Hamilton, Basim Dih
- 6 Kuenja Chung, John Lay
- 7 Thien Bui, James Regehr, Leland Grooms, Michael Davis
- 8 Michael Copeland, Gordan MacRae, Joe Delwiche
- 9 Mathew Plate, Catherine Brown, Bob Pallarino, Roseanne Sakamoto
- 10 Chris Hall, Bill Puckett

### **Office of Radiation and Indoor Air**

Montgomery, AL - Eric Boswell, Jewell Smiley, Steve Taylor  
Las Vegas, NV - David Musick, Emilio Braganza, Jeff Lantz

### **Office of Air Quality Planning and Standards**

Dennis Mikel, Dennis Crumpler, Mark Shanis, Louise Camalier, Jonathan Miller, Lewis Weinstock, Tim Hanley, Joseph Elkins

## *Acronyms and Abbreviations*

AAMG	Ambient Air Monitoring Group
APTI	Air Pollution Training Institute
ADQ	audit of data quality
AMTIC	Ambient Monitoring Technical Information Center
ANSI	American National Standards Institute
AQAD	Air Quality Assessment Division
AQI	Air Quality Index
AQS	Air Quality System
ARM	approved regional method
ASTM	American Society for Testing and Materials
ASQ	American Society for Quality
AWMA	Air and Waste Management Association
CAA	Clean Air Act
CFR	<i>Code of Federal Regulations</i>
CL	confidence limit
CBSA	core-based statistical area
CMSA	combined metropolitan statistical area
CMZ	community monitoring zone
COC	chain of custody
CPU	central processing unit
CSA	combined statistical area
CSN	PM2.5 Chemical Speciation Network
CRM	certified reference material
CV	coefficient of variation
DAS	data acquisition system
DASC	Data Assessment Statistical Calculator
DC	direct current
DQA	data quality assessment
DOP	digital aerosol photometer
DQI	data quality indicators
DQOs	data quality objectives
EDO	environmental data operation
EDERF	energy dispersive x-ray fluorescence
EPA	Environmental Protection Agency
FEM	federal equivalent method
FR	flow rate
FRM	federal reference method
FTIR	fourier transform infrared (spectroscopy)
GC/MS	gas chromatography mass spectrometry
GIS	geographical information systems
GLP	good laboratory practice
GMIS	gas manufactures internal standards
HAP	hazardous air pollutants
HC	hydrocarbon
HPLC	high performance liquid chromatography
HVAC	heating, ventilating and air conditioning
ICP	inductively coupled plasma
IMPROVE	Interagency Monitoring of Protected Visual Environments
IT	information technology
LDL	lower detectable limit
LIMS`	laboratory information management systems
MDL	method detection limit
MFC	mass flow control



***Acronyms and Abbreviations (Continued)***

MPA	monitoring planning area
MQAG	Monitoring and Quality Assurance Group
MQOs	measurement quality objectives
MSA	Metropolitan Statistical Area
NAAQS	National Ambient Air Quality Standards
NACAA	National Association of Clean Air Agencies
NATTS	National Air Toxics Trends Sites
NECTA	New England city and town area
NEIC	National Enforcement Investigations Center
NTAA	National Tribal Air Association
NTEC	National Tribal Environmental Council
NCore	National Core Network
NERL	National Environmental Research Laboratory
NIST	National Institute of Standards and Technology
NF	National Formulary
NPS	National Park Service
NPAP	National Performance Audit Program
NPEP	National Performance Evaluation Program
NOAA	National Oceanic Atmospheric Administration
NTRM	NIST traceable reference material
OAQPS	Office of Air Quality Planning and Standards
OMB	Office of Management and Budget
ORD	Office of Research and Development
ORIA	Office of Radiation and Indoor Air
P&A	precision and accuracy
PAMS	Photochemical Assessment Monitoring Stations
PDFID	Cryogenic Preconcentration and Direct Flame Ionization Detection
PC	personal computer
PE	performance evaluation
PEP	PM <sub>2.5</sub> Performance Evaluation Program
PBMS	performance based measurement system
ppb	part per billion
ppm	part per million
PSD	Prevention of Significant Deterioration
PQAO	primary quality assurance organization
PT	proficiency test
PWD	primary wind direction
QA	quality assurance
QA/QC	quality assurance/quality control
QAARWP	quality assurance annual report and work plan
QAD	EPA Quality Assurance Division
QAM	quality assurance manager
QAO	quality assurance officer
QAPP	quality assurance project plan
QMP	quality management plan
RPO	regional planning organization
RSD	relative standard deviation
SD	standard deviation
SIPS	State Implementation Plans
SLAMS	state and local monitoring stations
SOP	standard operating procedure
SPMS	special purpose monitoring stations
SRM	standard reference material
SRP	standard reference photometer
STN	PM <sub>2.5</sub> Speciation Trends Network (a subset of Chemical Speciation Network)

***Acronyms and Abbreviations (Continued)***

TAD	technical assistance document
TEOM	tapered element oscillating microbalance
TIP	tribal implementation plan
TSA	technical system audit
TSP	total suspended particulate
TTL	transistor-transistor logic
USB	universal serial bus
USGS	U.S. Geological Survey
UTM	universal transverse Mercator
USP	US Pharmacopeial
VAC	volts of alternating current
VOC	volatile organic carbon

## 0. Introduction

### 0.1 Intent of the Handbook

This document is Volume II of a five-volume quality assurance (QA) handbook series dedicated to air pollution measurement systems. Volume II is dedicated to the Ambient Air Quality Surveillance Program and the data collection activities inherent to that program. This guidance is part of a quality management system designed to ensure that the Ambient Air Quality Surveillance Program: (1) provides data of sufficient quality to meet the program's objectives and (2) is implemented consistently across the Nation.

The purpose of the Handbook is twofold. First, the document is intended to assist technical personnel at tribal, state and local monitoring organizations<sup>1</sup> develop and implement a *quality system* for the Ambient Air Quality Monitoring Program. A quality system, as defined by *The American National Standard-Specifications and Guidelines for Quality Systems for Environmental Data Collection and Environmental Technology Programs(ANSI/ASQ E4)*,<sup>2</sup> is “a structured and documented management system describing the policies, objectives, principles, organizational authority, responsibilities, accountability, and implementation plan of an organization for ensuring the quality in its work processes, products, and services. The quality system provides the framework for planning, implementing, and assessing the work performed by the organization and for carrying out required quality assurance (QA) and quality control (QC) activities”. A monitoring organization's quality system for the Ambient Air Quality Surveillance Program is described in its quality assurance project plan (QAPP). Second, the Handbook provides additional information and guidance on the material covered in the Code of Federal Regulations (CFR) pertaining to the Ambient Air Quality Surveillance Program.

The Handbook has been written in a style similar to a QA project plan as specified in the document *EPA Requirements for Quality Assurance Project Plans for Environmental Data Operations (EPA QA/R5)*<sup>3</sup>. Environmental data operations (EDO) refer to the work performed to obtain, use, or report information pertaining to natural surroundings and conditions. The information in this Handbook can be used as guidance in the development of detailed monitoring organization QAPPS.

Earlier versions of the Handbook focused on the six criteria pollutants monitored at the State and Local Ambient Monitoring Stations (SLAMS) and National Ambient Monitoring Stations (NAMS). In 2006, the term NAMS was discontinued and a new national monitoring concept-the National Ambient Air Monitoring Strategy- was adopted. Although the focus will remain on the criteria pollutants, this edition is expanded to cover quality assurance guidance for:

- Photochemical Assessment Monitoring Stations (PAMS);  
<http://www.epa.gov/ttn/amtic/pamsmain.html>;
- Open path monitoring ( <http://www.epa.gov/ttn/amtic/longpath.html> );
- PM<sub>2.5</sub> Chemical Speciation Network (<http://www.epa.gov/ttn/amtic/speciepg.html>);

---

<sup>1</sup> Monitoring organization will be used throughout the handbook to identify any tribal, state or local organization that is implementing an ambient air monitoring program, especially if they are using the data for comparison to the National Ambient Air Quality Standards (NAAQS).

<sup>2</sup> <http://webstore.ansi.org/RecordDetail.aspx?sku=ANSI%2fASQ+E4-2004>

<sup>3</sup> [http://www.epa.gov/quality1/qa\\_docs.html](http://www.epa.gov/quality1/qa_docs.html)

- National Air Toxics Trends Network (NATTS) <http://www.epa.gov/ttn/amtic/airtoxpg.html>; and
- NCore Network (<http://www.epa.gov/ttn/amtic/ncore/index.html>)

This Handbook is not intending to supplant the detailed guidance provided by the programs listed above but to provide general information and pointers, in the form of hyperlinks, where one can go for more detailed information. Extensive use of hyperlinks will be used throughout the document.

## 0.2 Use of the Terms Shall, Must, Should and May

The intent of this handbook is to provide additional guidance on the ambient air monitoring requirements found in the Clean Air Act and 40 CFR Parts 50, 53 and 58. In order to distinguish requirements from guidance, the following terms will be used with consistency.

- ▶ *shall, must-* when the element is a requirement in 40 CFR and the Clean Air Act
- ▶ *should-* when the element is recommended. This term is used when extensive experience in monitoring provides a recommended procedure that would help establish or improve the quality of data or a procedure. The process that includes the term is not required but identifies something that is considered important to data quality that may have alternative methods that can be implemented to achieve the same quality results.
- ▶ *may-* when the element is optional or discretionary. The term also indicates that what is suggested may improve data quality, that it is important to consider, but it is not as important as those that have been suggested using the term “should”.

## 0.3 Use of Footnotes

This document will make extensive use of internet links that will provide the user with access to more detailed information on a particular subject. Due to the limitations of Adobe, full URL addresses must be provided in order for the links to work. Rather than clutter the body of the document with long URL addresses, footnotes will be used to direct the interested reader to the correct link.

## 0.4 Handbook Review and Distribution

The information in this Handbook was revised and/or developed by many of the organizations responsible for implementing the Ambient Air Quality Surveillance Program (see Acknowledgments). It has been peer-reviewed and accepted by these organizations and serves to promote consistency among the organizations collecting and reporting ambient air data.

This Handbook is accessible as a PDF file on the Internet under the AMTIC Homepage:

[\[http://www.epa.gov/ttn/amtic/qabook.html\]](http://www.epa.gov/ttn/amtic/qabook.html)

Recommendations for modifications or revisions are always welcome. Comments should be sent to the appropriate Regional Office Ambient Air Monitoring contact or posted on AMTIC forum<sup>4</sup>. The Handbook Steering Committee will meet quarterly to discuss any pertinent issues and proposed changes.

---

<sup>4</sup> <http://yosemite.epa.gov/oar/Forums.nsf/Forum%5CAMTICByTopic?OpenView&CollapseView>

## 1.0 Program Background

### 1.1 Ambient Air Quality Monitoring Network

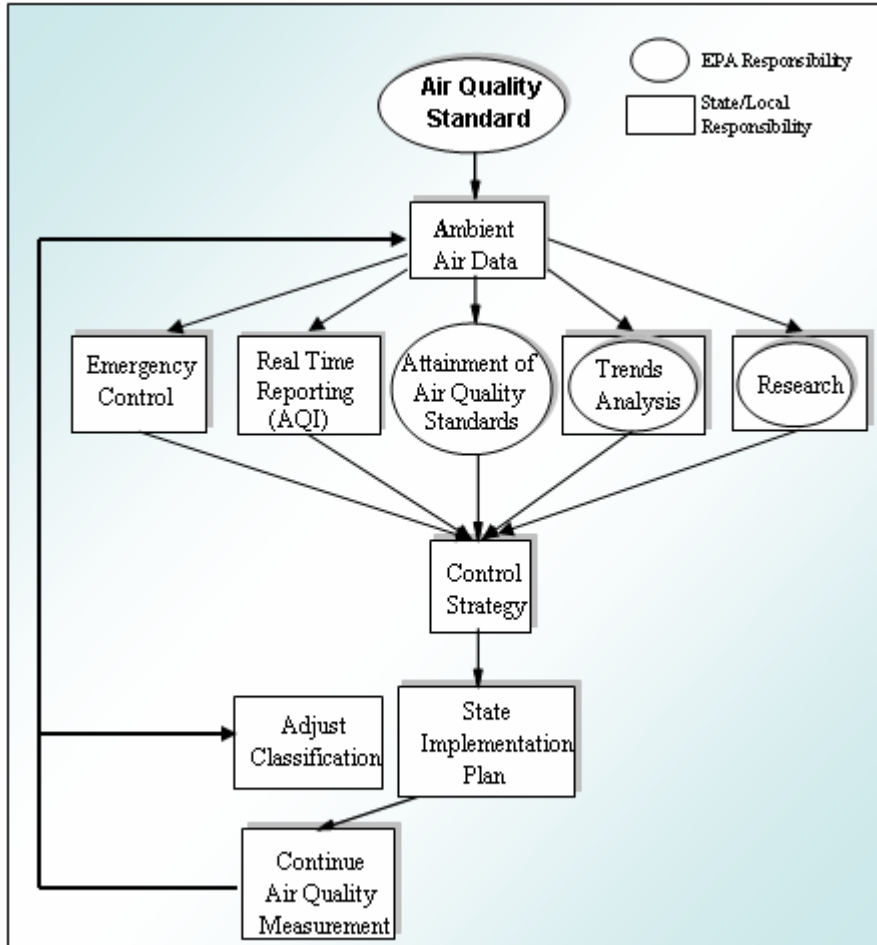

**Figure 1.1 Ambient air quality monitoring process**

40 CFR Part 58, Appendix D requires that monitoring networks be designed for three basic monitoring objectives:

- to provide air pollution data to the general public in a timely manner
- to support compliance with ambient air quality standards and emission strategy development
- to support air pollution research studies

In addition, these monitoring networks can also be developed:

- to activate emergency control procedures that prevent or alleviate air pollution episodes
- to observe pollution trends throughout the region, including non-urban areas

The purpose of this section is to describe the general concepts for establishing the Ambient Air Quality Monitoring Network. The majority of this material, as well as additional details, can be found in the Clean Air Act (CAA)<sup>1</sup>, 40 CFR Parts 50, 53 and 58<sup>2</sup>, and their references.

Between the years 1900 and 1970, the emission of six principal pollutants increased significantly. The principal pollutants, also called criteria pollutants are: particulate matter (PM<sub>10</sub> and PM<sub>2.5</sub>), sulfur dioxide, carbon monoxide, nitrogen dioxide, ozone, and lead. In 1970 the CAA was signed into law. The CAA and its amendments provide the framework for all pertinent organizations to protect air quality.

<sup>1</sup> <http://epa.gov/air/caa/>

<sup>2</sup> <http://www.access.gpo.gov/nara/cfr/cfr-table-search.html>

To meet these basic needs, networks are designed with a variety of types of monitoring sites located to:

- Determine the highest concentration expected to occur in the area covered by the network.
- Measure typical concentrations in areas of high population density.
- Determine the impact of significant sources or source categories on air quality.
- Determine background concentration levels.
- Determine the extent of regional pollutant transport among populated areas; and in support of secondary standards.
- Measure air pollution impacts on visibility, vegetation damage, or welfare-based impacts.

These six objectives will be used during the development of data quality objectives (Section 3). As one reviews the objectives, it becomes apparent that it will be rare that individual sites can be located to meet more than two or three objectives. Therefore, monitoring organizations need to choose the sites that are most representative of its priority objective(s).

Through the process of implementing the CAA, six major categories of monitoring stations or networks that measure the air pollutants have been developed. These networks are described below. In addition, a fact sheet on each network (with the exception of SPMs) can be found in Appendix A.

### ***State and Local Air Monitoring Stations (SLAMS) including Tribal Monitoring Stations***

The SLAMS consist of a network of monitoring stations whose size and distribution is largely determined by the monitoring requirements for NAAQS comparison and the needs of monitoring organizations to meet their respective tribal/state implementation plan (TIP/SIP) requirements. The TIP/SIPs provide for the implementation, maintenance, and enforcement of the national ambient air quality standards (NAAQS) in each air quality control region within a tribe/state. The Handbook is largely devoted to guidance related to the SLAMS network. SLAMS exclude special purpose monitor (SPM) stations and include NCore, PAMS, and all other State or locally operated stations that have not been designated as SPM stations.

### ***Special Purpose Monitoring Stations (SPMs)***

An SPM station means a monitor included in a monitoring organizations network has been designated as a special purpose monitor station in its monitoring network plan and in the Air Quality System (AQS), and which the agency does not count when showing compliance with the minimum monitoring requirements for the number and siting of monitors of various types. SPMs provide for special studies needed by the monitoring organizations to support TIPs/SIPs and other air program activities. These monitors are not counted towards the monitoring organization's minimum requirements established in CFR for monitoring certain pollutants. The SPMs are not permanently established and can be adjusted to accommodate changing needs and priorities. The SPMs are used to supplement the fixed monitoring network as circumstances require and resources permit. If the data from SPMs are used for SIP purposes, they must meet all QA, siting and methodology requirements for SLAMS monitoring. Any SPM data collected by an air monitoring agency using a Federal reference method (FRM), Federal equivalent method (FEM), or approved regional method (ARM) must meet the requirements of 40 CFR Part 58.11, 58.12, and the QA requirements in 40 CFR Part 58, Appendix A or an approved alternative to Appendix A to this part. Compliance with the probe and monitoring path siting criteria in 40 CFR Part 58, Appendix E is optional but encouraged except when the monitoring organization's data objectives are inconsistent with those requirements. Data collected at an SPM using a FRM, FEM, or ARM meeting the requirements of Appendix A must be submitted to AQS according to the requirements of 40 CFR Part

58.16. Data collected by other SPMs may be submitted. The monitoring agency must also submit to AQS an indication of whether each SPM reporting data to AQS meets the requirements of Appendices A and E.

### ***PM<sub>2.5</sub> Chemical Speciation Network (CSN)***<sup>3</sup>

As part of the effort to monitor particulate matter, EPA monitors and gathers data on the chemical makeup of these particles. EPA established a chemical speciation network consisting of approximately 300 monitoring sites. These sites are placed at various SLAMS across the Nation. Fifty-four of these CSN sites, the Speciation Trends Network (STN), will be used to determine, over a period of several years, trends in concentration levels of selected ions, metals, carbon species, and organic compounds in PM<sub>2.5</sub>. Further breakdown on the location or placement of the trends sites requires that approximately 20 of the monitoring sites be placed at existing Photochemical Assessment Monitoring Stations (PAMS). The placement of the remaining trends sites will be coordinated by EPA, the regional offices, and the monitoring organizations. Locations will be primarily in or near larger Metropolitan Statistical Areas (MSAs). The remaining chemical speciation sites will be used to enhance the required trends network and to provide information for developing effective TIPS/SIPs.

The STN is a component of the National PM<sub>2.5</sub> SLAMS. Although the STN is intended to complement the SLAMS activities, STN data will not be used for attainment or nonattainment decisions. The programmatic objectives of the STN network are:

- annual and seasonal spatial characterization of aerosols;
- air quality trends analysis and tracking the progress of control programs;
- comparing, aggregating and evaluating the chemical speciation data set to the data collected from the IMPROVE network; and
- development of emission control strategies.

### ***Photochemical Assessment Monitoring Stations (PAMS)***<sup>4</sup>

Section 182(c)(1) of the 1990 CAA required the Administrator to promulgate rules for the enhanced monitoring of ozone, oxides of nitrogen (NO<sub>x</sub>), and volatile organic compounds (VOC) to obtain more comprehensive and representative data on ozone air pollution. Immediately following the promulgation of such rules, the affected states/tribes were to commence such actions as were necessary to adopt and implement a program to improve ambient monitoring activities and the monitoring of emissions of NO<sub>x</sub> and VOC. Each TIP/SIP for the affected areas must contain measures to implement the ambient monitoring of such air pollutants. The subsequent revisions to 40 CFR 58 required states to establish Photochemical Assessment Monitoring Stations (PAMS) as part of their SIP monitoring networks in ozone nonattainment areas classified as serious, severe, or extreme.

The chief objective of the enhanced ozone monitoring revisions is to provide an air quality database that will assist air pollution control agencies in evaluating, tracking the progress of, and, if necessary, refining control strategies for attaining the ozone NAAQS. Ambient concentrations of ozone and ozone precursors will be used to make attainment/nonattainment decisions, aid in tracking VOC and NO<sub>x</sub> emission inventory reductions, better characterize the nature and extent of the ozone problem, and to evaluate air quality trends. In addition, data from the PAMS will provide an improved database for evaluating photochemical model performance, especially for future control strategy mid-course corrections as part of

---

<sup>3</sup> <http://www.epa.gov/ttn/amtic/speciepg.html>

<sup>4</sup> <http://www.epa.gov/ttn/amtic/pamsmain.html>

the continuing air quality management process. The data will help to ensure the implementation of the most cost-effective regulatory controls.

### ***National Air Toxic Trends Stations (NATTS)<sup>5</sup>***

There are currently 188 hazardous air pollutants (HAPs) or Air Toxics (AT) regulated under the CAA. These pollutants have been associated with a wide variety of adverse health and ecosystem effects. In 1999, EPA finalized the Urban Air Toxics Strategy (UATS). The UATS states that emissions data are needed to quantify the sources of air toxics impacts and aid in the development of control strategies, while ambient monitoring data are needed to understand the behavior of air toxics in the atmosphere after they are emitted. Part of this strategy included the development of the National Air Toxics Trends Stations (NATTS). Specifically, it is anticipated that the NATTS data will be used for:

- tracking trends in ambient levels to evaluate progress toward emission and risk reduction goals;
- directly evaluating public exposure & environmental impacts in the vicinity of monitors;
- providing quality assured data for risk characterization;
- assessing the effectiveness of specific emission reduction activities; and
- evaluating and subsequently improving air toxics emission inventories and model performance.

Currently the NATTS program is made up of 22 monitoring sites; 15 representing urban communities and 7 representing rural communities.

### ***National Core Monitoring Network (NCore)<sup>6</sup>***

The NCore multi-pollutant stations are part of an overall strategy to integrate multiple monitoring networks and measurements. Each state (i.e., the fifty states, District of Columbia, Puerto Rico, and the Virgin Islands) is required to operate at least one NCore site. Monitors at NCore multi-pollutant sites will measure particles (PM<sub>2.5</sub>, speciated PM<sub>2.5</sub>, PM<sub>10-2.5</sub>, speciated PM<sub>10-2.5</sub>), O<sub>3</sub>, SO<sub>2</sub>, CO, nitrogen oxides (NO/NO<sub>2</sub>/NO<sub>y</sub>), and basic meteorology. In addition a number of NCore sites will be selected to measure lead (Pb).

The objective is to locate sites in broadly representative urban (about 55 sites) and rural (about 20 sites) locations throughout the country to help characterize regional and urban patterns of air pollution. The NCore network should be fully operational by 2011.

In many cases, monitoring organizations will collocate these new stations with STN sites measuring speciated PM<sub>2.5</sub> components, PAMS sites already measuring O<sub>3</sub> precursors, and/or NATTS sites measuring air toxics. By combining these monitoring programs at a single location, EPA and its partners will maximize the multi-pollutant information available. This greatly enhances the foundation for future health studies, NAAQS revisions, validation of air quality models, assessment of emission reduction programs, and studies of ecosystem impacts of air pollution.

---

<sup>5</sup> <http://www.epa.gov/ttn/amtic/airtoxpg.html>

<sup>6</sup> <http://www.epa.gov/ttn/amtic/ncore/index.html>



## 1.2 The EPA Quality System Requirements

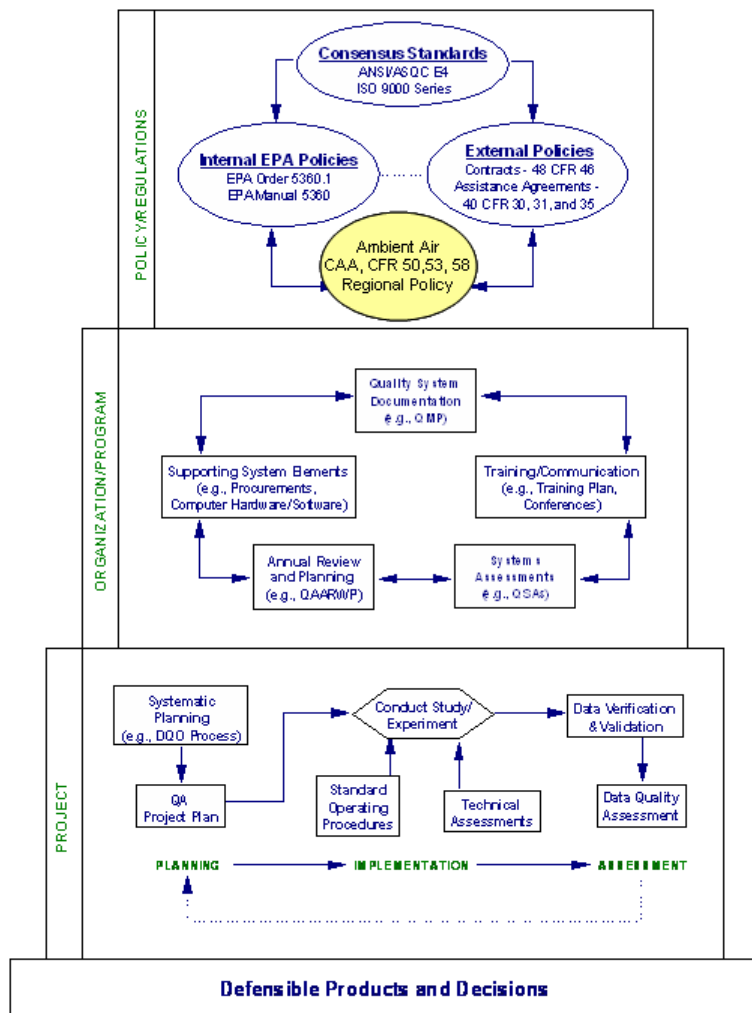

Figure 1.2. Hierarchy of quality system development

- **ANSI/ASQ E4** – EPA’s quality system is based on the document: *American National Standard-Quality Systems for Environmental Data and Technology Programs-Requirements with Guidance for use (ANSI/ASQ E4-2004)*<sup>7</sup>. This document describes a basic set of mandatory specifications and non-mandatory guidelines by which a quality system for programs involving environmental data collection can be planned, implemented, and assessed.
- **Internal Policies**- EPA Order 5360.1<sup>8</sup> expresses the EPA policy in regards to the quality system development for all EPA organizations and by non-EPA organizations performing work on behalf of EPA through extramural agreements. The EPA QA Orders adhere to E4 under the authority of the Office of Management and Budget. Section 1.2.5 below provides more specifics on this Order.

<sup>7</sup> <http://webstore.ansi.org/default.aspx>

<sup>8</sup> <http://www.epa.gov/quality1/>.

A quality system is the “blueprint” or framework by which an organization applies sufficient quality control (QC) and quality assurance (QA) practices to ensure that the results of its environmental programs meet or exceed expectations. It is based upon the model of planning the work, implementing what is planned, assessing the results against the performance criteria, reporting on data quality and making improvements if necessary. Figure 1.2 provides an illustration of the pertinent regulations and policy that drive the development of a quality system. Some important aspects of this figure are explained below.

### 1.2.1 Policy and Regulations

At the highest level, standards and regulations determine what QA is required for the monitoring program and, therefore, set the stage for program and project specific guidance. The standards and regulations pertinent to the Ambient Air Quality Monitoring Program include:

**NOTE:** During development of this document EPA Order 5360.1 was under revision and its new reference may be changed to CIO 2105.0. This Handbook will continue to use 5360.1 as the current reference.

- **External Policies** - Refers to the Code of Federal Regulation (CFR). The references to the external regulations are those that apply to the quality system requirements for external funding. Those most important to the monitoring community are 40 CFR Parts 30, 31 and 35 but are not specific to ambient air monitoring.
- **Ambient Air** -The consensus standards (E4) and internal and external requirements then funnel to the Headquarters and Regional programs (yellow circle) where additional QA requirements, specific to a particular monitoring program, are included. Ambient air requirements include documents like the Clean Air Act (CAA) and 40 CFR Parts 50, 53 and 58 which are specific to ambient air monitoring.

### 1.2.2 Organization/Program

This area in Figure 1.2 refers to the monitoring organization and is used to describe its overall quality system, usually in the form of a **quality management plan (QMP)**<sup>9</sup>. Many monitoring organizations perform a multitude of data collection activities for different media (e.g., air, water, solid waste) where ambient air monitoring might be only one branch in a large organization. It is the responsibility of each organization to have a QMP that demonstrates an acceptable quality system. QMPs are approved by the EPA Regions.

### 1.2.3 Project

The term “project” refers to the specific environmental data operation (EDO) that occurs at the monitoring organization. An environmental data operation refers to the work performed to obtain, use, or report information pertaining to environmental processes and conditions. This handbook provides the majority of the guidance necessary for the monitoring organizations to develop QA project plans specific to its data collection needs. Other guidance has been developed specific to a part of the measurement system (i.e., calibration techniques) or to specific methods. A listing of this guidance is included in Appendix B. It is anticipated that the majority of these documents will be available on the AMTIC bulletin board.

### 1.2.4 Quality System Requirements for EPA Funded Programs

EPA’s national quality system requirements can be found in EPA QA Policy 5360.1<sup>10</sup>. Any organization using EPA funds for the collection of environmental data are covered under 5360.1 and must develop, implement, and maintain a quality system that demonstrates conformance to the minimum specifications of ANSI/ASQC E4-1994 and that additionally provides for the following (excerpt from 5360.1):

1. A quality assurance manager (QAM), or person/persons assigned to an equivalent position, who functions independently of direct environmental data generation, model development, or technology development responsibility; who reports on quality issues to the senior manager

<sup>9</sup> <http://www.epa.gov/quality1/qs-docs/r2-final.pdf>

<sup>10</sup> <http://www.epa.gov/irmpoli8/ciopolicy/2105-0.pdf>

having executive leadership authority for the organization; and who has sufficient technical and management expertise and authority to conduct independent oversight of and assure the implementation of the organization's quality system in the environmental programs of the organization.

2. A Quality Management Plan (QMP), which documents the organization's quality policy, describes its quality system, identifies the environmental programs to which the quality system applies, and which is implemented following approval by the organization's executive leadership.
3. Sufficient resources to implement the quality system defined in the approved QMP.
4. Assessments of the effectiveness of the quality system at least annually.
5. Submittal to the Office of Environmental Information (OEI) of the Quality Assurance Annual Report and Work Plan (QAARWP) for the organization that summarizes the previous years QA and QC activities and outlines the work proposed for the current year (not applicable to air monitoring organizations)
6. Use of a systematic planning approach to develop acceptance or performance criteria for all work covered by this Order.
7. Approved Quality Assurance Project Plans (QAPPs), or equivalent documents defined by the QMP, for all applicable projects and tasks involving environmental data with review and approval having been made by the EPA QAM (or authorized representative defined in the QMP). QAPPs must be approved prior to any data gathering work or use, except under circumstances requiring immediate action to protect human health and the environment or operations conducted under police powers.
8. Assessment of existing data, when used to support Agency decisions or other secondary purposes, to verify that they are of sufficient quantity and adequate quality for their intended use.
9. Implementation of Agency-wide Quality System requirements in all applicable EPA-funded extramural agreements
10. Implementation of corrective actions based on assessment results.
11. Appropriate training, for all levels of management and staff, to assure that QA and QC responsibilities and requirements are understood at every stage of project implementation.

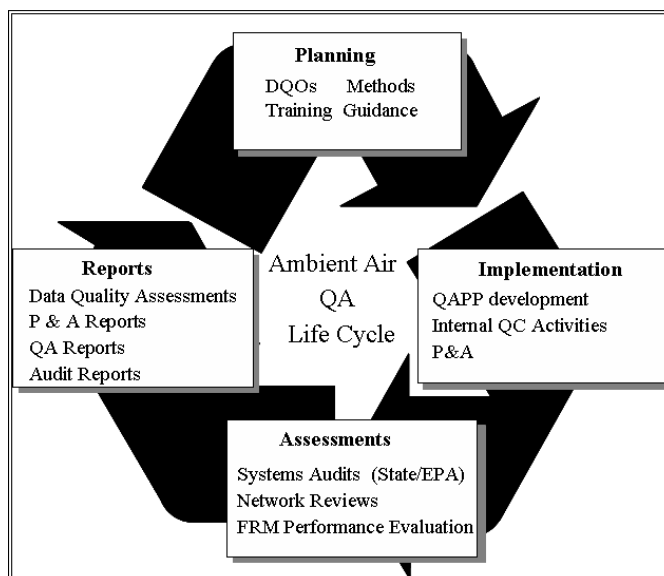

Figure 1.3 Ambient Monitoring Quality Monitoring QA Program

from the outputs of the DQO Process that: (1) clarify the study objective; (2) define the most appropriate

## 1.3 The Ambient Air Monitoring Program Quality System

Figure 1.3 represents the stages of the Ambient Air Quality Monitoring QA Program. OAQPS modified EPA 5360.1 as appropriate in order to provide data of the quality needed to meet the Ambient Air Monitoring Program objectives. The planning, implementation, assessment and reporting tools will be briefly discussed below.

### 1.3.1 Planning

Planning activities include:

**Data Quality Objectives (DQOs)** - DQOs are qualitative and quantitative statements derived

type of data to collect; (3) determine the most appropriate conditions from which to collect the data; and (4) specify tolerable limits on decision errors which will be used as the basis for establishing the quantity and quality of data needed to support the decision. Section 3 will provide more information on the DQO Process.

**Methods-** Reference methods and measurement principles have been written for each criteria pollutant. For monitoring for comparison to the NAAQS, monitoring organizations must use methods that are designated as Federal Reference (FRM) Federal Equivalent (FEM)<sup>11</sup> or approved regional monitor (ARM)<sup>12</sup> for PM<sub>2.5</sub>. ORD NERL implements the FRM/FEM designation program and provides technical assistance in the PM<sub>2.5</sub> ARM process. Approved FRM/FEM methods refer to individual monitoring instruments that either provide a pollutant concentration or provide a sample for further laboratory analysis and must be operated minimally as required in 40 CFR Part 50. Since these methods cannot be applied to the actual instruments acquired by each monitoring organization, they should be considered as guidance for detailed standard operating procedures that would be developed by monitoring organizations as part of an acceptable QAPP.

**Training** - Training is an essential part of any good monitoring program. Training activities are discussed in Section 4.

**Guidance** - This QA Handbook as well as many other guidance documents have been developed for the Ambient Air Quality Monitoring Program. Many of the monitoring networks listed above have developed technical assistance documents and generic QAPPs to help guide personnel in the important aspects of these programs. A list of these documents is included in Appendix B.

### 1.3.2 Implementation

Implementation activities include:

**QMP/QAPP Development** - Each state, local, and tribal organization must develop a QMP and QAPP.

- **QMP** - describes the quality system in terms of the organizational structure, functional responsibilities of management and staff, lines of authority, and required interfaces for those planning, implementing, and assessing activities involving environmental data collection. The QMP is not specific to any particular project, but related to how the monitoring organization implements its quality system.
- **QAPP**- is a formal document describing, in comprehensive detail, the necessary QA/QC and other technical activities that must be implemented to ensure that the results of work performed will satisfy the stated performance criteria, which may be in the form of a data quality objective (DQO). The QAPP is specific to a particular monitoring project. Standard operating procedures (SOPs) are part of the QAPP development process and are vital to the quality of any monitoring program. The QAPP should be detailed enough to provide a clear description of every aspect of the project and include information for every member of the project staff, including samplers, lab staff, and data reviewers. The QAPP facilitates communication among clients, data users, project staff, management, and external reviewers.

---

<sup>11</sup> <http://www.epa.gov/ttn/amtic/criteria.html>

<sup>12</sup> 40 CFR Part 58 Appendix C Section 2.4

Guidance for the development of both QMPs and QAPPs can be found on the EPA Quality Staff's website<sup>13</sup>. In addition, EPA has provided flexibility on how EPA organizations implement this policy, allowing for use of a graded approach. Since EPA funds the collection and use of data for a number of monitoring objectives and for organizations with a broad range of capabilities, flexibility in the QMP and QAPP requirements is necessary. For example, data collection for the purpose of comparison to the National Ambient Air Quality Standards (NAAQS) will require more stringent requirements, while monitoring programs for special purposes may not require the same level of quality assurance. The level of detail of QMPs and QAPPs, as explained by the EPA Quality Staff in the EPA Quality Manual, "should be based on a common sense, graded approach that establishes the QA and QC requirements commensurate with the importance of the work, available resources, and the unique needs of the organization." The ambient air program has developed a graded approach that will help tribes and smaller monitoring organizations develop both a QMP and QAPPs. Appendix C provides information on this approach.

**Internal QC Activities** - The quality control (QC) system is used to fulfill requirements for quality. It is the overall system of technical activities that measure the attributes and performance of a process, item, or service against defined standards to verify that they meet the stated requirements established by the customer. In the case of the Ambient Air Quality Monitoring Network, QC activities are used to ensure that measurement uncertainty is maintained within established acceptance criteria for the attainment of the DQOs.

Federal regulation provides for the implementation of a number of qualitative and quantitative checks to ensure that the data will meet the DQOs. Each of the checks attempt to evaluate phases of measurement uncertainty. Some of these checks are discussed below and in Section 10.

- **Precision and Bias (P & B) Checks** - These checks are described in the 40 CFR Part 58, Appendix A. These checks can be used to provide an overall assessment of measurement uncertainty.
- **Zero/Span Checks** - These checks provide an internal quality control check of proper operation of the measurement system.
- **Annual Certifications** - A certification is the process which ensures the traceability and viability of various QC standards. Standard traceability is the process of transferring the accuracy or authority of a primary standard to a field-usable standard. Traceability protocols are available for certifying a working standard by direct comparison to a NIST-SRM<sup>14, 15</sup>.
- **Calibrations** - Calibrations should be carried out at the field monitoring site by allowing the analyzer to sample test atmospheres containing known pollutant concentrations. Calibrations are discussed in Section 12.

### 1.3.3 Assessments

Assessments, as defined in *ANSI/ASQC-E4* and EPA's document, *Guidance on Technical Audits and Related Assessments for Environmental Data Operations (QA/G-7)*<sup>16</sup>, are evaluation processes used to measure the performance or effectiveness of a system and its elements. It is an all inclusive term used to denote any of the following: audit, performance evaluation, management systems review, peer review,

---

<sup>13</sup> (<http://www.epa.gov/quality1/>)

<sup>14</sup> <http://www.epa.gov/ttn/amtic/files/ambient/criteria/reldocs/4-79-056.pdf>

<sup>15</sup> <http://www.epa.gov/appcdwww/pubs/600r97121/600r97121.htm>

<sup>16</sup> <http://www.epa.gov/quality1/qs-docs/g7-final.pdf>

inspection, or surveillance. Assessments for the Ambient Air Quality Monitoring Program, as discussed in Section 15, include:

**Technical Systems Audits (TSA)** -A TSA is an on-site review and inspection of a State or local agency's ambient air monitoring program to assess its compliance with established regulations governing the collection, analysis, validation, and reporting of ambient air quality data. Both EPA and State organizations perform TSAs. Procedures for this audit are discussed in general terms in Section 15.

**Network Reviews** - The network review is used to determine how well a particular air monitoring network is achieving its required air monitoring objective(s) and how it should be modified to continue to meet its objective(s). Network reviews are discussed in Section 15.

**Performance Evaluations**- Performance evaluations are a type of audit in which the quantitative data generated in a measurement system are obtained independently and compared with routinely obtained data to evaluate the proficiency of an analyst, laboratory, or measurement system. The following performance evaluations, discussed in further detail in Section 15, are included in the Ambient Air Quality Monitoring Program:

- **Monitoring Organization Performance Evaluations (Audits)** - These performance evaluation audits are used to provide an independent assessment of the measurement operations of each instrument being audited. This is accomplished by comparing performance samples or devices of “known” concentrations or values to the values measured by the instruments being audited.
- **National Performance Evaluation Program (NPEP)** – These performance evaluation audits are implemented at the federal level although some programs may be implemented by the monitoring organizations if certain requirements are met.

### 1.3.4 Reports

All concentration data should be assessed in order to evaluate the attainment of the DQOs or the monitoring objectives. These assessments can be documented using the following types of reports:

- **Data quality assessment (DQA)** is the scientific and statistical evaluation to determine if data are of the right type, quality, and quantity to support their intended use (DQOs). QA/QC data can be statistically assessed at various levels of aggregation to determine whether the DQOs have been attained. Data quality assessments of precision, bias, and accuracy can be aggregated at the following three levels.
  - **Monitor**- monitor/method designation
  - **PQAO** - monitors in a method designation, all monitors
  - **National** - monitors in a method designation, all monitors
- **P & B reports** are generated annually and evaluate the precision and bias of data against the acceptance criteria discussed in Section 3.
- **QA reports** provide an evaluation of QA/QC data for a given time period to determine whether the data quality objectives were met. Discussions of QA reports can be found in Sections 16 and 18.
- **Meetings and Calls** at various national meetings and conference calls can be used as assessment tools for improving the network. It is important that information derived from the avenues of communication is appropriately documented.

## 2.0 Program Organization

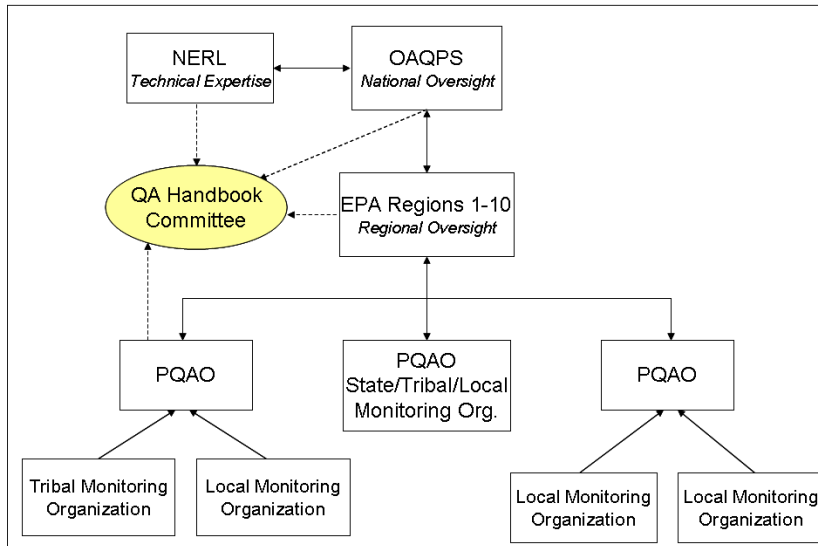

Figure 2.1 Program organization and lines of communication

Federal, state, tribal, and local agencies all have important roles in developing and implementing air monitoring programs. Figure 2.1 identifies the major entities involved in the Ambient Air Quality Monitoring Program, the organizational structure, and the lines of communication. The responsibilities of each organization follow.

## 2.1 Organization Responsibilities

### 2.1.1 EPA Office of Air Quality Planning and Standards (OAQPS)

EPA's responsibility, under the Clean Air Act (CAA) as amended in 1990, includes: setting National Ambient Air Quality Standards (NAAQS) for pollutants considered harmful to the public health and environment; ensuring that these air quality standards are met or attained through national standards and strategies to control air emissions from sources; and ensuring that sources of toxic air pollutants are well controlled.

OAQPS<sup>1</sup> is the organization charged under the authority of the CAA to protect and enhance the quality of the nation's air resources. OAQPS evaluates the need to regulate potential air pollutants and develops national standards; works with state, tribes and local agencies to develop plans for meeting these standards; monitors national air quality trends and maintains a database of information on air pollution and controls; provides technical guidance and training on air pollution control strategies; and monitors compliance with air pollution standards.

Within the OAQPS Air Quality Assessment Division, the Ambient Air Monitoring Group (AAMG)<sup>2</sup> is responsible for the oversight of the Ambient Air Quality Monitoring Network and its quality assurance program. AAMG, relative to quality assurance, has the responsibility to:

- develop a satisfactory quality system for the Ambient Air Quality Monitoring Network;
- ensure that the methods and procedures used in making air pollution measurements are adequate to meet the programs objectives and that the resulting data are of appropriate quality;
- manage the National Performance Evaluation Program (NPEP);

<sup>1</sup> <http://www.epa.gov/air/oarofcs.html>

<sup>2</sup> <http://www.epa.gov/air/oaqps/organization/aqad/aamg.html>



- perform data quality assessments of organizations making air pollution measurements of importance to the regulatory process;
- ensure that guidance pertaining to the quality assurance aspects of the Ambient Air Program are written and revised as necessary; and
- render technical assistance to the EPA Regional Offices and the air pollution monitoring community.

In particular to this Handbook, OAQPS will be responsible for:

- coordinating the Handbook Revision Workgroup responsible for continued improvement of the Handbook;
- seeking resolution on Handbook issues;
- incorporating agreed upon revisions into the Handbook; and
- reviewing and revising the Handbook (Vol II) as necessary.

Specific AAMG leads for the various QA activities (e.g., precision and bias, training, etc.) can be found within the QA Section<sup>3</sup> of the Ambient Monitoring Technical Information Center (AMTIC).

### 2.1.2 EPA Regional Offices

EPA Regional Offices<sup>4</sup> play a critical role in addressing environmental issues related to the monitoring organizations within their jurisdiction and to administering and overseeing regulatory and congressionally mandated programs.

The major quality assurance responsibilities of EPA's Regional Offices in regards to the Ambient Air Quality Program are the coordination of quality assurance matters between the various EPA offices and the monitoring organizations. This role requires that the Regional Offices:

- distribute and explain technical and quality assurance information to the monitoring organizations;
- identify quality assurance needs of the monitoring organization to EPA Headquarters that are "national" in scope;
- provide personnel and the infrastructure to implement NPEP programs;
- provide the personnel with knowledge of QA regulations and with adequate technical expertise to address ambient air monitoring and QA issues;
- ensure monitoring organization have approved quality management plans (QMPs) and quality assurance project plans (QAPPs) prior to routine monitoring;
- evaluate the capabilities of monitoring organizations to measure the criteria air pollutants by implementing network reviews and technical systems audits;
- assess data quality of monitoring organizations within its Regions; and
- assist SLT agencies in defining primary quality assurance organizations within their jurisdiction and in assigning sites to a primary quality assurance organization.

Specific responsibilities as they relates to the Handbook include:

- serving as a liaison to the monitoring organizations for their particular Region;

---

<sup>3</sup> <http://www.epa.gov/ttn/amtic/qacon.html>

<sup>4</sup> <http://www.epa.gov/epahome/locate2.htm>



- serving on the Handbook Revision Workgroup;
- fielding questions related to the Handbook and ambient air monitoring programs;
- reporting issues that would require Handbook Revision Workgroup attention; and
- serving as a reviewer of the Handbook and participating in its revision.

### 2.1.3 Monitoring Organizations

40 CFR Part 58<sup>5</sup> defines a monitoring organization as a “state, local or other monitoring organization (such as tribes) responsible for operating a monitoring site for which quality assurance regulations apply.”

Federally recognized Indian Tribes are Sovereign Nations. However, Section 301(d) of the CAA gives the Administrator the authority to treat an Indian Tribe as a State Agency with some exceptions. Additionally, Section 302 of the CAA states an air pollution control agency can be an agency of an Indian Tribe.

The major responsibility of the monitoring organization<sup>6</sup> is the implementation of a satisfactory monitoring program, which would naturally include the implementation of an appropriate quality assurance program. Implementation of an appropriate quality assurance program includes the development and implementation of a QMP and QAPPs for the Ambient Air Quality Monitoring Program. It is the responsibility of monitoring organizations to implement quality assurance programs in all phases of the data collection process, including the field, its own laboratories, and in any consulting and contractor laboratories which it may use to obtain data.

Monitoring organizations may be identified for reasons such as:

- distinguishing geographic regions (e.g. CA Districts)
- distinguishing different entities or sources of funds (e.g., tribal funds versus state/local funds)
- identifying organizations receiving funds directly from EPA
- identifying organizations that have different methods or objectives for monitoring

Therefore, if the monitoring organization accepts federal funds for monitoring, it will be identified as a monitoring organization that will be required to submit a requisite QMP and QAPPs to cover its monitoring activities. This does not eliminate it from consolidating to a PQAQO with other organizations that it shares common factors, as described in the next section.

Specific responsibilities of monitoring organizations as they relates to the Handbook include:

- serving as a representative for the monitoring organization on the Handbook Revision Workgroup;
- assisting in the development of QA guidance for various sections; and
- reporting issues and comments to Regional Contacts or on the AMTIC Bulletin Board.

### 2.1.4 Primary Quality Assurance Organizations (PQAQOs)

A PQAQO is a monitoring organization or a group of monitoring organizations that share a number of common “QA Factors”. Below is an excerpt on PQAQOs from 40 CFR Part 58, Appendix A:

---

<sup>5</sup> <http://www.access.gpo.gov/nara/cfr/cfr-table-search.html>

<sup>6</sup> <http://www.4cleanair.org/contactUsaLevel.asp>

3.1.1 Each primary quality assurance organization shall be defined such that measurement uncertainty among all stations in the organization can be expected to be reasonably homogeneous, as a result of common factors. Common factors that should be considered by monitoring organizations in defining primary quality assurance organizations include:

- (a) Operation by a common team of field operators according to a common set of procedures;
- (b) Use of a common QAPP or standard operating procedures;
- (c) Common calibration facilities and standards;
- (d) Oversight by a common quality assurance organization; and
- (e) Support by a common management, laboratory or headquarters.

PQAO has very important implications to quality assurance activities. For each pollutant, the number of monitoring sites in a PQAO is used to determine the number and frequency of quality control checks, including the number of collocated monitors and the NPAP/PEP audit frequencies. PQAO is also used to aggregate data for assessments of completeness, precision and bias. EPA will base many of its data quality assessments at the PQAO level. The 5 common factors listed are the key criteria to be used when an agency decides the sites to be considered for aggregation to a PQAO. There are cases where state, local and tribal monitoring organizations have consolidated to one PQAO. The requirement does not intend that all 5 factors have to be fulfilled but that these factors are considered. However, common procedures and a common QAPP should be strongly considered as key to making decisions to consolidate sites into a PQAO. However, the QAPP(s) of the monitoring organizations must refer to the PQAO that the monitoring organization is affiliated with. EPA Regions will need to be aware of monitoring organizations consolidating to a PQAO and have documentation on file to this effect. Figure 2.2 shows the relationship of pollutants monitored at unique sites and how these unique sites are then related to monitoring organizations and primary quality assurance organizations. In the case of PQAO #1, a tribal monitoring organization and local monitoring organization have common factors that allow for consolidation.

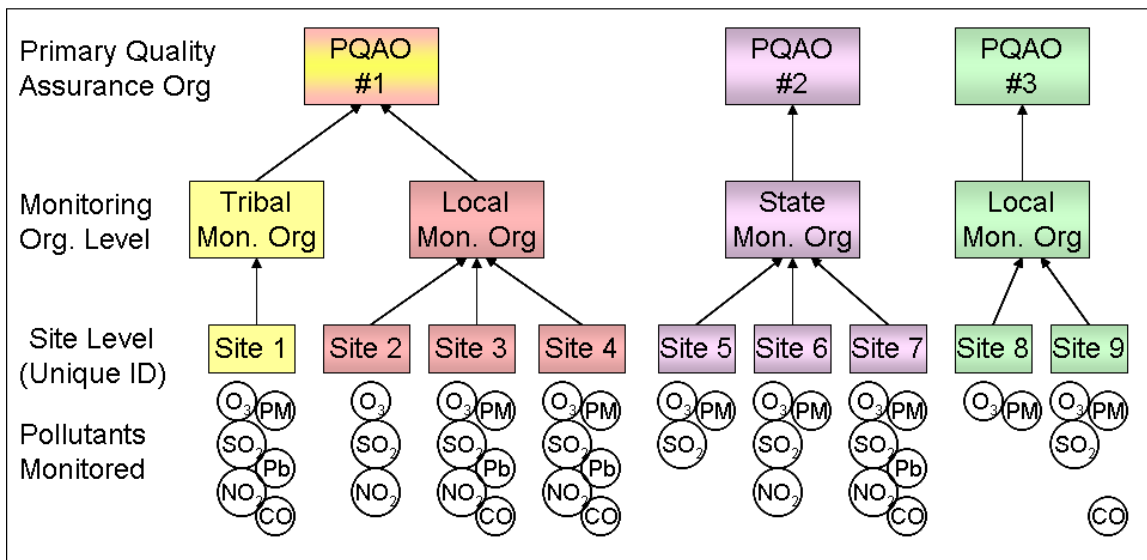

**Figure 2.2 Relationship of monitored pollutants to sites, monitoring organizations and primary quality assurance organizations**

PQAO is identified at the pollutant (monitor) level so two monitoring organizations may consolidate to a single PQAO for one pollutant due to similar methods and QA procedure, but not consolidate for another pollutant where they may have different quality requirements.

### **2.1.5 EPA Office of Research and Development (ORD) National Exposure Research Laboratory (NERL)<sup>7</sup>**

NERL conducts research and development that leads to improved methods, measurements and models to assess and predict exposures of humans and ecosystems to harmful pollutants and other conditions in air, water, soil, and food. The NERL provides the following activities relative to the Ambient Air Quality Monitoring networks:

- develops, improves, and validates methods and instruments for measuring gaseous, semi-volatile, and non-volatile pollutants in source emissions and in ambient air;
- supports multi-media approaches to assessing human exposure to toxic contaminated media through development and evaluation of analytical methods and reference materials, and provides analytical and method support for special monitoring projects for trace elements and other inorganic and organic constituents and pollutants;
- develops standards and systems needed for assuring and controlling data quality;
- assesses whether candidate sampling methods conform to accepted reference method specifications and are capable of providing data of acceptable quality and completeness for determining compliance with applicable National Ambient Air Quality Standards;
- assesses whether emerging methods for monitoring criteria pollutants are “equivalent” to accepted Federal Reference Methods and are capable of addressing the Agency’s research and regulatory objectives; and
- provides an independent audit and review function on data collected by NERL or other appropriate clients.

NERL will continue to assist in the Handbook by:

- providing overall guidance;
- participating in the Handbook review process;
- developing new methods including the appropriate QA/QC; and
- conducting laboratory and field evaluations of sampling and analysis methods to resolve ad hoc technical issues.

## **2.2 Lines of Communication**

In order to maintain a successful Ambient Air Quality Monitoring Program, effective communication is essential. Lines of communication will ensure that decisions can be made at the most appropriate levels in a more time-efficient manner. It also means that each organization in this structure must be aware of the regulations governing the Ambient Air Quality Monitoring Program. In most circumstances, the monitoring organizations first line of contact is the EPA Region. Any issues that require a decision, especially in relation to the quality of data, or the quality system, should be addressed to the EPA Region. A monitoring organization should, in only rare circumstances, contact OAQPS with an issue if it has not initially contacted the EPA Region. If this does occur, OAQPS normally tries to include the pertinent EPA Region in the conversation, or at a minimum, briefs the EPA Region about the issue(s) discussed.

---

<sup>7</sup> <http://www.epa.gov/nerl/>

This is appropriate as long as decisions are not made during these information-seeking communications. If important decisions are made at various locations along the line, it is important that the information is disseminated in all directions in order that improvements to the quality system can reach all organizations in the Program. Nationwide communication will be accomplished through AMTIC and the subsequent revisions to this Handbook.

There are many other routes of communication available in the monitoring community. Three that occur with some frequency and should be used to identify important monitoring and QA issues are:

**National Association of Clean Air Agencies (NACAA)**<sup>8</sup>- represents air pollution control agencies in 53 states and territories and over 165 major metropolitan areas across the United States. It formed in the 1970's to improve their effectiveness as managers of air quality programs. The association serves to encourage the exchange of information among air pollution control officials, to enhance communication and cooperation among federal, state, and local regulatory agencies, and to promote good management of our air resources. Specifically for the Ambient Air Monitoring Program, it facilitates a monthly conference call and has organized a Steering Committee, made up of monitoring organization representatives and EPA, that meet twice a year to discuss issues related to ambient air monitoring.

**National Tribal Air Association (NTAA)**<sup>9</sup>- is an autonomous organization affiliated with the National Tribal Environmental Council (NTEC). The NTAA's mission is to advance air quality management policies and programs, consistent with the needs, interests, and unique legal status of American Indian Tribes, Alaska Natives, and Native Hawaiians. This organization has many similarities to NACCA. It also facilitates a monthly conference call with EPA and holds a national annual meeting.

**EPA Headquarters and Regional Monitoring and QA Calls**- These calls occur monthly and are devoted to relevant monitoring and QA topics where EPA tries to develop consistent approaches to relevant monitoring issues.

Besides the three communication mechanisms described above, there are many others, such as the Regional Planning Organization (RPOs)<sup>10</sup> conference calls/meetings, EPA Regional conference calls/meetings that also serve to communicate the needs and issues of the ambient air monitoring community.

---

<sup>8</sup> <http://www.4cleanair.org/about.asp>

<sup>9</sup> <http://www.ntaatribalair.org/>

<sup>10</sup> <http://epa.gov/visibility/regional.html>

## 2.3 Quality Assurance (QA) Workgroups

Two workgroups have been formed to provide information for improving the Ambient Air Monitoring Program Quality System

- QA Strategy Workgroup
- Handbook Revision Workgroup

### 2.3.1 QA Strategy Workgroup

Organized and chaired by the QA Team Lead of OAQPS/AQAD, the Workgroup consists of Ambient Air Quality Assurance personnel from OAQPS, EPA Regions, and monitoring organizations. The Workgroup members were solicited through NACAA in 2001 in conjunction with OAQPS vision of a new monitoring strategy for the ambient air monitoring community. The goal, established by the Workgroup, was to define the elements of a Quality System. To achieve this goal, the Workgroup scheduled conference calls and meetings. Additionally, the work group meets on an annual basis at the National QA Meeting to discuss issues relevant to quality assurance work in the ambient air monitoring field. For information on the workgroup's activities please refer to: [www.epa.gov/ttn/amtic/qaqcrein.html](http://www.epa.gov/ttn/amtic/qaqcrein.html).

### 2.3.2 The Handbook Revision Workgroup

The Handbook Revision Workgroup is made up of representatives from the following four entities in order to provide representation at the Federal, State and local level:

- **OAQPS** - OAQPS is represented by the coordinator for the Handbook and other representatives of the Ambient Air Quality Monitoring QA Team.
- **Regions** - A minimum of 1 representative from each EPA Regional Office.
- **NERL** -A minimum of one representative. NERL represents historical knowledge of the Handbook series as well as the expertise in the reference and equivalent methods program and QA activities.
- **Monitoring Organizations**- A minimum of 10 representatives of the monitoring organizations.

The mission of the workgroup is the continued clarification and addition of quality assurance procedures as related to ambient air monitoring and the networks. The workgroup provides experiences and insights in the ambient air monitoring field that will assist OAQPS with the task of the continuous improvement of the quality system. This ensures data integrity and provides valid quality indicators for decision makers faced with attainment/nonattainment issues as well as providing quality data to health professionals, academia and environmental professionals using the data.

The Handbook Revision Workgroup will be formed every five years for the purpose of reviewing and revising the Handbook or sections as needed. Issues may surface from comments made by monitoring organizations liaisons, AMTIC bulletin board comments, or the development/revision of regulations.

### 3.0 Data Quality Objectives

Data collected for the Ambient Air Quality Monitoring Program are used to make very specific decisions that can have an economic impact on the area represented by the data. Data quality objectives (DQOs) are qualitative and quantitative statements derived from the DQO Planning Process that clarify the purpose of the study, define the most appropriate type of information to collect, determine the most appropriate conditions from which to collect that information, and specify tolerable levels of potential

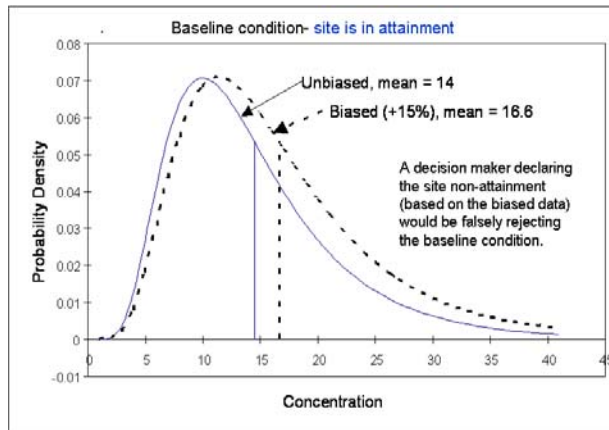

**Figure 3.1** Effect of positive bias on the annual average estimate, resulting in a false rejection error.

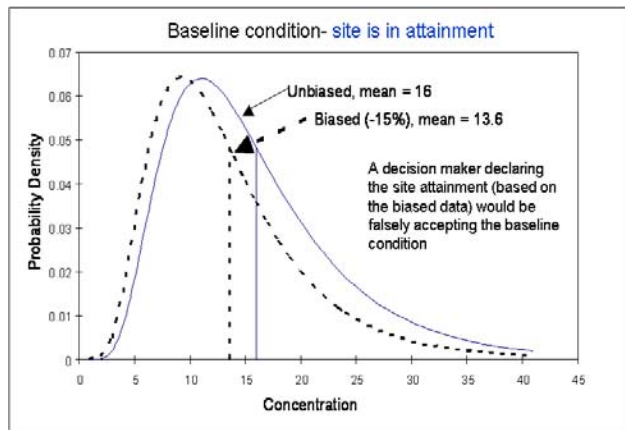

**Figure 3.2** Effect of negative bias on the annual average estimate, resulting in a false acceptance error.

decision errors. Throughout this document, the term *decision maker* is used. This term represents individuals that are the ultimate users of ambient air data and therefore may be responsible for setting the NAAQS (or other objective), developing a quality system, or evaluating the data (e.g., NAAQS comparison). The DQO will be based on the data requirements of the decision maker who needs to feel confident that the data used to make environmental decisions are of adequate quality. The data used in these decisions are never error free and always contain some level of uncertainty. Because of these uncertainties or errors, there is a possibility that decision makers may declare an area “nonattainment” when the area is actually in “attainment” (Fig. 3.1 a false rejection of the baseline condition) or “attainment” when actually the area is in “nonattainment” (Fig. 3.2 false acceptance of the baseline condition)<sup>1</sup>. Figures 3.1 and 3.2 illustrate how false rejection and acceptance errors can affect a NAAQS decision based on an annual mean concentration value of 15 and the baseline condition that the area is in attainment. There are serious political, economic and health consequences of making such decision errors. Therefore, decision makers need to understand and set limits on the probabilities of making incorrect decisions with these data.

In order to set probability limits on decision errors, one needs to understand and control uncertainty. Uncertainty is used as a generic term

to describe the sum of all sources of error associated with an EDO and can be illustrated as follows:

$$S_o^2 = S_p^2 + S_m^2 \quad \text{Equation 3-1}$$

where:

- $S_o$ = overall uncertainty
- $S_p$ = population uncertainty (spatial and temporal)
- $S_m$ = measurement uncertainty (data collection).

<sup>1</sup> “Guidance on Systematic Planning Using the Data Quality Objectives Process,” EPA QA/G-4 U.S. Environmental Protection Agency, QAD, February 2006. <http://www.epa.gov/quality1/qs-docs/g4-final.pdf>



The estimate of overall uncertainty is an important component in the DQO process. Both population and measurement uncertainties must be understood.

**Population uncertainties** - The most important data quality indicator of any ambient air monitoring network is representativeness<sup>2</sup>. This term refers to the degree to which data accurately and precisely represent a characteristic of a population, a parameter variation at a sampling point, a process condition, or a condition. Population uncertainty, the spatial and temporal components of error, can affect representativeness. These uncertainties can be controlled through the selection of appropriate boundary conditions (the monitoring area and the sampling time period/frequency of sampling) to which the decision will apply, and the development of a proper statistical sampling design (see Section 6). Appendix B of the Quality Staff's document titled *Guidance for Quality Assurance Project Plans (EPA/G5)*<sup>3</sup> provides a very good dissertation on representativeness. It does not matter how precise or unbiased the measurement values are if a site is unrepresentative of the population it is presumed to represent. Assuring the collection of a representative air quality sample depends on the following factors:

- selecting a network size that is consistent with the monitoring objectives and locating representative sampling sites;
- identifying the constraints on the sampling sites that are imposed by meteorology, local topography, emission sources, land access and the physical constraints and documenting these; and
- selecting sampling schedules and frequencies that are consistent with the monitoring objectives.

**Measurement uncertainties** are the errors associated with the EDO, including errors associated with the field, preparation and laboratory measurement phases. At each measurement phase, errors can occur, that in most cases, are additive. The goal of a QA program is to control measurement uncertainty to an acceptable level through the use of various quality control and evaluation techniques. In a resource constrained environment, it is most important to be able to calculate and evaluate the total measurement system uncertainty ( $S_m$ ) and compare this to the DQO. If resources are available, it may be possible to evaluate various phases (e.g., field, laboratory) of the measurement system.

Three data quality indicators are most important in determining total measurement uncertainty:

- **Precision** - a measure of agreement among repeated measurements of the same property under identical, or substantially similar, conditions. This is the random component of error. Precision is estimated by various statistical techniques typically using some derivation of the standard deviation.
- **Bias** - the systematic or persistent distortion of a measurement process which causes error in one direction. Bias will be determined by estimating the positive and negative deviation from the true value as a percentage of the true value.
- **Detection Limit** - The lowest concentration or amount of the target analyte that can be determined to be different from zero by a single measurement at a stated level of probability. Due to the fact the NCore sites will require instruments to quantify at lower concentrations, detection limits are becoming more important. Some of the more recent guidance documents suggest that monitoring organizations develop method detection limits (MDLs) for continuous instruments and/or analytical methods. Many monitoring organizations use the default MDL listed in AQS for a particular method. These default MDLs come from instrument vendor advertisements and/or

---

<sup>2</sup> <http://www.epa.gov/quality1/glossary.htm#R>

<sup>3</sup> [http://www.epa.gov/quality1/qa\\_docs.html](http://www.epa.gov/quality1/qa_docs.html)

method manuals. Monitoring organizations should not rely on instrument vendor's documentation on detection limits but determine the detection limits that are being achieved in the field during routine operations. Use of MDL have been listed in the NCore Precursor Gas Technical Assistance Document (TAD)<sup>4</sup>.

Accuracy is a measure of the overall agreement of a measurement to a known value and includes a combination of random error (precision) and systematic error (bias) components of both sampling and analytical operations. This term has been used throughout the CFR and in some sections of this document. Whenever possible, it is recommended that an attempt be made to distinguish measurement uncertainties into precision and bias components. In cases where such a distinction is not possible, the term accuracy can be used.

Other indicators that are considered during the DQO process include **completeness** and **comparability**. Completeness describes the amount of valid data obtained from a measurement system compared to the amount that was expected to be obtained under correct, normal conditions. For example, a PM<sub>2.5</sub> monitor that is designated to sample every sixth day would be expected to have an overall sampling frequency of one out of every six days. If, in a thirty day period, the sampler misses one sample, the completeness would be recorded as four out of five, or 80 percent. Data completeness requirements are included in the reference methods (40 CFR Part 50). Comparability is a measure of the confidence with which one data set or method can be compared to another, considering the units of measurement and applicability to standard statistical techniques. Comparability of datasets is critical to evaluating their measurement uncertainty and usefulness.

### **Performance Based Measurement System Concept: Consistency vs. Comparability**

The NATTS Program proposes to use of the performance based measurement system (PBMS) concept. In simple terms, this means that as long as the quality of data that the program requires (DQOs) are defined, the data quality indicators are identified, and the appropriate measurement quality objectives (MQOs) that quantify that the data quality are met, any sampling/analytical method that meets these data quality requirements should be appropriate to use in the program. The idea behind PBMS is that if the methods meet the data quality acceptance criteria the data are "comparable" and can be used in the program. Previous discussions in this document allude to the need for "nationally consistent data", "utilization of standard monitoring methods" and "consistency in laboratory methods". Comparability is a data quality indicator because one can quantify a number of data quality indicators (precision, bias, detectability) and determine whether two methods are comparable. Consistency is not a data quality indicator and requiring that a particular method be used for the sake of consistency does not assure that the data collected from different monitoring organizations and analyzed by different laboratories will yield data of similar (comparable) quality. Therefore, the quality system will continue to strive for the development of data quality indicators and measurement quality objectives that will allow one to judge data quality and comparability and allow program managers to determine whether or not to require the use of a particular method (assuming this method meets the data quality needs). However, PBMS puts a premium on up-front planning and a commitment from monitoring organizations to adhere to implementing quality control requirements.

The data quality indicator **comparability** must be evaluated in light of a pollutant that is considered a **method-defined parameter**. The analytical result of a pollutant measurement, of a method-defined parameter, has a high dependence on the process used to make the measurement. Most analytical measurements are determinations of a definitive amount of a specific molecule or mixture of molecules. An example of this would be the concentration of carbon monoxide in ambient air. However, other

---

<sup>4</sup> <http://www.epa.gov/ttn/amtic/ncore/guidance.html>



measurements are dependent on the process used to make the measurement. Method-defined parameters include measurements of physical parameters such as temperature and solar radiation which are dependent on the collection height and the design of the instrumentation used. Measurements of particulate mass, especially fine particulate, are also method-defined parameters because they are not "true" measures of particulate mass, being dependent on criteria such as: size cut-points which are geometrically defined; level of volatilization of particulates during sampling; and analytical methods that control the level of moisture associated with particulates at a concentration that may not represent actual conditions. (This should not be interpreted to mean that using a method-defined measurement of particulate is inferior. A "true" measurement of fine particulate in some environments can include a significant contribution from water, which is not a concern from a public/environmental health perspective). When selecting methods or comparing data sets for method-defined parameter it is important to consider that there is no "correct" measurement only a "defined" method. However as mentioned above in the PBMS discussion, there are certain data quality acceptance limits for "defined" methods that can be used to accept alternative methods.

### 3.1 The DQO Process

The DQO process is used to facilitate the planning of EDOs. It asks the data user to focus their EDO efforts by specifying the use of the data (the decision), the decision criteria, and the probability they can accept making an incorrect decision based on the data. The DQO process:

- establishes a common language to be shared by decision makers, technical personnel, and statisticians in their discussion of program objectives and data quality;
- provides a mechanism to pare down a multitude of objectives into major critical questions;
- facilitates the development of clear statements of program objectives and constraints that will optimize data collection plans; and
- provides a logical structure within which an iterative process of guidance, design, and feedback may be accomplished efficiently.

The DQO process contains the following steps:

- **State the problem:** Define the problem that necessitates the study; identify the planning team, examine budget, schedule.
- **Identify the goal:** State how environmental data will be used in meeting objectives and solving the problem, identify study questions, define alternative outcomes.
- **Identify information inputs:** Identify data and information needed to answer study questions.
- **Define boundaries:** Specify the target population and characteristics of interest, define spatial and temporal limits, scale of inference.
- **Develop the analytical approach:** Define the parameter of interest, specify the type of inference, and develop the logic for drawing conclusions from findings.
- **Specify performance or acceptance criteria:**
  - *Decision making (hypothesis testing):* Specify probability limits for false rejection and false acceptance decision errors.
  - *Estimation approaches:* Develop performance criteria for new data being collected or acceptable criteria for existing data being considered for use.
- **Develop the plan for obtaining data:** Select the resource-effective sampling and analysis plan that meets the performance criteria.

The DQO Process is fully discussed in the document titled *Guidance on Systematic Planning using the Data Quality Objectives Process (EPA QA/G-4)*, and is available on the EPA's Quality System for Environmental Data and Technology website<sup>5</sup>. For an illustration of how the DQO process was applied to a particular ambient air monitoring problem, refer to the EPA document titled *Systematic Planning: A Case Study of Particulate Matter Ambient Air Monitoring*<sup>6</sup>.

### 3.2 Ambient Air Quality DQOs

As indicated above, the first steps in the DQO process are to identify the problems that need to be resolved and the objectives to be met. As described in Section 2, the ambient air monitoring networks are designed to collect data to meet three basic objectives:

1. provide air pollution data to the general public in a timely manner;
2. support compliance with air quality standards and emission strategy development; and
3. support air pollution research.

These different objectives could potentially require different DQOs, making the development of DQOs complex. However, if one were to establish DQOs based upon the objective requiring the most stringent data quality requirements, one could assume that the other objectives could be met. Therefore, the DQOs have been initially established based upon ensuring that decision makers can make comparisons to the NAAQS within a specified degree of certainty. OAQPS has established formal DQOs for PM<sub>2.5</sub>, Ozone, the NCore Precursor Gas Network, the PM<sub>2.5</sub> Speciation Trends Network (STN)<sup>7</sup>, and the National Air Toxics Trends Network (NATTS)<sup>8</sup>. As the NAAQS for the other criteria pollutants come up for review, EPA will develop DQOs for these pollutants.

### 3.3 Measurement Quality Objectives

Once a DQO is established, the quality of the data must be evaluated and controlled to ensure that it is maintained within the established acceptance criteria. Measurement Quality Objectives (MQOs) are designed to evaluate and control various phases (e.g., sampling, transportation, preparation, analysis) of the measurement process to ensure that total measurement uncertainty is within the range prescribed by the DQOs. MQOs can be defined in terms of the following data quality indicators: precision, bias, representativeness, detection limit, completeness and comparability as described in Section 3.0.

MQOs can be established to evaluate overall measurement uncertainty, as well as for an individual phase of a measurement process. As an example, the precision DQO for PM<sub>2.5</sub> is 10% and it is based on 3 years of collocated precision data collected at a PQA level. Since only 15% of the sites are collocated, the data can be used to control the quality from each site and since the results can be effected by field and laboratory processes one cannot pinpoint a specific phase of the measurement system when a precision result is higher than the 10% precision goal. Therefore individual precision values greater than 10% may be tolerated as long as the overall 3-year DQO is achieved. In contrast, the flow rate audit, which is specific to the appropriate functioning of the PM<sub>2.5</sub> sampler, has an MQO of  $\pm 4\%$  of the audit standard and  $\pm 5\%$  of the design value. This MQO must be met each time or the instrument is recalibrated. In summary, since uncertainty is usually additive, there is much less tolerance for uncertainty for individual

---

<sup>5</sup> [http://www.epa.gov/quality1/qa\\_docs.html](http://www.epa.gov/quality1/qa_docs.html)

<sup>6</sup> <http://www.epa.gov/quality1/qs-docs/casestudy2-final.pdf>

<sup>7</sup> <http://www.epa.gov/ttn/amtic/specguid.html>

<sup>8</sup> <http://www.epa.gov/ttn/amtic/airtoxqa.html>

phases of a measurement system (e.g., flow rate) since each phase contributes to overall measurement. As monitoring organizations develop measurement specific MQOs they should think about being more stringent for individual phases of the measurement process since it will help to keep overall measurement uncertainty within acceptable levels.

For each of these indicators, acceptance criteria can be developed for various phases of the EDO. Various parts of 40 CFR Parts 50 and 58 have identified acceptance criteria for some of these indicators. In theory, if these MQOs are met, measurement uncertainty should be controlled to the levels required by the DQO. Table 3-1 is an example of an MQO table for ozone. MQO tables for the remaining criteria pollutants can be found in Appendix D. The ozone MQO table has been “re-developed” into what is known as a validation template. In June 1998, a workgroup of QA personnel from the monitoring organizations, EPA Regional Offices, and OAQPS was formed to develop a procedure that could be used by monitoring organizations for consistent use of MQOs and the validation of the criteria pollutants across the US. The workgroup developed three tables of criteria:

**Critical Criteria-** deemed critical to maintaining the integrity of a sample (or ambient air concentration value) or group of samples were placed on the first table. Observations that do not meet each and every criterion on the critical table should be invalidated unless there are compelling reason and justification for not doing so. Basically, the sample or group of samples for which one or more of these criteria are not met is invalid until proven otherwise.

**Operational Criteria Table-** important for maintaining and evaluating the quality of the data collection system. Violation of a criterion or a number of criteria may be cause for invalidation. The decision should consider other quality control information that may or may not indicate the data are acceptable for the parameter being controlled. Therefore, the sample or group of samples for which one or more of these criteria are not met is suspect unless other quality control information demonstrates otherwise. The reason for not meeting the criteria should be investigated, mitigated or justified.

**Systematic Criteria Table-** include those criteria which are important for the correct interpretation of the data but do not usually impact the validity of a sample or group of samples. For example, the data quality objectives are included in this table. If the data quality objectives are not met, this does not invalidate any of the samples but it may impact the error rate associated with the attainment/non-attainment decision.

More information about data validation and the use of the validation templates can be found in Section 17.

**Table 3-1 Measurement Quality Objectives for Ozone Developed into a Validation Template**

Requirement	Frequency	Acceptance Criteria
<b>Critical Criteria</b>		
<b>One Point QC Check Single analyzer</b>	1/ 2 weeks	$\leq 7\%$ (percent difference)
<b>Zero/span check</b>	1/ 2 weeks	Zero drift $\leq \pm 3\%$ of full scale Span drift $\leq \pm 7\%$
<b>Operational Criteria</b>		
<b>Shelter Temperature</b>		
Temperature range	<b>Daily</b> (hourly values)	20 to 30° C. (Hourly ave) or per manufacturers specifications if designated to a wider temperature range
Temperature Control	Daily (hourly values)	$\leq \pm 2^\circ$ C SD over 24 hours
<b>Precision (using 1-point QC checks)</b>	Calculated annually and as appropriate for design value estimates	90% CL CV $\leq 7\%$
<b>Bias (using 1-point QC checks)</b>	Calculated annually and as appropriate for design value estimates	95% CL $\leq \pm 7\%$
<b>Annual Performance Evaluation</b>		
Single analyzer	Every site 1/year 25 % of sites quarterly	Percent difference at each audit level $\leq 15\%$
PQAO	annually	95% of audit percent differences fall within the one point QC check 95% probability intervals at PQAO level of aggregation
<b>Federal Audits (NPAP)</b>	1/year at selected sites 20% of sites audited	Mean absolute difference $\leq 10\%$
<b>State audits</b>	1/year	State requirements
<b>Calibration</b>	Upon receipt/adjustment/repair and 1/6 months if manual zero/span performed biweekly 1/year if continuous zero/span performed daily	All points within $\pm 2\%$ of full scale of best-fit straight line
<b>Zero Air</b>		Concentrations below LDL
<b>Gaseous Standards</b>		NIST Traceable (e.g., EPA Protocol Gas)
<b>Zero Air Check</b>	1/year	Concentrations below LDL
<b>Ozone Transfer standard</b>		
Qualification and certification	Upon receipt of transfer standard	$\pm 4\%$ or $\pm 4$ ppb (whichever greater)
Recertification to local primary standard	Beginning and end of O <sub>3</sub> season or 1/6 months whichever less	RSD of six slopes $\leq 3.7\%$ Std. Dev. of 6 intercepts 1.5 New slope = $\pm 0.05$ of previous
<b>Ozone local primary standard</b>		
Certification/recertification to Standard Photometer	1/year	single point difference $\leq \pm 5\%$ (preferably $\pm 3\%$ )
(if recertified via a transfer standard)	1/year	Regression slopes = $1.00 \pm 0.03$ and two intercepts are $0 \pm 3$ ppb
<b>Detection</b>		
Noise	NA	0.003 ppm
<b>Systematic Criteria</b>		
<b>Standard Reporting Units</b>	All data	ppm (final units in AQS)
<b>Completeness</b> (seasonal)	Daily	75% of hourly averages for the 8-hour period
<b>Sample Residence Times</b>		$< 20$ seconds
<b>Sample Probe, Inlet, Sampling train</b>		Pyrex Glass or Teflon
<b>Siting</b>		Un-obstructed probe inlet
<b>EPA Standard Reference Photometer Recertification</b>	1/year	Regression slope = $1.00 \pm 0.01$ and intercept $< 3$ ppb

## 4.0 Personnel Qualifications and Training

### 4.1 Personnel Qualifications

Ambient air monitoring personnel may be required to perform a number of functions that are important to the quality of data. Table 4-1 identifies these functions and provides some of the key activities within the functional category. Once the list is completed for a monitoring organization, it can be used in the development of position descriptions for recruitment and training programs.

Not all functions are needed for the entire duration of the project. Monitoring organizations may feel that it can contract some of the functions that are needed. For example, an organization may wish to contract the information technology (IT) function to have the monitoring instruments connected to a data logging system that would transfer data to a local data base and eventually to an external data base like AQS. This part of the process might be considered a “one-time” event needing a particular expertise whose function might not require a full time person. However, it is critical that someone within the program understands this IT function to ensure data collection is operating properly on a day-to-day basis.

**Table 4-1 Monitoring Functions that Need Some Level of Staffing or Expertise**

Function	Activities
Procurement	<ul style="list-style-type: none"> <li>- Purchasing capital equipment and consumables</li> <li>- Developing contracts and maintenance agreements</li> <li>- Applying for EPA grants</li> </ul>
Technical	<ul style="list-style-type: none"> <li>- Setting up a monitoring site, electricity, communications</li> <li>- Developing standard operating procedures</li> <li>- Selecting and installing monitoring equipment</li> <li>- Calibrating equipment, performing quality control</li> <li>- Shelter and equipment maintenance</li> </ul>
Data Analysis (Statistical)	<ul style="list-style-type: none"> <li>- Understanding population and measurement uncertainty</li> <li>- Developing sampling designs</li> <li>- Developing networks to achieve objectives</li> <li>- Assessing/interpreting data (data quality assessments)</li> </ul>
Quality Assurance	<ul style="list-style-type: none"> <li>- Developing quality systems, QMPs/QAPPs</li> <li>- Developing data quality objectives</li> <li>- Implementing technical systems audits, performance evaluations</li> <li>- Validating data</li> <li>- QA reporting</li> </ul>
Information Technology	<ul style="list-style-type: none"> <li>- Selecting information technology (data loggers and local data base)</li> <li>- Developing analyzer outputs to data loggers and data transfer to local data base</li> <li>- Transferring data from local data base to external data repositories (AQS, etc.)</li> </ul>

Personnel assigned to ambient air monitoring activities are expected to have the educational, work experience, responsibility, personal attributes and training requirements for their positions. In some cases, certain positions may require certification and/or recertification. These requirements should be outlined in the position advertisement and in personal position descriptions. Records on personnel qualifications and training should be maintained and accessible for review during audit activities (unless the records are maintained as part of confidential personnel records). These records should be retained as described in Section 5.

## 4.2 Training

Adequate education and training are integral to any monitoring program that strives for reliable and comparable data. It is recommended that monitoring organizations maintain some requirements for air personnel qualifications (combination of education and experience). Training is aimed at increasing the effectiveness of employees and their organization. As part of a quality assurance program, EPA QA/G-10, *Guidance for Developing a Training Program for Quality System*<sup>1</sup> suggests the development of operational procedures for training. These procedures should include information on:

- personnel qualifications- general and position specific
- training requirements - by position
- frequency of training

Appropriate training should be available to employees supporting the Ambient Air Quality Monitoring Program, commensurate with their duties. Such training may consist of classroom lectures, workshops, web-based courses, teleconferences, vendor provided, and on-the-job training.

Along with suggested training, there are some EPA programs that require mandatory training and/or certifications. These programs include, but are not limited to, the National Performance Audit Program (NPAP), Performance Evaluation Program (PEP), Interagency Monitoring of Protected Visual Environments (IMPROVE), and PM<sub>2.5</sub> Speciation Trends Network Audit Program. All personnel performing audits in these projects or programs are required to possess mandatory training or a current certification issued by the EPA Office responsible for the monitoring program.

EPA encourages regional planning organizations and monitoring organizations to develop training programs that require some level of certification.

### 4.2.1 Suggested Training

Over the years, a number of courses have been developed for personnel involved with ambient air monitoring and quality assurance aspects. Formal QA/QC training is offered through the following organizations:

- Air Pollution Training Institute (APTI) <http://www.epa.gov/apti/>
- Air & Waste Management Association (AWMA) <http://www.awma.org/>
- American Society for Quality Control (ASQC) <http://www.asq.org/>
- EPA Quality Assurance Staff <http://www.epa.gov/quality1/>
- EPA Regional Offices <http://www.epa.gov/epahome/locate2.htm>
- EPA Ambient Monitoring Technology Information Center (AMTIC) Technology Transfer Network (<http://www.epa.gov/ttn/amtic/training.html>)

In addition, OAQPS uses contractors and academic institutions to develop and provide training for data collection activities that support regulatory efforts throughout EPA and monitoring organizations. In addition, instrument and data management manufacturers provide training on the equipment they sell. Sometimes this can be added to the purchase cost.

---

<sup>1</sup> <http://www.epa.gov/quality1/qs-docs/g10-final.pdf>

Table 4-2 provides a suggested sequence of core QA-related ambient air monitoring courses for ambient air monitoring staff by job position. The suggested course sequences assume little or no experience in QA/QC or air monitoring but some courses may have pre-requisites. Persons having experience in the subject matter described in the courses would select courses according to their appropriate experience level. Courses not included in the core sequence would be selected according to individual responsibilities, preferences, and available resources.

**Table 4-2 Suggested Sequence of Core QA-related Ambient Air Training Courses for Ambient Air Monitoring and QA Personnel**

Source-Sequence	Course Title (SI = self instructional)	Field	Lab	QC-Supv.	Data Mgt.	Mon Supv.	QA	QA Mgt.
APTI- SI:422	Air Pollution Control Orientation Course	X	X	X		X	X	X
APTI 452	Principles and Practices of Air Pollution Control	X		X		X	X	X
APTI -SI:100	Mathematics Review for Air Pollution Control	X	X					
QS- QA1	Orientation to Quality Assurance Management					X	X	X
APTI-SI:434	Introduction to Ambient Air Monitoring	X	X	X	X	X	X	X
APTI -SI:471	General Quality Assurance Considerations for Ambient Air Monitoring	X	X	X	X	X	X	X
APTI- SI:409	Basic Air Pollution Meteorology	X		X		X	X	X
APTI SI:473A	Beginning Environmental Statistical Techniques (Revised)	X	X	X	X	X	X	X
APTI-470	Quality Assurance for Air Pollution Measurement Systems			X		X	X	X
QS-QA2	Data Quality Objectives Workshop					X	X	X
QS-QA3	Quality Assurance Project Plan			X		X	X	X
APTI-435	Atmospheric Sampling	X	X	X		X	X	
No Source	Basic Electronics	X		X		X		
APTI-SI:476B	Continuous Emission Monitoring Systems - Operation & Maintenance of Gas Monitors	X		X		X	X	
APTI-474	Continuous Emission Monitoring	X		X		X	X	
APTI-SI:433	Network Design and Site Selection for Monitoring PM <sub>2.5</sub> and PM <sub>10</sub> in Ambient Air			X		X	X	
APTI-464	Analytical Methods for Air Quality Standards		X	X		X	X	
APTI	Chain Of Custody Procedures for Samples and Data	X	X	X	X	X	X	X
APTI- SI:436	Site Selection for Monitoring SO <sub>2</sub>	X		X		X	X	
QAQPS	AQS Training (annual AQS conference)				X	X	X	
QS- QA4	Data Quality Assessment					X	X	X
QS- QA5	Management Systems Review					X	X	X
APTI-SI:473B	Introduction to Environmental Statistics				X	X	X	X
AWMA QA6	Quality Audits for Improved Performance						X	X
ASQC-STAT1	Statistics for Effective Decision Making			X	X	X	X	X

## 5.0 Documentation and Records

Organizations that perform Environmental Data Operations (EDO) and management activities must establish and maintain procedures for the timely preparation, review, approval, issuance, use, control, revision and maintenance of documents and records. Each organization should have a documented records management policy with the following elements addressed:

1. A list of files considered the official records and their media type i.e., paper, electronic
2. Schedule for retention and disposition of records
3. Storage and retrieval system of records
4. Person(s) responsible at each level of storage and retrieval for records
5. Assignment of appropriate levels of security

This information should be included in a monitoring organization's Quality Assurance Project Plan. In ambient air monitoring, the majority of the records are data and related information. However, these steps could be used for other records management practices in a monitoring organization. Please refer to Section 14 for further information and the EPA records website<sup>1</sup>

**Table 5-1 Types of Information that Should be Retained Through Document Control.**

Categories	Record/Document Types
Management and Organization	State Implementation Plan Reporting agency information Organizational structure of monitoring program Personnel qualifications and training Quality management plan Document control plan Support contracts
Site Information	Network description Site characterization file Site maps/pictures
Environmental Data Operations	QA Project Plans (QAPPs) Standard operating procedures (SOPs) Field and laboratory notebooks Sample handling/custody records Inspection/maintenance records
Raw Data	Any original data (routine and QC)
Data Reporting	Air quality index report Annual SLAMS air quality information Data/summary reports Journal articles/papers/presentations
Data Management	Data algorithms Data management plans/flowcharts
Quality Assurance	Control charts and strip charts Data quality assessments QA reports System audits Network reviews

A document, from a records management perspective, is a volume that contains information that describes, defines, specifies, reports, certifies, or provides data or results pertaining to environmental programs. As defined in the Federal Records Act of 1950 and the Paperwork Reduction Act of 1995 (now 44 U.S.C. 3101-3107), records are: "...books, papers, maps, photographs, machine readable materials, or other documentary materials, regardless of physical form or characteristics, made or received by an agency of the United States Government under Federal Law or in connection with the transaction of public business and preserved or appropriate for preservation by that agency or its legitimate successor as evidence of the organization, functions, policies, decisions,

<sup>1</sup> <http://www.epa.gov/records/>



procedures, operations, or other activities of the Government or because of the informational value of data in them...". This section will provide guidance of documentation and records for the Ambient Air Quality Monitoring Program.

Table 5-1 represents the categories and types of records and documents that are applicable for document control. Information on key documents in each category follows. It should be noted that the list contains documents that may not be applicable to particular organizations and, therefore, is not meant to be a list of required documentation. This list should also not be construed as the definitive list of record and document types.

### **Electronic Records**

Today, more data are generated and retained electronically in the ambient air monitoring community. The majority of the documentation referred to in this section can be an electronic record. Retention of electronic records<sup>2</sup> is included in the above definition. It is recommended that electronic as well as paper records be stored in a logical order for ease of access should it be necessary. This is discussed more in-depth in Section 14.

### **Statute of Limitations**

As stated in 40 CFR Part 31.42, in general, all information considered as documentation and records should be retained for 3 years from the date the grantee submits its final expenditure report unless otherwise noted in the funding agreement. However, if any litigation, claim, negotiation, audit or other action involving the records has been started before the expiration of the 3-year period, the records must be retained until completion of the action and resolution of all issues that arise from it, or until the end of the regular 3-year period, whichever is later. For clarification purposes, the retention of samples produced as a result of required monitoring may differ depending on the program and/or purpose collected. For example, CFR requires that PM<sub>2.5</sub> filter samples be archived for a minimum of one year. For retention of samples for a specific program please refer to the appropriate reference in CFR for the individual program.

## **5.1 Management and Organization**

How the monitoring organization handles the document types listed in Table 5-1 for this category can be found in a single document, a quality management plan, which is a blueprint for how an organization's quality management objectives will be attained. The Quality Management Plan documents management practices, including QA and QC activities, used to ensure that the results of technical work are of the type and quality needed for their intended use. The EPA Quality Staff provide requirements for quality management plans<sup>3</sup> that monitoring organizations may find helpful.

## **5.2 Site Information**

Site information provides vital data about each monitoring site. Historical site information can help determine and evaluate changes in measurement values at the site. This information should be kept to characterize the site through time. The Air Quality System (AQS) Site File is one record used to capture and retain site information. Another source where site information is provided is the quality assurance

---

<sup>2</sup> <http://www.epa.gov/records/tools/erks.htm>

<sup>3</sup> EPA Requirements for Quality Management Plans (QA/R-2) [http://www.epa.gov/quality1/qa\\_docs.html](http://www.epa.gov/quality1/qa_docs.html)

project plan. This should include specific documentation of site characteristics for each monitoring station. This information will assist in providing objective inputs into the evaluation of data gathered at that site.

Most ambient air agencies retain these records in paper and/or electronic file format. Included in a site information file are maps and pictures of an individual site. Because monitoring organizations are required to file an annual network plan and perform network assessments at a minimum of every five years, (40 CFR Part 58.10), this information should be retained and updated periodically by both the agency responsible for the site and/or the office responsible for reviewing the site information as needed for the network assessment process. Typically, the kinds of information found in a site identification record should include:

1. Purpose of measurements (e.g., monitoring to determine compliance with air quality standards).
2. Station type.
3. Instrumentation and methods (manufacturer's model number, pollutant measurement technique, etc.).
4. Sampling system.
5. Spatial scale of the station (site category--i.e., urban/industrial, suburban/commercial, etc.; physical location--i.e., address, AQCR, UTM coordinates, etc.).
6. Influential pollutant sources (point and area sources, proximity, pollutant density, etc.).
7. Topography (hills, valleys, bodies of water, trees; type and size, proximity, orientation, etc., picture of a 360 degree view from the probe of the monitoring site).
8. Atmospheric exposure (unrestricted, interferences, etc.).
9. Site diagram (measurement flowsheet, service lines, equipment configuration, etc.).
10. Site audits.

### **5.3 Environmental Data Operations**

A quality assurance program associated with the collection of ambient air monitoring data must include an effective procedure for preserving the integrity of the data. Ambient air monitoring results and in certain types of measurements, the sample itself, may be essential elements in proving the validity of the data or the decisions made using the data. Data can not be admitted as evidence unless it can be shown that they are representative of the conditions that existed at the time that the data (or sample) was collected. Therefore, each step in the sampling and analysis procedure must be carefully monitored and documented. There are basically four elements in the evidentiary phase of an overall quality assurance program:

1. Data collection - includes measurement preparation and identification of the sample, location, time, and conditions during the measurements in the form of data sheets, logbooks, strip charts, and raw data.
2. Sample and/or measurement result handling - includes evidence that the sample and data were protected from contamination and tampering during transfer between people and from the sampling site to the evidence locker (i.e., chain of custody) and during analysis, transmittal, and storage.
3. Analysis - includes evidence that samples and data were properly stored prior to and after analysis interpretation, and reporting.
4. Preparation and filing of measurement report - includes evidentiary requirements and retention of records.

Failure to include any one of these elements in the collection and analysis of ambient air monitoring data may render the results of the program inadmissible as evidence, or may seriously undermine the credibility of any report based on these data.

Environmental data operations include all the operations required to successfully measure and report a value within the data quality objectives. Documentation for environmental data operations would include:

- **QA Project Plans** - Documents how environmental data operations are planned, implemented, and assessed during the life cycle of a program, project, or task (see below).
- **Standard operating procedures (SOPs)**- Written documents that give detailed instruction on how a monitoring organization will perform daily tasks: field, laboratory and administrative. SOPs are a required element of a QAPP and therefore any EDO must include these (see below).
- **Field and laboratory notebooks**- Any documentation that may provide additional information about the environmental data operation (e.g., calibration notebooks, strip charts, temperature records, site notes, maintenance records etc.) (see below).
- **Sample handling and/or custody records**- Records tracing sample and data handling from the site through analysis, including transportation to facilities, sample storage, and handling between individuals within facilities. (Section 12 provides more information on this activity.)

### **Quality Assurance Project Plan**

As mentioned in the assistance agreement sections of 40 CFR Parts 30.54 (Non-State and Local Gov.) and 31.45 (State and Local Gov.) quality assurance programs must be established. In addition to the grant requirements, 40 CFR Part 58, Appendix A<sup>4</sup> states that each quality assurance program must be described in detail in accordance with the *EPA Requirements for Quality Assurance Project Plans*<sup>5</sup>.

### **Standard Operating Procedures**

In order to perform sampling and analysis operations consistently, standard operating procedures (SOPs) must be written as part of the QAPP. SOPs are written documents that detail the method for an operation, analysis, or action with thoroughly prescribed techniques and steps, and are officially approved as the method for performing certain routine or repetitive tasks. Although not every activity in the field/laboratory needs to be documented, the activities that could potentially cause measurement uncertainties, or significant variance or bias, should be described in an SOP. In general, approval of SOPs occurs during the approval of the QAPP. Individuals with appropriate training and experience with the particular SOPs in the QAPP need to review the SOPs.

SOPs should ensure consistent conformance with organizational practices, serve as training aids, provide ready reference and documentation of proper procedures, reduce work effort, reduce error occurrences in data, and improve data comparability, credibility, and defensibility. They should be sufficiently clear and written in a step-by-step format to be readily understood by a person knowledgeable in the general concept of the procedure.

---

<sup>4</sup> <http://www.gpoaccess.gov/cfr/index.html>

<sup>5</sup> [http://www.epa.gov/quality1/qa\\_docs.html](http://www.epa.gov/quality1/qa_docs.html)

Elements that may be included in SOPs which are explained in the guidance document *Guidance for the Preparation of Standard Operating Procedures EPA QA/G-6*<sup>6</sup> are:

1. Scope and Applicability
2. Summary of Method
3. Definitions
4. Health and Safety Warnings
5. Cautions
6. Interferences
7. Personnel Qualifications
8. Equipment and Supplies
9. Procedure (section may include all or part of these sections):
  - a. Instrument or Method Calibration
  - b. Sample Collection
  - c. Sample Handling and Preservation
  - d. Sample Preparation and Analysis
  - e. Troubleshooting
  - f. Data Acquisition, Calculations & Data Reduction
  - g. Computer Hardware & Software (used to manipulate analytical results and report data)
10. Data Management and Records Management Parameters
11. Quality Control/Quality Assurance

Elements that are not needed may be excluded or listed as “NA” (not applicable).

Personnel implementing SOPs may not be involved in the “larger picture” which includes the use of the data and whether or not DQOs are being achieved. Therefore, it’s very important that the SOP covers the objectives of the monitoring program and the importance of following each step in an SOP in order to achieve quality results.

**NOTE:** There may be some incentive to rely on vendor developed methods manuals or to reference analytical methods on internet sites (e.g., TO-15 for NATTS VOCs) as a monitoring organization’s SOP without revision. Although the majority of information in these documents may be appropriate, many times the methods provide more than one option for method implementation and is not specific to the organization implementing the method. Therefore, organizations are encouraged to utilize these methods but edit them to make them specific to the organization.

Many of these operational procedures listed above are included in the EPA reference and equivalent methods, and EPA guidance documents. However, it is the organization’s responsibility to develop its own unique written operational procedures applicable to air quality measurements made by the organization.

SOPs should be written by individuals performing the procedures that are being standardized. SOPs for the Ambient Air Quality Monitoring Program environmental data operations must be included in QAPPs, either by reference or by inclusion of the actual method. If a method is referenced, it should be stated that the method is followed exactly or an addendum that explains changes to the method should be included in the QAPP (see NOTE above). If a modified method will be used for an extended period of time, the

---

<sup>6</sup> <http://www.epa.gov/earth1r6/6pd/qa/qadevtools/mod4references/secondaryguidance/g6-final.pdf>

method should be revised to include the changes to appropriate sections. In general, approval of SOPs occurs during the approval of the QAPP. Individuals with appropriate training and experience with the particular SOPs in the QAPP need to review the SOPs.

SOPs should have some level of documented approval by the monitoring organization and be reviewed/approved at some frequency. There should be some level of document control on SOPs so that personnel can quickly determine whether or not they are using the most current method. The document control information on the pages of this Handbook provide a good example. It is suggested that the monitoring organization create a “master” list of the current SOPs it uses and include some document control information to allow users to identify the appropriate SOPs.

#### Field and Laboratory Notebooks--

Recording of some field and laboratory data is necessary for ambient air monitoring. Section 11 provides some details of activities that can be recorded in these notebooks. A standardized format should be utilized to ensure that all necessary information is obtained. The format should be designed to clearly identify the parameters during the measurements, the date and time, location of the measurement station, and operating personnel. This information may determine the credibility of the data and should not be erased or altered. Recording of the data should be legible. If a manual record is kept, any error should be crossed out with a single line, and the correct value recorded above the crossed-out entry.

Electronic recording and storage of data is widely used. Electronic recording of the data allows for flagging and retention of additional information that is pertinent to day to day operations that could otherwise be lost with conventional systems. The same information as listed in the above paragraph should be recorded during routine quality checks. Some monitoring organizations like to electronically produce strip charts of data and/or supporting information. This data can be used to enhance and support the validity of the data.

It is recommended a log book be kept for each instrument in a monitoring organization’s network. The information contained in this log should consist of the above information as well as any calibration, audit, and maintenance work performed on the instrument. This log should follow the instrument from site to site as the instrument may be moved. The date of any movement of the instrument should also be recorded in the log. This log can either be an electronic record or a hardbound book.

Additionally, a site log can be kept documenting maintenance of a specific monitoring site and the auxiliary monitoring equipment located there. Information that could be recorded includes maintenance to station HVAC system, air conditioner cleaning, maintenance to external sample intake pumps, permeation tube changes, sample line replacement or cleaning, and replacement of any equipment associated with the shelter or monitoring system. This log can also be either electronic or a hard bound book. Keeping this log can alert a field technician to upcoming maintenance as well as serve as a tool in determining data quality as necessary.

Do not discard original field records; copies of them are not normally admissible as evidence. For neatness, the field data may be transcribed or copied for incorporation in a final report, but the originals should be kept on file. Since these records may be subpoenaed, it is important that all field notes be legible.

## 5.4 Raw Data

Raw data includes any original factual information from a measurement activity or study recorded in laboratory work sheets, records, memoranda, notes, computer (electronic) files or exact copies thereof and that are necessary for the reconstruction and evaluation of the report of the activity or study. Raw data may include photographs, microfilm or microfiche copies, computer printouts, magnetic media, including dictated observations, and recorded data from automated instruments. For automated information systems, raw data is considered the original observations recorded by the information system that are needed to verify, calculate, or derive data that are or may be reported. Organizations should critically review the Ambient Air Quality Monitoring Program and create a list of what the organization considers raw data and provide a means to store this information in a manner that is readily accessible.

## 5.5 Data Reporting

In addition to samples and field records, the report of the analysis itself may serve as material evidence. Just as the procedures and data leading up to the final report are subject to the rules of evidence, so is the report. Written documents are generally considered as hearsay and are not admissible as evidence without a proper foundation. A proper foundation consists of introducing testimony from all persons having anything to do with the major portions of the measurement and analysis. Thus, the field operator, all persons having custody of the samples and data, and the analyst would be required to lay the foundation for the introduction of the measurement as evidence. This evidence can and should be recorded in the form of initials and notes written in indelible ink at the time of data collection on paper that is kept on file. The proper foundation is laid and available in case the data are questioned. Examples of this include strip charts dated and initialed by operator when visiting the site for routine quality checks and initials on routine paperwork and in logbooks when events are recorded. Electronic records should also allow for a recording of initials or be traceable to the operator performing the work.

To ensure compliance with legal rules, all measurement reports should be filed in a safe place by a custodian having this responsibility. Although the field notes and calculations are not generally included in the summary report, these materials may be required at a future date to bolster the acceptability and credibility of the report as evidence in an enforcement proceeding. Therefore, the full report including all original notes and calculation sheets should be kept in the file. Signed receipts for all samples, strip charts, or other data, should also be filed.

The original of a document is the best evidence; a copy is not normally admissible as evidence. Microfilm, snap-out carbon copies, and similar contemporary business methods of producing copies are acceptable in many jurisdictions if the unavailability of the original is adequately explained and if the copy was made in the ordinary course of business.

In summary, although all original calculations and measurement data need not be included in the final report, they should be kept in the agency's files. It is a good rule to file all reports together in a secure place. Keeping these documents under lock and key will ensure that the author can testify at future court hearings that the report has not been altered.

## 5.6 Data Management

Much of the data collected for the Ambient Air Quality Monitoring Program will be collected through the use of automated systems. These systems must be effectively managed and documented by using a set of guidelines and principles by which adherence will ensure data integrity. Discussions of data management activities and the requirements for documentation can be found in Section 14.

## 5.7 Quality Assurance

Quality assurance information is necessary to document the quality of data. A monitoring organization's plan for all quality assurance activities must be documented in its QAPP. This information should be retained in a manner that it can be associated with the routine data that it represents. QA information includes:

- **Control charts** - Use of control charts is explained in Section 12.
- **Data quality assessments (DQAs)** - These assessments are a statistical and scientific evaluation of the data set to determine the validity and performance of the data collection design and to determine the adequacy of the data set for its intended use. More discussion on DQAs can be found in Section 18.
- **QA Reports** - Reports pertaining to the quality of data are discussed in Sections 3 and 16.
- **Evaluation/Audits** - Assessments of various phases of the environmental data operation are discussed in Section 15.

## 6.0 Monitoring Network Design

The selection of a specific monitoring site includes four major activities:

1. Developing and understanding the monitoring objective and appropriate data quality objectives.
2. Identifying the spatial scale most appropriate for the monitoring objective of the site.
3. Identifying the general locations where the monitoring site should be placed.
4. Identifying specific monitoring sites.

This section describes the general concepts for establishing the SLAMS, NCore, STN, PAMS, and open path monitoring. Additional details can be found in 40 CFR Part 58, Appendix D<sup>1</sup> and the guidance information for the various monitor networks that can be found on AMTIC<sup>2</sup>.

As described in Section 1, air quality samples are generally collected for one or more of the following purposes:

- To provide air pollution data to the general public in a timely manner.
- To judge compliance with and/or progress made towards meeting ambient air quality standards.
- To activate emergency control procedures that prevent or alleviate air pollution episodes.
- To observe pollution trends throughout the region, including non-urban areas.
- To provide a data base for research evaluation of effects: urban, land-use, and transportation planning; development and evaluation of abatement strategies; and development and validation of diffusion models.

Network information related to these 5 purposes is discussed below.

### **“Real-Time” Air Quality Public Reporting**

The U.S. EPA, NOAA, NPS, tribal, state, and local agencies developed the AIRNow<sup>3</sup> Web site to provide the public with easy access to national air quality information. The Web site offers daily Air Quality Index (AQI):

**Conditions-** Nationwide and regional real-time ozone and PM<sub>2.5</sub> air quality maps covering 46 US States and parts of Canada. These maps are updated daily every hour. A click of a mouse brings up the U.S. map and a second click can bring up the AQI details of a region, state or local area within a state.

**Forecasts** - Nationwide daily air quality forecasts provided by monitoring organizations for over 300 major cities and areas in the U.S.

Federal requirements state that Metropolitan Statistical Areas (MSAs) with a population of more than 350,000 are required to report the AQI daily to the general public. The U.S. Office of Management and Budget defines MSAs according to the 2000 census. However, many other tribal, state and local monitoring organizations participate in AIRNow.

There are no specific network requirements or guidelines for reporting to AIRNow. Sites used for

---

<sup>1</sup> <http://www.epa.gov/ttn/amtic/40cfr53.html>

<sup>2</sup> <http://www.epa.gov/ttn/amtic/>

<sup>3</sup> <http://airnow.gov/>



reporting to AIRNow are sites that have been set up for the other monitoring objectives discussed above. The air quality data used in these maps and to generate forecasts are collected using either federal reference or equivalent monitoring techniques or techniques approved by the monitoring organizations. Since the information needed to make maps must be as "real-time" as possible, the data are displayed as soon as practical after the end of each hour. Although some preliminary data quality assessments are performed, the data as such are not fully verified and validated through the quality assurance procedures monitoring organizations use to officially submit and certify data on the EPA AQS. Therefore, data are used on the AIRNow Web site only for the purpose of reporting the AQI. Information on the AIRNow web site is not used to formulate or support regulation, guidance or any other Agency decision or position.

### **Compliance Monitoring**

The information required for selecting the number of samplers<sup>4</sup> and the sampler locations include isopleth maps, population density maps, and source locations. The following are suggested guidelines:

- the priority area is the zone of highest pollution concentration within the region; one or more stations should be located in this area;
- close attention should be given to densely populated areas within the region, especially when they are in the vicinity of heavy pollution;
- the quality of air entering the region is to be assessed by stations situated on the periphery of the region; meteorological factors (e.g., frequencies of wind directions) are of primary importance in locating these stations;
- sampling should be undertaken in areas of projected growth to determine the effects of future development on the environment;
- a major objective of compliance monitoring is the evaluation of progress made in attaining the desired air quality; for this purpose, sampling stations should be strategically situated to facilitate evaluation of the implemented control strategies; and
- some information of air quality should be available to represent all portions of the region of concern.

Some stations will be capable of fulfilling more than one of the functions indicated. For example, a station located in a densely populated area can indicate population exposures and can also document the changes in pollutant concentrations resulting from mitigation strategies used in the area.

### **Emergency Episode Monitoring**

For episode avoidance purposes, data are needed quickly--in no less than a few hours after the pollutant contacts the sensor. While it is possible to obtain data rapidly by on-site manual data reduction and telephone reporting, there is a trend towards using automated monitoring networks. The severity of the problem, the size of the receptor area, and the availability of resources all influence both the scope and sophistication of the monitoring system.

It is necessary to use continuous air samplers because of the short durations of episodes and the control actions taken must be based on real-time measurements that are correlated with the decision criteria. Based on episode alert criteria and mechanisms now in use, 1-h averaging times are adequate for

---

<sup>4</sup> A "sampler" in this context refers to both continuous instruments that provide an ambient air concentration without additional preparation or analytical techniques as well as instruments that provide a sample needing additional analysis.

surveillance of episode conditions. Shorter averaging times provide information on data collecting excursions, but they increase the need for automation because of the bulk of data obtained. Longer averaging times (>6 hours) are not desirable because of the delay in response that these impose. After an alert is announced, data are needed quickly so that requests for information on the event can be provided.

Collection and analysis must be accomplished rapidly if the data are to be useful immediately. Collection instruments must be fully operable at the onset of an episode. For the instrument to be maintained in peak operating condition, either personnel must be stationed at the sites during an episode or automated equipment must be operated that can provide automatic data transmission to a central location.

Monitoring sites should be located in areas where human health and welfare are most threatened:

- in densely populated areas;
- near large stationary source of pollution;
- near hospitals;
- near high density traffic areas; and
- near homes for the aged.

A network of sites is useful in determining the range of pollutant concentrations within the area, but the most desirable monitoring sites are not necessarily the most convenient. Public buildings such as schools, firehouses, police stations, hospitals, and water or sewage plants should be considered for reasons of access, security and existing communications.

### **Trends Monitoring**

Trends monitoring is characterized by locating a minimal number of monitoring sites across as large an area as possible while still meeting the monitoring objectives. The program objective is to determine the extent and nature of the air pollution and to determine the variations in the measured levels of the atmospheric contaminants in respect to the geographical, socio-economic, climatological and other factors. The data are useful in planning epidemiological investigations and in providing the background against which more intensive regional and community studies of air pollution can be conducted.

Urban sampling stations are usually located in the most densely populated areas of the region. In most regions, there are several urban sites. Non-urban stations encompass various topographical categories such as farmland, desert, forest, mountain and coast. Non-urban stations are not selected specifically to be "clean air" control sites for urban areas, but they do provide a relative comparison between some urban and nearby non-urban areas.

In interpreting trends data, limitations imposed by the network design must be considered. Even though precautions are taken to ensure that each sampling site is as representative as possible of the designated area, it is impossible to be certain that measurements obtained at a specific site are not unduly influenced by local factors. Such factors can include topography, structures, sources of pollution in the immediate vicinity of the site, and other variables; the effects which cannot always be accurately anticipated, but nevertheless, should be considered in network design. Comparisons among pollution levels for various areas are valid only if the sites are representative of the conditions for which the study is designed.

## **Research Monitoring**

Air monitoring networks related to health effects are composed of integrating samplers both for determining pollutant concentrations for  $\leq 24$  hours and for developing long term ( $\geq 24$  hour) ambient air quality standards. The research requires that monitoring points be located so that the resulting data will represent the population group under evaluation. Therefore, the monitoring stations are established in the centers of small well-defined residential areas within a community. Data correlations are made between observed health effects and observed air quality exposures.

Requirements for aerometric monitoring in support of health studies are as follows:

- the station must be located in or near the population under study;
- pollutant sampling averaging times must be sufficiently short to allow for use in acute health effect studies that form the scientific basis for short-term standards;
- sampling frequency, usually daily, should be sufficient to characterize air quality as a function of time; and
- the monitoring system should be flexible and responsive to emergency conditions with data available on short notice.

### **6.1 Monitoring Objectives and Spatial Scales**

With the end use of the air quality samples as a prime consideration, the national ambient air monitoring networks are designed to determine one of six basic monitoring objectives listed below:

1. Determine the highest concentration expected to occur in the area covered by the network.
2. Measure typical concentrations in areas of high population density.
3. Determine the impact of significant sources or source categories on air quality.
4. Determine background concentration levels.
5. Determine the extent of regional pollutant transport among populated areas; and in support of secondary standards.
6. Measure air pollution impacts on visibility, vegetation damage, or welfare-based impacts.

These six objectives indicate the nature of the samples that the monitoring network will collect that must be representative of the spatial area being studied. In the case of PAMS, the design criteria are site specific and, therefore, there are specific monitoring objectives associated with each location for which PAMS stations are required (see Table 6-4).

Sampling equipment requirements are generally divided into three categories, consistent with the desired averaging times:

1. **Continuous**- Pollutant concentrations determined with automated methods, and recorded or displayed continuously.
2. **Integrated**- Pollutant concentrations determined with manual or automated methods from integrated hourly or daily samples on a fixed schedule (i.e., manual  $PM_{2.5}$ ).
3. **Static**- Pollutant estimates or effects determined from long-term (weekly or monthly) exposure to qualitative measurement devices or materials (i.e., passive monitoring<sup>5</sup>)

---

<sup>5</sup> <http://www.epa.gov/ttn/amtic/passive.html>

Air monitoring sites that use automated equipment to continually sample and analyze pollutant levels may be classified as primary. Primary monitoring stations are generally located in areas where pollutant concentrations are expected to be among the highest and in areas with the highest population densities; thus, they are often used in health effects research networks. These stations are also designed as part of the air pollution episode warning system and used to report data to the public through AIRNow<sup>6</sup> and the air quality index (AQI).

The goal in siting stations is to correctly match the spatial scale represented by the sample of monitored air with the spatial scale most appropriate for the monitoring objective of the station. This achieves the goal of data quality indicator representativeness discussed in Section 3. The representative measurement scales of greatest interest are shown below:

<b>Micro</b>	Concentrations in air volumes associated with area dimensions ranging from several meters up to about 100 meters.
<b>Middle</b>	Concentrations typical of areas up to several city blocks in size with dimensions ranging from about 100 meters to 0.5 kilometer.
<b>Neighborhood</b>	Concentrations within some extended area of the city that has relatively uniform land use with dimensions in the 0.5 to 4.0 kilometers range.
<b>Urban</b>	Overall, citywide conditions with dimensions on the order of 4 to 50 kilometers. This scale would usually require more than one site for definition.
<b>Regional</b>	Usually a rural area of reasonably homogeneous geography and extends from tens to hundreds of kilometers.
<b>National/Global</b>	Concentrations characterizing the nation and the globe as a whole.

Table 6-1 illustrates the relationships among the four basic monitoring objectives and the scales of representativeness that are generally most appropriate for that objective. Appendix E provides more detailed spatial characteristics for each pollutant while Table 6-2 provides a summary for the various monitoring programs.

**Table 6-1 Relationship Among Monitoring Objectives and Scales of Representativeness**

<b>Monitoring Objective</b>	<b>Appropriate Siting Scale</b>
Highest Concentration	Micro, middle, neighborhood, sometimes urban
Population	Neighborhood, urban
Source impact	Micro, middle, neighborhood
General/background & Regional Transport	Urban/regional
Welfare-related	Urban/regional

There is the potential for using open path monitoring for microscale spatial scales. For microscale areas, however, siting of open path analyzers must reflect proper regard for the specific monitoring objectives. Specifically, the path-averaging nature of open path analyzers could result in underestimations of high pollutant concentrations at specific points within the measurement path for other ambient air monitoring situations. In open path monitoring, monitoring path lengths must be commensurate with the intended scale of representativeness and located carefully with respect to local sources or potential obstructions. For short-term/high-concentration or source-oriented monitoring, the monitoring path may need to be further restricted in length and be oriented perpendicular to the wind direction(s) determined by air quality modeling leading to the highest concentration, if possible. Alternatively, multiple paths may be used advantageously to obtain both wider area coverage and peak concentration sensitivity.

<sup>6</sup> <http://airnow.gov/>

**Table 6-2 Summary of Spatial Scales for SLAMS, NCore, PAMS, and Open Path (OP) Sites**

Spatial Scale	SLAMS Sites <sup>1</sup>							PM <sub>10-2.5</sub>	NCore	STN	NATTs	PAMS	OP
	SO <sub>2</sub>	CO	O <sub>3</sub>	NO <sub>2</sub>	Pb	PM <sub>10</sub>	PM <sub>2.5</sub>						
Micro	*	*			*	*	*	*					
Middle	*	*		*	*	*	*	*					*
Neighborhood	*		*	*	*	*	*	*	*	*	*	*	*
Urban			*	*	*		*		*	*	*	*	*
Regional			*		*		*		*		*		*

<sup>1</sup> SLAMS Site scales based on current listing in 40 CFR Part 58, Appendix D and do not include NCore spatial scale objective.

### 6.1.1 Monitoring Boundaries

The NAAQS refer to several boundaries that are defined below. These definitions are derived from the U.S. Office of Management and Budget (OMB).

**Core-based Statistical Area (CBSA)** – is defined by the OMB as a statistical geographic entity consisting of the county or counties associated with at least one urbanized area/urban cluster of at least 10,000 population, plus adjacent counties having a high degree of social and economic integration.

**Metropolitan Statistical Area (MSA)** - a category of CBSA with populations greater than 50,000<sup>7</sup>.

**Micropolitan Statistical Area** - are a category of CBSA with populations between 10,000 and 50,000

**Combined Statistical Area (CSA)** - is defined by the OMB as a geographical area consisting of two or more adjacent Core Based Statistical Areas (CBSA) with employment interchange of at least 15 percent. Combination is automatic if the employment interchange is 25 percent and determined by local opinion if more than 15 but less than 25 percent<sup>8</sup>.

**New England city and town areas (NECTAs)** - are analogous to CBSAs and are similarly classified as either metropolitan NECTAs (corresponding to MSAs) or micropolitan NECTAs (corresponding to micropolitan statistical areas). The principal difference between a CBSA and a NECTA is that NECTAs use New England towns as building blocks instead of counties. In the New England region, towns are a much more important level of government than counties. Because of this, NECTAs are usually a much closer approximation to metropolitan areas in New England than MSAs

**Monitoring Planning Area (MPA)** - means a contiguous geographic area with established, well defined boundaries, such as a CBSA, county or State, having a common area that is used for planning monitoring locations for PM<sub>2.5</sub>. An MPA may cross State boundaries, such as the Philadelphia PA–NJ MSA, and be further subdivided into community monitoring zones. MPAs are generally oriented toward CBSAs or CSAs with populations greater than 200,000, but for convenience, those portions of a State that are not associated with CBSAs can be considered as a single MPA.

**Community Monitoring Zone (CMZ)** – means an optional averaging area with established, well defined boundaries, such as county or census block, within an MPA that has relatively uniform concentrations of annual PM<sub>2.5</sub> as defined by 40 CFR Part 50, Appendix N. Two or more community oriented SLAMS monitors within a CMZ that meet certain requirements as set forth in Appendix N may be averaged (spatial averaging) for making comparisons to the annual PM<sub>2.5</sub> NAAQS.

<sup>7</sup> <http://www.census.gov/population/estimates/metro-city/List1.txt>

<sup>8</sup> <http://www.census.gov/population/estimates/metro-city/List6.txt>

## 6.2 Monitoring Site Location

Four criteria should be considered, either singly or in combination when locating sites, depending on the sampling objective. Orient the monitoring sites to measure the following:

1. Impacts of known pollutant emission categories on air quality.
2. Population density relative to receptor-dose levels, both short and long term.
3. Impacts of known pollutant emission sources (area and point) on air quality.
4. Representative area-wide air quality.

To select locations according to these criteria, it is necessary to have detailed information on the location of emission sources, geographical variability of ambient pollutant concentrations, meteorological conditions and population density. Therefore, selection of the number, locations and types of sampling stations is a complex process. The variability of sources and their intensities of emissions, terrains, meteorological conditions and demographic features require that each network be developed individually. Thus, selection of the network will be based upon the best available evidence and on the experience of the decision team.

The sampling site selection process involves considerations of the following factors:

**Economics** - The amount of resources required for the entire data collection activity, including operators, instrumentation, installation, safety equipment, maintenance, data retrieval/data transfer, data analysis, quality assurance and data interpretation.

**Security** - Experience has shown that in some cases, a particular site may not be appropriate for the establishment of an ambient monitoring station simply due to problems with the security of the equipment in a certain area. If the problems cannot be remedied via the use of standard security measures such as lighting, fences, etc., then attempts should be made to locate the site as near to the identified sector as possible while maintaining adequate security.

**Logistics** - Logistics is the process of dealing with the procurement, maintenance and transportation of material and personnel for a monitoring operation. This process requires the full knowledge of all aspects of the data collection operation including:

<i>Planning</i>	<i>Staffing</i>
<i>Reconnaissance</i>	<i>Procurement of goods and services</i>
<i>Training</i>	<i>Communications</i>
<i>Scheduling</i>	<i>Inventory</i>
<i>Safety</i>	

**Atmospheric considerations** - Atmospheric considerations may include the spatial and temporal variability of the pollutants and its transport to the monitoring site. Effects of buildings, terrain, and heat sources or sinks on the air trajectories can produce local anomalies of excessive pollutant concentrations. Meteorology must be considered in determining not only the geographical location of a monitoring site but also such factors as height, direction, and extension of sampling probes. The following meteorological factors can greatly influence the dispersal of pollutants:

**Wind speed** affects the travel time from the pollutant source to the receptor and the dilution of polluted air in the downwind direction. The concentrations of air pollutants are inversely proportional to the wind speed.

**Wind direction** influences the general movements of pollutants in the atmosphere. Review of available data can indicate mean wind direction in the vicinity of the major sources of emissions.

**Wind variability** refers to the random motions in both horizontal and vertical velocity components of the wind. These random motions can be considered atmospheric turbulence, which is either mechanical (caused by structures and changes in terrain) or thermal (caused by heating and cooling of land masses or bodies of water). If the scale of turbulent motion is larger than the size of the pollutant plume, the turbulence will move the entire plume and cause looping and fanning; if smaller, it will cause the plume to diffuse and spread out.

If the meteorological phenomena impact with some regularity, data may need to be interpreted in light of these atmospheric conditions. Other meteorological conditions to consider are atmospheric stability and lapse rate (the decrease of an atmospheric variable with height).

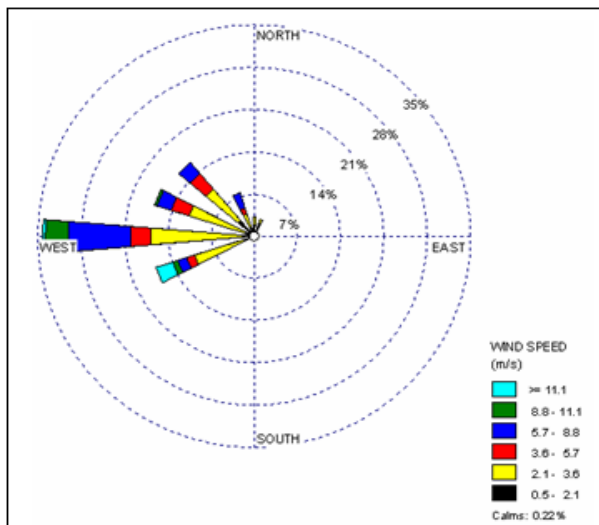

Figure 6.1 Wind rose pattern

A useful way of displaying wind data is a wind rose diagram constructed to show the distribution of wind speeds and directions. The wind rose diagram shown in Figure 6.1 represents conditions as they converge on the center from each direction of the compass. More detailed guidance for meteorological considerations is available<sup>9</sup>. Relevant weather information, such as stability-wind roses, is usually available from local National Weather Service stations. For PAMS monitoring, in many areas there are three types of high ozone days: overwhelming transport, weak transport (or mixed transport and stagnation) and stagnation. The wind rose concept to site monitors is only applicable to the transport types, but not applicable to the stagnation type. In general, transport types dominate north of 40° N, stagnation types dominate the Ohio River Valley and northern Gulf Coast, and

a mixture of the two is observed in the rest of the eastern United States. In areas where stagnation dominates the high ozone days, a well-defined primary wind direction (PWD) may not be available. If no well-defined PWD can be resolved, the major axes of the emissions sources should be used as substitutes for the PWDs and the PAMS monitors should be located along these axes.

Meteorological conditions, particularly those that can affect light transmission, should also be considered in selecting the location for open path analyzers (e.g., the influence of relative humidity on the creation of fog, the percentage of heavy snow, and the possible formation of haze, etc.). The percent fog, percent snow fall, percent haze, and hourly visibility (from nearest airport) may impact data completeness. Although sites with high relative humidity may have data capture rates around 90 percent, sites with relative humidity greater than 80 percent more than 20 percent of the time should be carefully assessed

<sup>9</sup> QA Handbook for Meteorological Measurements Volume IV <http://www.epa.gov/ttn/amtic/met.html>

for data completeness, or avoided. Similarly, severe fog, snow fall, or haze that affects visibility can affect data completeness and should be kept to less than 20 percent of the time. The time of day or season when such conditions occur should also be determined to ensure that representative data from various time periods and seasons are collected. No more than 20 percent of data in any time period should be lost as a result of the aforementioned meteorological conditions. Sometimes, high data capture at locations with frequent fog or other obscurant conditions can be enhanced by using a shorter path length of 50 to 100 meters. However, this can be done only for microscale sites. Meteorological data considerations therefore should include the following measurements: (1) hourly precipitation amounts for climatological comparisons, (2) hourly relative humidity, (3) percent haze, and (4) airport visibility.

**Topography** - Both the transport and the diffusion of air pollutants are complicated by topographical features. Minor topographical features may exert small influences; major features, such as deep river valleys or mountain ranges, may affect large areas. Before final site selection, review the topography of the area to ensure that the purpose of monitoring at that site will not be adversely affected. Table 6-3 summarizes important topographical features, their effects on air flow, and some examples of influences on monitoring site selection. Land use and topographical characterization of specific areas can be determined from U.S. Geological Survey (USGS) maps as well as from land use maps.

**Table 6-3 Relationships of Topography, Air Flow, and Monitoring Site Selection**

Topographical feature	Influence on air flow	Influence on monitoring site selection
Slope/Valley	Downward air currents at night and on cold days; up slope winds on clear days when valley heating occurs. Slope winds and valley channeled winds; tendency toward down-slope and down-valley winds; tendency toward inversions	Slopes and valleys as special sites for air monitors because pollutants generally are well dispersed; concentration levels not representative of other geographic areas; possible placement of monitor to determine concentration levels in a population or industrial center in valley
Water	Sea or lake breezes inland or parallel to shoreline during the day or in cold weather; land breezes at night.	Monitors on shorelines generally for background readings or for obtaining pollution data on water traffic
Hill	Sharp ridges causing turbulence; air flow around obstructions during stable conditions, but over obstructions during unstable conditions	Depends on source orientation; upwind source emissions generally mixed down the slope, and siting at foot of hill not generally advantageous; downwind source emissions generally down washed near the source; monitoring close to a source generally desirable if population centers adjacent or if monitoring protects workers
Natural or manmade obstruction	Eddy effects	Placement near obstructions not generally representative in readings

**Pollutant Considerations** - A sampling site or an array of sites for one pollutant may be appropriate for another pollutant species because of the configuration of sources, the local meteorology, or the terrain. Pollutants undergo changes in their compositions between their emission and their detection; therefore, the impact of that change on the measuring system should be considered. Atmospheric chemical reactions such as the production of O<sub>3</sub> in the presence of NO<sub>x</sub> and hydrocarbons (HCs) and the time delay between the emission of NO<sub>x</sub> and HCs and the detection peak of O<sub>3</sub> values may require either a sampling network for the precursors of O<sub>3</sub> and/or a different network for the actual O<sub>3</sub> measurement.

The success of the PAMS monitoring program is predicated on the fact that no site is unduly influenced by any one stationary emissions source or small group of emissions sources. Any significant influences would cause the ambient levels measured by that particular site to mimic the emissions rates of this source or sources rather than following the changes in nonattainment area-wide emissions as intended by the Rule. For purposes of this screening procedure, if more than 10% of the typical "lower end"



concentration measured in an urban area is due to a nearby source of precursor emissions, then the PAMS site should be relocated or a more refined analysis conducted than is presented here. Detailed procedures can be found in the *PAMS Implementation Manual*<sup>10</sup>.

None of the factors mentioned above stand alone. Each is dependent in part on the others. However, the objective of the sampling program must be clearly defined before the selection process can be initiated, and the initial definition of priorities may have to be reevaluated after consideration of the remaining factors before the final site selection. While the interactions of the factors are complex, the site selection problems can be resolved. Experience in the operation of air quality measurement systems; estimates of air quality, field and theoretical studies of air diffusion; and considerations of atmospheric chemistry and air pollution effects make up the required expertise needed to select the optimum sampling site for obtaining data representative of the monitoring objectives.

### 6.2.1 PAMS Site Descriptions

The PAMS network array for an area should be fashioned to supply measurements that will assist States in understanding and solving ozone nonattainment problems. Table 6-4 describes the five site types identified in the PAMS network. In 2007, EPA determined that the number of required PAMS sites could be reduced. Only one Type 2 site is required per area regardless of population; Type 4 sites would not be required; and only one Type 1 or one Type 3 site would be required per area.

**Table 6-4 Site Descriptions of PAMS Monitoring Sites**

Type #	Meas. Scale	Description
1	Urban	<b>Upwind and background characterization</b> to identify those areas which are subjected to overwhelming incoming transport of ozone. The #1 Sites are located in the predominant morning upwind direction from the local area of maximum precursor emissions and at a distance sufficient to obtain urban scale measurements. Typically, these sites will be located near the upwind edge of the photochemical grid model domain.
2	Neighborhood	<b>Maximum ozone precursor emissions impacts</b> located immediately downwind (using the same morning wind direction as for locating Site #1) of the area of maximum precursor emissions and are typically placed near the downwind boundary of the central business district (CBD) or primary area of precursor emissions mix to obtain neighborhood scale measurements.
2a	Neighborhood	<b>Maximum ozone precursor emissions impacts -second-most predominant morning wind direction</b>
3	Urban	<b>Maximum ozone concentrations</b> occurring downwind from the area of maximum precursor emissions. Locations for #3 Sites should be chosen so that urban scale measurements are obtained. Typically, these sites are located 10 to 30 miles from the fringe of the urban area
4	Urban	<b>Extreme downwind monitoring</b> of transported ozone and its precursor concentrations exiting the area and will identify those areas which are potentially contributing to overwhelming ozone transport into other areas. The #4 Sites are located in the predominant afternoon downwind direction from the local area of maximum precursor emissions at a distance sufficient to obtain urban scale measurements. Typically, these sites will be located near the downwind edge of the photochemical grid model domain.

There are three fundamental criteria to consider when locating a final PAMS site: sector analysis, distance, and proximate sources. These three criteria are considered carefully by EPA when approving or disapproving a candidate site for PAMS.

<sup>10</sup> <http://www.epa.gov/ttn/amtic/pams.html>

### 6.3 Monitor Placement

Final placement of the monitor at a selected site depends on physical obstructions and activities in the immediate area, accessibility/availability of utilities and other support facilities in correlation with the defined purpose of the specific monitor and its design. Because obstructions such as trees and fences can significantly alter the air flow, monitors should be placed away from obstructions. It is important for air flow around the monitor to be representative of the general air flow in the area to prevent sampling bias. Detailed information on urban physiography (e.g., buildings, street dimensions) can be determined through visual observations, aerial photography and surveys. Such information can be important in determining the exact locations of pollutant sources in and around the prospective monitoring site areas.

Network designers should avoid sampling locations that are unduly influenced by down wash or ground dust (e.g., a rooftop air inlet near a stack or a ground-level inlet near an unpaved road); in these cases, the sample intake should either be elevated above the level of the maximum ground turbulence effect or placed at a reasonable distance from the source of ground dust.

Depending on the defined monitoring objective, the monitors are placed according to exposure to pollution. Due to the various physical and meteorological constraints discussed above, tradeoffs will be made to locate a site in order to optimize representativeness of sample collection. The consideration should include categorization of sites relative to their local placements. Suggested categories relating to sample site placement for measuring a corresponding pollution impact are identified in Table 6-5.

**Table 6-5 Monitoring Station Categories Relating to Sample Site Placement**

Station Category	Characterization
A (ground level)	Heavy pollutant concentrations, high potential for pollutant buildup. A site 3 to 5 m (10-16 ft) from major traffic artery and that has local terrain features restricting ventilation. A sampler probe that is 3 to 6 m (10-20 ft) above ground.
B (ground level)	Heavy pollutant concentrations, minimal potential for a pollutant buildup. A site 3 to 15 m (15-50 ft) from a major traffic artery, with good natural ventilation. A sampler probe that is 3 to 6 m (10-20 ft) above ground.
C (ground level)	Moderate pollutant concentrations. A site 15 to 60 m (5-200 ft) from a major traffic artery. A sampler probe that is 3 to 6 m (10-20 ft) above ground.
D (ground level)	Low pollutant concentrations. A site $60 \geq m (\geq 200 \text{ ft})$ for a traffic artery. A sampler probe that is 3 to 6 m (10-20 ft) above ground.
E (air mass)	Sampler probe that is between 6 and 45 m (20-150 ft) above ground. Two subclasses: (1) good exposure from all sides (e.g., on top of building) or (2) directionally biased exposure (probe extended from window).
F (source-oriented)	A sampler that is adjacent to a point source. Monitoring that yields data directly relatable to the emission source.

### 6.4 Minimum Network Requirements

In 2007, the minimum network site requirements for the criteria pollutants CO, NO<sub>2</sub> and SO<sub>2</sub> were removed. Where SLAMS monitoring for these three criteria pollutants are ongoing, at least one site must be a maximum concentration sites for that area under investigation. Rather than place tables for minimum monitoring site requirements in the Handbook (since they have a tendency to change), the reader is directed to 40 CFR Part 58, Appendix D<sup>11</sup> of the most current regulation to find the appropriate minimum monitoring network requirements.

<sup>11</sup> <http://www.gpoaccess.gov/cfr/index.html> or <http://www.epa.gov/ttn/amtic/40cfr53.html>

## 6.5 Operating Schedules

**NOTE: The reader should check the most current version of 40 CFR Part 58 to ensure the schedules below have not changed.**

**For continuous analyzers**, consecutive hourly averages must be collected except during:

1. periods of routine maintenance;
2. periods of instrument calibration; or
3. periods or monitoring seasons exempted by the Regional Administrator.

**For Pb manual methods**, at least one 24-hour sample must be collected every 6 days except during periods or seasons exempted by the Regional Administrator.

**For PAMS VOC samplers**, samples must be collected as specified in 40 CFR Part 58, Appendix D Section 5. Area specific PAMS operating schedules must be included as part of the PAMS network description and must be approved by the Regional Administrator.

**For manual PM<sub>2.5</sub> samplers:**

1. **Manual PM<sub>2.5</sub> samplers at SLAMS stations** other than NCore stations must operate on at least a 1-in-3 day schedule at sites without a collocated continuously operating PM<sub>2.5</sub> monitor. For SLAMS PM<sub>2.5</sub> sites with both manual and continuous PM<sub>2.5</sub> monitors operating, the monitoring agency may request approval for a reduction to 1-in-6 day PM<sub>2.5</sub> sampling at SLAMS stations or for seasonal sampling from the EPA Regional Administrator. The EPA Regional Administrator may grant sampling frequency reductions after consideration of factors, including but not limited to the historical PM<sub>2.5</sub> data quality assessments, the location of current PM<sub>2.5</sub> design value sites, and their regulatory data needs. Sites that have design values that are within plus or minus 10 percent of the NAAQS; and sites where the 24-hour values exceed the NAAQS for a period of 3 years are required to maintain at least a 1-in-3 day sampling frequency. Sites that have a design value within plus or minus 5 percent of the daily PM<sub>2.5</sub> NAAQS must have an FRM or FEM operate on a daily schedule. The national sampling schedule can be found on AMTIC<sup>12</sup>.
2. **Manual PM<sub>2.5</sub> samplers at NCore stations** and required regional background and regional transport sites must operate on at least a 1-in-3 day sampling frequency.
3. **Manual PM<sub>2.5</sub> speciation samplers at STN stations** must operate on a 1-in-3 day sampling frequency.

**For PM<sub>10</sub> samplers**, a 24-hour sample must be taken from midnight to midnight (local time) to ensure national consistency. The minimum monitoring schedule for the site in the area of expected maximum concentration shall be based on the relative level of that monitoring site concentration with respect to the 24-hour standard as illustrated in Figure 6.2. If the operating agency demonstrates by monitoring data that during certain periods of the year conditions preclude violation of the PM<sub>10</sub> 24-hour standard, the increased sampling frequency for those periods or seasons may be exempted by the Regional Administrator and permitted to revert back to once in six days. The minimum sampling schedule for all other sites in the area remains once every six days.

---

<sup>12</sup> <http://www.epa.gov/ttn/amtic/calendar.html>

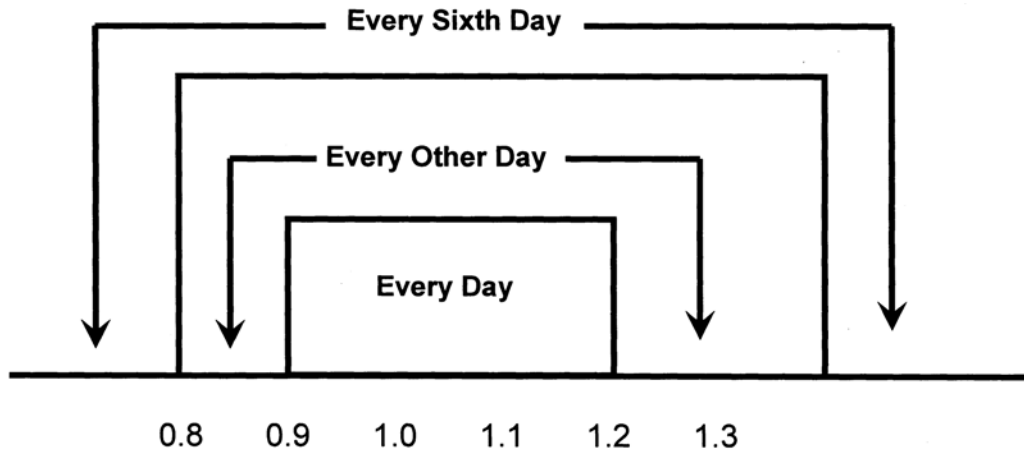

Figure 6.2 Sampling schedule based on ratio to the 24-hour PM<sub>10</sub> NAAQS

**For manual PM<sub>10-2.5</sub> samplers:**

1. **Manual PM<sub>10-2.5</sub> samplers at NCore stations** must operate on at least a 1-in-3 day schedule at sites without a collocated continuously operating federal equivalent PM<sub>10-2.5</sub> method that has been designated in accordance with 40 CFR Part 53.
2. **Manual PM<sub>10-2.5</sub> speciation samplers** at NCore stations must operate on at least a 1-in-3 day sampling frequency.

**For NATTS Monitoring,** samplers must operate year round and follow the national 1-in-6 day sampling schedule.

**6.5.1 Operating Schedule Completeness**

Data required for comparison to the NAAQS have specific completeness requirements. These completeness requirements generally start from completeness at hourly and 24-hour concentration values. However, the data used for NAAQS determinations include 3-hour, 8-hour, quarterly, annual and multiple year levels of data aggregation. Generally, depending on the calculation of the design value, EPA requires data to be 75% complete. All continuous measurements come down to what is considered a valid hour and currently all 24-hour estimates based on sampling (manual PM, Pb, TSP) are based on a 24-hour sampling period. Table 6-6 provides the completeness goals for the various ambient air program monitoring programs.

The data cells highlighted in Table 6-6 refer to the standards that apply to the specific pollutant. Even though a highlighted cell lists the completeness requirement, CFR provides additional detail, in some cases, on how a design value might be calculated with less data than the stated requirement. Therefore, the information provided in Table 6-6 should be considered the initial completeness goal which should be attempted to be achieved. Completeness goals that are not highlighted, although not covered in CFR, are very important to the achievement of the CFR completeness goals. So, for example, even though there is only an 8-hour ozone standard, it's important to have complete 1-hour values in order to compare to the 8-hour standard.

**Table 6-6 Completeness Goals for Ambient Air Monitoring Data**

Pollutants	Completeness Goals and Associated Standards (highlighted)					
	1-hour	3-hour	8-hour	24-hour	Quarterly	Annual
CO	45, 1 min. values		75% of hourly values	75% of hourly values		75% of hourly values per quarter
O <sub>3</sub>	45, 1 min. values		75% of hourly values			
SO <sub>2</sub>	45, 1 min. values	All 3 hours 75% complete		75% of hourly values		75% of hourly values per quarter
NO <sub>2</sub>	45, 1 min. values					75% of hourly values per quarter
PM <sub>10</sub> Cont	45, 1 min. values			23 hours**		
PM <sub>2.5</sub> Cont.	45, 1 min. values			23 hours		
PM <sub>10</sub> Manual				23 Hours**		
PM <sub>2.5</sub> Manual				23 hours	75% of samples	
Pb				23 Hours	75% of samples**	
PAMS				23 Hours		
NATTS				23 Hours		
STN				23 Hours		

\*\* not defined in CFR

For continuous instruments, it is suggested that 45, 1-minute values be considered a valid hour. Therefore, it is expected that 1-minute concentration values would be archived for a period of time (see statute of limitations in Section 5). Since various QC checks take time to complete, (zero/span/1-point QC) it is suggested that they be implemented in a manner that spans two hours (e.g., at 11:45 PM to 12:15 AM) in order to avoid losing an hour's worth of data.

### 6.5.2 Monitoring Seasons

Most of the monitoring networks operate year round with the exception of PAMS and ozone monitoring.

**PAMS** - 40 CFR 58, Appendix D<sup>10</sup> stipulates that PAMS precursor monitoring must be conducted annually throughout the months of June, July and August (as a minimum) when peak O<sub>3</sub> values are expected in each area. Alternate precursor monitoring periods may be submitted for approval to the Administrator as a part of the annual monitoring network plan.

**Ozone** - Since O<sub>3</sub> levels decrease significantly in the colder parts of the year in many areas, O<sub>3</sub> is required to be monitored at SLAMS monitoring sites only during the "ozone season" as designated in the AQS files on a State-by-State basis and described in 40 CFR Part 58, Appendix D<sup>13</sup>. Deviations from the O<sub>3</sub> monitoring season must be approved by the EPA Regional Administrator, documented within the annual monitoring network plan, and updated in AQS.

<sup>13</sup> <http://www.gpoaccess.gov/cfr/index.html>

## 7.0 Sampling Methods

To establish the basic validity of ambient air monitoring data, it must be shown that:

- the proposed sampling method complies with the appropriate monitoring regulations;
- the equipment is accurately sited;
- the equipment was accurately calibrated using correct and established calibration methods; and
- the organization implementing the data collection operation are qualified and competent.

For example, if the only reasonable monitoring site has a less than ideal location, the data collection organization must decide whether a representative sample can be obtained at the site. This determination should be recorded and included in the program's QAPP. Although after-the-fact site analysis may suffice in some instances, good quality assurance techniques dictate that this analysis be made prior to expending the resources required to collect the data.

The purpose of this section is to describe the attributes of the sampling system that will ensure the collection of data of a quality acceptable for the Ambient Air Quality Monitoring Program.

### 7.1 Environmental Control

#### 7.1.1 Monitoring Station Design

State and local agencies should design their monitoring stations with the station operator in mind. Careful thought to safety, ease of access to instruments and optimal work space should be given every consideration. If the station operator has these issues addressed, then he/she will be able to perform their duties more efficiently and diligently. Having the instruments in an area that is difficult to work in creates frustration and prolongs downtime. The goal is to optimize data collection and quality. This must start with designing the shelter and laboratory around staff needs and requirements.

Monitoring stations may be located in urban areas where space and land are at a premium, especially in large cities that are monitoring for NO<sub>x</sub> and CO. In many cases, the monitoring station is located in a building or school that is gracious enough to allow an agency to locate its equipment. Sometimes, a storage or janitorial closet is all that is available. However, this can pose serious problems. If the equipment is located in a closet, then it is difficult for the agency to control the effects of temperature, humidity, light, vibration and chemicals on the instruments. In addition, security can also be an issue if people other than agency staff have access to the equipment. Monitoring organizations should give serious thought to locating air monitoring equipment in stand-alone shelters with limited access, or modify existing rooms to the recommended station design if funds and staff time are available.

In general, air monitoring stations should be designed for functionality and ease of access for operation, maintenance and repair. In addition, the shelter should be rugged enough to withstand local weather condition extremes. In the past, small utility trailers were the norm in monitoring shelters. However, in some areas, this will not suffice. Recently, steel and aluminum storage containers are gaining wide acceptance as monitoring shelters. It is recommended that monitoring stations be housed in shelters that are fairly secure from intrusion or vandalism. All sites should be located in fenced or secure areas with access only through locked gates or secure pathways. The shelter's design dictates that they be insulated (R-19 minimum) to prevent temperature extremes within the shelter. All structures should be secured to their foundations and protected from damage during natural disasters. All monitoring shelters should be

designed to control excessive vibrations and external light falling on the instruments, and provide 110/220 VAC voltage throughout the year. When designing a monitoring shelter, make sure that enough electrical circuits are secured for the current load of equipment plus other instruments that may be added later or audit equipment (e.g., NPAP/PEP). Every attempt should be made to reduce the environmental footprint of shelters to make them as energy efficient as possible. Some possibilities include venting of excess heat of monitoring instruments to the outside in summer months, use of energy efficient fixtures and HVAC systems, and ensuring that the amount of space devoted to the monitors is not excessive (remembering that space is needed at times for additional QA equipment). Figure 7.1 represents one shelter design that has proven adequate.

The first feature of the shelter is that there are two rooms separated by a door. The reasons for this are twofold. The entry and access should be into the computer/data review area. This allows access to the site without having to open the room that houses the equipment. It also isolates the equipment from cold/hot air that can come into the shelter when someone enters. Also, the Data Acquisition System (DAS)/data review area is isolated from the noise and vibration of the equipment. This area can be a place where the operator can print data, and prepare samples for the laboratory. This also gives the operator an area where cursory data review can take place. If something is observed during this initial review then possible problems can be corrected or investigated at that time. The DAS can be linked through cables that travel through conduit into the equipment area. The conduit is attached to the ceiling or walls and then dropped down to the instrument rack.

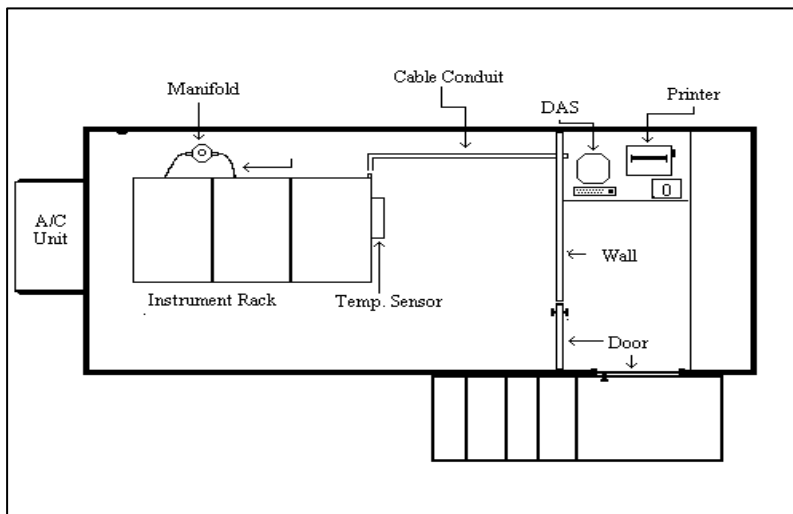

**Figure 7.1 Example Design for Shelter**

racks away from the wall, the rear of the instruments are accessible. The trays or rails allow the site operators access to the instruments without removing them from the racks. Most instrument vendors offer sliding rails as an optional purchase.

### 7.1.2 Sampling Environment

A proper sampling environment demands control of all physical parameters external to the samples that might affect sample stability, chemical reactions within the sampler, or the function of sampler components. The important parameters to be controlled are summarized in Table 7-1.

The air conditioning/heating unit should be mounted to heat and cool the equipment room. When specifying the unit, make sure it will cool the room on the warmest and heat on the coldest days of the year. Also, make sure the electrical circuits are able to carry the load. If necessary, keep the door closed between the computer and equipment room to lessen the load on the heating or cooling equipment.

All air quality instrumentation should be located in an instrument rack or equivalent. The instruments and their support equipment are placed on sliding trays or rails. By placing the

**Table 7-1 Environment Control Parameters**

Parameter	Source of specification	Method of Control
Instrument vibration	Manufacturer's specifications	Design of instrument housings, benches, etc., per manufacturer's specifications.
Light	Method description or manufacturer's specifications	Shield chemicals or instruments that can be affected by natural or artificial light
Electrical voltage	Method description or manufacturer's specifications	Constant voltage transformers or regulators; separate power lines; isolated high current drain equipment such as hi-vols, heating baths, pumps from regulated circuits
Temperature	Method description or manufacturer's specifications	Regulated air conditioning system 24-hour temperature recorder; use electric heating and cooling only
Humidity	Method description or manufacturer's specifications	Regulated air conditioning system; 24-hour temperature recorder

With respect to environmental temperature for designated analyzers, most such analyzers have been tested and qualified over a temperature range of 20°C to 30°C; few are qualified over a wider range. This temperature range specifies both the range of acceptable operating temperatures and the range of temperature change which the analyzer can accommodate without excessive drift. The latter, the range of temperature change that may occur between zero and span adjustments, is the most important. When one is outfitting a shelter with monitoring equipment, it is important to recognize and accommodate the instrument with the most sensitive temperature requirement.

To accommodate energy conservation regulations or guidelines specifying lower thermostat settings, designated analyzers located in facilities subject to these restrictions may be operated at temperatures down to 18°C, provided the analyzer temperature does not fluctuate by more than 10°C between zero and span adjustments. Operators should be alert to situations where environmental temperatures might fall below 18°C, such as during night hours or weekends. Temperatures below 18°C may necessitate additional temperature control equipment or rejection of the area as a sampling site.

Shelter temperatures above 30°C also occur, due to temperature control equipment that is malfunctioning, lack of adequate power capacity, or shelters of inadequate design for the environmental conditions. Occasional fluctuations above 30°C may require additional assurances that data quality is maintained. Sites that continually have problems maintaining adequate temperatures may necessitate additional temperature control equipment or rejection of the area as a sampling site. If this is not an option, a waiver to operate beyond the required temperature range should be sought with the EPA Regional Office, if it can be shown that the site can meet established data quality requirements.

In order to detect and correct temperature fluctuations, a 24-hour temperature recorder at the analyzer site is suggested. These recorders can be connected to data loggers and should be considered official documentation that should be filed (see Section 5). Many vendors offer these type of devices. Usually they are thermocouple/thermistor devices of simple design and are generally very sturdy. Reasons for using electronic shelter temperature devices are two-fold: 1) through remote interrogation of the DAS, the agency can tell if values collected by air quality instruments are valid, and 2) that the shelter temperature is within a safe operating range if the air conditioning/heating system fails.



## 7.2 Sampling Probes And Manifolds

### 7.2.1 Design of Probes and Manifolds for Automated Methods

Some important variables affecting the sampling manifold design are the diameter, length, flow rate, pressure drop, and materials of construction. With the development of NCore precursor gas monitoring, various types of probe/manifold designs were reviewed. This information can be found in the *Technical Assistance Document (TAD) for Precursor Gas Measurements in the NCore Multi-pollutant Monitoring Network*<sup>1</sup> and is also included in Appendix F of this Handbook.

Of the probe and manifold material looked at over the years, only Pyrex<sup>®</sup> glass and Teflon<sup>®</sup> have been found to be acceptable for use as intake sampling lines for all the reactive gaseous pollutants. Furthermore, the EPA has specified borosilicate glass or FEP Teflon<sup>®</sup> as the only acceptable probe materials for delivering test atmospheres in the determination of reference or equivalent methods. Therefore, borosilicate glass (which includes Pyrex<sup>®</sup>), FEP Teflon<sup>®</sup> or their equivalent must be the only material in the sampling train (from inlet probe to the back of the analyzer) that can be in contact with the ambient air sample for existing and new SLAMS.

For volatile organic compound (VOC) monitoring at PAMS, FEP Teflon<sup>®</sup> is unacceptable as the probe material because of VOC adsorption and desorption reactions on the FEP Teflon<sup>®</sup>. Borosilicate glass, stainless steel, or its equivalent, are the acceptable probe materials for VOC and carbonyl sampling. Care must be taken to ensure that the sample residence time is kept to 20 seconds or less.

#### Residence Time Determination

No matter how nonreactive the sampling probe material may be, after a period of use, reactive particulate matter is deposited on the probe walls. Therefore, the time it takes the gas to transfer from the probe inlet to the sampling device is also critical. Ozone, in the presence of nitrogen oxide (NO), will show significant losses even in the most inert probe material when the residence time exceeds 20 seconds. Other studies indicate that a 10-second or less residence time is easily achievable.

Residence time is defined as the amount of time that it takes for a sample of air to travel from the opening of the cane to the inlet of the instrument and is required to be less than 20 seconds for reactive gas monitors. The residence time of pollutants within the sampling manifold is also critical. It is recommended that the residence time within the manifold and sample lines to the instruments be less than 10 seconds (of the total allowable 20 seconds). If the volume of the manifold does not allow this to occur, then a blower motor or other device (vacuum pump) can be used to decrease the residence time. The residence time for a manifold system is determined in the following way. First the volume of the cane, manifold and sample lines must be determined using the following equation:

$$\text{Total Volume} = C_v + M_v + L_v$$

Where:

$C_v$  = Volume of the sample cane and extensions,  $\text{cm}^3$

$M_v$  = Volume of the sample manifold and trap,  $\text{cm}^3$

---

<sup>1</sup> <http://www.epa.gov/ttn/amtic/files/ambient/monitorstrat/precursor/tadversion4.pdf>

$L_v$  = Volume of the instrument lines,  $\text{cm}^3$

Each of the components of the sampling system must be measured individually. To measure the volume of the components, use the following calculation:

$$V = \pi i * (d/2)^2 * L$$

Where:

V = volume of the component,  $\text{cm}^3$

$\pi$  = 3.14159

L = Length of the component, cm

d = inside diameter, cm

Once the total volume is determined, divide the volume by the flow rate of all instruments. This will give the residence time.

It has been demonstrated that there are no significant losses of reactive gas ( $\text{O}_3$ ) concentrations in conventional 13 mm inside diameter sampling lines of glass or Teflon if the sample residence time is 10 seconds or less. This is true even in sample lines up to 38 m in length, which collect substantial amounts of visible contamination due to ambient aerosols. However, when the sample residence time exceeds 20 seconds, loss is detectable, and at 60 seconds the loss is nearly complete.

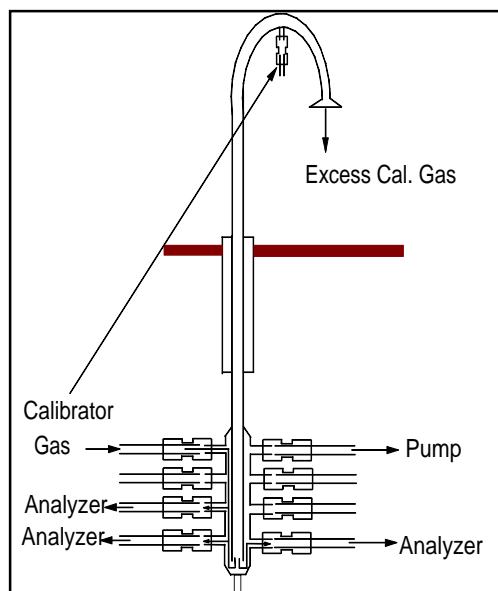

**Figure 7.2 Positions of calibration line in sampling manifold**

**Placement of tubing on the Manifold:** If the manifold that is employed at the station has multiple ports then placement of the instrument lines can be crucial. If a manifold similar to Figure 7.2 is used, it is suggested that instruments requiring lower flows be placed towards the bottom of the manifold. The general rule of thumb states that the calibration line (if used) placement should be in a location so that the calibration gases flow past the instruments before the gas is evacuated out of the manifold. Figure 7.2 illustrates two potential introduction ports for the calibration gas. The port at the elbow of the sampling cane provides more information about the cleanliness of the sampling system.

## 7.2.2 Placement of Probes and Manifolds

Probes and manifolds must be placed to avoid introducing bias to the sample. Important considerations are probe height above the ground, probe length (for horizontal probes), and physical influences near the probe.

Some general guidelines for probe and manifold placement are:

- probes should not be placed next to air outlets such as exhaust fan openings
- horizontal probes must extend beyond building overhangs
- probes should not be near physical obstructions such as chimneys which can affect the air flow in the vicinity of the probe
- height of the probe above the ground depends on the pollutant being measured

Table 7-2 summarizes the probe and monitoring path siting criteria while Table 7-3 summarizes the spacing of probes from roadways. This information can be found in 40 CFR Part 58, Appendix E<sup>2</sup>. For PM<sub>10</sub> and PM<sub>2.5</sub>, Figure 7.3 provides the acceptable areas for micro, middle, neighborhood and urban samplers, with the exception of microscale street canyon sites.

**Table 7-2 Summary of Probe and Monitoring Path Siting Criteria**

Pollutant	Scale (maximum monitoring path length, meters)	Height from ground to probe, inlet or 80% of monitoring path <sup>1</sup> (meters)	Horizontal and vertical distance from supporting structures <sup>2</sup> to probe, inlet or 90% of monitoring path <sup>1</sup> (meters)	Distance from trees to probe, inlet or 90% of monitoring path <sup>1</sup> (meters)	Distance from roadways to probe, inlet or monitoring path <sup>1</sup> (meters)
SO <sub>2</sub> <sup>3,4,5,6</sup>	Middle (300 m) Neighborhood Urban, and Regional (1 km).	2–15	> 1	> 10	N/A
CO <sup>4,5,7</sup>	Micro, Middle (300 m), Neighborhood (1 km).	3 ± 1/2: 2–15	> 1	> 10	2–10; see Table 7–3 of this section for middle and neighborhood scales.
NO <sub>2</sub> , O <sub>3</sub> <sup>3,4,5</sup>	Middle (300 m) Neighborhood, Urban, and Regional (1 km).	2–15	> 1	> 10	See Table 7-3 of this section for all scales.
Ozone precursors (for PAMS) <sup>3,4,5</sup>	Neighborhood and Urban (1 km)	2–15	> 1	> 10	
PM,Pb <sup>3,4,5,6,8</sup>	Micro: Middle, Neighborhood, Urban and Regional.	2–7 (micro); 2–7 (middle PM10-2.5); 2–15 (all other scales).	> 2 (all scales, horizontal distance only).	> 10 (all scales).	2–10 (micro); see Figure 7.3 of this section for all other scales

N/A—Not applicable.

<sup>1</sup> Monitoring path for open path analyzers is applicable only to middle or neighborhood scale CO monitoring and all applicable scales for monitoring SO<sub>2</sub>, O<sub>3</sub>, O<sub>3</sub> precursors, and NO<sub>2</sub>.

<sup>2</sup> When probe is located on a rooftop, this separation distance is in reference to walls, parapets, or penthouses located on roof.

<sup>3</sup> Should be >20 meters from the dripline of tree(s) and must be 10 meters from the dripline when the tree(s) act as an obstruction.

<sup>4</sup> Distance from sampler, probe, or 90% of monitoring path to obstacle, such as a building, must be at least twice the height the obstacle protrudes above the sampler, probe, or monitoring path. Sites not meeting this criterion may be classified as middle scale (see text).

<sup>5</sup> Must have unrestricted airflow 270 degrees around the probe or sampler; 180 degrees if the probe is on the side of a building.

<sup>6</sup> The probe, sampler, or monitoring path should be away from minor sources, such as furnace or incineration flues. The separation distance is dependent on the height of the minor source's emission point (such as a flue), the type of fuel or waste burned, and the quality of the fuel (sulfur, ash, or lead content). This criterion is designed to avoid undue influences from minor sources.

<sup>7</sup> For microscale CO monitoring sites, the probe must be >10 meters from a street intersection and preferably at a midblock location.

<sup>8</sup> Collocated monitors must be within 4 meters of each other and at least 2 meters apart for flow rates

<sup>2</sup> <http://www.access.gpo.gov/nara/cfr/cfr-table-search.html>

**Table 7-3 Minimum Separation Distance Between Roadways and Sampling Probes or Monitoring Paths at Neighborhood and Urban Scales for O<sub>3</sub>, Oxides of Nitrogen (NO, NO<sub>2</sub>, NO<sub>x</sub>, NO<sub>y</sub>) and CO**

Roadway ave. daily traffic vehicles per day	O <sub>3</sub> and Oxides of N Neighborhood & Urban <sup>1</sup>	O <sub>3</sub> and Oxides of N Neighborhood & Urban <sup>1&amp; 2</sup>	CO Neighborhood
≤ 1,000	10	10	
10,000	10	20	
≤ 10,000			10
15,000	20	30	25
20,000	30	40	45
30,000			80
40,000	50	60	115
50,000			135
≥ 60,000			150
70,000	100	100	
≥110,000	250	250	

<sup>1</sup> Distance from the edge of the nearest traffic lane. The distance for intermediate traffic counts should be interpolated from the table values based on the actual traffic count.

<sup>2</sup> Applicable for ozone monitors whose placement has not already been approved as of December 18, 2006.

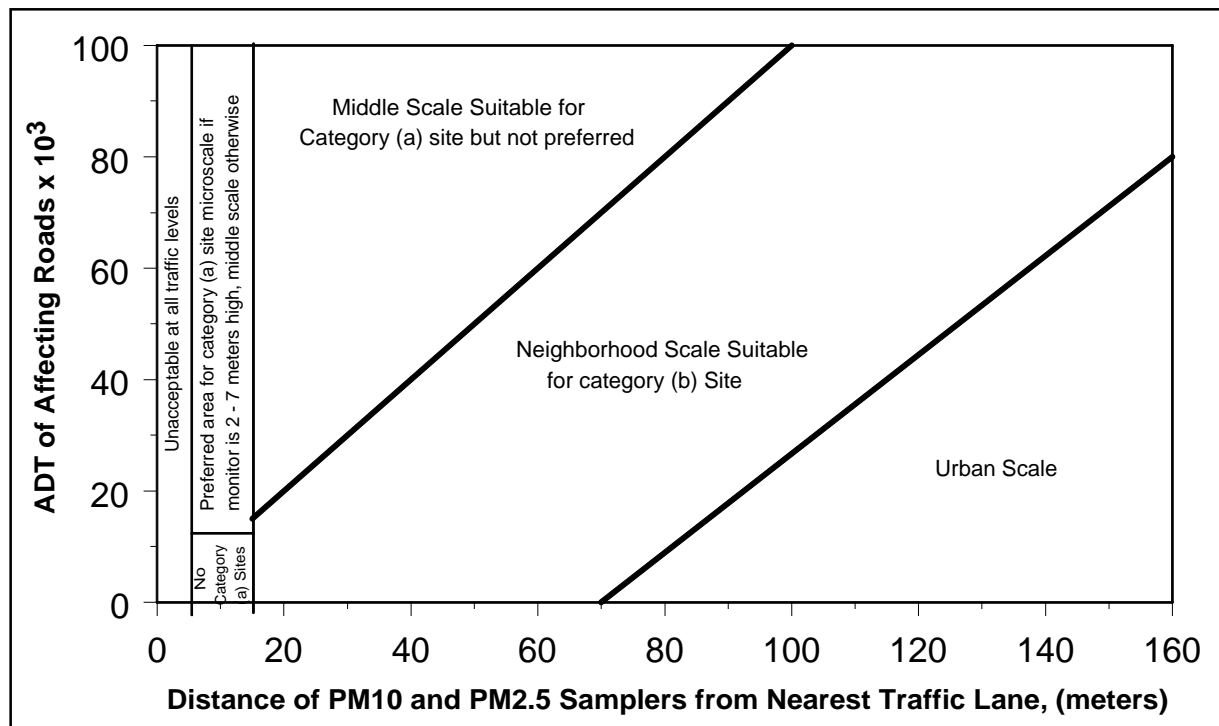

**Figure 7.3 Acceptable areas for PM<sub>10</sub> and PM<sub>2.5</sub> micro, middle, neighborhood, and urban samplers except for microscale street canyon sites**

## Open Path Monitoring

To ensure that open path monitoring data are representative of the intended monitoring objective(s), specific path siting criteria are needed. 40 CFR Part 58, Appendix E, contains specific location criteria applicable to monitoring paths after the general station siting has been selected based on the monitoring objectives, spatial scales of representativeness, and other considerations presented in Appendix D. The new open path siting requirements largely parallel the existing requirements for point analyzers, with the revised provisions applicable to either a "probe" (for point analyzers), a "monitoring path" (for open path analyzers), or both, as appropriate. Criteria for the monitoring path of an open path analyzer are given for horizontal and vertical placement, spacing from minor sources, spacing from obstructions, spacing from trees, and spacing from roadways. These criteria are summarized in Table 7-2.

**Cumulative Interferences on a Monitoring Path:** To control the sum effect on a path measurement from all the possible interferences which exist around the path, the cumulative length or portion of a monitoring path that is affected by obstructions, trees, or roadways must not exceed 10 percent of the total monitoring path length. This limit for cumulative interferences on the monitoring path controls the total amount of interference from minor sources, obstructions, roadways, and other factors that might unduly influence the open path monitoring data.

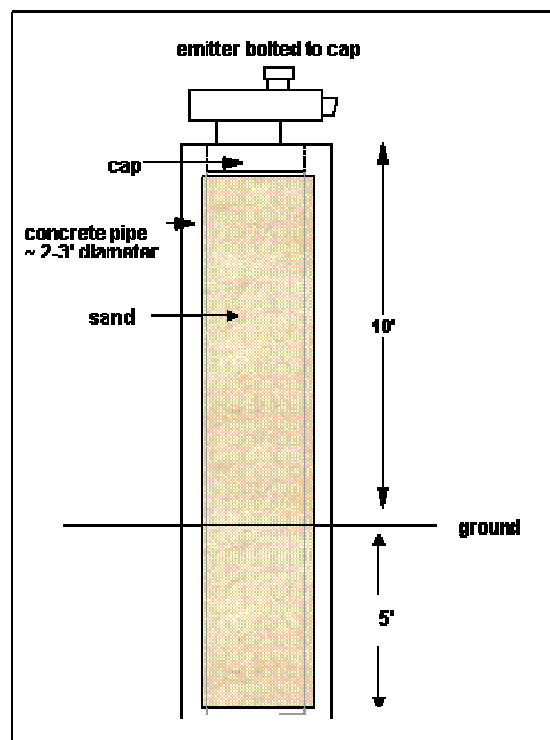

Figure 7.4 Optical mounting platform

**Monitoring Path Length:** For  $\text{NO}_2$ ,  $\text{O}_3$  and  $\text{SO}_2$ , the monitoring path length must not exceed 1 kilometer for analyzers in neighborhood, urban, or regional scales, or 300 meters for middle scale monitoring sites. These path limitations are necessary in order to produce a path concentration representative of the measurement scale and to limit the averaging of peak concentration values. In addition, the selected path length should be long enough to encompass plume meander and expected plume width during periods when high concentrations are expected. In areas subject to frequent periods of rain, snow, fog, or dust, a shortened monitoring path length should be considered to minimize the loss of monitoring data due to these temporary optical obstructions.

### Mounting of Components and Optical Path

**Alignment:** Since movements or instability can misalign the optical path, causing a loss of light and less accurate measurements or poor readings, highly stable optical platforms are critical. Steel buildings and wooden platforms should be avoided as they tend to move more than brick buildings when wind and temperature conditions vary. Metal roofing will, for example, expand when heated by the sun in the summer. A concrete pillar with a wide base, placed upon a stable base material, has

been found to work well in field studies. A sketch of an optical platform is included in Figure 7.4.

### 7.2.3 Probe and Manifold Maintenance

After an adequately designed sampling probe and/or manifold has been selected and installed, the following steps will help in maintaining constant sampling conditions:

1. Conduct a leak test. For the conventional manifold, seal all ports and pump down to approximately 1.25 cm water gauge vacuum, as indicated by a vacuum gauge or manometer connected to one port. Isolate the system. The vacuum measurement should show no change at the end of a 15-min period.
2. Establish cleaning techniques and a schedule. A large diameter manifold may be cleaned by pulling a cloth on a string through it. Otherwise the manifold must be disassembled periodically and cleaned with distilled water. Soap, alcohol, or other products that may contain hydrocarbons should be avoided when cleaning the sampling train. These products may leave a residue that may affect volatile organic measurements. Visible dirt should not be allowed to accumulate.
3. Plug the ports on the manifold when sampling lines are detached.
4. Maintain a flow rate in the manifold that is either 3 to 5 times the total sampling requirements or at a rate equal the total sampling requirement plus 140 L/min. Either rate will help to reduce the sample residence time in the manifold and ensure adequate gas flow to the monitoring instruments.
5. Maintain the vacuum in the manifold <0.64 cm water gauge. Keeping the vacuum low will help to prevent the development of leaks.

### 7.2.4 Support Services

Most of the support services necessary for the successful operation of ambient air monitoring networks can be provided by the laboratory. The major support services are the generation of reagent water and the preparation of standard atmospheres for calibration of equipment. Table 7-4 summarizes guidelines for quality control of these two support services.

In addition to the information presented above, the following should be considered when designing a sampling manifold:

- suspending strips of paper in front of the blower's exhaust to permit a visual check of blower operation;
- positioning air conditioner vents away from the manifold to reduce condensation of water vapor in the manifold ;
- positioning sample ports of the manifold toward the ceiling to reduce the potential for accumulation of moisture in analyzer sampling lines, and using borosilicate glass, stainless steel, or their equivalent for VOC sampling manifolds at PAMS sites is to avoid adsorption and desorption reactions of VOC's on FEP Teflon;
- if moisture in the sample train poses a problem (moisture can absorb gases, namely NO<sub>x</sub> and SO<sub>2</sub>), wrap the manifold and instrument lines with "heat wrap", a product that has heating coils within a cloth covering that allows the manifold to be maintained at a constant temperature that does not increase the sampled air temperature by more than 3-5 degrees C above ambient temperature;
- ensuring the manifold has a moisture trap and that it is emptied often; and
- using water resistant particulate filters in-line with the instrument.

**Table 7-4 Techniques for Quality Control of Support Services**

Support	Parameters affecting quality	Control techniques
Laboratory and calibration gases	Purity specifications vary among manufacturers Variation among lots Atmospheric interferences Composition	Develop purchasing guides Overlap use of old and new cylinders Adopt filtering and drying procedures Ensure traceability to primary standard
Reagents and water	Commercial source variation Purity requirements Atmospheric interferences Generation and storage equipment	Develop purchasing guides. Batch test for conductivity Redistillation, heating, deionization with ion exchange columns Filtration of exchange air Maintenance schedules from manufacturers

### 7.3 Reference/Equivalent Methods and Approved Regional Methods

For monitoring in a SLAMS network, either reference or equivalent methods are usually required. This requirement, and any exceptions, are specified in 40 CFR Part 58, Appendix C<sup>3</sup>. In addition, reference or equivalent methods may be required for other monitoring applications, such as those associated with prevention of significant deterioration (PSD). Requiring the use of reference or equivalent methods helps to assure the reliability of air quality measurements including: ease of specification, guarantee of minimum performance, better instruction manuals, flexibility of application, comparability with other data and increased credibility of measurements. However, designation as a reference or equivalent method provides no guarantee that a particular analyzer will always operate properly. 40 CFR Part 58, Appendix A requires the monitoring organization to establish an internal QC program. Specific guidance for a minimum QC program is described in Section 10 of this Handbook.

The definitions and specifications of reference and equivalent methods are given in 40 CFR Part 53. For most monitoring applications, the distinction between reference and equivalent methods is unimportant and either may be used interchangeably.

Reference and equivalent methods may be either manual or automated (analyzers). For SO<sub>2</sub>, particulates, and Pb, the reference method for each is a unique manual method that is completely specified in 40 CFR Part 50 (Appendices A, and G respectively); all other approved methods for SO<sub>2</sub> and Pb qualify as equivalent methods. For CO, NO<sub>2</sub>, and O<sub>3</sub>, Part 50 provides only a measurement principle and calibration procedure applicable to reference methods for these pollutants. Automated methods (analyzers) for these pollutants may be designated as either reference methods or equivalent methods, depending on whether the methods utilize the same measurement principle and calibration procedure specified in Part 50. Because any analyzer that meets the requirements of the specified measurement principle and calibration procedure may be designated as a reference method, there are numerous reference methods for CO, NO<sub>2</sub>, and O<sub>3</sub>. Further information on this subject is in the preamble to 40 CFR Part 53.

<sup>3</sup> <http://www.access.gpo.gov/nara/cfr/cfr-table-search.html> All references to CFR in following section can be found at this site.

Except for the unique reference methods for SO<sub>2</sub>, particulates, and Pb specified in 40 CFR Part 50, all reference and equivalent methods must be officially designated as such by EPA under the provisions of 40 CFR Part 53. Notice of each designated method is published in the *Federal Register* at the time of designation. A current list of all designated reference and equivalent methods is maintained and updated by EPA whenever a new method is designated. This list can be found on AMTIC<sup>4</sup>. Moreover, any analyzer offered for sale as a reference or equivalent method after April 16, 1976 must bear a label or sticker indicating that the analyzer has been designated as a reference or equivalent method by EPA.

Sellers of designated automated methods must comply with the conditions summarized below:

1. A copy of the approved operation or instruction manual must accompany the analyzer when it is delivered to the purchaser.
2. The analyzer must not generate any unreasonable hazard to operators or to the environment.
3. The analyzer must function within the limits of the performance specifications in Table 7-5 for at least 1 year after delivery when maintained and operated in accordance with the operation manual.
4. Any analyzer offered or sale as a reference or equivalent method must bear a label or sticker indicating that it has been designated as a reference or equivalent method in accordance with 40 CFR Part 53.
5. If such an analyzer has one or more selectable ranges, the label or sticker must be placed in close proximity to the range selector and must indicate which range or ranges have been designated as reference or equivalent methods.
6. An applicant who offers analyzers for sale as reference or equivalent methods is required to maintain a list of purchasers of such analyzers and to notify them within 30 days if a reference or equivalent method designation applicable to the analyzers has been canceled or if adjustment of the analyzers is necessary under 40 CFR Part 53.11(b) to avoid a cancellation.

Accordingly, in selecting a designated method for a particular monitoring application, consideration should be given to such aspects as:

- the suitability of the measurement principle;
- the suitability for the weather and/or geographic conditions at the site;
- analyzer sensitivity and available operating ranges suitable for the site;
- susceptibility to interferences that may be present at the monitoring site;
- requirements for support gases or other equipment;
- reliability;
- maintenance requirements;
- initial as well as operating costs;
- features such as internal or fully automatic zero and span checking or adjustment capability, etc.;
- compatibility to your current and future network, i.e. software and connections (RS 232, Ethernet); and
- manual or automated methods.

---

<sup>4</sup> <http://www.epa.gov/ttn/amtic/criteria.html>



It is important that the purchase order for a new reference or equivalent analyzer specify the designation by the EPA.

The required performance specifications, terms of the warranty, time limits for delivery and acceptance testing, and what happens in the event that the analyzer falls short of performance requirements should be documented. Aside from occasional malfunctions, consistent or repeated noncompliance with any of these conditions should be reported to EPA. In selecting designated methods, remember that designation of a method indicates only that it meets certain minimum standards. Competitive differences still exist among designated analyzers. Some analyzers or methods may have performance, operational, economic or other advantages over others. A careful selection process based on the individual air monitoring application and circumstances is very important.

Some of the performance tests and other criteria used to qualify a method for designation as a reference or equivalent method are intended only as pass/fail tests to determine compliance with the minimum standards. Test data may not allow quantitative comparison of one method with another.

**Table 7-5 Performance Specifications for Automated Methods**

Performance Parameter	Units	SO <sub>2</sub>	O <sub>3</sub>	CO	NO <sub>2</sub>	Def and Test procedure-CFR Sec
1) Range	ppm	0-0.5	0-0.5	0-50	0-0.5	53.23(a)
2) Noise	ppm	0.005	0.005	0.50	0.005	53.23(b)
3) Lower detectable limit	ppm	0.01	0.01	1.0	0.01	53.23(c)
4) Interference equivalent Each Interferant Total Interferant	ppm	$\pm 0.02$ 0.06	$\pm 0.02$ 0.06	$\pm 1.0$ 1.5	$\pm 0.02$ 0.04	53.23(d)
5) Zero drift, 14 and 24 hour	ppm	$\pm 0.2$	$\pm 0.2$	$\pm 1.0$	$\pm 0.2$	53.23(e)
6) Span drift, 24 hour 20% of upper range limit 80% of upper range limit	percent	$\pm 20.0$ $\pm 5.0$	$\pm 20.0$ $\pm 5.0$	$\pm 10.0$ $\pm 2.5$	$\pm 20.0$ $\pm 5.0$	53.23(e)
7) Lag time	minutes	20	20	10	20	53.23(e)
8) Rise Time	minutes	15	15	5	15	53.23(e)
9) Fall Time	minutes	15	15	5	15	53.23(e)
10) Precision 20% of upper range limit 80% of upper range limit	ppm	0.01 0.015	0.01 0.01	0.5 0.5	0.02 0.03	53.23(e)

### FRM/FEM Designated Operating Ranges and the Affect of Span Checks

Although all FRM/FEMs are required to meet the range specified in Table 7-5, many instruments are designated for ranges narrower and or broader than the requirement. During the equipment purchase/selection phase, monitoring organizations should select an instrument with ranges most appropriate to the concentration at the site which the instrument will be established and then use the range that is most appropriate for the monitoring situation. Earlier versions of this Handbook suggested that the concentration of the span checks be 70 – 90% of the analyzers measurement range. Using this guidance and the designated ranges of some of the FRM/FEM method being used, a span check might be selected at a concentration that is never found in the ambient air at the site for which the monitoring is operating. The span check concentration should be selected that is more beneficial to the quality control of the routine data at the site and EPA suggests: 1) the selection of an appropriate measurement range and 2) selecting a span that at a minimum is above 120% of the highest NAAQS (for sites used for designation purposes) and above the 99% of the routine data over a 3 year period. The multi-point verification/calibrations that are performed at a minimum annually can be used to challenge the instrument and confirm linearity and calibration slope of the selected operating range.

## PM<sub>2.5</sub> Reference and Equivalent Methods

All formal sampler design and performance requirements and the operational requirements applicable to reference methods for PM<sub>2.5</sub> are specified in 40 CFR Part 50, Appendix L. These requirements are quite specific and include explicit design specifications for the type of sampler, the type of filter, the sample flow rate, and the construction of the sample collecting components. However, various designs for the flow-rate control system, the filter holder, the operator interface controls, and the exterior housing are possible. Hence, various reference method samplers from different manufacturers may vary considerably in appearance and operation. Also, a reference method may have a single filter capability (single) or a multiple filter capability (sequential), provided no deviations are necessary in the design and construction of the sample collection components specified in the reference method regulation. A PM<sub>2.5</sub> method is not a reference method until it has been demonstrated to meet all the reference method regulatory requirements and has been officially designated by EPA as a reference method for PM<sub>2.5</sub>.

Equivalent methods for PM<sub>2.5</sub> have a wider latitude in their design, configuration, and operating principle than reference methods. These methods are not required to be based on filter collection of PM<sub>2.5</sub>; therefore, continuous or semi-continuous analyzers and new types of PM<sub>2.5</sub> measurement technologies are not precluded as possible equivalent methods. Equivalent methods are not necessarily required to meet all the requirements specified for reference methods, but they must demonstrate both **comparability** to reference method measurements and similar PM<sub>2.5</sub> **measurement precision**.

The requirements that some (but not all) candidate methods must meet to be designated by EPA as equivalent methods are specified in 40 CFR Part 53. To minimize the difficulty of meeting equivalent method designation requirements, three classes of equivalent methods have been established in the 40 CFR Part 53 regulations, based on a candidate method's extent of deviation from the reference method requirements. All three classes of equivalent methods are acceptable for SLAMS or SLAMS-related PM<sub>2.5</sub> monitoring. But not all types of equivalent methods may be equally suited to various PM<sub>2.5</sub> monitoring requirements or applications.

**Class I** equivalent methods are very similar to reference methods, with only minor deviations, and must meet nearly all of the reference method specifications and requirements. The requirements for designation as Class I equivalent methods are only slightly more extensive than the designation requirements for reference methods. Also, because of their substantial similarity to reference methods, Class I equivalent methods operate very much the same as reference methods.

**Class II** equivalent methods are filter-collection-based methods that differ more substantially from the reference method requirements. The requirements for designation as Class II methods may be considerably more extensive than for reference or Class I equivalent methods, depending on the specific nature of the variance from the reference method requirements.

**Class III** equivalent methods cover any PM<sub>2.5</sub> methods that cannot qualify as reference or Class I or II equivalent methods because of more profound differences from the reference method requirements. This class encompasses PM<sub>2.5</sub> methods such as continuous or semi-continuous PM<sub>2.5</sub> analyzers and potential new PM<sub>2.5</sub> measurement technologies. The requirements for designation as Class III methods are the most extensive, and, because of the wide variety of PM<sub>2.5</sub> measurement principles that could be employed for candidate Class III equivalent methods, the designation requirements are not explicitly provided in 40 CFR Part 53.

## Approved Regional Methods (ARM)

There are some continuous PM<sub>2.5</sub> methods that currently may not be able to meet the national FRM and FEM designation criteria. However, these methods may operate at acceptable levels of data quality in certain regions of the country or under certain conditions. The EPA has expanded the use of alternative PM<sub>2.5</sub> measurement methods through ARMs. A method for PM<sub>2.5</sub> that has not been designated as an FRM or FEM as defined in 40 CFR Part 50.1 may be approved as an ARM. If a monitoring organization feels that a particular method may be suitable for use in its network, it can apply for the method to be designated as an ARM. The following provides a summary of the ARM requirements.

### PM<sub>2.5</sub> ARM Criteria Summary

1. Must meet Class III Equivalency Criteria
  - Precision
  - Correlation
  - Additive and multiplicative bias
2. Tested at site(s) where it will be used
  - 1 site in each MSA/CMSA up to the first 2 highest pop MSA/CMSA
  - 1 site in rural area or Micropolitan Statistical Area
  - Total of 3

If the ARM has been approved by another agency then:

- 1 site in MSA/CMSA and 1 site in rural area or Micropolitan Statistical Area
  - Total of 2
3. 1 year of testing all seasons covered
    - 90 valid sample pairs per site with at least 20 valid sample pairs per season.
    - Values < 3 ug/m<sup>3</sup> may be excluded in bias estimates but this does not affect completeness criteria.
  4. Collocation to establish precision not required
    - peer reviewed published literature or data in AQS that can be presented is enough
  5. ARM must be operated on an hourly sampling frequency providing for aggregation into 24-hour average measurements.
  6. Must use approved inlet and separation devices (Part 50 Appendix L or FEM Part 53)
    - Exception –methods that by their inherent measurement principle may not need an inlet or separation device.
  7. Must be capable of providing for flow audits
    - Exception –that by their inherent measurement principle measured flow is not required.
  8. Monitoring agency must develop and implement appropriate procedures for assessing and reporting precision and bias.

### Routine Monitoring Implementation

9. Collocation of ARM and FRM/FEM at 30% of SLAMS network or at least 1/network
  - At 1 in 6 day sampling frequency
  - Located at design value site among the largest MSA/CMSA
  - Collocated FRM/FEM can be substituted for ARM if ARM is invalidated
10. Collocation ARM with ARM
  - 7.5% of sites or at least 1 site
11. Bias assessment (PEP)
  - Same frequency as Appendix A

### ARM Approval

1. New ARM- EPA NERL, RTP, NC
2. ARM that has been approved by another agency- EPA Regional Administrator

## 8.0 Sample Handling and Custody

A critical activity within any data collection phase involving physical samples is the handling of sample media prior to sampling, handling/transporting sample media to the field, handling samples from the field at the time of collection, storage of samples (at field or other locations), transport of samples from the field site, and the analysis of the samples. Documentation ensuring that proper handling has occurred throughout these activities is part of the custody record, which provides a mechanism for tracking samples through sample collection, processing and analysis. Custody records document the “chain of custody”; the date and person responsible for the various sample handling steps associated with each sample. Custody records also provide a reviewable trail for quality assurance purposes and as evidence in legal proceedings.

Prior to the start of an EDO, the various types of samples should be identified and the following questions asked:

- Does the sample need to be analyzed within a specified time period?
- What modes of sample transport are necessary and how secure should they be?
- What happens if a sample is collected on Friday? Is the sample shipped or stored at the field office and what are the procedures?
- Can the sample’s integrity be affected by outside influences (e.g. temperature, pressure, humidity, jostling/dropping during shipment, other influences) and do these need to be monitored (e.g., max/min thermometers, pressure sensors)?
- How critical is it that sample integrity be known (e.g., is evidence tape necessary)?
- How can it be documented that sample integrity was maintained from the collection to reporting?
- What are the procedures when sample integrity is compromised (e.g., flag, don’t analyze)?

These are some of the questions that should be answered and documented in the monitoring organization’s QAPP and SOPs.

This section specifically addresses the handling and custody of physical environmental samples (e.g., exposed filters for particulate matter (PM) determinations and canisters containing whole air samples) that are collected at a field location and transported to a laboratory for analysis. For specific details of sample handling and custody (i.e., PAMS, NATTS, STN etc) monitoring organization should consult the appropriate technical assistance documents located in the National Programs summaries in Appendix A.

In addition to physical samples, some types of field data collected in hard copy (e.g., strip charts, sampler flow data, etc.) or electronic (e.g., data downloaded from a data logger with limited storage space) format are irreplaceable and represent primary information about physical samples or on-site measurements that are needed to report a final result. When such hard copy or electronic data are transported and/or change custody, it is advised that the same chain of custody practices described in this section for physical samples be employed to ensure that irreplaceable data can be tracked and are not altered or tampered with.

For additional information, an EPA on-line self-instructional course, “*Chain-of-Custody Procedures for Samples and Data*”<sup>1</sup> is available for review. The National Enforcement Investigation Center<sup>2</sup> (NEIC) also offers a course relevant to chain of custody issues.

---

<sup>1</sup> <http://www.epa.gov/apti/coc/>

<sup>2</sup> <http://www.epa.gov/compliance/about/offices/division/neic.html>

## Laboratory Information Management Systems

A laboratory information management system or LIMS, is a computer system used in the laboratory for the management and tracking of samples, instruments, standards and other laboratory functions such as data reductions, data transfer and reporting. The goal is to create an EDO where:

- Instruments used are integrated in the lab network; receive instructions and worklists from the LIMS and return finished results including raw data back to a central repository where the LIMS can update relevant information to external systems (i.e., AIRNow or AQS).
- Lab personnel will perform calculations, documentation and review results using online information from connected instruments, reference databases and other resources using electronic lab notebooks connected to the LIMS.
- Management can supervise the lab process, react to bottlenecks in workflow and ensure regulatory demands are met.
- External participants can review results and print out analysis certificates and other documentation (QA Reports, quality control charts, outlier reports etc.).

For monitoring programs that are fairly stable, such as criteria pollutant monitoring, development of a LIMS system may be very cost effective and should be considered. There is an upfront cost in the development of these systems but monitoring organizations that have devoted resources to their development have seen pay offs in improved data quality, sample tracking and data reporting.

### 8.1 Sample Handling

In the Ambient Air Quality Monitoring Program, discrete samples from manual methods associated with SLAMS, PAMS, NATTS, and other networks, are physically handled prior to analysis. One must pay particular attention to the handling of filters for particulate matter and lead since it has been suggested that the process of filter handling may be the largest source of measurement error (especially low-volume methods). Due to the manner in which concentrations are determined, it is critical that samples are handled as specified in SOPs. The various phases of sample handling that should be documented in a QAPP and SOP include:

- Sample preparation, labeling and identification;
- sample collection;
- transportation;
- sample analysis; and
- storage and archival

#### 8.1.1 Sample Preparation, Labeling and Identification

Sample containers or filters are cleaned and prepared (pre-weighing of filters) before being used to collect samples. SOPs should indicate the proper care and handling of the containers/filters to ensure their integrity. Proper lab documentation that tracks the disposition of containers/filters through preparation is just as important as the documentation after sampling. Care must be taken to properly mark all samples to ensure positive, unambiguous identification throughout the sample collection, handling, and analysis procedures. Figure 8.1 shows a standardized identification sticker that may be used to label physical samples. Additional information may be added as required, depending on the particular monitoring

program. The rules of evidence used in legal proceedings require that procedures for identification of samples used in analyses form the basis for future evidence. An admission by the laboratory analyst that he/she cannot be positive whether he/she analyzed sample No. 6 or sample No. 9, for example, could destroy the validity of the entire test report. Any information that can be used to assess sample integrity, such as the pressure of canisters or liquid level, should be recorded at the time of sample collection. Liquid levels for samples in non-graduated containers can be marked on the side of the container with a grease pencil or permanent marker.

Positive identification also must be provided for any filters used in the program. If ink is used for marking, it must be indelible and unaffected by the gases and temperatures to which it will be subjected. Other methods of identification can be used (e.g., bar coding), if they provide a positive means of identification and do not impair the capacity of the filter to function.

(Name of Sampling Organization)	
Sample ID No: _____	Storage Conditions: _____
Sample Type: _____	Site Name: _____
Date/Time Collected: _____	Site Address: _____
Sampler: _____	

**Figure 8.1 Example Sample Label.**

### 8.1.2 Sample Collection

To reduce the possibility of invalidating the results, all collected samples must be carefully removed from the monitoring device, placed in labeled, nonreactive containers, and sealed. Use of tamper-evident custody seals are suggested and may be required in certain cases. The sample label must adhere firmly to the container to ensure that it cannot be accidentally removed. Custody seals on sample containers serve two purposes: to prevent accidental opening of the sample container and to provide visual evidence should the container be opened or tampered with. The best type of custody seal depends on the sample container; often, a piece of tape placed across the seal and signed by the operating technician is sufficient; for other containers, wire locks or tie wraps may be the best choice. In some cases, the opening of sample containers by unauthorized personnel, such as Transportation Security Administration officers, cannot be avoided. The proper use of custody seals minimizes the loss of samples and provides direct evidence whether sample containers have been opened and possibly compromised. Samples whose integrity is questioned should be qualified (flagged).

### 8.1.3 Sample Transportation

Samples should be delivered to the laboratory for analysis as soon as possible following sample collection. It is recommended that this be done on the same day that the sample is taken from the monitor. If this is impractical, all the samples should be placed in transport containers (e.g., carrying case, cooler, shipping box, etc.) for protection from breakage, contamination, and loss and in an appropriate controlled-temperature device (i.e., refrigerator or freezer) if the samples have specific temperature requirements. Each transport container should have a unique identification, such as sampling location, date, and transport container number (e.g., number 2 of 5) to avoid interchange and aid in tracking the complete shipment. The number of the transport containers should be subsequently recorded

on the chain of custody (COC) form (described in Section 8.2) along with the sample identification numbers of the samples included within each transport container. It is advised that the container be sealed using an appropriate tamper-evident method, such as with custody tape or a wire lock.

In transporting samples, it is important that precautions be taken to eliminate the possibility of tampering, accidental destruction, and/or physical and chemical action on the sample. The integrity of samples can be affected by temperature extremes, air pressure (air transportation), and the physical handling of samples (packing, jostling, etc.). These practical considerations must be dealt with on a site-by-site basis and should be documented in the organization's QAPP and site specific SOPs.

The person who has custody of the samples must be able to testify that no tampering occurred. Security must be continuous. If the samples are put in a vehicle, lock the vehicle. After delivery to the laboratory, the samples must be kept in a secured place with restricted access.

#### **8.1.4 Sample Analysis**

SOPs, if properly developed, have detailed information on the handling of samples at the analysis phase. Similar to the preparation step, if the sample undergoes a number of steps (preparation, equilibration, extraction, dilution, analysis, etc.), and these steps are performed by different individuals, there should be a mechanism in place to track the sample through the steps to ensure SOPs are followed and the integrity of the sample was maintained. Laboratories make extensive use of laboratory notebooks at the various steps (stations) of the analytical process to record the sample handling process and maintain sample integrity.

#### **8.1.5 Storage and Archival**

Samples must be properly handled to ensure that there is no contamination and that the sample analyzed is actually the sample taken under the conditions reported. For this reason, whenever samples are not under the direct control of the sample custodian, they should be kept in a secured location. This may be a locked vehicle, locked refrigerator, or locked laboratory with limited access. It is highly recommended that all samples be secured until discarded. These security measures should be documented by a written record signed by the handlers of the sample on the COC form or in a laboratory notebook, indicating the storage location and conditions. Any samples not destroyed during the analysis process (e.g., exposed filters for PM) should be archived as directed by the method requirements or applicable QAPP. 40 CFR Part 58.16 requires PM<sub>10</sub>, PM<sub>10-2.5</sub> and PM<sub>2.5</sub> filters from SLAMS manual low-volume samplers be archived for 1 year from collection. However, it is suggested that they be archived the first year in cold conditions (e.g., at 4° C) and at room temperature for 2 additional years. It is also suggested that non-destructive lead analysis and STN samples follow this guidance.

### **8.2 Chain of Custody (COC)**

In order to use the results of a sampling program as evidence, a written record must be available listing the location of the samples at all times. This is also an important component of good laboratory practices<sup>3</sup>. The COC record is necessary to make a prima facie showing of the integrity of the samples. Without it, one cannot be sure that the samples and sampling data analyzed were the same as the samples and data reported to have been taken at a particular time. Procedures may vary, but an actual COC record sheet with the names and signatures of the relinquishers/receivers works well for tracking physical

---

<sup>3</sup> [http://www.fda.gov/ora/compliance\\_ref/bimo/glp/default.htm](http://www.fda.gov/ora/compliance_ref/bimo/glp/default.htm)

samples. The samples should be handled only by persons associated in some way with the monitoring program. A good general rule to follow is “the fewer hands the better,” even though a properly sealed sample may pass through a number of hands without affecting its integrity.

Each person handling the samples must be able to state from whom and when the item was received and to whom and when it was delivered. A COC form should be used to track the handling of the samples through various stages of storage, processing, and analysis at the laboratory. It is recommended practice to have each person who relinquishes or receives samples sign the COC form for the samples. An example of a form that may be used to establish the COC for samples generated in the field is shown in Figure 8.2. This form should accompany the samples at all times from the field to the laboratory. All persons who handle the samples should sign the form. Figure 8.3 is an example of a laboratory COC form. COC forms should be retained and archived as described in Section 5 (Documents and Records).

When using professional services to transport physical samples, only reliable services that provide a tracking number should be used. Information describing the enclosed samples should be placed on the bill of lading. A copy of the shipping receipt and tracking number should be kept as a record. The package should be addressed to the specific person authorized to receive the package, although it is recognized that staff not typically part of the COC may receive the samples and deliver them to the authorized addressee. A procedure must be in place to ensure that samples are delivered to the appropriate person without being opened or damaged. In this circumstance, the sample is considered still in transport until received by the authorized addressee. It may be necessary to ship and/or receive samples outside of normal business hours. A procedure should be developed in advance that considers staff availability, secure storage locations, and appropriate storage conditions (e.g., temperature-controlled).

### **8.2.1 Sample Inspection and Acceptance**

Once the samples arrive at their destination and at every custody change, the samples should first be checked to ensure that their integrity is intact. The contents of the shipment should be checked against the COC form to ensure that all samples listed were included in the shipment. The levels of liquid samples should be compared to original levels (if marked on the container or recorded), to identify whether major leaks have occurred. When using passivated stainless steel canisters, the canister pressure, upon receipt, should be recorded and compared to the final sample collection pressure to indicate canister leakage and sample loss. It is recommended that this comparison be made using a certified gauge that is calibrated annually. Any samples whose integrity or identity are questionable should be brought to the attention of the relinquisher and flagged. All flags should be “carried” along with the samples until the validity of the samples can be proven. This information can be included in the remark section of the COC form.



Chain of Custody Record					
Project No.		Project Title			Organization
Shipping Container No.					
Field Samplers: <i>print</i>		<i>signature</i>			
					Address
Date	Time	Site/Location	Sample Type	Sample ID	Remarks
Relinquished by ( <i>print and signature</i> ):			Received by ( <i>print and signature</i> ):		Comments

Figure 8.2 Example Field COC Form.

Chain of Custody Record					
Project No.		Project Title			Organization
Laboratory/Plant: _____					
Sample Number	Number of Container	Sample Description			
Person responsible for samples			Time:		Date:
Sample Number	Relinquished By:	Received By:	Time:	Date:	Reason for change in custody

Figure 8.3 Example Laboratory COC Form.

## 9.0 Analytical Methods

The choice of methods used for any EDO should be influenced by the DQO. From the DQO and an understanding of the potential population uncertainty, one can then determine what measurement uncertainty is tolerable and select the method most appropriate in meeting that tolerance. Methods are usually selected based upon their performance characteristics (precision, bias, limits of detection), ease of use, and their reliability in field and laboratory conditions.

Since both field and analytical procedures have been developed for the criteria pollutants in the Ambient Air Quality Monitoring Program, and in the various technical assistance documents for the other national ambient air programs, this section will discuss the general concepts of standard operating procedures and good laboratory practices as they relate to the reference and equivalent methods. A more detailed discussion on the attributes of SOPs can be found in Section 5. Information on reference and equivalent methods can be found on the AMTIC website<sup>1</sup> as well as the current list of designated Federal Reference and Equivalent Methods<sup>2</sup>.

Many ambient air methods utilize continuous instruments and therefore do not involve laboratory analysis. However particulate matter methods involve both continuous and manual methods and some of the other major monitoring programs involve sampling which requires the use of laboratory analysis. Table 9-1 provides a summary of the pollutants measured and the analytical methods for these programs.

**Table 9-1 Acceptable Analytical Methods**

Network	Pollutant	Acceptable Method	Reference
SLAMS	PM <sub>10</sub> – Hi-Vol	Gravimetric	40 CFR Part 50 App B
SLAMS	PM <sub>10</sub> - dichot	Gravimetric	40 CFR Part 50 App J
SLAMS	PM <sub>2.5</sub>	Gravimetric	40 CFR Part 50 App L
SLAMS	PM <sub>10-2.5</sub>	Gravimetric- difference	
SLAMS	Pb	Atomic Absorption Spectrometry	40 CFR Part 50 App G
PAMS	VOCs	Gas Chromatography/Mass Spectrometry (GC/MS)	TO-15
PAMS	Carbonyl compounds	High Performance Liquid Chromatography (HPLC)	TO11-A
PAMS	Non-Methane Organic Compounds (NMOC)	Cryogenic Preconcentration and Direct Flame Ionization Detection (PDFID)	TO-12
NATTS	Metals	Inductively coupled plasma (ICP)	IO 3.5
NATTS	Aldehydes	High Pressure Liquid Chromatography	TO11-A
NATTS	VOCs	Gas Chromatography	TO-15
STN	PM <sub>2.5</sub>	Gravimetric	40 CFR Part 50 App L
STN	Elements	Energy Dispersive X-Ray Fluorescence (EDXRF)	STN QAPP and SOPs
STN	Anions		STN QAPP and SOPs
STN	Cations		STN QAPP and SOPs
STN	Organic, Elemental, Carbonate, Total Carbon	Thermal Optical Carbon Analyzer	STN QAPP and SOPs
STN	Semi-volatile Organic Compounds	Gas Chromatography/Mass Spectrometry (GC/MS)	STN QAPP and SOPs

The SLAMS network provides more rigorous quality control requirements for the analytical methods. These methods are found in 40 CFR Part 50, as described in the references. In addition, the method identified for Pb is the reference method. There are a number of equivalent analytical methods that are

<sup>1</sup> <http://www.epa.gov/ttnamti1/pmfrm.html>

<sup>2</sup> <http://www.epa.gov/ttn/amtic/criteria.html>

available for the Pb. Some of the NATTS methods are derived from the Toxics Organic Method Compendium<sup>3</sup>. Others, like the STN Network<sup>4</sup> may be developed specifically for the program, based on the national laboratory currently performing the analysis. The PAMS, NATTS and STN networks follow the performance based measurement process paradigm. These Networks' QA project plans or technical assistance documents suggest a method, but also allow some flexibility to use other methods that meet the network's measurement quality objectives. Various, independent proficiency test samples and technical systems audits are performed to ensure that the data quality within these networks remains acceptable.

## 9.1 Good Laboratory Practices

Good laboratory practices (GLPs)<sup>5</sup> refer to general practices that relate to many, if not all, of the measurements made in a laboratory. They are usually independent of the SOP and cover subjects such as maintenance of facilities, records, sample management and handling, reagent control, and cleaning of laboratory glassware. In many cases, the activities mentioned above may not be formally documented because they are considered common knowledge. However, for consistency in laboratory technique, these activities should have some form of documentation.

## 9.2 Laboratory Activities

For ambient air samples to provide useful information or evidence, laboratory analyses must meet the following four basic requirements:

1. Equipment must be frequently and properly calibrated and maintained (Section 12).
2. Personnel must be qualified to make the analysis (Section 4).
3. Analytical procedures must be in accordance with accepted practice (Section 9.1 above).
4. Complete and accurate records must be kept (Section 5).

As indicated, these subjects are discussed in other sections of this document. For the Ambient Air Quality Monitoring Program, laboratory activities are mainly focused on the pollutants associated with manual measurements for lead, particulate matter (PM and STN), NATTS<sup>6</sup> and PAMS<sup>7</sup> (VOCs). However, many laboratories also prepare reference material, test or certify instruments, and perform other activities necessary to collect and report measurement data. Each laboratory should define these critical activities and ensure there are consistent methods for their implementation.

---

<sup>3</sup> <http://www.epa.gov/ttn/amtic/airtox.html>

<sup>4</sup> <http://www.epa.gov/ttn/amtic/specsop.html>

<sup>5</sup> <http://www.epa.gov/Compliance/monitoring/programs/fifra/glep.html>

<sup>6</sup> [http://www.epa.gov/ttn/amtic/files/ambient/airtox/NATTS\\_TAD\\_SECT\\_4.pdf](http://www.epa.gov/ttn/amtic/files/ambient/airtox/NATTS_TAD_SECT_4.pdf)

<sup>7</sup> <http://www.epa.gov/ttn/amtic/files/ambient/pams/newtad.pdf>

## 10.0 Quality Control

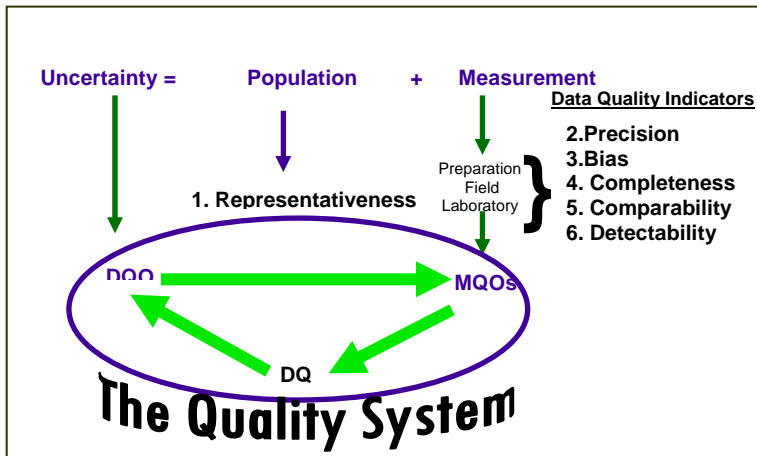

As described in Section 3, any data collection process that provides an estimate of a concentration contains uncertainties related to spatial/temporal variability (population) and the measurement process. DQOs define the data quality needed to make a correct decision an acceptable percentage of the time. Data quality is defined through quantification of the following **data quality indicators**.

**Representativeness** - the degree in which data accurately and precisely represent a characteristic of a population, parameter variation at a sampling point, a process condition, or an environmental condition.

**Precision** - a measure of mutual agreement among individual measurements of the same property usually under prescribed similar conditions. This is the random component of error. Precision is estimated by various statistical techniques using some derivation of the standard deviation.

**Bias** - the systematic or persistent distortion of a measurement process which causes error in one direction. Bias will be determined by estimating the positive and negative deviation from the true value as a percentage of the true value.

**Detectability** - The determination of the low range critical value of a characteristic that a method specific procedure can reliably discern.

**Completeness** - a measure of the amount of valid data obtained from a measurement system compared to the amount that was expected to be obtained under correct, normal conditions. Data completeness requirements are included in the reference methods (40 CFR Pt. 50).

**Comparability** - a measure of confidence with which one data set can be compared to another.

**Measurement quality objectives (MQOs)** identify the **quality control samples** and the acceptance criteria for those samples that will allow one to quantify the data quality indicators.

**Data quality assessments (DQAs)** are the statistical assessments that determine if the DQOs are met and to provide descriptions of data uncertainty. If the DQOs are not met, the DQAs are used to determine whether modifications to the DQOs are necessary or "tighter" **quality control** is required.

Within any phase or step of the data collection process, errors can occur. For example:

- samples and filters can be mislabeled;
- data can be transcribed or reported incorrectly or information management systems can be programmed incorrectly;
- calibration or check standards can be contaminated or certified incorrectly resulting in faulty calibrations;

- instruments can be set up improperly or over time fail to operate within specifications; and
- procedures may not be followed.

Quality Control (QC) is the overall system of technical activities that measures the attributes and performance of a process, item, or service against defined standards to verify that they meet the stated requirements established by the customer<sup>1</sup>. Quality control includes establishing specifications or acceptance criteria for each quality characteristic of the monitoring/analytical process, assessing procedures used in the monitoring/analytical process to determine conformance to these specifications, and taking any necessary corrective actions to bring them into conformance. The EPA’s QAPP guidance document QA/G5<sup>2</sup> suggests that “QC activities are those technical activities routinely performed, not to eliminate or minimize errors, but to measure their effect”. Although there is agreement that the measurement or assessment of a QC check or procedure does not itself eliminate errors, the QC data can and should be used to take appropriate corrective actions which can minimize error or control data to an acceptable level of quality in the future. So, QC is both proactive and corrective. It establishes techniques to determine if field and lab procedures are producing acceptable data and identifies actions to correct unacceptable performance.

The goal of quality control is to provide a reasonable level of checking at various stages of the data collection process to ensure that data quality is maintained and if it is found that the quality has not been maintained, that it is discovered with a minimal loss of data (invalidation). Figure 10.1 provides an example of some of the QC samples used in the PM<sub>2.5</sub> data collection process. The figure also identifies what sources of error are associated with the QC sample. So, in developing a quality control strategy, one must weigh the costs associated with quality control against the risks of data loss.

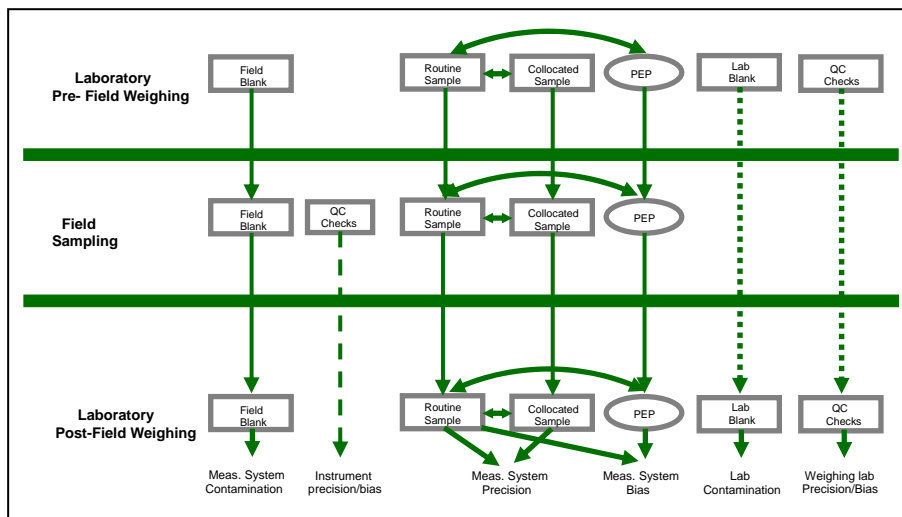

Figure 10.1 QC samples for PM<sub>2.5</sub> placed at various stages of measurement process

With the objective to minimize data loss, quality control data is most beneficial when it is assessed as soon as it is collected. Therefore, information management systems can play a very important role in reviewing QC data and flagging or identifying spurious data for further review. These information management procedures can help the technical staff review these QC checks coming from a number of

monitoring sites in a consistent and time efficient manner. There are many graphical techniques (e.g., control charts and outlier checks) that can be employed to quickly identify suspect data. More details of information management systems are discussed later in this section.

<sup>1</sup> American National Standard ANSI/ASQ E4-2000 <http://www.asq.org/>

<sup>2</sup> [http://www.epa.gov/quality/qa\\_docs.html](http://www.epa.gov/quality/qa_docs.html)

It is the responsibility of the monitoring organization, through the development of its QAPP, policies and procedures, to develop and document the:

- QC techniques;
- frequency of the QC checks and the point in the measurement process that the check is introduced;
- traceability of QC standards;
- matrix of the check sample;
- appropriate test concentrations;
- actions to be taken in the event that a QC check identifies a failed or changed measurement system;
- formulae for estimating data quality indicators;
- QC results, including control charts; and
- the means by which the QC data will be used to determine that the measurement performance is acceptable.

## 10.1 QC Activity Areas

For air monitoring projects the following three areas must have established QC activities, procedures and criteria:

1. Data Collection.
2. Data management and the verification and validation process.
3. Reference materials.

**Data collection** includes any process involved in acquiring a concentration or value, including but not limited to: sample preparation, field sampling, sample transportation, field analytical (continuous) methods, and laboratory preparation/analytical processes. Depending on the importance of the data and resources available, monitoring programs can implement QC samples, as illustrated in Figure 10.1, to identify the errors occurring at various phases of monitoring process. Many of the QC samples can identify errors from more than one phase. Table 10-1 provides a list of the majority of the QC samples utilized in the ambient air program and include both their primary and secondary uses in error identification. Many of these checks are required in CFR; others are strongly suggested in the method guidance. The MQO/validation templates provided in Appendix D provide the minimum requirements for the frequency that these checks be implemented but many monitoring organization choose more frequent checking in order to reduce the risk of data invalidation. A good example of this is the zero/span and one-point precision checks for the gaseous criteria pollutants. Although CFR requires the check to be performed once every two weeks, due to the advent of more sophisticated automated monitoring systems, many monitoring organization perform these checks every 24-hours (11:45 PM – 12:15 AM). In addition, once the QC checks are developed for a particular monitoring method, it is important to identify the acceptance criteria and what corrective action will be taken once a QC check fails. The MQO/Validation template in Appendix D can be used to list the QC samples with a column added to include corrective action. Table 10-2 provides an example of a QC Sample Table for PM<sub>2.5</sub>. Although the validation templates provide guidance for when data should be invalidated, it is up to the monitoring organization to provide the specific corrective actions for the failure of a specific QC check and therefore, Table 10-2 does not identify specific corrective actions.

**Data management** quality control is discussed in more detail in Section 14 and the verification/validation process in Section 17. However, both processes require some frequency of checks to ensure that they are performed consistently and without error. This is especially true for data management since errors in programming can cause consistent errors for long periods of time if not checked.

**Reference materials** are the standards by which many of the QC checks are performed. Reference material can be gaseous standards as well as devices (e.g., flow rate standards). If these standards are not checked and verified as to their certified values, then the quality of data becomes suspect. Reference materials need to be certified and recertified at acceptable frequencies in order to maintain the integrity of the reference material. It is suggested that standards be certified annually. More discussion on standards is included in Section 12.

## 10.2 Internal vs. External Quality Control

Quality control can be separated into 2 major categories: internal QC and external QC. Most of the quality control activities take place internally, meaning the monitoring organization responsible for collecting the data also develops and implements the quality control activities, evaluates the data, and takes corrective action when necessary. The internal activities can be used to take immediate action if data appear to be out of acceptance. External quality control samples are usually of two types: “double-blind” meaning the QC sample is not known (looks like a routine sample) and therefore its concentration is unknown, or “single-blind” meaning they are known to be a QC sample but its concentration is unknown. These samples are also called performance evaluation or proficiency test samples and are explained in Section 15. Because these checks are performed by external organizations, the results are not always immediately available and therefore have a diminished capacity to control data quality in “real-time.” However they are useful as an objective test of the internal QC procedures and may identify errors (i.e., biased or contaminated standards) that might go unnoticed in an internal QC system. Both types of quality control are important in a well implemented quality system. Other elements of an organization’s QAPP that may contain related sampling and analytical QC requirements include:

- **Sampling Design** which identifies the planned field QC samples as well as procedures for QC sample preparation and handling;
- **Sampling Methods Requirements** which includes requirements for determining if the collected samples accurately represent the population of interest;
- **Sample Handling and Custody Requirements** which discusses any QC devices employed to ensure samples are not tampered with (e.g., custody seals) or subjected to other unacceptable conditions during transport;
- **Analytical Methods Requirements** which includes information on the subsampling methods and information on the preparation of QC samples (e.g., blanks and replicates); and
- **Instrument Calibration and Frequency** which defines prescribed criteria for triggering recalibration (e.g., failed calibration checks).

**Table 10-1 QC Samples Used in Various Ambient Air Monitoring Programs**

Data Quality Indicator	QC Check and QC Sample	Sources of Measurement Error										Purpose To evaluate or determine the source of measurement error arising from:
		Sample Collection				Sample Transport	Field (continuous)/ Laboratory Analytical Method					
		Sampling Equipment	Conditions During Sampling	Preservation Technique	Sampling Matrix	Shipment Process	Sample Storage	Sample Preparation Reagents	Sample Preparation	Analytical Methods Reagents/Standards	Analytical Equipment	
Accuracy/Bias Positive or negative bias primarily due to contamination. (could also be due to operator error)	Lot Blank								✓✓			Filters that have not equilibrated
	Exposure Lot Blanks								✓✓	✓	✓	A batch of filters that have not equilibrated
	Laboratory Blanks						✓✓	✓✓	✓✓	✓✓	✓✓	Ambient contamination arising within laboratory or balance not operating
	Trip Blanks					✓✓	✓	✓	✓	✓	✓	Contamination from shipping and/or lab
	Field Blanks	✓✓	✓✓	✓✓		✓	✓	✓	✓	✓	✓	Ambient contamination from field activities sampling equipment, shipping and/or lab
	Reagent Blank			✓✓				✓	✓	✓	✓	Contamination introduced by reagents used in sample preparation/preservation.
Accuracy/Bias Due to sample matrix or sample preparation/ Analytical methodology	Equipment Blank (Rinsate Blank)	✓✓		✓		✓	✓	✓✓	✓✓	✓✓	✓✓	Carryover contamination resulting from successive use of sampling equipment.
	Matrix Spike				✓✓			✓	✓	✓	✓	Preparation/analytical bias for specific compounds in sample matrices
	Surrogate Spike				✓✓			✓	✓	✓	✓	Preparation/analytical bias for specific sample matrices
Accuracy/Bias due to inadequate temp. control	Lab Control Samples							✓✓	✓✓	✓✓	✓✓	Labs ability to accurately identify and quantitate target compounds
	Cooler Temp Check			✓✓		✓✓	✓✓					High temperatures causing volatilization affecting mass concentration
Accuracy/Bias Primarily due to equipment malfunction or not properly calibrated and/or operator error	Temp Verifications	✓✓					✓✓				✓✓	Sampler, sample storage, or laboratory prep facility problems
	Balance Check										✓✓	Analytical balance precision and stability
	Flow Rate Verifications/ Audits	✓✓									✓✓	Equipment not operating within specified parameters
	Humidity Verifications	✓✓							✓✓		✓✓	Laboratories inability to have an adequate measurement environment
	Pressure Verifications	✓✓										Sampler malfunction
	Leak Checks	✓✓										Sampler malfunction
	Timer Verifications	✓✓										Sampler malfunction
Precision/ Bias	Zero/Span								✓	✓	✓✓	Analyzer out of calibration or bad standards
	One-Point QC Check								✓	✓	✓✓	Analyzer out of calibration or bad standards
Precision	Collocated Samples	✓✓	✓	✓	✓✓	✓	✓	✓	✓	✓	✓	Cumulative effects of both field & lab precision to measure overall precision
	Field Duplicates	✓	✓	✓	✓✓	✓	✓	✓	✓	✓	✓	Cumulative effects of both field & lab precision to measure overall precision
	Sample /Analytical Replicate										✓✓	Filters not equilibrating, incorrect weighing procedure or balance problems
Accuracy/Bias	Standard Certifications	✓✓								✓✓	✓✓	Contaminated Reagents/Standards
	Calibrations	✓✓								✓✓	✓✓	Sampling analytical equipment bias or drift
	Round Robins								✓✓	✓✓	✓✓	Overall sampling/analysis process
Bias	Proficiency Tests								✓✓	✓✓	✓✓	Overall sampling/analysis process
	PEP	✓✓		✓		✓	✓		✓✓	✓✓	✓✓	Overall sampling/analysis process
Sensitivity	NPAP									✓✓	✓✓	Overall sampling/analysis process
	MDL Studies							✓✓	✓✓	✓✓	✓✓	



**Table 10-2 PM<sub>2.5</sub> Field and Lab QC Checks**

Requirement	Frequency	Acceptance Criteria	Corrective Action
<b>Field QC Checks</b>			
<b>Calibration Standards</b> Flow Rate Transfer Std. Field Thermometer Field Barometer	1/yr 1/yr 1/yr	±2% of NIST-traceable Std. ± 0.1° C resolution ± 0.5° C accuracy ± 1 mm Hg resolution ± 5 mm Hg accuracy	
<b>Calibration/Verification</b> Flow Rate (FR) Calibration FR multi-point verification One point FR verification External Leak Check Internal Leak Check Temperature Calibration Temp multi-point verification One- point temp Verification Pressure Calibration Pressure Verification Clock/timer Verification	If multi-point failure 1/yr 1/4 weeks every 5 sampling events every 5 sampling events If multi-point failure on installation, then 1/yr 1/4 weeks on installation, then 1/yr 1/4 weeks 1/4 weeks	± 2% of transfer standard ± 2% of transfer standard ± 4% of transfer standard 80 mL/min 80 mL/min ± 2% of standard ± 2° C of standard ± 4° C of standard ± 10 mm Hg ± 10 mm Hg 1 min/mo	
<b>Blanks</b> Field Blanks	See 2.12 reference	±30 µg	
<b>Precision Checks</b> Collocated samples	every 6 days	CV ≤ 10%	
<b>Audits (external assessments)</b> FRM PEP Flow rate audit External Leak Check Internal Leak Check Temperature Audit Pressure Audit	5 or 8 sites/year 1/6mo 1/6mo 1/6mo 1/6mo 1/6mo	± 10% ± 4% of audit standard < 80 mL/min < 80 mL/min ± 2° C ± 10 mm Hg	
<b>Laboratory QC Checks</b>			
<b>Blanks</b> Lot Blanks Lab Blanks	3-lot 3 per batch	±15 µg difference ±15 µg difference	
<b>Calibration/Verification</b> Balance Calibration Lab Temp. Calibration Lab Humidity Calibration	1/yr 3 mo 3 mo	Manufacturers spec. ± 2° C ±2%	
<b>Bias</b> Balance Audit Balance Check	1/year beginning, every 10th samples, end	±15 µg for unexposed filters ≤ ±3 µg	
<b>Calibration standards</b> Working Mass Stds. Primary Mass Stds.	3-6 mo. 1/yr	25 µg 25 µg	
<b>Precision</b> Duplicate filter weighings	1 per weighing session	±15 µg difference	

### 10.3 CFR Related Quality Control Samples

40 CFR Part 58, Appendix A identifies a number of quality control samples that must be implemented for the SLAMS (and NCore) SPM and PSD networks. By 2009, any special purpose monitors that use FRMs or FEMs will be required to follow these requirements unless granted a waiver by the Regional Administrator. Table 10-3 provides a summary of the QC checks for the criteria pollutants and the CFR reference where an explanation of each check is described. The reader should distinguish the requirements that are related to automated and manual methods since there are some differences.

**Table 10-3 Ambient Air Monitoring Measurement Quality Samples**

Method	CFR Reference	Coverage (annual)	Minimum frequency	MQOs*
<b>Automated Methods</b>				
<b>One-Point QC:</b> for SO <sub>2</sub> , NO <sub>2</sub> , O <sub>3</sub> , CO	Section 3.2.1	Each analyzer	Once per 2 weeks	O <sub>3</sub> Precision 7%, Bias ± 7%. <b>SO<sub>2</sub>, NO<sub>2</sub>, CO</b> Precision 10% , Bias ± 10%
<b>Annual performance evaluation</b> for SO <sub>2</sub> , NO <sub>2</sub> , O <sub>3</sub> , CO	Section 3.2.2	Each analyzer	Once per year	≤ 15 % for each audit concentration
<b>Flow rate verification</b> PM <sub>10</sub> , PM <sub>2.5</sub> , PM <sub>10-2.5</sub> , TSP	Section 3.2.3	Each sampler	Once every month	≤ 4% of standard and 5% of design value
<b>Semi-annual flow rate audit</b> PM <sub>10</sub> , PM <sub>2.5</sub> , PM <sub>10-2.5</sub> , TSP	Section 3.2.4	Each sampler	Once every 6 months	≤ 4% of standard and 5% of design value
<b>Collocated sampling</b> PM <sub>2.5</sub> , PM <sub>10-2.5</sub> , TSP	Section 3.2.5	15% within PQAQO	Every twelve days	PM <sub>2.5</sub> , - 10% precision PM <sub>10-2.5</sub> , - 15% precision TSP – 10% precision
<b>PM Performance evaluation program</b> PM <sub>2.5</sub> , PM <sub>10-2.5</sub>	Section 3.2.7	1. 5 valid audits for primary QA orgs, with ≤ 5 sites 2. 8 valid audits for primary QA orgs, with > 5 sites 3. All samplers in 6 years	over all 4 quarters	PM <sub>2.5</sub> , - ± 10% bias PM <sub>10-2.5</sub> , - ± 15% bias
<b>Manual Methods</b>				
<b>Collocated sampling</b> PM <sub>10</sub> , TSP, PM <sub>10-2.5</sub> , PM <sub>2.5</sub>	3.3.1 and 3.3.5	15% within PQAQO	Every 12 days PSD every 6 days	PM <sub>10</sub> , TSP, PM <sub>2.5</sub> , - 10% precision PM <sub>10-2.5</sub> , - 15% precision
<b>Flow rate verification</b> PM <sub>10</sub> (low Vol), PM <sub>10-2.5</sub> , PM <sub>2.5</sub> , TSP	3.3.2	Each sampler	Once every month	≤ 4% of standard and 5% of design value
<b>Flow rate verification</b> PM <sub>10</sub> (High-Vol), TSP	3.3.2	Each sampler	Once every quarter	≤ 10% of standard and design value
<b>Semi-annual flow rate audit</b> PM <sub>10</sub> (low Vol), PM <sub>10-2.5</sub> , PM <sub>2.5</sub> , TSP	3.3.3	Each sampler, all locations	Once every 6 months	≤ 4% of standard and 5% of design value
<b>Semi-annual flow rate audit</b> PM <sub>10</sub> (High-Vol), TSP	3.3.3	Each sampler, all locations	Once every 6 months	≤ 10% of standard and design value
<b>Manual Methods</b> Lead	3.3.4	1. Each sampler 2. Analytical (lead strips)	1. Include with TSP 2. Each quarter	1. Same as for TSP. 2. - ± 10% bias
<b>Performance evaluation program</b> PM <sub>2.5</sub> , PM <sub>10-2.5</sub>	3.3.7 and 3.3.8	1. 5 valid audits for primary QA orgs, with ≤ 5 sites 2. 8 valid audits for primary QA orgs, with ≥ 5 sites 3. All samplers in 6 years	Over all 4 quarters	PM <sub>2.5</sub> , ± 10% bias PM <sub>10-2.5</sub> , ± 15% bias

\* Some of the MQOs are found in CFR and others in Appendix D of this guidance document.

## 10.4 Use of Computers for Quality Control

With the wide range of economical computers now available, and the advancements in data acquisition system (DAS) technologies, consideration should be given to a computer system that can process and output the information in a timely fashion. Such a computer system should be able to:

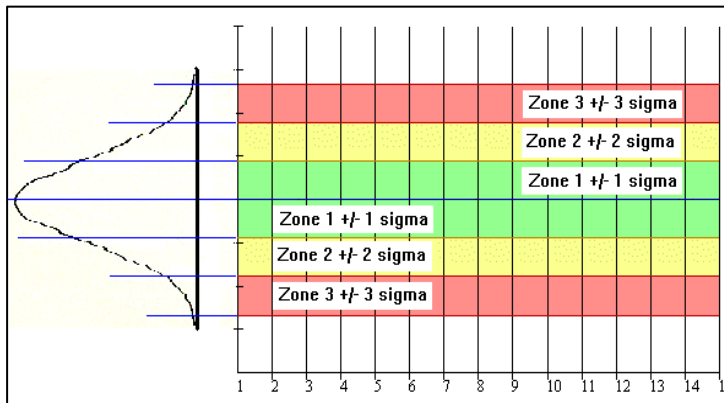

**Figure 10.2 Example Control Chart (courtesy of Six Sigma SPC see footnote)**

- compute calibration equations
- compute measures of linearity of calibrations (e.g., standard error or correlation coefficient)
- plot calibration curves
- compute zero/span drift results
- plot zero/span drift data
- compute precision and bias results
- compute control chart limits
- plot control charts<sup>3</sup>
- automatically flag out-of-control results
- maintain and retrieve calibration and performance records

Some of these checks (e.g., calibrations) only need to be reviewed as needed or when the actual check is performed. Other checks, like zero/span/one point QC checks or programmed routine data range or outlier checks that may occur every day are much more easily performed automatically by properly programmed computer systems. Earlier versions of this Handbook provided examples of quality control charts for zero and span drifts but with the advanced data acquisition system technologies available, the development of these charts is fairly straight forward.

Many vendors offering newer generation data loggers and ambient air information management systems provide programming of some of the QC checking capabilities listed above. EPA has also provided guidance and a Data Assessment Statistical Calculator (DASC) tool for the precision and bias calculations of the quality control checks required in CFR Part 58, Appendix A. In addition, the AMP 255 Report in AQS also provides these statistics for many of the QC samples described in Table 10-3 but use of these reports requires data reporting to AQS which does not usually occur in time frames needed for quality control.

<sup>3</sup> <http://www.sixsigmaspc.com/>

## 11.0 Instrument Equipment Testing, Inspection and Maintenance

Implementing an ambient air monitoring network, with the various types of equipment needed, is no easy task. Through appropriate testing, inspection and maintenance programs, monitoring organizations can be assured that equipment is capable of operating at acceptable performance levels. Every piece of equipment has an expected life span, and its use should be discontinued if its performance quality ceases to meet appropriate standards. For amortization purposes, EPA estimates a 7 year lifespan for most monitoring instruments and a somewhat longer lifespan for more permanent types of equipment (instrument racks, monitoring shelters etc.). This means that funds for replacing capital equipment are provided in resource allocations and monitoring organizations should make the best use of equipment replacement resources. Monitoring organizations may be able to prolong the life of equipment but in doing so they may run the risk of additional downtime, more upkeep and a greater chance of data invalidation, while losing out on newer technologies, better sensitivity/stability and the opportunities for better information management technologies.

Due to the many types of equipment that can be used in an ambient air monitoring program, this section provides general guidance on testing, inspection, and maintenance procedures for broad categories of equipment only. In most cases, equipment manufacturers include inspection and maintenance information in the operating manuals. The role of monitoring organizations, in developing a quality system, is to address the scheduling and documentation of routine testing, inspection, and maintenance. Detailed maintenance documents should be available for each monitoring site. Elements incorporated into testing, inspection and maintenance documents include:

- equipment lists - by organization and station;
- spare equipment/parts lists - by equipment, including suppliers;
- inspection/maintenance frequency - by equipment;
- testing frequency and source of the test concentrations or equipment;
- equipment replacement schedules;
- sources of repair - by equipment;
- service agreements that are in place; and
- monthly check sheets and entry forms for documenting testing, inspections and maintenance performed.

### 11.1 Instrumentation

#### 11.1.1 Analyzers and Samplers

Aside from the specific exceptions described in Appendix C of Part 58<sup>1</sup>, monitoring methods used for SLAMS monitoring must be a reference or equivalent method, designated as such by 40 CFR Part 53<sup>2</sup>. Reference or equivalent methods also must be used at NCore monitoring sites intended for comparison with any NAAQS. Among reference and equivalent methods, a variety of analyzer designs and features are available. For certain pollutants, analyzers employing different measurement principles are available. Some analyzer models only meet the minimum performance specifications (see Table 7-5), while others provide a higher level of performance. Section 7 provides information on what aspects to consider when selecting a particular monitoring instrument/analyzer. Upon receiving the new analyzer, the user should

---

<sup>1</sup> Code of Federal Regulations, Title 40, Part 58, Appendix C, U.S. Government Printing Office, 2006.

<sup>2</sup> Code of Federal Regulations, Title 40, Part 53, U.S. Government Printing Office, 2006.

carefully read the instructions or operating manual provided by the manufacturer. Information or instructions concerning the following should be found in the manufacturer's manual:

- unpacking and verifying that all component parts were delivered;
- checking for damage during shipment;
- checking for loose fittings and electrical connections;
- assembling the analyzer;
- installing the analyzer;
- calibrating the analyzer;
- operating the analyzer;
- electrical and plumbing diagrams;
- preventive maintenance schedule and procedures;
- troubleshooting; and
- a list of expendable parts.

Many vendors have specific time periods when the initial checks for damage in transit need to be made. The monitor should be assembled and set up according to the instructions in the manufacturer's manual. It may be important to do this initial set-up and testing at the main office or laboratory facility (see Section 11.1.3) before taking the equipment to the site. Following analyzer set-up, an initial verification of performance characteristics such as power flow, noise, and response time and a multi-point verification should be performed to determine if the analyzer is operating properly. These guidelines assume that the instrument was previously calibrated. If the instrument was disassembled after calibration, or no calibration of the instrument had previously been performed, the monitor must have a multi-point verification/calibration to ensure it is within acceptable calibration requirements prior to use. Short-term span, zero drift and precision should be checked during the initial calibration or measured using abbreviated forms of the test procedures provided in 40 CFR Part 53<sup>3</sup>. Acceptance of the analyzer should be based on results from these performance tests. Once accepted, reference and equivalent analyzers are guaranteed by the manufacturer to operate within the required performance specifications for one year<sup>4</sup>, unless major repairs are performed or parts are replaced. In such instances, the analyzers must be recalibrated before use.

### 11.1.2 Support Instrumentation

Experiences of monitoring organization staff; preventive maintenance requirements, ease of maintenance and general reliability play crucial roles in the selection of support equipment. The following examples depict general categories of support equipment and typical features to look for when selecting this equipment. This list is meant to guide agencies in the selection of equipment and does not represent required specifications.

- **Calibration Standards:** Calibration standards fall into several categories:
  - mass flow controlled (MFC) devices;
  - standards that meet the 1997 Traceability Protocol for Gaseous Calibration Standards<sup>5</sup>;
  - permeation devices;
  - photometers;

---

<sup>3</sup> Code of Federal Regulations, Title 40, Part 53, U.S. Government Printing Office, 2006.

<sup>4</sup> Code of Federal Regulations, Title 40, Part 53, U.S. Government Printing Office, 2006.

<sup>5</sup> EPA 600/R-97/121: Traceability Protocol for Gaseous Calibration Standards, September 1997

- flow measurement devices;
- water pressure measurement devices;
- barometric pressure measurement devices; and
- temperature measurement devices.

It is recommended that the devices be 110 VAC, be compatible with data acquisition systems for automated calibrations, and have digital compatibility or true transistor-transistor logic (TTL). The most common standards are MFC devices and permeation devices. Both use dilution air to obtain the needed output pollutant concentration.

- **Data Acquisition Systems (DAS):** DAS should have at least 32-bit logic for improved performance (DAS with at least 16-bit logic can still be used); have modem and internet capabilities; allow remote access and control; allow for digital input; and be able to initiate automated calibrations and polling. It is also recommended that DAS have software compatible with AQS and AQI reporting and editing. Both data loggers and analog chart recorders may be used for recording data; however, the storage, communicability, and flexibility of DAS coupled with data loggers makes the DAS systems the preferred option. More information on DAS is found in Section 14.
- **Instrument Racks:** Instrument racks should be constructed of steel and be able to accept sliding trays or rails. Open racks help to keep instrument temperatures down and allow air to circulate freely.
- **Instrument Benches:** Instrument benches should be of sufficient space to allow adequate room for multiple instruments with room to work and be capable of supporting a fair amount of weight (> 100 lbs). Slate or other hard, water-proof materials (e.g., steel) are recommended.
- **Zero Air Systems:** Zero air systems should be able to deliver 10 liters/min of air that is free of ozone, NO, NO<sub>2</sub>, and SO<sub>2</sub> to 0.001 ppm and CO and non-methane hydrocarbons to 0.1 ppm. There are many commercially available systems; however, simple designs can be obtained by using a series of canisters.

### 11.1.3 Laboratory Support

While it is not required, monitoring organizations should employ full laboratory facilities. These facilities should be equipped to test, repair, troubleshoot, and calibrate all analyzers and support equipment necessary to operate the ambient air monitoring network. In cases where individual laboratories are not feasible, a monitoring organization may be able to find a central laboratory where these activities can be performed.

It is recommended that the laboratory be designed to accommodate the air quality laboratory/shop and PM<sub>10</sub> and PM<sub>2.5</sub> filter rooms, as well as enforcement instrumentation support activities. The air quality portion consists of several benches flanked by instrument racks. One bench and rack are dedicated to ozone traceability. The other instrument racks are designated for calibration and repair. A room should be set aside to house spare parts and extra analyzers.

A manifold/sample cane should be mounted behind the bench. If possible, a sample cane that passes through the roof to allow analyzers that are being tested to sample outside air should be mounted to the

bench. This also allows any excess calibration gas to be exhausted to the atmosphere. It is recommended that the pump room be external to the building to eliminate noise.

Each bench area should have an instrument rack attached to the bench. The instrument rack should be equipped with sliding trays or rails that allow easy installation of instruments. If instrumentation needs to be repaired and then calibrated, this can be performed on the bench top or within the rack. Analyzers then can be allowed to warm up and be calibrated by a calibration unit. Instruments that are to be tested are connected to the sample manifold and allowed to sample air in the same manner as if the analyzer were being operated within a monitoring station. The analyzer is connected to an acquisition system (e.g., DAS, data logger, chart recorder, etc.) and allowed to operate. Any intermittent problems that occur can be observed on the data logger/chart recorder. The analyzer can be allowed to operate over several days to see if anomalies or problems reoccur; if they do, there is a record of them. If the instrument rack has a DAS and calibrator, nightly auto calibrations can be performed to see how the analyzer reacts to known gas concentrations. In addition, the ozone recertification bench and rack should be attached to a work bench. The rack should house the local ozone primary standard and the ozone transfer standards that are being checked for recertification. Zero air is plumbed into this rack for the calibration and testing of ozone analyzers and transfer standards.

## 11.2 Preventive Maintenance

Every monitoring organization should develop a preventive maintenance program. Preventive maintenance is what its name implies; maintaining the equipment within a network to prevent downtime and costly repairs and data loss. Preventive maintenance is an ongoing element of quality control and is typically enveloped into the daily routine. In addition to the daily routine, scheduled activities must be performed monthly, quarterly, semi-annually and annually.

Preventive maintenance is the responsibility of the station operators and the supervisory staff. It is important that the supervisor review the preventive maintenance work and continually check the schedule. The supervisor is responsible for making sure that preventive maintenance is being accomplished in a timely manner. Preventive maintenance is not a static process; procedures must be updated for many reasons, including, but not limited to, new models or types of instruments and new or updated methods. The preventive maintenance schedule is changed whenever an activity is completed or performed at an alternate time. For instance, if a multipoint calibration is performed in February instead of on the scheduled date in March, then the subsequent six-month calibration date moves from September to August. On a regular basis, the supervisor should review the preventive maintenance schedule with the station operators. Following all repairs, the instruments must be verified (multi-point) or calibrated.

Lists can facilitate the organization and tracking of tasks and improve the efficiency of preventive maintenance operations. A checklist of regular maintenance activities (e.g., periodic zero-span checks, daily routine checks, data dump/collection, calibrations, etc.) is recommended. A spare parts list, including relevant catalog numbers, is also recommended, as it facilitates the ordering of replacement parts. Such a list should be readily accessible and should include the types and quantities of spare parts already on-hand.

### 11.2.1 Station Maintenance

Station maintenance is an element of preventive maintenance that does not occur on a routine basis; rather, these tasks usually occur on an “as needed” basis. Station maintenance items are checked monthly or whenever an agency knows that the maintenance needs to be performed. Examples of station maintenance items include:

- floor cleaning;
- shelter inspection;
- air conditioner repair;
- AC filter replacement;
- weed abatement and grass cutting;
- roof repair;
- general cleaning;
- inlet and manifold cleaning;
- manifold exhaust blower lube;
- desiccant replacement; and
- ladder, safety rails, safety inspection, if applicable.

Simple documentation of these activities, whether in station logs or electronic logs, helps provide evidence of continuous attention to data quality.

### 11.2.2 Routine Operations

Routine operations are the checks that occur at specified periods of time during a monitoring station visit. These duties must be performed and documented in order to operate a monitoring network at optimal levels. Examples of typical routine operations are detailed in Table 11-1.

**Table 11-1 Routine Operation Checks**

Item	Each Visit	Weekly/Monthly	Minimum
Review Data	X		
Mark charts, where applicable	X		
Check/Oil Exhaust Blower	X		
Check Exterior		X	
Check/Change Desiccant	X		
Manifold Leak Test		X	
Inspect tubing	X		
Replace Tubing			Annually <sup>1</sup>
Inspect manifold and cane	X		
Clean manifold and cane			Every 6 months or as needed
Check HVAC systems		X	
Check electrical connections		X	
Field site supply inventory		X	

<sup>1</sup>If tubing is used externally as an inlet devices it may need to be replaced every 6 months or more frequently depending upon site specific issues.

In addition to these items, the exterior of the building, sample cane, meteorological instruments and tower, entry door, electrical cables, and any other items deemed necessary to check, should be inspected for wear, corrosion, and weathering. Costly repairs can be avoided in this manner.



### 11.2.3 Instrument and Site Logs

Each instrument and piece of support equipment (with the exception of the instrument racks and benches) should have an Instrumentation Repair Log (either paper or electronic). The log should contain the repair and calibration history of that particular instrument. Whenever multipoint calibration, instrument maintenance, repair, or relocation occurs, detailed notes are written in the instrumentation log. The log contains the most recent multipoint calibration report, a preventive maintenance sheet, and the acceptance testing information or reference to the location of this information. If an instrument is malfunctioning and a decision is made to relocate that instrument, the log travels with that device. The log can be reviewed by staff for possible clues to the reasons behind the instrument malfunction. In addition, if the instrument is shipped to the manufacturer for repairs, it is recommended that a copy of the log be sent with the instrument. This helps non-agency repair personnel with troubleshooting instrument problems. Improper recording of instrument maintenance can complicate future repair and maintenance procedures. The instrument log should be detailed enough to determine easily and definitively which instrument was at which sites over any given time period. If a problem is found with a specific instrument, the monitoring staff should be able to track the problem to the date it initially surfaced and invalidate data even if the instrument was used at multiple sites.

The site log is a chronology of the events that occur at the monitoring station. The log is an important part of station maintenance because it contains the narrative of past problems and solutions to those problems. Site log notes should be written in the form of a narrative, rather than shorthand notes or bulleted lists. Examples of items that should be recorded in the site log are:

- the date, time, and initials of the person(s) who have arrived at the site;
- brief description of the weather (e.g., clear, breezy, sunny, raining);
- brief description of exterior of the site. Any changes that might affect the data should be recorded – for instance, if someone is parking a truck or tractor near the site, this may explain high NO<sub>x</sub> values;
- any unusual noises, vibrations, or anything out of the ordinary;
- records of any station maintenance or routine operations performed;
- description of the work accomplished at the site (e.g., calibrated instruments, repaired analyzer); and
- detailed information about the instruments that may be needed for repairs or troubleshooting.

It is not required that the instrument and site logs be completely independent of each other. However, there is an advantage to having separate instrument logs. If instruments go in for repair, they may eventually be sent to another site. Having a separate instrument log allows the log to “travel” with the instrument. Keeping electronic instrument and station maintenance logs at stations and at centralized facilities (see LIMS discussion Section 8) also has record keeping advantages, but there needs to be a way that these records can be considered official and not be tampered with or falsified. Newer electronic signature technologies are helping ensure that electronic records can be considered official. It is important, however, that all of the required information for each instrument and site be properly recorded using a method that is comprehensive and easily understood. Many monitoring organizations have developed standard station maintenance forms that contain all the items to be checked and the frequency of those checks. It then becomes a very simple procedure to use this form to check off and initial the activities that were performed.

## 12.0 Calibrations

Calibration is defined as:

*the comparison of a measurement standard, instrument, or item with a standard or instrument of higher accuracy to detect and quantify inaccuracies and to report or eliminate those inaccuracies by adjustment<sup>1</sup>.*

Prior to the implementation of any ambient air monitoring activities, the sampling and analysis equipment must be checked to assure it is within calibration tolerances, and if it fails these tolerances, must be appropriately calibrated. This function is most routinely carried out at the field monitoring location.

Calibration of an analyzer or instrument establishes the quantitative relationship between an actual value of a standard, be it a pollutant concentration, a temperature, or a mass value (in ppm, °C or µg, etc.) and the analyzer's response (chart recorder reading, output volts, digital output, etc.). This relationship is used to convert subsequent analyzer response values to corresponding concentrations. Once an instrument's calibration relationship is established it is checked/verified at reasonable frequencies to verify that it remains in calibration.

### Verification Versus Calibration

Since the term calibration is associated with an adjustment in either the instrument or software, these adjustments should be minimized as much as possible. Sometimes performing frequent adjustments to provide the "most accurate data possible" can be self-defeating and be the cause of additional measurement uncertainty. Therefore, quality control procedures that include verification checks and multi-point calibration verifications are considered "checks without correction" and are used to ensure the instruments are within the calibration tolerances. Usually these tolerances have been developed so that as long as the instrument is within these tolerances, adjustments do not need to be made. However, verifications should be implemented at reasonable frequencies to avoid invalidating significant amounts of data.

**NOTE:** When the term "calibration" is used in the remainder of this section, it is assumed that multi-point verification is initially performed and the operator has concluded that calibration (adjustment) is necessary.

**NOTE:** EPA does not recommend post-processing of data to "correct" for data failing one point or multi-point verifications.

---

<sup>1</sup> American National Standard Quality Systems for Environmental Data and Technology Programs ANSI /ASQ E4 <http://www.asq.org/>

Each analyzer should be calibrated as directed by the analyzer's operation or instruction manual and in accordance with the general guidance provided here. For reference methods for CO, NO<sub>2</sub>, SO<sub>2</sub> and O<sub>3</sub>, detailed calibration procedures may also be found in the appropriate reference method Appendix in 40 CFR Part 50<sup>2</sup> and the method guidance and technical assistance documents listed in the fact sheets in Appendix A.

Calibrations should be carried out at the field monitoring site by allowing the analyzer to sample test atmospheres containing known pollutant concentrations. The analyzer to be calibrated should be in operation for at least several hours (preferably overnight) prior to the calibration so that it is fully warmed up and its operation has stabilized. During the calibration, the analyzer should be operating in its normal sampling mode, and it should sample the test atmosphere through all filters, scrubbers, conditioners, and other components used during normal ambient sampling and through as much of the ambient air inlet system as is practicable. All operational adjustments to the analyzer should be completed prior to the calibration (see section 12.7). Some analyzers can be operated on more than one range. For sites requiring the use of FRM or FEMs (NAAQS sites), the appropriate ranges are identified in the *Designated Reference and Equivalent Method List* found on AMTIC<sup>3</sup>. Analyzers that will be used on more than one range or that have auto-ranging capability should be calibrated separately on each applicable range.

Calibration documentation should be maintained with each analyzer and also in a central backup file. Documentation should be readily available for review and should include calibration data, calibration equation(s) (and curve, if prepared), analyzer identification, calibration date, analyzer location, calibration standards used and their traceability, identification of calibration equipment used, and the person conducting the calibration.

## 12.1 Calibration Standards and Reagents

Calibration standards are:

- Reagents of high grade
- Gaseous standards of known concentrations that are certified as EPA protocol gasses
- Instruments and or standards of high sensitivity and repeatability.

### 12.1.1 Reagents

In some cases, reagents are prepared prior to sampling. Some of these reagents will be used to calibrate the equipment, while others will become an integral part of the sample itself. In any case, their integrity must be carefully maintained from preparation through analysis. If there are any doubts about the method by which the reagents for a particular test were prepared or about the competence of the laboratory technician preparing them, the credibility of the ambient air samples and the test results will be diminished. It is essential that a careful record be kept listing the dates the reagents were prepared, by whom, and their locations at all times from preparation until actual use. Prior to the test, one individual should be given the responsibility of monitoring the handling and the use of the reagents. Each use of the reagents should be recorded in a field or lab notebook.

---

<sup>2</sup> <http://www.access.gpo.gov/nara/cfr/cfr-table-search.html>

<sup>3</sup> <http://www.epa.gov/ttn/amtic/criteria.html>

Chemical reagents, solvents, and gases are available in various grades. Reagents can be categorized into the following six grades<sup>4</sup>:

1. **Primary standard** - Each lot is analyzed, and the percentage of purity is certified.
2. **Analyzed reagents**- Can fall into 2 classes: (a) each lot is analyzed and the percentages of impurities are reported; and (b) conformity with specified tolerances is claimed, or the maximum percentages of impurities are listed.
3. **USP and NF Grade** - These are chemical reference standards where identity and strength analysis are ensured.
4. **“Pure,” “c.p.,” “chemically pure,” “highest purity”** - These are qualitative statements for chemicals without numerical meaning.
5. **“Pure,” “purified,” “practical grades”** - These are usually intended as starting substances for laboratory syntheses.
6. **Technical or commercial grades** - These are chemicals of widely varying purity.

The reference and equivalent methods define the grades and purities needed for the reagents and gases required in the Ambient Air Quality Monitoring Program.

All reagent containers should be properly labeled either with the original label or, at a minimum, the reagent, date prepared, expiration date, strength, preparer, and storage conditions. Leftover reagents used during preparation or analysis should never be returned to bottles.

### 12.1.2 Gaseous Standards

In general, ambient monitoring instruments should be calibrated by allowing the instrument to sample and analyze test atmospheres of known concentrations of the appropriate pollutant in air. The following is an excerpt from 50 CFR Part 58, Appendix A Section 2.6.1:

*“Gaseous pollutant concentration standards (permeation devices or cylinders of compressed gas) used to obtain test concentrations for carbon monoxide (CO), sulfur dioxide (SO<sub>2</sub>), nitrogen oxide (NO), and nitrogen dioxide (NO<sub>2</sub>) must be traceable to either a National Institute of Standards and Technology (NIST) Traceable Reference Material (NTRM) or a NIST-certified Gas Manufacturer’s Internal Standard (GMIS), certified in accordance with one of the procedures given in reference 4 of this appendix. Vendors advertising certification with the procedures provided in reference 4 of this appendix and distributing gasses as “EPA Protocol Gas” must participate in the EPA Protocol Gas Verification Program or not use “EPA” in any form of advertising.”*

"Traceable" is defined in 40 CFR Parts 50 and 58 as meaning that a local standard has been compared and certified, either directly or via not more than one intermediate standard, to a primary standard such as a National Institute of Standards and Technology Standard Reference Material (NIST SRM) or a USEPA/NIST-approved Certified Reference Material (CRM)". Normally, the working standard should be certified directly to the SRM or CRM, with an intermediate standard used only when necessary. Direct use of a CRM as a working standard is acceptable, but direct use of an NIST SRM as a working standard is discouraged because of the limited supply and expense of SRM's. At a minimum, the certification

---

<sup>4</sup> Quality Assurance Principles for Analytical Laboratories, 3rd Edition. By Frederick M. Garfield, Eugene Klesta, and Jerry Hirsch. AOAC International (2000). <http://www.aoac.org/>

procedure for a working standard should:

- establish the concentration of the working standard relative to the primary standard;
- certify that the primary standard (and hence the working standard) is traceable to a NIST primary standard;
- include a test of the stability of the working standard over several days; and
- specify a recertification interval for the working standard.

Table 12-1 suggests the requirements for the certification period for verification and calibration standards used in the ambient air program.

Certification of the working standard may be established by either the supplier or the user of the standard. As describe in CFR, gas supplier advertising “EPA Protocol Gas” will be required to participate in the EPA Protocol Gas Verification Program. Information on this program, including the gas supplier participating in the program, can be found on AMTIC<sup>5</sup>. EPA has developed procedures for the establishment of protocol gasses in the document: *EPA Traceability Protocol for Assay and Certification of Gaseous Calibration Standards*<sup>6</sup>.

Test concentrations of ozone must be traceable to a primary standard (see discussion of primary standards below) UV photometer as described in 40 CFR Part 50, Appendix D and the guidance document: *Transfer Standards for the Calibration of Ambient Air Monitoring Analyzers for Ozone*<sup>7</sup>.

Test concentrations at zero concentration are considered valid standards. Although zero standards are not required to be traceable to a primary standard, care should be exercised to ensure that zero standards are adequately free of all substances likely to cause a detectable response from the analyzer and at a minimum, below the lower detectable limit of the criteria pollutants being measured. Periodically, several different and independent sources of zero standards should be compared. The one that yields the lowest response can usually (but not always) be assumed to be the “best zero standard.” If several independent zero standards produce exactly the same response, it is likely that all the standards are adequate.

**Table 12-1 Certification Periods for Compressed Gas Calibration Standards in Aluminum Cylinders That Are Certified Under the EPA Protocol Gas Program**

Certified components	Balance gas	Applicable concentration range	Certification period (months)
Ambient nonmethane organics (15 components)	Nitrogen	5 ppb	24
Ambient toxic organics (19 components)	Nitrogen	5 ppb	24
Aromatic organic gases	Nitrogen	>0.25 ppm	36
Carbon dioxide	Nitrogen or air <sup>a</sup>	>300 ppm	36
Carbon monoxide	Nitrogen or air	>8 ppm	36
Hydrogen sulfide	Nitrogen	>4 ppm	12

<sup>5</sup> <http://www.epa.gov/ttn/amtic/>

<sup>6</sup> <http://www.epa.gov/ttn/emc/news.html>

<sup>7</sup> EPA-600/4-79-056. U.S. Environmental Protection Agency, Research Triangle Park, NC 27711. September 1979. <http://www.epa.gov/ttn/amtic/files/ambient/criteria/reldocs/4-79-056.pdf>

Certified components	Balance gas	Applicable concentration range	Certification period (months)
Methane	Nitrogen or air	>1 ppm	36
Nitric oxide	Oxygen-free nitrogen <sup>b</sup>	>4 ppm	24
Nitrous oxide	Air	>300 ppb	36
Oxides of nitrogen (i.e., sum of nitrogen dioxide and nitric acid)	Air	>80 ppm	24
Oxygen	Nitrogen	>0.8%	36
Propane	Nitrogen or air	>1 ppm	36
Sulfur dioxide	Nitrogen or air	40 to 499 ppm	24
Sulfur dioxide	Nitrogen or air	>500 ppm	36
Multicomponent mixtures	—	—	See text <sup>c</sup>
Mixtures with lower concentrations	—	—	See text

<sup>a</sup>When used as a balance gas, "air" is defined as a mixture of oxygen and nitrogen where the minimum concentration of oxygen is 10 percent and the concentration of nitrogen is greater than 60 percent.

<sup>b</sup>Oxygen-free nitrogen contains >0.5 ppm of oxygen.

<sup>c</sup>Text refers to Section 2 of EPA Protocol Gas Guidance Document

Certification periods decrease for concentrations below the applicable concentration ranges provide in Table 12-1. For example the certification period for SO<sub>2</sub> standards between 13-40 ppm is 6 months. Also, tank size may affect stability in low level standards. Some gas manufacturers claim that standards supplied in smaller tanks are stable for longer periods of time then the same concentration in larger tanks. Although this claim has not been verified if true it may be helpful in making purchasing decisions.

## Primary Reference Standards

A primary reference standard can be defined as a homogenous material with specific properties, such as identity, unity, and potency that has been measured and certified by a qualified and recognized organization<sup>8</sup>, such as the NIST SRMs. NIST also describes a Primary Reference Standard as a standard that is designated or widely acknowledged as having the highest metrological qualities and whose value is accepted without reference to other standards of the same quantity. For example, the NIST-F1 Atomic Clock<sup>9</sup>, is recognized as a primary standard for time and frequency. A true primary standard like NIST-F1 establishes maximum levels for the frequency shifts caused by environmental factors. By summing or combining the effects of these frequency shifts, it is possible to estimate the uncertainty of a primary standard without comparing it to other standards. NIST maintains a catalog of SRMs that can be accessed through the Internet<sup>10</sup>. Primary reference standards are usually quite expensive and are often used to calibrate, develop, or assay working or secondary standards. In order to establish and maintain NIST traceability the policies posted at the NIST Website<sup>11</sup> should be observed.

<sup>8</sup> Garfield, Frederick M. , "Quality Assurance Principles for Analytical Laboratories" Association of Official Analytical Chemists, Arlington VA, 1984

<sup>9</sup> <http://tf.nist.gov/timefreq/cesium/fountain.htm>

<sup>10</sup> <http://www.nist.gov>

<sup>11</sup> <http://ts.nist.gov/traceability/>

It is important that primary reference standards are maintained, stored, and handled in a manner that maintains their integrity. These samples should be kept under secure conditions and records should be maintained that document chain of custody information.

### 12.1.3 Instruments

The accuracy of various measurement devices in sampling and continuous instruments is very important to data quality. For example, in order to produce the correct flow rate to establish an accurate PM<sub>2.5</sub> cut point, the temperature and barometric pressure sensors, as well as the flow rate device, must be producing accurate measurements. Table 12-2 provides some of the more prevalent instruments that need to be calibrated at a minimum annually or when shown through various verification checks to be out of acceptable tolerances. In addition, the audit standards used to implement the checks and calibrations should be certified annually in order to establish their accuracy and traceability to higher standards (NIST).

**Table 12-2 Instruments and Devices Requiring Calibration and Certifications.**

Criteria	Acceptable Range	40 CFR Reference
<i>Verification/Calibration of devices in sampler/analyzer/laboratory against an authoritative standard</i>		
Barometric Pressure	± 10 mm Hg	Part 50, App.L, Sec 9.3
Temperature	± 2°C of standard	Part 50, App.L, Sec 9.3
Flow Rate	± 2% of transfer standard	Part 50, App.L, Sec 9.2
Design Flow Rate Adjustment	± 2% of design flow rate	Part 50, App.L, Sec 9.2.6
Clock/timer Verification	1 min/mo	Part 50, App.L, Sec 7.4
Mirobalance Calibration	Readability 1 µg Repeatability 1 µg	Part 50, App.L, Sec 8.1
<i>Verification/Calibration of devices in shelter or lab against an authoritative standard</i>		
Lab Temperature	± 2°C	not described
Lab Humidity	± 2%	not described
Mirobalance Calibration	Readability 1 µg Repeatability 1 µg	Part 50, App.L, Sec 8.1
<i>Verification/calibration standards requiring certification annually</i>		
Standard Reference Photometer (SRP)	±4% or ±4 ppb (whichever greater) RSD of six slopes ≤ 3.7%	not described
SRP recertification to local primary standard	Std. Dev. of 6 intercepts 1.5 New slope = ± 0.05% of previous	not described
Flow rate	± 2% of NIST –Traceable Standard	Part 50, App L Sec 9.2
Pressure	± 1 mm Hg resolution, ± 1 mm Hg accuracy	not described
Temperature	± 0.1°C of standard resolution, ± 0.5°C 1 mm Hg accuracy	not described
Gravimetric Standards	0.025 mg	not described

## 12.2 Multi-point Verifications/Calibrations

Multi-point calibrations consist of a zero and 4 upscale points, the highest being a concentration between 80 percent and 90 percent of the full scale range of the analyzer under calibration. Multi-point calibrations are used to establish or verify the linearity of analyzers upon initial installation, after major repairs and at specified frequencies. Most modern analyzers have a linear or very nearly linear response with concentration. If a non-linear analyzer is being calibrated, additional calibration points should be included to adequately define the calibration relationship, which should be a smooth curve. Calibration points should be plotted or evaluated statistically as they are obtained so that any deviant points can be investigated or repeated immediately.

Most analyzers have zero and span adjustment controls, which should be adjusted based on the zero and highest test concentrations, respectively, to provide the desired scale range within the analyzer's specifications (see section 12.5). For analyzers in routine operation, unadjusted ("as is") analyzer zero and span response readings should be obtained prior to making any zero or span adjustments. NO/NO<sub>2</sub>/NO<sub>x</sub> analyzers may not have individual zero and span controls for each channel; the analyzer's operation/instruction manual should be consulted for the proper zero and span adjustment procedure. Zero and span controls often interact with each other, so the adjustments may have to be repeated several times to obtain the desired final adjustments.

After the zero and span adjustments have been completed and the analyzer has been allowed to stabilize on the new zero and span settings, all calibration test concentrations should be introduced into the analyzer for the final calibration. The final, post-adjusted analyzer response readings should be obtained from the same device (chart recorder, data acquisition system, etc.) that will be used for subsequent ambient measurements. The analyzer readings are plotted against the respective test concentrations, and the best linear (or nonlinear if appropriate) curve to fit the points is determined. Ideally, least squares regression analysis (with an appropriate transformation of the data for non-linear analyzers) should be used to determine the slope and intercept for the best fit calibration line of the form,  $y = mx + a$ , where  $y$  represents the analyzer response,  $x$  represents the pollutant concentration,  $m$  is the slope, and  $a$  is the  $x$ -axis intercept of the best fit calibration line. When this calibration relationship is subsequently used to compute concentration measurements ( $x$ ) from analyzer response readings ( $y$ ), the formula is transposed to the form,  $x = (y - a)/m$ .

For the gaseous pollutants, the verification/calibration is considered acceptable if all calibration points fall within 2% of the full scale, best fit straight line. For manual samplers, devices (flow rate, temperature, pressure) are checked at different settings. Acceptance criteria for these devices can be found in the MQO Tables in Appendix D.

As a quality control check on calibrations, the standard error or correlation coefficient can be calculated along with the regression calculations. A control chart of the standard error or correlation coefficient could then be maintained to monitor the degree of scatter in the calibration points and, if desired, limits of acceptability can be established.



## 12.3 Frequency of Calibration and Analyzer Adjustment

An analyzer should be calibrated (or recalibrated):

- upon initial installation,
- following physical relocation,
- after any repairs or service that might affect its calibration,
- following an interruption in operation of more than a few days,
- upon any indication of analyzer malfunction or change in calibration, and
- at some routine interval (see below).

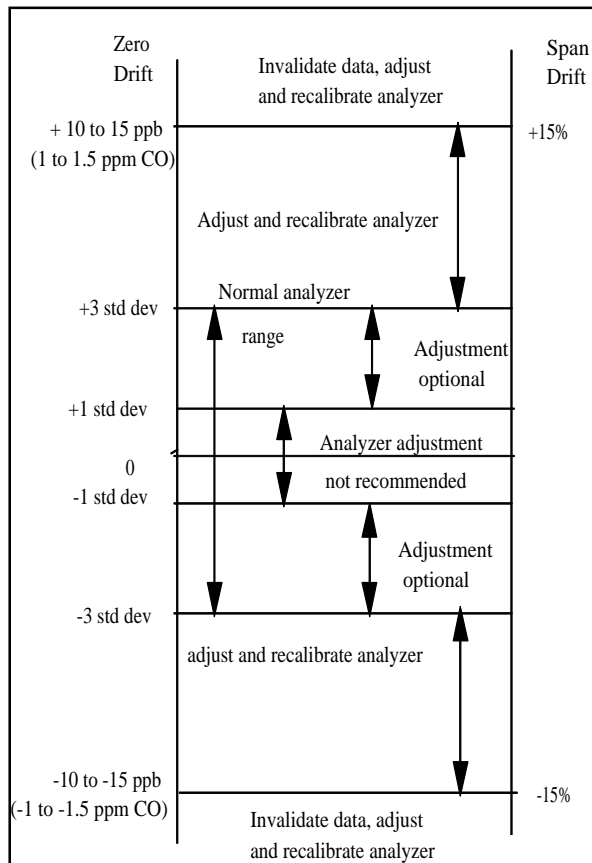

**Figure 12.1 Suggested zero/span drift limits**

When calibration relationships are applied to analyzer responses to determine actual concentrations, it is suggested that the analyzer be recalibrated periodically to maintain close agreement. The frequency of this routine periodic recalibration is a matter of judgment and is a tradeoff among several considerations, including: the inherent stability of the analyzer under the prevailing conditions of temperature, pressure, line voltage, etc., at the monitoring site; the cost and inconvenience of carrying out the calibrations; the quality of the ambient measurements needed; the number of ambient measurements lost during the calibrations; and the risk of collecting invalid data because of a malfunction or response problem with the analyzer that wouldn't be discovered until a calibration is carried out.

When a new monitoring instrument is first installed, zero/span and one point QC checks should be very frequent, perhaps daily or 3 times per week, because little or no information is available on the drift performance of the analyzer. With the advancement in data acquisition system technology, many monitoring organizations are running these QC checks daily. However, the QC checks are required to be implemented every two weeks.

Information on another unit of the same model

analyzer may be useful; however, individual units of the same model may perform quite differently. After enough information on the drift performance of the analyzer has been accumulated, the calibration frequency can be adjusted to provide a suitable compromise among the various considerations mentioned above.

To facilitate the process of determining calibration frequency, it is strongly recommended that control charts be used to monitor the zero/span and one-point QC drift performance of each analyzer. Control charts can be constructed in different ways, but the important points are to visually represent and statistically monitor drift, and to be alerted if the drift becomes excessive so that corrective action can be

taken. Such control charts make important use of the unadjusted zero and span response readings.

**NOTE:** Many newer technology analyzers have an “auto-zeroing” function incorporated in the instrument that can be implemented at user defined frequencies. Use of internal auto-zero functions typically does not need any post-processing of the data. EPA finds auto or manual zero adjustment acceptable, but does not recommend making automatic or manual adjustments (corrections) to the span until drift is unacceptable and warrants a calibration.

In continuous monitoring, the total cumulative drift, average of the absolute values of the individual drifts, and the standard deviation of the individual drifts should be calculated on a running basis over the last 100 or so days. Figure 12.1 summarizes some of the ranges and control chart limits that can be used to decide when calibration is warranted.

## 12.4 Adjustments to Analyzers

Ideally, all ambient measurements obtained from an analyzer should be calculated on the basis of the most current multipoint calibration or on the basis of both the previous and subsequent calibrations (see Section 12.5). Some acceptable level of drift (i.e., deviation from an original or nominal response curve) can be allowed before physical adjustments (a calibration) must be made because the calibration curve used to calculate the ambient measurements is kept in close agreement with the actual analyzer response. The chief limitations are the amount of change in the effective scale range of the analyzer that can be tolerated and possible loss of linearity in the analyzer's response due to excessive deviation from the design range. Cumulative drifts of up to 15 percent of full scale from the original or nominal zero and span values may not be unreasonable, subject to the limitations mentioned above.

Due to the advancement in monitoring technologies, ambient air monitors are much more stable and adjustments not as necessary. Earlier versions of this Handbook included sections for zero/span calibrations as well as physical zero/span adjustments. Precise adjustment of the zero and span controls may not be possible because of: (1) limited resolution of the controls, (2) interaction between the zero and span controls, and (3) possible delayed reaction to adjustment or a substantial stabilization period after adjustments are made. Precise adjustments may not be necessary because calibration of the analyzer following zero and span adjustments will define the precise response characteristic (calibration curve). EPA feels that frequent adjustments of instruments should not be necessary and may in fact lead to more data quality uncertainty. EPA does not recommend span adjustments be made between multi-point calibrations but zero adjustments are appropriate.

EPA is no longer including guidance suggesting that the calibration equation be updated after each zero/span check and suggests the ambient readings be calculated from the most recent multipoint calibration curve or from a fixed nominal or "universal" calibration curve (Section 12.5). In this case, the zero and span checks serve only to measure or monitor the deviation (drift error) between the actual analyzer response curve and the calibration curve used to calculate the ambient measurements.

### Automatic Self-Adjusting Analyzers

Some air monitoring analyzers are capable of periodically carrying out automatic zero and span calibrations and making their own zero and span self adjustments to predetermined readings. Automatic zero adjustments are considered reasonable, but EPA discourages the use of automatic span adjustments.

If the automatic zero standards pass through the sample inlet and sample conditioning system and both the adjusted and unadjusted zero response readings can be obtained from the data recording device, then the zero adjustment can be implemented.

## 12.5 Data Reduction Using Calibration Information

As noted previously, an analyzer's response calibration curve relates the analyzer response to actual concentration units of measure, and the response of most analyzers tends to change (drift) unpredictably with passing time. These two conditions must be addressed in the mechanism that is used to process the raw analyzer readings into final concentration measurements. Three practical methods are described below. They are listed in order of preference,

**1) "Universal" Calibration**--A fixed, "universal" calibration is established for the analyzer and used to calculate all ambient readings. All verifications and checks are used to measure the deviation of the current analyzer response from the universal calibration. Whenever this deviation exceeds the established zero and span adjustment limits, the analyzer is recalibrated.

**2) Major Calibration Update**--In this method, the calibration slope and intercept used to calculate ambient measurements are updated only for "major" calibration (i.e., semi-annual or annual multi-point verification/calibrations). All ambient measurements are calculated from the most recent major calibration. Between major calibrations, periodic zero and span calibrations are used to measure the difference between the most recent major calibration and the current instrument response. Physical or automated adjustments of the zero may be appropriate however span adjustment to restore a match between the current analyzer response and the most recent major calibration is not suggested. Whenever this deviation exceeds the established zero and span adjustment limits, the analyzer is recalibrated.

**3) Step-Change Update**-- the adjusted slope and intercept of the most recent calibration are used to calculate all subsequent ambient readings until updated by another calibration (i.e., no interpolation). No unadjusted zero or span readings are used, and ambient measurements can be calculated in real time if desired.

A significant problem with this method is acquiring the requisite calibration data and making sure they are merged correctly with the ambient data to facilitate the required calculations. Some automated data acquisition systems support this application by making special provisions to acquire and process periodic zero and span data. One way to ensure that the zero/span data are correctly merged with the ambient readings is to code the zero and span values directly into the data set at the location corresponding to the time of calibration, replacing the normal hourly reading that is lost anyway because of the calibration. These data can be marked (such as with a negative sign) to differentiate them from ambient data and later deleted from the final report printout. When zero and span data are acquired automatically by a data acquisition system for direct computer processing, the system must be sufficiently sophisticated to:

- ensure that zero or span data is never inadvertently reported as ambient measurements
- ignore transient data during the stabilization period before the analyzer has reached a stable zero or span response (this period may vary considerably from one analyzer to another)

- average the stable zero and span readings over some appropriate time period so that the zero or span reading obtained accurately represents the analyzers true zero or span response
- ignore ambient readings for an appropriate period of time immediately following a zero or span reading until the analyzer response has restabilized to the ambient-level concentration

## **12.6 Validation of Ambient Data Based on Calibration Information**

When zero or span drift validation limits (see Figure 12.1) are exceeded, ambient measurements should be invalidated back to the most recent acceptable zero/span/one-point QC check where such measurements are known to be valid. Also, data following an analyzer malfunction or period of non-operation should be regarded as invalid until the next subsequent calibration unless unadjusted zero and span readings at that calibration can support its validity.

### **Documentation**

All data and calculations involved in these calibration activities should be recorded in the instrument log book described in Section 11.

## 13.0 Inspection/Acceptance for Supplies and Consumables

Both field operations and laboratory operations need supplies and consumables. The focus of this section is the management of laboratory and field sampling supplies and consumables. For information on the actual field/lab supplies and consumables needed for any specific method, see the reference method in 40 CFR Part 50<sup>1</sup>, the general guidance methods and technical assistance documents on AMTIC<sup>2</sup> and the manufacturer's operations manuals. From this information, monitoring organizations, as part of the QAPP requirements, will develop specific SOPs for its monitoring and analytical methods. One section of the SOPs requires a listing of the acceptable supplies and consumables for the method.

Pollutant parameters are measured using electronic (e.g., continuous emission monitors, FTIRs, etc...), wet chemical techniques, or physical methods. Chemical analysis always involves the use of consumable supplies that must be replaced on a schedule consistent with their stability and with the rate at which samples are taken. Currently used physical methods require adequate supplies of chemicals for operation for three months so that the supplier can comply with the delivery schedules. In some cases, analytical reagents for specific air contaminants deteriorate rapidly and need protective storage. The following information may be helpful when considering the use of these consumable items. Much of the information presented below is derived from the document *Quality Assurance Principles for Analytical Laboratories*<sup>3</sup>.

### 13.1 Supplies Management

Control of supplies and consumables is important to the success of the quality assurance program. It is important that specifications for each item are prepared and adhered to during the procurement process. When specifications are prepared, the following points should be considered: identity, purity, potency, source, tests to be conducted for quality and purity, need for further purification, storage and handling procedures, and replacement dates. As part of supplies management, the following actions are recommended:

- establish criteria and specifications for the important supplies and consumables.
- check and test the supplies and consumables against specifications, before placing them in use.
- design and maintain a supplies management program to ensure the quality of reagents used in day-to-day operations, paying particular attention to primary reference standards, working standards, and standard solutions.
- decide on the kinds of purified water that are necessary, and develop suitable tests and testing intervals to ensure the quality of water used in analytical work and for cleaning glassware.
- purchase only Class A volumetric glassware and perform calibrations and recalibrations that are necessary to achieve reliable results.
- establish procedures for cleaning and storing glassware/sample containers with due consideration for the need for special treatment of glassware/sample containers used in trace analysis.
- establish a useful life for glassware/sample containers and track this.
- discard chipped and etched glassware or damaged containers.

---

<sup>1</sup> <http://www.access.gpo.gov/nara/cfr/cfr-table-search.html>

<sup>2</sup> <http://www.epa.gov/ttn/amtic/>

<sup>3</sup> Quality Assurance Principles for Analytical Laboratories, 3rd Edition. By Frederick M. Garfield, Eugene Klesta, and Jerry Hirsch. AOAC International (2000). <http://www.aoac.org/>

## 13.2 Standards and Reagents

Discussions on gaseous standards and reagents are discussed in Section 12. What is most important is that the standards and reagents used are of appropriate purity and certified within the acceptable limits of the program for which they are used. Table 12-1 provides certification frequencies for gaseous standards, but within these timeframes, and as new cylinders are purchased, monitoring organizations need to develop a standard checking scheme to establish ongoing acceptance of standards. For example a new SRM should be purchased months prior to the expiration (or need for recertification) or complete use of an older standard in order to develop an overlapping cylinder acceptance process so there is some establishment of traceability and consistency in monitoring. For example, if a new SRM is put into use in a monitoring organization and all monitoring instruments traced to the cylinder start failing calibration, it may mean that either the new or older cylinder was not properly certified or has integrity problems. By checking both cylinders prior to new cylinder use, this issue can be avoided.

### 13.2.1 Standard Solutions

Most laboratories maintain a stock of standard solutions. The following information on these solutions should be kept in a log book:

- identity of solution
- strength
- method of preparation (reference to SOP)
- standardization calculations
- recheck of solution for initial strength
- date made/expiration date
- initials of the analyst
- storage

As mentioned above, all standard solutions should contain appropriate labeling as to contents and expiration dates.

### 13.2.2 Purified Water

Water is one of the most critical but most often forgotten reagent. The water purification process should be documented from the quality of the starting raw water to the systems used to purify the water, including how the water is delivered, the containers in which it is stored, and the tests and the frequency used to ensure the quality of the water.

## 13.3 Volumetric Glassware

Use of the appropriate glassware is important since many preparations and analyses require the development of reagents, standards, dilutions, and controlled delivery systems. It is suggested that "Class A" glassware be used in all operations requiring precise volumes. SOPs requiring volumetric glassware should specify the size/type required for each specific operation.

## 13.4 Sample Containers

Samples may be contaminated by using containers that have not been properly cleaned and prepared (e.g., VOC canisters, particulate filter cassettes/containers) or purchased from vendors without proper inspection prior to use. In addition, all sample containers have a “useful” life. Some containers, such as the low volume PM sample filter cassettes can be damaged over time and cause leaks in the sampling system. It is important to track the inventory of sampling containers from:

- date of purchase;
- first use;
- frequency of use (estimate);
- time of retirement.

An inventory of this type can help ensure new containers are purchased prior to old ones expiring and/or causing sample integrity problems. Use of appropriate sample containers is important since the material of the container could potentially affect the collected sample. Always refer to the specific method to see if a particular type of container (e.g., high density polyethylene [HDPE] bottles, amber glass) is required for the storage of the sample.

## 13.5 Particulate Sampling Filters

Filters are used for the manual methods for criteria pollutants (e.g., PM<sub>10</sub>, PM<sub>2.5</sub>, PM<sub>10-2.5</sub>, total PM, Pb, etc...). No commercially available filter is ideal in all respects. The sampling program should determine the relative importance of certain filter evaluation criteria (e.g., physical and chemical characteristics, ease of handling, cost). The reference methods provide detailed acceptance criteria for filters. Some of the basic criteria that must be met regardless of the filter type follows:

- **Visual inspection** - for pinholes, tears, creases, or other flaws that may affect the collection efficiency of the filter, which may be consistent through a batch. This visual inspection would also be made prior to filter installation and during laboratory pre- and post-weighings to assure the integrity of the filter is maintained and, therefore, the ambient air sample obtained with each filter adequately represents the sampled pollutant conditions.
- **Collection efficiency** - greater than 99% as measured by DOP test (ASTM 2988) with 0.3 micrometer particles at the sampler's operating face velocity.
- **Integrity** - (pollutant specific) measured as the concentration equivalent corresponding to the difference between the initial and final weights of the filter when weighed and handled under simulated sampling conditions (equilibration, initial weighing, placement on inoperative sampler, removal from a sampler, re-equilibration, and final weighing).
- **Alkalinity** - less than 0.005 milliequivalent/gram of filter following at least two months of storage at ambient temperature and relative humidity.

**Note:** Some filters may not be suitable for use with all samplers. Due to filter handling characteristics or rapid increases in flow resistance due to episodic loading, some filters, although they meet the above criteria, may not be compatible with the model of sampler chosen. It would be prudent to evaluate more than one filter type before purchasing large quantities for network use. In some cases, EPA Headquarters may have national contracts for acceptable filters that will be supplied to monitoring organizations.

## 13.6 Field Supplies

Field instrumentation, which includes samplers and analyzers, require supplies for the actual collection process as well as quality control activities and crucial operational maintenance. These supplies can include, but are not limited to:

- Gas standards/Permeation standards
- HVAC units
- Maintenance equipment (tools, ladders)
- Safety supplies (first aid kit)
- Information technology supplies (PC, printers, paper, ink, diskettes)
- Sample line filters
- Charcoal
- Desiccant
- Gaskets and O-rings
- Sample lines and manifolds
- Disposable gloves
- Water/distilled water
- Pumps and motors
- Chart paper and ink
- Impaction oil
- TEOM FDMS filter

The site logbook discussed in Section 11 should include a list and inventory of these critical field supplies. As part of routine maintenance activities, this inventory can be reviewed to determine if any supplies are in need of restocking.



## 14.0 Data Acquisition and Information Management

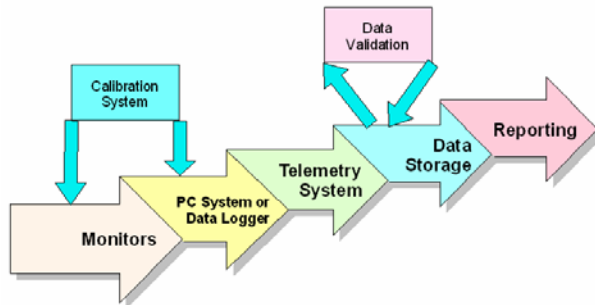

Success of the Ambient Air Quality Program objectives relies on data and its correct interpretation. It is critical that data be available to users and that these data are:

- reliable;
- of known quality;
- easily accessible to a variety of users; and
- aggregated in a manner consistent with its prime use

In order to accomplish this activity, information must be collected and managed in a manner that protects and ensures its integrity.

Most of the data collected from the Ambient Air Monitoring Program will be collected through automated systems at various facilities. These systems must be effectively managed by using a set of guidelines and principles by which adherence will ensure data integrity. The EPA has a document entitled Good Automated Laboratory Practices (GALP)<sup>1</sup>. The GALP defines six data management principles:

- 1. DATA: The system must provide a method of assuring the integrity of all entered data. Communication, transfer, manipulation, and the storage/recall process all offer potential for data corruption. The demonstration of control necessitates the collection of evidence to prove that the system provides reasonable protection against data corruption.*
- 2. FORMULAE: The formulas and decision algorithms employed by the system must be accurate and appropriate. Users cannot assume that the test or decision criteria are correct; those formulas must be inspected and verified.*
- 3. AUDIT: An audit trail that tracks data entry and modification to the responsible individual is a critical element in the control process. The trail generally utilizes a password system or equivalent to identify the person or persons entering a data point, and generates a protected file logging all unusual events.*
- 4. CHANGE: A consistent and appropriate change control procedure capable of tracking the system operation and application software is a critical element in the control process. All software changes should follow carefully planned procedures, including a pre-install test protocol and appropriate documentation update.*
- 5. STANDARD OPERATING PROCEDURES (SOPs): Control of even the most carefully designed and implemented systems will be thwarted if appropriate procedures are not followed. The principles implies the development of clear directions and Standard Operating Procedures (SOPs); the training of all users; and the availability of appropriate user support documentation.*
- 6. DISASTER: Consistent control of a system requires the development of alternative plans for system failure, disaster recovery, and unauthorized access. The control principle must extend to planning for reasonable unusual events and system stresses.*

<sup>1</sup> <http://www.epa.gov/irmpoli8/ciopolicy/2185.pdf>

The principles listed above apply to both the local and central information management systems. The ambient pollutant data generated by gas analyzers or manual samplers must be captured, organized, and verified in order to be useful. The process of capturing the data is known as data acquisition. The organization of the data is known as data management. This section provides guidance in these areas, including identification of advanced equipment and procedures that are recommended for implementation. The recommended procedures rely on digital communication by the data acquisition system to collect a wider variety of information from the analyzers, to control instrument calibrations, and to allow for more routine, automated, and thorough data quality efforts. The section will discuss:

1. **Data acquisition-** collecting the raw data from the monitor/sampler, storing it for an appropriate interval, aggregating or reducing the data, and transferring this data to final storage in a local data base (monitoring organizations database)
2. **Data transfer-** preparing and moving data to external data bases such as AIRNow or the Air Quality System (AQS).
3. **Data management-** ensuring the integrity of the data collection systems

In response to guidelines issued by the Office of Management and Budget (OMB) under Section 515(a) of the Treasury and General Government Appropriations Act for Fiscal Year 2001 (Public Law 106-554; H.R. 5658), EPA developed the document titled *Guidelines for Ensuring and Maximizing the Quality, Objectivity, Utility, and Integrity of Information Disseminated by the Environmental Protection Agency*<sup>2</sup>. The Guideline contains EPA's policy and procedural guidance for ensuring and maximizing the quality of information it disseminates. The Guideline also incorporates the following performance goals:

- Disseminated information should adhere to a basic standard of quality, including objectivity, utility, and integrity.
- The principles of information quality should be integrated into each step of EPA's development of information, including creation, collection, maintenance, and dissemination.
- Administrative mechanisms for correction should be flexible, appropriate to the nature and timeliness of the disseminated information, and incorporated into EPA's information resources management and administrative practices.

EPA suggests monitoring organizations review this document since it is relevant to the ambient air information it generates and can help to ensure that data can withstand challenges to its quality.

## 14.1 Data Acquisition

Data acquisition technology is advancing and ever changing. Computer systems are now available in most air quality instruments. This has changed data acquisition in a profound way; most data is available in an instantaneous digital format from the instrument. This can be a powerful tool to quickly recognize and mitigate data quality problems. These digital systems should increase data capture and reporting. On the other hand, this increase in instantaneous data can be overwhelming if the monitoring organization is not prepared. The timely reporting of high quality, highly time-resolved ambient monitoring data will require a coordinated effort to ensure data management systems are meeting desired performance needs. These data management systems will need to provide validated data, to the extent possible, in near real time to multiple clients within minutes from the end of a sample period. Data management systems used

---

<sup>2</sup> [http://www.epa.gov/quality/informationguidelines/documents/EPA\\_InfoQualityGuidelines.pdf](http://www.epa.gov/quality/informationguidelines/documents/EPA_InfoQualityGuidelines.pdf)

in ambient air monitoring will need to provide efficient processing and validation of data, and provide appropriate communication of that data in a format appropriate and available for multiple users. As an example, improved data management systems from all NCore continuous monitors can provide near real-time, high quality, hourly data during episodes. This will allow technical and policy staff to better understand the exposure and interactions of air pollutants in the atmosphere of most interest. This section provides information on Data Acquisition Systems (DAS), a term used for systems that collect, store, summarize, report, print, calculate or transfer data. The transfer is usually from an analog or digital format to a digital medium. This section will also discuss limitations of data collected with DAS.

### **14.1.1 Automated Data Acquisition Requirements**

DAS have been available to air quality professionals since the early 1980s. The first systems were single and multi-channel systems that collected data on magnetic media. This media was usually hand transferred to a central location or laboratory for downloading to a central computer. With the advent of digital data transfer from the stations to a central location, the need to hand transfer data has diminished. However, errors in data reporting can occur with digital data. For DAS, there are two sources of error between the instrument (sensor) and the recording device: 1) the output signal from the sensor, and 2) the errors in recording by the data logger. For DAS that collect digital meta and reported data, these are not issues. Digital transfer of data does not suffer from the same problems as digital to analog transfer. When one digital device sends digital signals, the data is sent in data package streams that are coded then decoded at the receiving end. This digital transfer does not suffer from signal degradation. Most automated data acquisition systems support the acquisition of QC data like zero, one point QC and span data. One way to ensure that the QC data are correctly merged with the ambient readings is to code the QC values directly into the data set at the location corresponding to the time of the checks, replacing the normal hourly reading that is lost anyway because of the check. These data can be marked or flagged to differentiate it from ambient data and later deleted from the final routine data report printout. When QC data is acquired automatically by a data acquisition system for direct computer processing, the system must be sufficiently sophisticated to:

- ensure that the QC data is never inadvertently reported as ambient measurements,
- ignore transient data during the stabilization period before the analyzer has reached a stable QC response (this period may vary considerably from one analyzer to another),
- average the stable QC readings over some appropriate time period so that the readings obtained accurately represents the analyzer's QC response,
- ignore ambient readings for an appropriate period of time immediately following a QC reading until the analyzer response has restabilized to the ambient-level concentration.

### **14.1.2 Instrument to Data logger**

Figure 14.1 shows the basic transfer of data from the instrument to the final product; a hard copy report, or data transfer to a central computer. Most continuous monitors have the ability to output data in at least two ways: analog output and an RS232 digital port. Some instrumentation may now be including USB, Ethernet and firewire capability. The instrument has a voltage potential that generally is a DC voltage. This voltage varies directly with the concentration collected. Most instruments' output is a DC voltage in the 0-1 or 0-5 volts range. The following provide a brief summary of the analog (A) or digital (D) steps

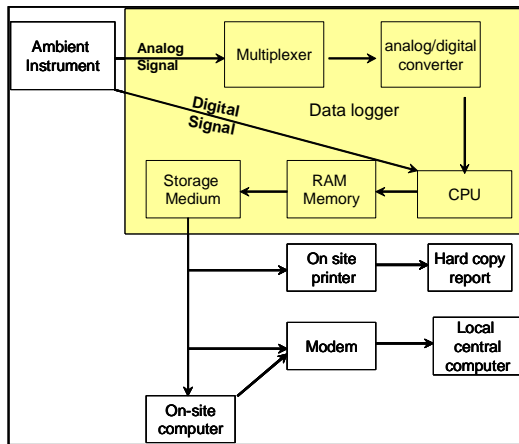
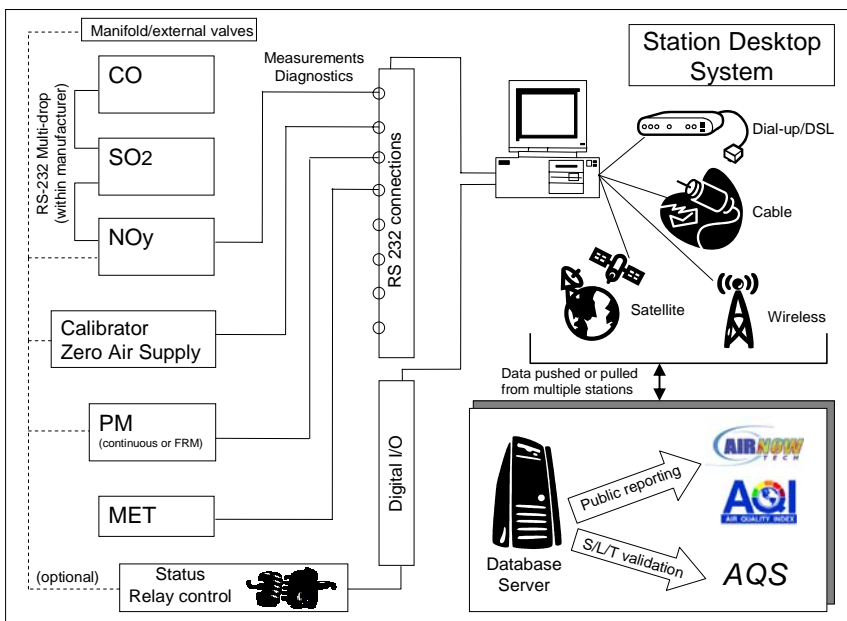

**Figure 14.1 DAS data flow**

- (A) the voltage is measured by the multiplexer which allows voltages from many instruments to be read at the same time.
- (A) the multiplexer sends a signal to the a/d converter which changes the analog voltage to a low amperage digital signal.
- (A) the a/d converter send signals to the central processing unit (cpu) that directs the digital electronic signals to a display or to the random access memory (ram) which stores the short-term data until the end of a pre-defined time period.
- (A/D) the cpu then shunts the data from the ram to the storage medium which can be magnetic tape, computer hard-drive or computer diskette.
- (A/D) the computer storage medium can be accessed remotely or at the monitoring location.

The data transfer may occur via modem to a central computer storage area or printed out as hard copy. In some instances, the data may be transferred from one storage medium (i.e. hard drive to a diskette, tape, or CD) to another storage medium. The use of a data logging device to automate data handling from a continuous sensor is not a strict guarantee against recording errors. Internal validity checks are necessary to avoid serious data recording errors.

### Analog Versus Digital DAS -



**Figure 14.2 Flow of data from gas analyzers to final reporting**

Most analyzers built within the last 15 years have the capability (RS232 ports) to transfer digital signals, yet many monitoring organizations currently perform data acquisition of automated monitors by recording an analog output from each gas analyzer using an electronic data logger. As explained above, the analog readings are converted and stored in digital memory in the data logger for subsequent automatic retrieval by a remote data management system. This approach can reliably capture the monitoring data, but does not

allow complete control of monitoring operations, and the recorded analog signals are subject to noise that limits the detection of low concentrations. Furthermore, with the analog data acquisition approach, the data review process is typically labor-intensive and not highly automated. For these reasons, EPA

encourages the adoption of digital data acquisition methods. In that regard, the common analog data acquisition approach often does not fully utilize the capabilities of the electronic data logger. Many data loggers have the capability to acquire data in digital form and to control some aspects of calibrations and analyzer operation, but these capabilities are not utilized in typical analog data acquisition approaches.

Digital data acquisition reduces noise in the recording of gas monitoring data, thereby improving sensitivity. It also records and controls the instrument settings, internal diagnostics, and programmed activities of monitoring and calibration equipment. Such data acquisition systems also typically provide automated data quality assessment as part of the data acquisition process.

It may be cost-effective for monitoring organizations to adopt digital data acquisition and calibration control simply by more fully exploiting the capabilities of their existing electronic data loggers. For example, many gas analyzers are capable of being calibrated under remote control. The opportunity to reduce travel and personnel costs through automated calibrations is a strong motivator for monitoring organizations to make greater use of the capabilities of their existing data acquisition systems. The NCore multi-pollutant sites are taking advantage of the newer DAS technologies. Details of these systems can be found in the technical assistance document for this program<sup>3</sup>.

Figure 14.2 illustrates the recommended digital data acquisition approach for the NCore sites. It presents the data flow from the gas monitors, through a local digital data acquisition system, to final reporting of the data in various public databases. This schematic shows several of the key capabilities of the recommended approach. A basic capability is the acquisition of digital data from multiple analyzers and other devices, thereby reducing noise and minimizing the effort needed in data processing. Another capability is two-way communication, so that the data acquisition system can interrogate and/or control the local analyzers, calibration systems, and even sample inlet systems, as well as receive data from the analyzers. Data transfer to a central location is also illustrated, with several possible means of that transfer shown. Monitoring organizations are urged to take advantage of the latest technology in this part of the data acquisition process, as even technologies such as satellite data communication are now well established, commercially available, and inexpensive to implement for monitoring operations.

Depending on the monitoring objective, it may be important that data are reported in formats of immediate use in public data bases such as AQS<sup>4</sup>, and the multi-monitoring organization AIRNow<sup>5</sup> sites. An advantage of DAS software is the ability to facilitate the assembly, formatting and reporting of monitoring data to these databases.

Digital data acquisition systems such as those in Figure 14.2 offer a great advantage over analog systems in the tracking of calibration data, because of the ability to control and record the internal readings of gas analyzers and calibration systems. That is, a digital data acquisition system not only can record the analyzer's output readings, but can schedule and direct the performance of analyzer calibrations, and record calibrator settings and status. Thus, flagging of calibration data to distinguish them from ambient monitoring data is conducted automatically during data acquisition with no additional effort or post-analysis. These capabilities greatly reduce the time and effort needed to organize and quantify calibration results.

---

<sup>3</sup> Version 4 of the Technical Assistance Document for Precursor Gas Measurements in the NCore Multi-pollutant Monitoring Network. <http://www.epa.gov/ttn/amtic/pretecdoc.html>

<sup>4</sup> <http://www.epa.gov/ttn/airs/airsaqs/aqsweb/>

<sup>5</sup> <http://airnow.gov/>

### 14.1.3 DAS Quality Assurance/Quality Control

Quality assurance aspects of the DAS deal with whether the system is being operated within defined guidelines. Usually, this means that each value that is collected on the DAS is the same value that is generated from the analyzer and reported to the Air Quality System (AQS) data base. This usually is accomplished by calibrations, data trail audits and performance audits.

**Calibration-** In the case where analog signals from monitoring equipment are recorded by the DAS, the calibration of a DAS is similar to the approach used for calibration of a strip chart recorder. To calibrate the DAS, known voltages are supplied to each of the input channels and the corresponding measured response of the DAS is recorded. Specific calibration procedures in the DAS owner's manual should be followed when performing such DAS calibrations. For DAS that receive digital data from the instruments, a full scale check (the instrument is in a mode and the output is at the full scale of the instrument) should be performed to see if the data received digitally is the same as the display of the instrument. The DAS should be calibrated at least once per year. Appendix G provides a simple approach for calibration of the DAS.

In addition, gas analyzers typically have an option to set output voltages to full scale or to ramp the analog output voltages supplied by the analyzer over the full output range. Such a function can be used to check the analog recording process from the analyzer through the DAS.

**Data Trail Audit-** The data trail audit consists of following a value or values collected by the DAS to the central data collection site and then eventually to AQS. A person other than the normal station operator should perform this duty. The following procedure should be followed:

- A data point should be collected from the DAS (usually an hourly value or another aggregated value reported to AQS) and be checked on the DAS storage medium against the hard copy report. Also if strip chart recorders are used, a random number of hourly values should be compared to the data collected by the DAS. This audit should be completed on a regular defined frequency and for every pollutant reported.
- From the central computer, the auditor checks to see if this hourly value is the same.

The above actions should be completed well in advance of data submittal to AQS. If the data has been submitted to AQS, then the AQS data base should be checked and modified as necessary per the appropriate AQS procedures.

Whether a monitoring organization is transferring the data from an instrument via an on-site DAS or transferring the data digitally, the data trail audit should be performed on a routine basis.

**Performance Audit-** The performance audit consists of challenging the instrument and DAS to a known audit source gas and observing the final response. The response should correspond to the value of the audit source gas. Section 15 discusses these performance audits.

#### Initialization Errors

All data acquisition systems must be initialized. The initialization consists of an operator "setting up" the parameters so that the voltages produced by the instruments can be read, scaled correctly and reported in the correct units. Errors in initializations can create problems when the data is collected and reported. Read the analyzer manufacturer's literature before parameters are collected. If the manufacturer does not

state how these parameters are collected, request this information. The following should be performed when setting up the initializations:

- Check the full scale outputs of each parameter.
- Calibrations should be followed after each initialization (each channel of a DAS should be calibrated independently). Appendix G provides an example of a DAS calibration technique.
- Review the instantaneous data stream, if possible, to see if the DAS is collecting the data correctly.
- Save the initializations to a storage medium; if the DAS does not have this capability, print out the initialization and store it at the central computer location and at the monitoring location.
- Check to see if the flagging routines are performed correctly; data that are collected during calibrations and down time should be flagged correctly.
- Check the DAS for excessive noise (variability in signal). Noisy data that are outside of the normal background are a concern. Noisy data can be caused by improperly connected leads to the multiplexer, noisy AC power, or a bad multiplexer. Refer to the owner's manual for help on noisy data.
- Check to see that the average times are correct. Some DAS consider 45 minutes to be a valid hour, while others consider 48 minutes. Agency guidelines should be referred to before setting up averaging times.

#### 14.1.4 Data Logger to Database

Once data are on the data logger at the ambient air monitoring station, they need to be sent to servers where they can be summarized and disseminated to data users. In most cases this will occur by using a server at the office of the monitoring organization. The conventional way to get data from the monitoring stations has been to poll each of the stations individually. With more widespread availability of the internet, pushing data from monitoring sites on a regular basis will be especially effective in mapping and public reporting of data. Note, in some cases it is possible to report data directly from a monitor to a database without the use of a station data logger. This solution is acceptable so long as the monitor is capable of data storage for periods when telemetry is off-line.

Data transfer is usually accomplished in three ways: hard copy printout, downloading data from internal storage medium to external storage medium, or digital transfer via the telephone lines, internet, satellite or other advanced means of communication. Due to the desire for real time data for the Air Quality Index (AQI) and other related needs, monitoring organizations should plan to upgrade to digital data acquisition and communication systems.

**Hard copy report-** Most DAS have the ability to create a hard copy report. Usually, this report is in tabular format showing 1 minute, 5 minute or hourly averages. Monitoring organization are encouraged to keep hard copy printouts for several reasons:

- they can be reviewed by the station operators prior to and/or during site visits to ascertain the quality of the data;
- they can be compared against the historical data stored on the DAS at the site for validation;
- notes can be made on the hard copy reports for later review by data review staff; and
- they create a "back-up" to the electronically based data.

**NOTE:** It is strongly recommended that monitoring organizations create an electronic back-up of their data on a defined schedule. The frequency of the back-ups and any other associated

information should be reflected in their Quality Assurance Project Plan (QAPP) and Standard Operating Procedures (SOP).

**External Storage-** This term refers to storing and transferring the data on diskettes or CD. Many new generation DAS are computer platforms. The newer generation computers generally have the ability to download data to CD or zip drive. If remote access via telephone is not an option, then data can be hand transferred to a central office for downloading and data review.

**Digital Transfer-** All new generation DAS allow access to the computer via the telephone and modem. These systems allow fast and effective ways to download data to a central location. The EPA recommends using these systems for the following reasons:

- in case of malfunction of an ambient instrument, the appropriate staff at the central location can begin to diagnose problems and decide a course of action;
- down loading the data allows the station operators, data processing team, and/or data validators to get a head start on reviewing the data; and
- when pollution levels are high or forecasted to be high, digital transfer allows the pollution forecaster the ability to remotely check trends and ensure proper operation of instruments prior to and during an event.

#### 14.1.5 DAS Data Review

The data review is an ongoing process that is performed by the station operators (SO) and the data processing team (DP). At a minimum a cursory review is performed daily, preferably in the morning to provide a status of the data and instrument performance at monitoring sites. Detailed analysis can be extremely difficult for the data processing team when reviewing the raw data without the notations, notes and calibration information that the station operators provide for the group. The typical review process for the station operator and data reviewer(s) include:

- (SO) Review of zero, span, one point QC verification information, the hourly data, and any flags that could effect data and record any information on the daily summaries that might be vital to proper review of the data.
- (SO) Transfer strip charts both analog and digital information, daily summaries, monthly maintenance sheets, graphic displays of meta data and site log notes to the central location for a secondary and more thorough review.
- (SO) At the central location, review the data, marking any notations of invalidations and provide electronic strip charts, meta data charts, daily summaries, site notes, and monthly maintenance sheets for ready access by the data processing staff.
- (DP) Review zero, span and one point QC verifications, station notes, and monthly maintenance sheets for the month; check a percentage of all zero, span and one point verifications. Compare a defined number of hand reduced and/or strip chart readings to electronic data points generated by the DAS. If significant differences are observed, determine what corrective action steps are required.



## Outliers

Outliers are “measurements that are extremely large or small relative to the rest of the data and are suspected of misrepresenting the population from which they were collected” (EPAQA/G9R)<sup>6</sup>. When reviewing data, some potential outliers will be obvious such as, spikes in concentrations, data remaining the same for hours, or a sudden drop in concentration but still in the normal range of observed data. Many of these outlier checks can be automated and provide efficient real-time checks of data. Outliers do not necessarily indicate the data is invalid; they serve to alert the station operator and/or data reviewers there may be a problem. In fact, the rule of thumb for outliers should be that the data be considered valid until there is an explanation for why the data should be invalidated. At some point it may be necessary to exclude outliers from instantaneous reporting to the AIRNow network and/or AQI reporting until further investigation has occurred. EPA Guidance Documents<sup>7</sup> *Guidance on Environmental Data Verification and Validation* (EPA QA/G8) and *Guidance for Data Quality Assessment – a Reviewers Guide* (EPA QA/G9R) provide insight on outlier and data reviews in general.

## 14.2 Data Transfer – Public Reporting

The area of public reporting for air monitoring data may provide the largest number of users of data. This area has been growing rapidly in the last few years as a result of the increased availability of air quality reporting, especially for ozone and PM<sub>2.5</sub>. For public reporting of the AQI, the AIRNow web site will remain the EPA’s primary medium for distribution of air monitoring data. The additional continuous monitoring parameters collected from NCore will also be reported to AIRNow. These parameters are expected to be made publicly available for sharing throughout technical user communities. However, they are not expected to be widely distributed through AIRNow as products for public consumption.

This section will discuss the transfer of data from the monitoring organization to two major data repositories: 1) AIRNow for near real-time reporting of monitoring data, and 2) AQS for long term storage of validated data.

### 14.2.1 Real-time Data Reporting for AIRNow and NCore

One of the most important emerging uses of ambient monitoring data has been public reporting of the Air Quality Index (AQI). This effort has expanded on EPA’s AIRNow web site from regionally-based near real-time ozone mapping products color coded to the AQI, to a national multi-pollutant mapping, forecasting, and data handling system of real-time data. Since ozone and PM<sub>2.5</sub> drive the highest reporting of the AQI in most areas, these two pollutants are the only two parameters currently publicly reported from AIRNow. While other pollutants such as CO, SO<sub>2</sub>, NO<sub>2</sub>, and PM<sub>10</sub> may not drive the AQI, they are still important for forecasters and other data users to understand for model evaluation and tracking of air pollution episodes. Therefore, the NAAMS seeks the following goals:

- Share all continuous O<sub>3</sub>, PM<sub>2.5</sub> and PM<sub>10</sub> data, where available, across the nation;
- For NCore sites, share all gaseous CO, SO<sub>2</sub>, NO and NO<sub>y</sub> data and base meteorological measurements across the nation.

<sup>6</sup> <http://www.epa.gov/quality1/qs-docs/g9r-final.pdf>

<sup>7</sup> [http://www.epa.gov/quality1/qa\\_docs.html](http://www.epa.gov/quality1/qa_docs.html)

This program allows for short term non-validated data to be collected by a centrally located computer that displays the data in near real time data formats such as tables and contour maps. In addition, EPA, in conjunction with the monitoring organizations, developed the National Ambient Air Monitoring Strategy (NAAMS) which includes the development of the NCore network. This section will discuss the needs of real time data acquisition for the deployment of AIRNow and the NAAMS.

## Reporting Intervals

Currently, hourly averages are the reporting interval for continuous particulate and gaseous data. These are the reporting intervals for both AQS (AQS supports a variety of reporting intervals) and to AIRNow for AQI purposes. These reporting intervals will meet most of the multiple objectives of NCore for supporting health effects studies, AQI reporting, trends, NAAQS attainment decisions, and accountability of control strategies. However, with these objectives also comes the desire for data at finer time resolutions: 5 minute averages for gaseous pollutants and sub-hourly averages for certain particulate matter monitors. Examples of this need for finer time resolution of data include, but are not limited to: tracking air pollution episodes, providing data for exposure studies, model evaluation, and evaluating shorter averaging periods for potential changes to the NAAQS. Monitoring organizations generally have the hardware and software necessary to log and report this data. The challenge to obtaining and reporting the data is the current communication packages used, such as conventional telephone modem polling. One widely available solution to this would be the use of internet connectivity, allowing data at individual monitoring sites to be pushed to a central server rather than being polled. Monitoring organizations should begin to investigate the possibilities of using this media.

With this generation of data having a shorter averaging interval, the challenge becomes validation of all the data. The historical perception has been that each criteria pollutant measurement needs to be verified and validated manually. With the amount of data generated, this would be a time-consuming task. To provide a nationally consistent approach for the reporting interval of data, the NCore networks will take a tiered approach to data reporting. At the top tier, hourly data intervals will remain the standard for data reporting. Long term, the NCore networks will be capable of providing at least 5 minute intervals for those methods that have acceptable data quality at those averaging periods. For QA/QC purposes such as zero/span and one-point QC, monitoring organizations should be capable of assessing data on at least a 1-minute interval.

With instantaneous data going to external websites, monitoring organizations operating their own websites containing the same local and/or regional data should add a statement about the quality of data being displayed at the site. This cautionary statement will notify the public that posted data has not been fully quality assured and discrepancies may occur. For an example, the AIRNow Website makes the statement

*“Although some preliminary data quality assessments are performed, the data as such are not fully verified and validated through the quality assurance procedures monitoring organizations use to officially submit and certify data on the EPA AQS(Air Quality System). Therefore, data are used on the AIRNow Web site only for the purpose of reporting the AQI. Information on the AIRNow web site is not used to formulate or support regulation, guidance or any other Agency decision or position.”*

## 14.2.2 Reporting Frequency and Lag Time for Reporting Data

Continuous monitoring data that are being shared in near real-time from NCore monitoring stations are to be reported each hour. Data should be reported as soon as practical after the end of each hour. For the near term, the goal is to report data within twenty minutes past the end of each hour. This will provide enough time for data processing and additional validation at the Data Management Center (DMC); generation of reports and maps; distribution of those products to a variety of stakeholders and web sites; and still allow enough time for staff review before the end of the hour. This is an important goal to support reporting of air pollution episodes on news media programs by the top of the hour. The long term goal is to report all data within five minutes after the end of an hour. This will further enhance NCore's ability to deliver timely data within a reasonable time period that takes advantage of existing commercially available technology.

## 14.3 Data Transfer-Reporting to External Data Bases

Today, the need for the ambient air monitoring data reaches outside the monitoring community. In addition to the traditional needs of the data, determination of NAAQS compliance and the daily AQI report, a health researcher or modeler may want a very detailed accounting of the available data in the shortest time intervals possible. Atmospheric scientists typically desire data in a relatively unprocessed yet comprehensive form with adequate descriptions (meta data) to allow for further processing for comparability to other data sets. These needs increase the demands for the data and require multiple reports of the information.

### 14.3.1 AQS Reporting

All ambient air monitoring data will eventually be transferred and stored in AQS. The current system, implemented in early 2002, has much more functionality than the previous main-frame system. As stated in 40 CFR Part 58.16<sup>8</sup>, the monitoring organization shall report all ambient air monitoring and associated quality assurance data and information specified by the AQS Users Guide into the AQS format. The data is to be submitted electronically and on a specified quarterly basis. Since changes in reporting requirement occur, monitoring organization should review CFR for the specifics of this requirement.

The AQS manuals are located at the AQS Website<sup>9</sup>. This site contains the old AIRS/AQS manuals as well as the new AQS Manuals. The AQS Data Coding Manual replaces the previous Volume II and provides coding instructions, edits performed, and system error messages. The AQS User Guide replaces the former Volume III and describes the procedures for data entry. Both manuals will be updated as needed and the new versions will be available at the web site. Table 14-1 provides the units and the number of decimal places that, at a minimum, are required for reporting to AQS for the criteria pollutants. These decimal places are used for comparison to the NAAQS and are displayed in AQS summary reports. However, monitoring organizations can report data up to 5 values to the right of the decimal (beyond five AQS will truncate). Within the five values to the right of the decimal place, AQS will round to the minimum displayed in Table 14-1. Reported values will remain in raw data files.

---

<sup>8</sup> <http://www.access.gpo.gov/nara/cfr/cfr-table-search.html>

<sup>9</sup> <http://www.epa.gov/ttn/airs/airsaqs/manuals/>

**Table 14-1 AQS Data Reporting Requirements**

Pollutant	Decimal Places	Example	Units
PM <sub>2.5</sub>	1	10.2	μg/m <sup>3</sup>
PM <sub>10</sub>	1	26.2	μg/m <sup>3</sup>
PM <sub>10-2.5</sub>	1	10.2	μg/m <sup>3</sup>
Lead	1	1.5	μg/m <sup>3</sup>
SO <sub>2</sub>	2	0.03	ppm
NO <sub>2</sub>	3	0.053	ppm
CO	1	2.0	ppm
O <sub>3</sub>	3	0.108	ppm
PAMS (VOCs)	2	6.23	ppb-carbon

### 14.3.2 Standard Format for Reporting to AQS

AQS allows flexibility in reporting formats. The formats previously used by AQS can be used for raw data (hourly, daily, or composite) and for reporting precision and bias data. The system also has new report formats for this data as well as formats for registering new sites and monitors. These new formats are defined in the AQS Data Coding Manual. Work is also in progress to define an Extensible Markup Language (XML) schema for AQS to allow for that reporting format as well. Use of XML as a data format is consistent with EPA and Federal guidelines towards better data integration and sharing.

### 14.3.3 Annual Certification of Data

The annual data certification is also stored in AQS. The monitoring organization is required to certify the data (by formal letter) for a calendar year (Jan 1-Dec 31) by July 1 through the year 2009. Beginning in 2010 the annual data certification letter is due by May 1. See 40 CFR Part 58.15 for details. This certification requires the monitoring organization to review the air quality data and precision/bias data for completeness and validity and to submit a certification letter to the Regional Office. The certification letter and accompanying reports are reviewed and if the results of the review are consistent with the criteria for certification, the certification flag is set in the AQS database. After certification is complete, any updates to the data will cause the critical review process to identify that the certified data has been changed and the certification flag will be dropped.

### 14.3.4 Summary of Desired Performance for Information Transfer Systems

To define the needed performance criteria of a state-of-the art information technology system, a table of needs has been developed. This table provides performance needs for an optimal information technology system, but is not intended to address what the individual components should look like. For instance, once low level validated data for a specific time period are ready to leave the monitoring station, a number of telemetry systems may actually accomplish moving those data. By identifying the needed performance criteria of moving data, rather than the actual system to move it, monitoring organizations may be free to identify the most optimal system for their network. Table 14-2 summarizes the performance elements of the data management systems used to log, transfer, validate, and report data from NCore ambient air monitoring stations.

**Table 14-2 NCore (Level 2 and 3) Information Technology Performance Needs**

Performance Element	Performance Criteria	Notes
<b>Sample Periods</b>	5 minutes (long term goal), and 1 hour data (current standard)	5 minutes and 1 hour data to support exposure, mapping and modeling. 1 hour data for Air Quality Index reporting and NAAQS. Sample period may need to be higher for certain pollutant measurement systems depending on method sample period and measurement precision when averaging small time periods.
<b>Data Delivery</b>	Near Term goal - Within 20 minutes nationally each hour Long term goal - Within 5 minutes nationally each hour	As monitoring organizations migrate to new telemetry systems the goal will be to report data within 5 minutes. This should be easily obtained with broadband pushing of data to a central server.
<b>Low Level Validation</b>	- Last automated zero and QC check acceptable - Range check acceptable - Shelter parameters acceptable -Instrument parameters acceptable	Other validation should be applied as available: - site to site checks - rate of change -lack of change.
<b>Data Availability</b>	- all QC data, operator notes, calibrations, and pollutant data within network - Low level validated pollutant data externally	Create log of all monitoring related activities internally. Allow only validated data to leave monitoring organization network.
<b>Types of monitoring data to disseminate-externally</b>	-continuous and semi-continuous pollutant data -accompanying meteorological data	Associated manual method supporting data (for instance FRM ambient Temperature) should be collected but not reported externally.
<b>Additional data for internal tracking</b>	Status of ancillary equipment such as shelter temperature, power surges, zero air system, calibration system	
<b>Relevant site information</b>	Latitude, longitude, altitude, land use category, scale of representativeness, pictures and map of area	Other site information may be necessary.
<b>Remote calibration</b>	Ability to initiate automated calibrations on regular schedule or as needed	
<b>Reviewing calibration</b>	- allow for 1 minute data as part of electronic calibration log	
<b>Initialization of manual collection method</b>	Need to be able to remotely initiate these or have them set at an action level from a specific monitor	
<b>Reporting Format</b>	Short Term - Maintain "Obs" file format and pipe delimited formats for AIRNow and AQS reporting, respectively Near Term -XML	Need to coordinate development of XML schema with multiple stakeholders. XML is an open format that will be able to be read by most applications.

## 14.4 Data Management

Managing the data collected is just as important as correctly collecting the data. The amount of data collected will continue to grow based on the needs of the data users. Previous sections have confirmed this statement providing a glimpse of the potential data users and the uses. Generally, data is to be retained for a period of 3 years from the date the grantee submits its final expenditure report unless otherwise noted in the funding agreement. Refer to 40 CFR Part 31.42. With electronic records and electronic media, this information can be stored and managed with less use of space than with the conventional paper records. However, even with today's technology there will be some paper records and those need to be managed in an orderly manner. The manner in which a monitoring organization manages its data is documented in its QMP and QAPP.

All information collected in any ambient air monitoring program should be organized in a logical and systematic manner. There is no one best way to organize a system. How a monitoring organization

organizes its information is required to be discussed in its QMP (QA/R-2)<sup>10</sup> and QAPP (QA/R-5)<sup>11</sup>. Monitoring organizations should consult EPA's records management webpage<sup>12</sup> for other useful information when beginning to plan or revise how its data records are stored.

This information should be reviewed not only by those in a monitoring organization responsible for overall data management but also by the monitoring organization's Systems or Network Administrator. The latter person(s) can provide helpful information in designing the overall data management system according to today's industry standards. Remember, the data has to be of known quality, reliable and defensible. In order for monitoring organizations to continue to meet those objectives, many sources of information need to be reviewed.

Section 5 presented guidance on documentation and records. This information can be helpful in managing ambient air monitoring data. In addition, the EPA Office of Environmental Information (OEI) has a website<sup>13</sup> that provides information management policies and guidance. As an example the document *Good Automated Laboratory Practices*, described earlier in this document, is posted on the OEI website and can be very useful in developing information management systems.

---

<sup>10</sup> <http://www.epa.gov/quality1/qs-docs/r2-final.pdf>

<sup>11</sup> <http://www.epa.gov/quality1/qs-docs/r5-final.pdf>

<sup>12</sup> <http://www.epa.gov/records/>

<sup>13</sup> <http://www.epa.gov/irmpoli8/policies.htm>

## 15.0 Assessment and Corrective Action

An assessment is an evaluation process used to measure the performance or effectiveness of a system and its elements. It is an all-inclusive term used to denote any of the following: audit, performance evaluation, management systems review, peer review, inspection and surveillance. For the Ambient Air Quality Monitoring Program, the following assessments will be discussed: network reviews, performance evaluations, technical systems audits and data quality assessments.

### 15.1 Network Reviews

Beginning July 2007, the State, or where applicable, local monitoring organizations shall adopt and submit to the Regional Administrator an annual monitoring network plan which shall provide for the establishment and maintenance of an air quality surveillance system that consists of a network of SLAMS monitoring stations including FRM, FEM, and ARM monitors that are part of SLAMS, NCore stations, STN stations, State speciation stations, SPM stations, and/or, in serious, severe and extreme ozone nonattainment areas, PAMS stations, and SPM stations. The plan shall include a statement of purposes for each monitor and evidence that siting and operation of each monitor meets the requirements of appendices A, C, D, and E of Part 58, where applicable. The annual monitoring network plan must be made available for public inspection for at least 30 days prior to submission to EPA. The AMTIC Website has a page<sup>1</sup> devoted to the progress and adherence to this requirement. This page contains links to State and local ambient air monitoring plans.

In addition to an annual network plan, starting in 2010, the State, or where applicable local, monitoring organization shall perform and submit to the EPA Regional Administrator an assessment of the air quality surveillance system every 5 years to determine, at a minimum, if the network meets the monitoring objectives defined in 40 CFR Part 58, Appendix D, whether new sites are needed, whether existing sites are no longer needed and can be terminated, and whether new technologies are appropriate for incorporation into the ambient air monitoring network. The network assessment must consider the ability of existing and proposed sites to support air quality characterization for areas with relatively high populations of susceptible individuals (e.g., children with asthma), and, for any sites that are being proposed for discontinuance, the effect on data users other than the monitoring organization itself, such as nearby States and Tribes or health effects studies. For PM<sub>2.5</sub>, the assessment also must identify needed changes to population-oriented sites. The State, or where applicable, local monitoring organization must submit a copy of this 5-year assessment, along with a revised annual network plan, to the Regional Administrator.

Conformance with network requirements of the Ambient Air Monitoring Network set forth in 40 CFR Part 58, Appendices D and E are determined through annual network reviews of the ambient air quality monitoring system. The annual review of the network is used to determine how well the network is achieving its required monitoring objectives and how it should be modified to continue to meet its objectives. Most network reviews are accomplished by the EPA Regional Office, however, the following information can be useful to State and local organizations to prepare for reviews or assess their networks.

In order to maintain consistency in implementing and collecting information from a network review, EPA has developed SLAMS/PAMS Network Review Guidance. The information presented in this section provides some excerpts from this guidance document.

---

<sup>1</sup> <http://www.epa.gov/ttn/amtic/plans.html>

### 15.1.1 Network Selection

Due to the resource-intensive nature of network reviews, it may be necessary to prioritize monitoring organizations and/or pollutants to be reviewed. The following criteria may be used to select networks:

- date of last review;
- areas where attainment/nonattainment designations are taking place or are likely to take place;
- results of special studies, saturation sampling, point source oriented ambient monitoring, etc.; and
- monitoring organizations which have proposed network modifications since the last network review.

In addition, pollutant-specific priorities may be considered (e.g., newly designated ozone nonattainment areas, PM<sub>10</sub> "problem areas", etc.). Once the monitoring organizations have been selected for review, significant data and information pertaining to the review should be compiled and evaluated. Such information might include the following:

- network files for the selected monitoring organization (including updated site information and site photographs);
- AQS reports (AMP220, 225, 255, 380, 390, 450);
- air quality summaries for the past five years for the monitors in the network;
- emissions trends reports for major metropolitan areas;
- emission information, such as emission density maps for the region in which the monitor is located and emission maps showing the major sources of emissions; and
- National Weather Service summaries for monitoring network area.

Upon receiving the information, it should be checked to ensure it was the latest revision and for consistency. Discrepancies should be noted on the checklist (Appendix H) and resolved with the monitoring organization during the review. Files and/or photographs that need to be updated should also be identified.

### 15.1.2 Conformance to 40 CFR Part 58 Appendix D- Network Design Requirements

With regard to 40 CFR Part 58 Appendix D requirements, the network reviewer must determine the adequacy of the network in terms of number and location of monitors: specifically, (1) is the monitoring organization meeting the number of monitors required by the design criteria requirements; and (2) are the monitors properly located, based on the monitoring objectives and spatial scales of representativeness?

#### Number of Monitors

For SLAMS, the minimum number of monitors required is specified in the regulations for ozone, PM<sub>10</sub>, PM<sub>2.5</sub>, and PAMS. The other criteria pollutants do not have minimum requirements and is determined by the Regional Office and the monitoring organizations on a case-by-case basis to meet the monitoring objectives specified in Appendix D. Adequacy of the network may be determined by using a variety of tools, including the following:

- maps of historical monitoring data;
- maps of emission densities;
- dispersion modeling;
- special studies/saturation sampling;
- best professional judgment;
- SIP requirements; and
- revised monitoring strategies (e.g., lead strategy, reengineering air monitoring network).



## Location of Monitors

For the ozone, PM<sub>10</sub>, and PM<sub>2.5</sub> SLAMS sites, Appendix D does provide general locations of sites in regards to NAAQS related concentrations. For other criteria pollutants the location of monitors is not specified in the regulations, but is determined by the Regional Office and State monitoring organizations on a case-by-case basis to meet the monitoring objectives specified in Appendix D. Adequacy of the location of monitors can only be determined on the basis of stated objectives. Maps, graphical overlays, and GIS-based information can be extremely helpful in visualizing or assessing the adequacy of monitor locations. Plots of potential emissions and/or historical monitoring data versus monitor locations are especially useful.

For PAMS, there is considerable flexibility when locating each PAMS within a nonattainment area or transport region. The three fundamental criteria which need to be considered when locating a final PAMS site are: (1) sector analysis - the site needs to be located in the appropriate downwind (or upwind) sector (approximately 45°) using appropriate wind directions; (2) distance - the sites should be located at distances appropriate to obtain a representative sample of the areas precursor emissions and represent the appropriate monitoring scale; and (3) proximate sources.

### 15.1.3 Conformance to 40 CFR Part 58, Appendix E - Probe Siting Requirements

Applicable siting criteria for SLAMS, and PAMS are specified in 40 CFR Part 58, Appendix E. The on-site visit itself consists of the physical measurements and observations needed to determine compliance with the Appendix E requirements, such as height above ground level, distance from trees, paved or vegetative ground cover, etc. Prior to the site visit, the reviewer should obtain and review the following:

- most recent hard copy of site description (including any photographs)
- data on the seasons with the greatest potential for high concentrations for specified pollutants
- predominant wind direction by season

The checklist provided in Appendix H of this Handbook is also intended to assist the reviewer in determining conformance with Appendix E. In addition to the items on the checklist, the reviewer should also do the following:

- ensure that the manifold and inlet probes are clean
- estimate probe and manifold inside diameters and lengths
- inspect the shelter for weather leaks, safety, and security
- check equipment for missing parts, frayed cords, etc.
- check that monitor exhausts are not likely to be introduced back to the inlet
- record findings in field notebook and/or checklist
- take photographs/videotape in the 8 directions
- document site conditions, with additional photographs/videotape

### 15.1.4 Checklists and Other Discussion Topics

Checklists are provided in Appendix H to assist network reviewers (SLAMS and PAMS) in conducting the review. In addition to the items included in the checklists, other subjects for possible discussion as part of the network review and overall adequacy of the monitoring program include:

- installation of new monitors;
- relocation of existing monitors;
- siting criteria problems and suggested solutions;
- problems with data submittals and data completeness;
- maintenance and replacement of existing monitors and related equipment;
- quality assurance problems;
- air quality studies and special monitoring programs; and
- other issues (proposed regulations/funding).

### 15.1.5 Summary of Findings

Upon completion of the network review, a written network evaluation should be prepared. The evaluation should include any deficiencies identified in the review, corrective actions needed to address the deficiencies, and a schedule for implementing the corrective actions. The kinds of discrepancies/deficiencies to be identified in the evaluation include discrepancies between the monitoring organization network description and the AQS network description; and deficiencies in the number, location, and/or type of monitors.



NPAP through the probe audit



PEP Audit

## 15.2 Performance Evaluations

Performance evaluations (PEs) are a type of audit in which the quantitative data generated in a measurement system are obtained independently and compared with routinely obtained data to evaluate the proficiency of an analyst, or a laboratory<sup>2</sup>. The National Performance Evaluation Programs:

- Allow one to determine data comparability and usability across sites, monitoring networks (Tribes, States, and geographic regions), instruments and laboratories.
- Provide a level of confidence that monitoring systems are operating within an acceptable level of data quality so data users can make decisions with acceptable levels of certainty.
- Help verify the precision and bias estimates performed by monitoring organizations.
- Identify where improvements (technology/training) are needed.
- Assure the public of non-biased assessments of data quality.

<sup>2</sup> American National Standard-Quality Systems for Environmental Data and Technology Programs-Requirements with Guidance for Use (ANSI/ASQC E4-2004)

- Provide a quantitative mechanism to defend the quality of data.
- Provide information to monitoring organizations on how they compare with the rest of the nation, in relation to the acceptance limits and to assist in corrective actions and/or data improvements.

Some type of national PE program is implemented for all of the ambient air monitoring activities. Table 15-1 provides more information on these activities. It is important that these performance evaluations be independent in order to ensure they are non-biased and objective. With the passage of the Data Quality Act<sup>3</sup>, there is potential for EPA to receive challenges to the quality of the ambient air data. Independent audits help provide another piece of objective evidence on the quality of a monitoring organizations data and can help EPA defend the quality of the data.

**Table 15-1 National Performance Evaluation Activities Performed by EPA**

<b>Program/ Lead Agency</b>	<b>Explanation</b>
NPAP OAQPS	National Performance Audit Program provides audit standards for the gaseous pollutants either as devices that the site operator connects to the back of the instrument or through the probe in which case the audits are conducted by presenting audit gases through the probe inlet of ambient air monitoring stations. Flow audit devices and lead strips are also provided through NPAP. NPAP audits are required at 20% of a primary quality assurance organizations sites each year with a goal of auditing all sites in 5-7 years.
PM <sub>2.5</sub> PM <sub>10-2.5</sub> PEP OAQPS	Performance Evaluation Program. The strategy is to collocate a portable FRM PM <sub>2.5</sub> or PM <sub>10-2.5</sub> air sampling audit instrument with an established primary sampler at a routine air monitoring site, operate both samplers in the same manner, and then compare the results. Each year five PEP audits are required for primary quality assurance organizations (PQAOs) with less than or equal to 5 monitoring sites or eight audits are required for PQAOs with greater than five sites. These audits are not required for PM <sub>10</sub> .
NATTS PT OAQPS	A National Air Toxics Trend Sites (NATTS) proficiency test (PT) is a type of assessment in which a sample, the composition of which is unknown to the analyst, is provided to test whether the analyst/laboratory can produce analytical results within the specified acceptance criteria. PTs for volatile organic carbons (VOCs), carbonyls and metals are performed quarterly for the ~22 NATTS laboratories
SRP ORIA-LV	The Standard Reference Photometer (SRP) Program provides a mechanism to establish traceability among the ozone standards used by monitoring organizations with the National Institute of Standards and Technology (NIST). Every year NIST certifies an EPA SRP. Upon certification, this SRP is shipped to the EPA Regions who use this SRP to certify the SRP that remains stationary in the Regional Lab. These stationary SRPs are then used to certify the ozone transfer standards that are used by the State, Local and Tribal monitoring organizations who bring their transfer standards to the Regional SRP for certification.
PAMS Cylinder Certs ORIA LV	EPA developed a system to certify the standards used by the monitoring organizations to calibrate their PAMS analytical systems. The standards are sent to the EPA Office of Radiation and Indoor Air (ORIA-LV) who perform an independent analysis/certification of the cylinders. This analysis is compared to the vendor concentrations to determine if they are within the contractually required acceptance tolerance.
STN/IMPROVE Round Robins PTs and Audits ORIA-AL	PM <sub>2.5</sub> Speciation Trends Network (STN) and IMPROVE Round Robins are a type of performance evaluation where the audit samples are developed in ambient air; therefore, the true concentration is unknown. The Office of Indoor Air and Radiation (ORIA) in Montgomery, AL implement these audits for the STN/IMPROVE programs and for the PEP weighing laboratories. The audit is performed by collecting samples over multiple days and from multiple samplers. These representative samples are then characterized by the ORIA lab and sent to the routine sample laboratories for analysis. Since the true concentrations are unknown, the reported concentrations are reviewed to determine general agreement among the laboratories. In addition ORIA implements technical systems audits of IMPROVE and STN laboratories
Protocol Gas OAQPS	EPA Protocol Gases are used in quality control activities (i.e., calibrations, audits etc.) to ensure the quality of data derived from ambient air monitors used by every State in the country. EPA developed the Protocol Gas Program to allow standards sold by specialty gas producers to be considered traceable to NIST standards. This program was discontinued in 1998. In 2002, there was interest by the gas vendors and EPA to reestablish this program. The program is presently (as of 2008) undergoing re-structuring.

Although Table 15-1 lists seven performance evaluation programs operating at the federal level, the NPAP and PEP Programs will be discussed in more detail. Additional information on both programs can be found on the AMTIC Website<sup>4</sup>. The October 17, 2006 monitoring rule identified the monitoring organizations as responsible for ensuring the implementation of these audits<sup>5</sup>. Monitoring organizations

<sup>3</sup> see [www.eenews.net/Greenwire/Backissues/081604/08160403.htm](http://www.eenews.net/Greenwire/Backissues/081604/08160403.htm)

<sup>4</sup> <http://www.epa.gov/ttn/amtic/npepqa.html>

<sup>5</sup> <http://www.epa.gov/ttn/amtic/40cfr53.html>-Final - Revisions to Ambient Air Monitoring Regulations.

can either implement the program itself or continue to participate in the federally implemented program. This choice is provided to the monitoring organization on an annual basis through a memo from OAQPS through the EPA Regions. In order for monitoring organization to self-implement the program they must meet criteria related to the adequacy of the audit (number of audits and how it is accomplished) as well as meet independence requirements (see Figure 15.1).

### 15.2.1 National Performance Audit Program<sup>6</sup>

Monitoring organizations operating SLAMS/PAMS/PSD are required to participate in the National Performance Evaluation Programs by providing adequate and independent audits for its monitors as per Section 2.4 of 40 CFR Part 58, Appendix. One way of providing the audits is to participate in the NPAP program either through self-implementation or federal implementation.

The NPAP is a cooperative effort among OAQPS, the 10 EPA Regional Offices, and the monitoring organizations that operate the SLAMS/PAMS/PSD air pollution monitors. The NPAP's goal is to provide audit materials and devices that will enable EPA to assess the proficiency of monitoring organizations that are operating monitors in the SLAMS/PAMS/PSD networks. To accomplish this, the NPAP has established acceptable limits or performance criteria, based on the data quality needs of the networks, for each of the audit materials and devices used in the NPAP.

All audit devices and materials used in the NPAP are certified as to their true value, and that certification is traceable to a National Institute of Standards and Technology (NIST) standard material or device wherever possible. The audit materials used in the NPAP are as representative and comparable as possible to the calibration materials and actual air samples used and/or collected in the SLAMS/PAMS/PSD networks. The audit material/gas cylinder ranges used in the NPAP are specified in the Federal Register.

Initially the NPAP system was a mailable system where standards and gasses were mailed to monitoring organizations for implementation. In 2003, OAQPS started instituting a through the probe audit system where mobile laboratories are sent to monitoring sites and audit gasses are delivered through the inlet probe of the analyzers. The goal of the NPAP audit is:

- Performing audits at 20 percent of monitoring sites per year, and 100% in 5-7 years.
- Data submission to AQS.
- Development of a delivery system that will allow for the audit concentration gasses to be introduced to the probe inlet where logistically feasible.
- Use of audit gases that are NIST certified and validated at least once a year for CO, SO<sub>2</sub>, and NO<sub>2</sub>.
- Validation/certification with the EPA NPAP program through collocated auditing, at an acceptable number of sites each year. The comparison tests would have to be no greater than **5 percent** different from the EPA NPAP results.
- Incorporation of NPAP in the monitoring organization's quality assurance project plan (if self implementing).

Table 15-2 lists the acceptance limits of the NPAP audits.

---

<sup>6</sup> <http://www.epa.gov/ttn/amtic/npapgen.html>

**Table 15-2 NPAP Acceptance Criteria**

Audit	EPA determined limits
High volume/PM <sub>10</sub> (SSI)	% difference ≤15% for 1 or more flows
Dichot (PM <sub>10</sub> )	% difference ≤15% for 1 or more flows
Pb (analytical)	% difference ≤15% for 1 or more levels
SO <sub>2</sub> , NO <sub>2</sub> , and CO	Mean absolute % difference ≤ 15%
O <sub>3</sub>	Mean absolute % difference ≤ 10%
PAMS	
Volatile Organic Compounds	Compound Specific
Carbonyls	Compound and level specific

### 15.2.2 PM<sub>2.5</sub> and PM<sub>10-2.5</sub> Performance Evaluation Program (PEP)

The Performance Evaluation Program<sup>7</sup> is a quality assurance activity which will be used to evaluate measurement system bias of the PM<sub>2.5</sub> and the PM<sub>10-2.5</sub> monitoring networks. The pertinent regulations for this performance audit are found in 40 CFR Part 58, Appendix A. The strategy is to collocate a portable PEP instrument with an established routine air monitoring site, operate both monitors in exactly the same manner and then compare the results of this instrument against the routine sampler at the site. For primary quality assurance organizations with less than or equal to five monitoring sites, five valid performance evaluation audits must be collected and reported each year. For primary quality assurance organizations with greater than five monitoring sites, eight valid performance evaluation audits must be collected and reported each year. A valid performance evaluation audit means that both the primary

**Independent assessment** - an assessment performed by a qualified individual, group, or organization that is not part of the organization directly performing and accountable for the work being assessed. This auditing organization must not be involved with the generation of the routine ambient air monitoring data. An organization can conduct the PEP if it can meet the above definition and has a management structure that, at a minimum, will allow for the separation of its routine sampling personnel from its auditing personnel by two levels of management, as illustrated in the figure below. In addition, the pre and post weighing of audit filters must be performed by separate laboratory facility using separate laboratory equipment. Field and laboratory personnel would be required to meet the FRM Performance Audit field and laboratory training and certification requirements. The State and local organizations are also asked to consider participating in the centralized field and laboratory standards certification process.

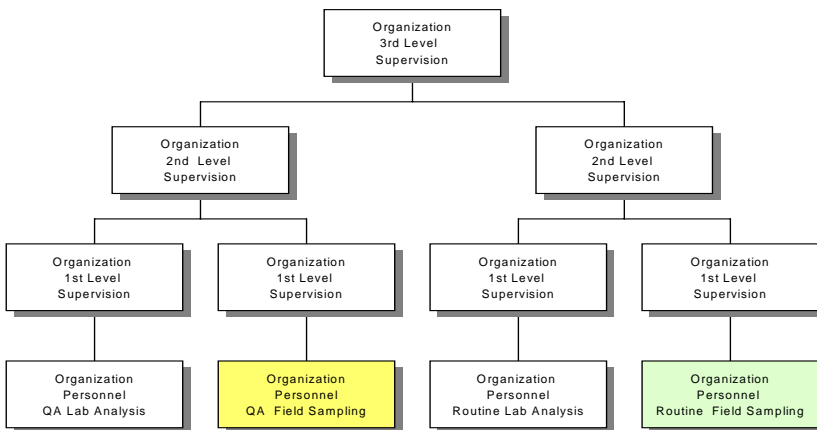

**Figure 15.1 Definition of independent assessment**

monitor and PEP audit concentrations are valid and above 3 µg/m<sup>3</sup>. Additionally, each year, every designated FRM or FEM within a primary quality assurance organization must: (1) have each method designation evaluated each year; and, (2) have all FRM or FEM samplers subject to a PEP audit at least once every six years; which equates to approximately 15 percent of the monitoring sites audited each year.

Since performance evaluations are independent assessments, Figure 15.1 was developed to define independence for the FRM performance evaluation to allow monitoring organizations to implement this activity.

<sup>7</sup> <http://www.epa.gov/ttn/amtic/pmpep.html>

Since the regulations define the performance evaluations as an NPAP like activity, EPA has made arrangements to implement this audit. Monitoring organizations can determine, on a yearly basis, to utilize federal implementation by directing their appropriate percentage of grant resources back to the OAQPS or implement the audit themselves. The following activities will be established for federal PEP implementation:

- field personnel assigned to each EPA Region, the hours based upon the number of required audits in the Region; and
- one national laboratory in Region 4 will serve as a national weighing lab and will include data submittal to AQS.

All documentation including the PEP Implementation Plan, QAPP, Field and Laboratory SOPs, and reports can be found on the AMTIC Bulletin Board at the PEP Website<sup>8</sup>.

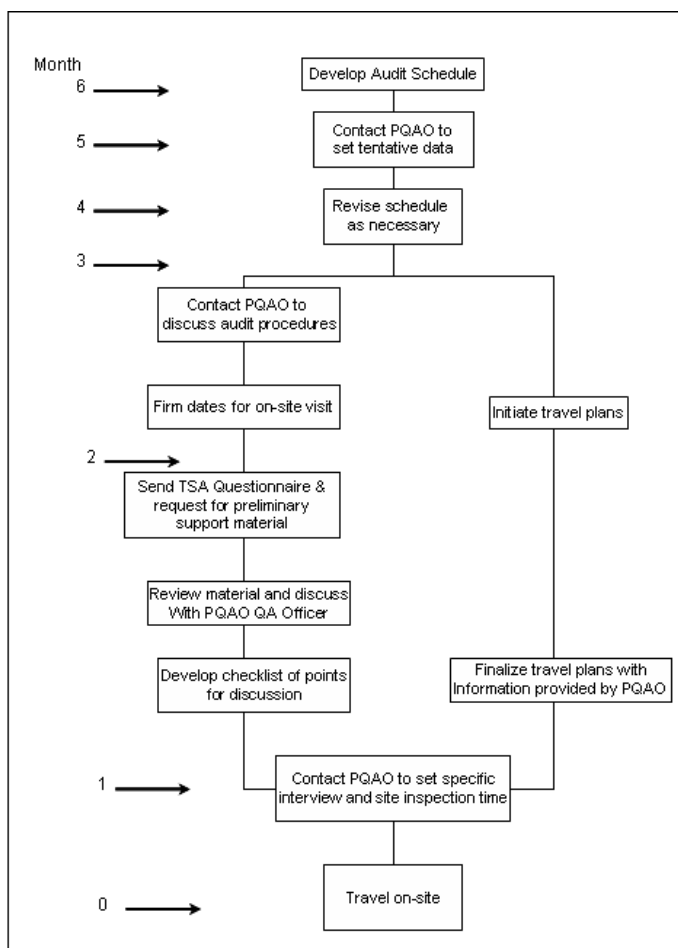

Figure 15.2 Pre-audit activities

### 15.2.3 State and Local Organization Performance Audits

Any of the performance evaluation activities mentioned in this section can be performed internally by the monitoring organizations. If the monitoring organization intends to self-implement NPAP or PEP then they will be required to meet the adequacy and independence criteria mentioned in earlier sections. Since a monitoring organization may want more audits than can be supplied by the NPAP and PEP, it may decide to “augment” the federally implemented programs with additional performance audits. These audits can be tailored to the needs of the monitoring organization and do not necessarily need to follow NPAP and PEP adequacy and independence requirements. Some information on the procedures for this audit can be found in Appendix H.

### 15.3 Technical Systems Audits

A systems audit is an on-site review and inspection of a monitoring organization’s ambient air monitoring program to assess its compliance with established regulations governing the collection, analysis, validation,

and reporting of ambient air quality data. A systems audit of each monitoring organization within an EPA Region is performed every three years by a member of the Regional Quality Assurance (QA) staff.

<sup>8</sup> <http://www.epa.gov/ttn/amtic/pmpep.html>

Detailed discussions of the audits performed by the EPA and the State and local organizations are found in Appendix H; the information presented in this section provides general guidance for conducting technical systems audits. A systems audit should consist of three separate phases:

- Pre-audit activities.
- On-site audit activities.
- Post-audit activities.

Summary activity flow diagrams have been included as Figures 15.2, 15.3 and 15.5, respectively. The reader may find it useful to refer to these diagrams while reading this guidance.

### 15.3.1 Pre-Audit Activities

At the beginning of each fiscal year, the audit lead or a designated member of the audit team should establish a tentative schedule for on-site systems audits of the monitoring organizations within their Region. It is suggested that the audit lead develop an audit plan. This plan should address the elements listed in Table 15-3. The audit plan is not a major undertaking and in most cases will be a one page table or report. However, the document represents thoughtful and conscious planning for an efficient and successful audit. The audit plan should be made available to the organization audited, with adequate lead time to ensure that appropriate personnel and documents are available for the audit. Three months prior to the audit, the audit lead should contact the quality assurance officer (QAO) of the organization to be audited to coordinate specific dates and schedules for the on-site audit visit. During this initial contact, the audit lead should arrange a tentative schedule for meetings with key personnel as well as for inspection of selected ambient air quality monitoring and measurement operations. At the same time, a schedule should be set for the exit interview used to debrief the monitoring organization director or his/her designee, on the systems audit outcome. As part of this scheduling, the audit lead should indicate any special requirements such as access to specific areas or activities. The audit lead should inform the monitoring organization QAO that the QAO will receive a questionnaire, which is to be reviewed and completed.

**Table 15-3 Suggested Elements of an Audit Plan**

Audit Title -	Official title of audit that will be used on checksheets and reports
Audit #-	Year and number of audit can be combined; 08-1, 08-2 Date of audit
Scope -	Establishes the boundary of the audit and identifies the groups and activities to be evaluated. The scope can vary from general overview, total system, to part of system, which will determine the length of the audit.
Purpose -	What the audit should achieve
Standards -	Standards are criteria against which performance is evaluated. These standards must be clear and concise and should be used consistently when auditing similar facilities or procedures. The use of audit checklists is suggested to assure that the full scope of an audit is covered. An example checklist for the Regional TSA is found in Appendix H.
Audit team -	Team lead and members.
Auditees -	People who should be available for the audit from the audited organization. This should include the program manager(s), principal investigator(s), monitoring leads, organizations QA representative(s), and other management and technicians as necessary.
Documents -	Documents that should be available in order for the audit to proceed efficiently. Too often documents are asked for during an audit, when auditors do not have the time to wait for these documents to be found. Documents could include QMPs, QAPPs, SOPs, GLPs, control charts, raw data, QA/QC data, previous audit reports etc.
Timeline -	A timeline of when organizations (auditors/auditees) will be notified of the audit in order for efficient scheduling and full participation of all parties.



The audit lead should emphasize that the completed questionnaire is to be returned within one (1) month (or time frame deemed appropriate) of receipt. The information within the questionnaire is considered a minimum, and both the Region and the monitoring organization under audit should feel free to include additional information. Once the completed questionnaire has been received, it should be reviewed and compared with the pertinent criteria and regulations. The AQS precision, bias and completeness data as well as any other information on data quality can augment the documentation received from the reporting organization under audit. This preliminary evaluation will be instrumental in selecting the sites to be evaluated and in the decision on the extent of the monitoring site data audit. The audit team should then prepare a checklist detailing specific points for discussion with monitoring organization personnel.

The audit team should be made of several members to offer a wide variety of backgrounds and expertise. This team may then divide into groups once on-site, so that both audit coverage and time utilization can be optimized. A possible division may be that one group assesses the support laboratory and headquarters operations while another evaluates sites, and subsequently assesses audit and calibration information. The audit lead should confirm the proposed audit schedule with the audited organization immediately prior to traveling to the site.

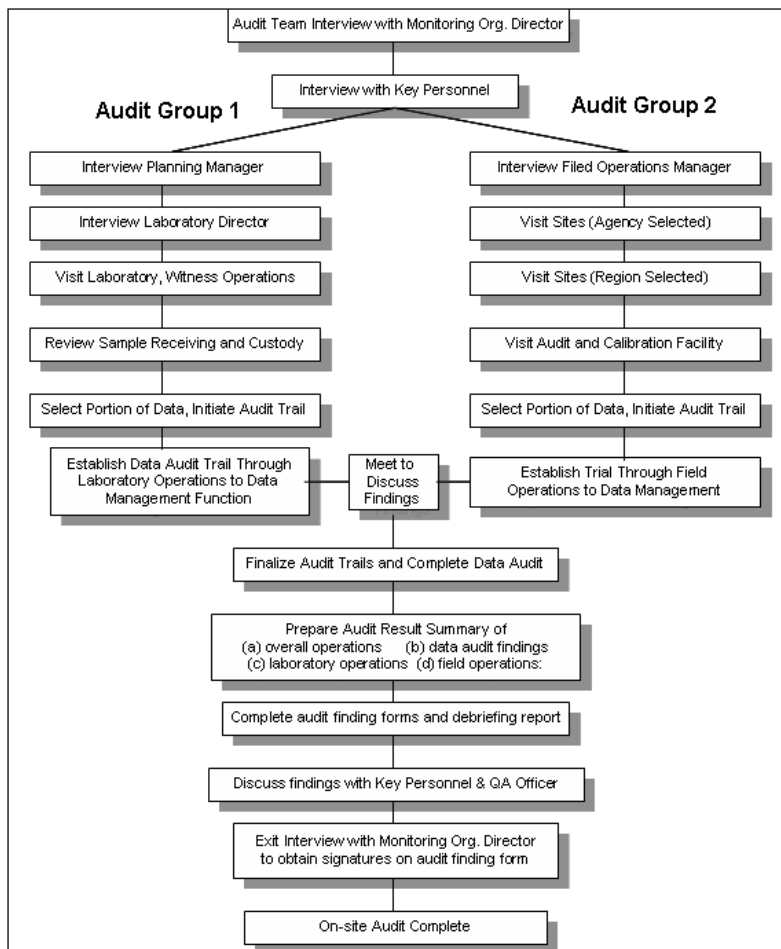

Figure 15.3 On-site audit activities

### 15.3.2. On-Site Activities

The audit team should meet initially with the audited monitoring organization’s director or his/her designee to discuss the scope, duration, and activities involved with the audit. This should be followed by a meeting with key personnel identified from the completed questionnaire, or indicated by the monitoring organization QAO. Key personnel to be interviewed during the audit are those individuals with responsibilities for: planning, field operations, laboratory operations, QA/QC, data management and reporting. At the conclusion of these introductory meetings, the audit team may begin work as two or more independent groups, as illustrated in Figure 15.3. To increase uniformity of site inspections, it is suggested that a site checklist be developed and used. The format for Regional TSAs can be found in Appendix H.

The importance of the audit of data quality (ADQ) cannot be overstated. Thus, sufficient time and effort should be devoted to this activity so that the audit team has a clear understanding and complete documentation of

be devoted to this activity so that the audit team has a clear understanding and complete documentation of



data flow. Its importance stems from the need to have documentation on the quality of ambient air monitoring data for all the criteria pollutants for which the monitoring organization has monitoring requirements. The ADQ will serve as an effective framework for organizing the extensive

**Audit Finding**

**Audit Title:** \_\_\_\_\_ **Audit #:** \_\_\_\_ **Finding #:** \_\_\_\_\_

**Finding:**

**Discussion:**

**QA Lead Signature:** \_\_\_\_\_ **Date:** \_\_\_\_\_

**Audited Agencies Signature:** \_\_\_\_\_ **Date:** \_\_\_\_\_

**Figure 15.4 Audit finding form**

amount of information gathered during the audit of laboratory, field monitoring and support functions within the monitoring organization.

The entire audit team should prepare a brief written summary of findings, organized into the following areas: planning, field operations, laboratory operations, quality assurance/quality control, data management, and reporting. Problems with specific areas should be discussed and an attempt made to rank them in order of their potential impact on data quality. For the more serious problems, audit findings should be drafted (Fig. 15.4).

The audit finding form has been designed such that one is filled out for each major deficiency that requires formal corrective action. They inform the monitoring organization being audited about a serious finding that may compromise the quality of the data and therefore require specific corrective actions. They are initiated by the audit team, and discussed at the debriefing. During the debriefing discussion, evidence may be presented that reduces the significance of the finding; in which case the finding may be

removed. If the audited monitoring organization is in agreement with the finding, the form is signed by the monitoring organization's director or his/her designee during the exit interview. If a disagreement occurs, the QA Team should record the opinions of the monitoring organization audited and set a time at some later date to address the finding at issue.

The audit is now completed by having the audit team members meet once again with key personnel, the QAO and finally with the monitoring organization's director to present their findings. This is also the opportunity for the monitoring organization to present their disagreements.

The audit team should simply state the audit results, including an indication of the potential data quality impact. During these meetings, the audit team should also discuss the systems audit reporting schedule and notify monitoring organization personnel that they will be given a chance to comment in writing, within a certain time period, on the prepared audit report in advance of any formal distribution.

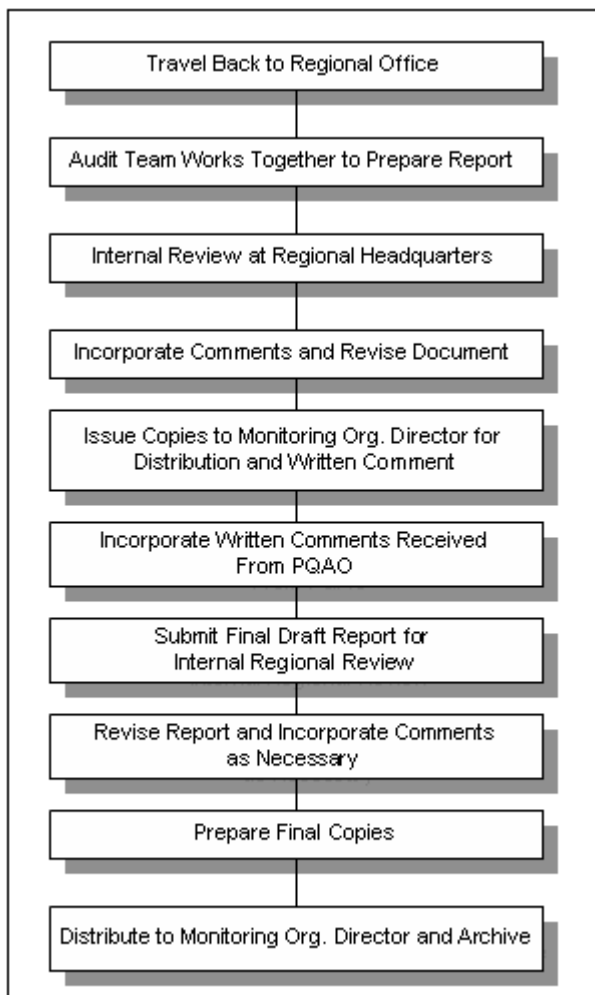

**Figure 15.5 Post-audit activities**

a cover letter be used to reiterate the fact that the audit report is being provided for review and written comment. The letter should also indicate that, should no written comments be received by the audit lead within thirty (30) calendar days from the report date, it will be assumed acceptable to the monitoring organization in its current form, and will be formally distributed without further changes.

### 15.3.3 Post-Audit Activities

The major post-audit activity is the preparation of the systems audit report. The report will include:

- audit title, number and any other identifying information;
- audit team leaders, audit team participants and audited participants;
- background information about the project, purpose of the audit, dates of the audit, particular measurement phase or parameters that were audited, and a brief description of the audit process;
- summary and conclusions of the audit and corrective action requirements; and
- attachments or appendices that include all audit evaluations and audit finding forms.

To prepare the report, the audit team should meet and compare observations with collected documents and results of interviews and discussions with key personnel. Expected QA project plan implementation is compared with observed accomplishments and deficiencies and the audit findings are reviewed in detail. Within thirty (30) calendar days of the completion of the audit, the audit report should be prepared and submitted.

The technical systems audit report is submitted to the audited monitoring organization. It is suggested that

**Audit Finding Response Form**

**Audit Title:** \_\_\_\_\_ **Audit #:** \_\_\_\_\_ **Finding #:** \_\_\_\_\_

**Finding:**

**Cause of the problem:**

**Actions taken or planned for correction:**

**Responsibilities and timetable for the above actions:**

**Prepared by:** \_\_\_\_\_ **Date:** \_\_\_\_\_

**Reviewed by:** \_\_\_\_\_ **Date:** \_\_\_\_\_

**Remarks:**

**Is this audit finding closed?** \_\_\_\_\_ **When?** \_\_\_\_\_

**File with official audit records. Send copy to auditee**

If the monitoring organization has written comments or questions concerning the audit report, the audit team should review and incorporate them as appropriate, and subsequently prepare and resubmit a report in final form within thirty (30) days of receipt of the written comments. Copies of this report should be sent to the monitoring organization director or his/her designee for internal distribution. The transmittal letter for the amended report should indicate official distribution and again draw attention to the agreed-upon schedule for corrective action implementation.

Figure 15.6 Audit response form

### 15.3.4 Follow-up and Corrective Action Requirements

As part of corrective action and follow-up, an audit finding response form (Fig 15.6) is generated by the audited organization for each finding form submitted by the audit team. The audit finding response form is signed by the audited organization's director and sent to the organization responsible for oversight who reviews and accepts the corrective action. The audit response form should be completed by the audited organization within 30 days of acceptance of the audit report.

## 15.4 Data Quality Assessments

A data quality assessment (DQA) is the statistical analysis of environmental data, to determine whether the quality of data is adequate to support the decisions which are based on the DQOs. Data are appropriate if the level of uncertainty in a decision, based on the data, is acceptable. The DQA process is described in detail in the guidance document: *Data Quality Assessment: A Reviewers Guide* (EPA QA/G-9R)<sup>9</sup>, in Section 18 and is summarized below.

- 1) Review the data quality objectives (DQOs) and sampling design of the program: review the DQO and develop one, if it has not already been done. Define statistical hypothesis, tolerance limits, and/or confidence intervals.
- 2) Conduct preliminary data review. Review QA data and other available QA reports, calculate summary statistics, plots and graphs. Look for patterns, relationships, or anomalies.
- 3) Select the statistical test: select the best test for analysis based on the preliminary review, and identify underlying assumptions about the data for that test.
- 4) Verify test assumptions: decide whether the underlying assumptions made by the selected test hold true for the data and the consequences.
- 5) Perform the statistical test: perform test and document inferences. Evaluate the performance for future use.

A companion document to EPA QA/G-R, EPA QA/G-9S document provides many appropriate statistical tests. QAD is also developing statistical software to complement the document. Both can be found on the QAD Homepage (<http://es.epa.gov/ncercqa>).

OAQPS plans on performing data quality assessments for the pollutants of the Ambient Air Quality Monitoring Network at a yearly frequency for data reports and at a 3-year frequency for more interpretative reports. Reporting organizations and State and local monitoring organizations are encouraged to implement data quality assessments at their levels. Attaining the DQOs at a local level will ensure that the DQOs will be met when data is aggregated at higher levels.

---

<sup>9</sup> <http://www.epa.gov/quality1/qs-docs/g9r-final.pdf>

## 16.0 Reports to Management

This section provides guidance and suggestions to air monitoring organizations on how to report the quality of the aerometric data, and how to convey personnel information and requests for assistance concerning quality control and quality assurance problems. The guidance offered here is primarily intended for PQAOs that provide data to one or more of these national networks:

- SLAMS (State and Local Air Monitoring Stations)
- PAMS (Photochemical Air Monitoring Stations)
- PSD (Prevention of Significant Deterioration stations)
- NCore (National Core Monitoring Network)
- Chemical Speciation Network
- NATTS (National Air Toxic Trend Stations)

This guidance may also be useful in preparing reports that summarize data quality of other pollutant measurements such as those made at Special Purpose Monitoring Stations (SPMS) and state-specific programs.

Several kinds of reports can be prepared. The size and frequency of the reports will depend on the information requested or to be conveyed. A brief, corrective action form or letter-style report might ask for attention to an urgent problem. On the other hand, an annual quality assurance report to management would be a much larger report containing sections such as:

- executive summary
- network background and present status
- quality objectives for measurement data
- quality assurance procedures
- results of quality assurance activities, and
- recommendations for further quality assurance work, with suggestions for improving performance and fixing equipment problems, personnel training, infrastructure needs, etc.

A report to management should not solely consist of tabulations of analyzer-by-analyzer precision and bias check results for criteria pollutants. This information is required to be submitted with the data each quarter and is thus already available to management through AQS. Instead, the annual quality assurance report to management should summarize and discuss the results of such checks. These summaries from individual PQAOs can be incorporated into additional reports issued by the state, local, tribal and/or the EPA Regional Office.

This section also provides general information for the preparation of reports to management and includes:

- the types of reports that might be prepared, the general content of each type of report, and a suggested frequency for their preparation
- sources of information that can be tapped to retrieve information for the reports, and
- techniques and methods for concise and effective presentation of information.

Appendix I presents examples of two types of reports to management; the annual quality assurance report to management and a corrective action request.

## 16.1 Guidelines for Preparation of Reports to Management

### 16.1.1 Types of QA Reports to Management

Listed in Table 16-1 are examples of typical QA reports to management. An individual reporting organization may have others to add to the list or may create reports that are combinations of those listed below.

**Table 16-1 Types of QA Reports to Management**

Type of QA Report to Management	Contents	Suggested Reporting Frequency				
		As required	Week	Month	Quarter	Year
Corrective action request	Description of problem; recommended action required; feedback on resolution of problem.	x				
Control chart with summary	Repetitive field or lab activity; control limits versus time. Prepare monthly or whenever new check or calibration samples are used.	x		x	x	x
National Performance Evaluation Program results	Summary of PEP, NPAP, NATTS PT and CSN audit results.	x				x
State and local organization performance audits	Summary of audit results; recommendations for action, as needed.	x				x
Technical systems audits	Summary of system audit results; recommendations for action, as needed.	x				x
Quality assurance report to management	Executive summary. Precision, bias, and system and performance audit results.				x	x
Network reviews (by EPA Regional Office)	Review results and suggestions for actions, as needed.	x				x

### 16.1.2 Sources of Information

Information for inclusion in the various reports to management may come from a variety of sources, including: records of precision and bias checks (AMP255 reports), results of systems and performance audits, laboratory and field instrument maintenance logbooks, NPAP audits, etc. Table 16-2 lists useful sources and the type of information expected to be found.

**Table 16-2 Sources of Information for Preparing Reports to Management**

Information Source	Expected Information and Usefulness
State implementation plan	Types of monitors, locations, and sampling schedule.
Quality assurance program and project plans	Data quality indicators and goals for precision, bias, completeness, timeliness.
Quality objectives for measurement data document	Quality objectives for measurement data. Audit procedures and frequency.
Laboratory and field instrument maintenance logbooks	Record of maintenance activity, synopsis of failures, recommendations for equipment overhaul or replacement.
Laboratory weighing room records of temperature, humidity	A record of whether or not environmental control in the weighing room is adequate to meet goals.
Audit results (NPAP, local, etc.)	Results of audit tests on ambient air pollutant measurement devices.
Quality control data on local information management systems or AQS	Results are generally considered valid and can be used to determine achievement of data quality objectives.

### 16.1.3 Methods of Presenting Information

Reports to management are most effective when the information is given in a succinct, well-summarized fashion. Methods useful for distilling and presenting information in ways that are easy to comprehend are listed in Table 16-3. A 2008 Guidance Document, designed to assist Tribes in developing monitoring programs contains an expanded section (Section 7) that discusses many of the statistical techniques described in Table 16-3<sup>1</sup>. Several of these methods are available on-line in AQS; others are available in commercially available statistical and spreadsheet computer programs.

**Table 16-3 Presentation Methods for Use in Reports to Management**

Presentation Method	Typical Use	Examples
Written text	Description of results and responses to problems	Appendix I
Control chart	Shows whether a repetitive process stays within QC limits.	Figure 10.2 of this Handbook
Black box report	Shows if project goals were met.	Executive Summary of Appendix I
Bar charts	Shows relationships between numerical values.	Included in most graphic and spreadsheet programs
X Y (scatter) charts	Shows relationships between two variables.	Included in most graphic and spreadsheet programs
Probability limit charts and box and whisker plots	Show a numerical value with its associated precision range.	Figure 1 of Appendix I

### 16.1.4 Annual Quality Assurance Report

The annual quality assurance report (an example is provided in Appendix I) should consist of a number of sections that describe the quality objectives for measurement data and how those objectives have been met. A suggested organization might include:

**Executive Summary of Report to Management** - The executive summary should be a short section (no more than two pages) that summarizes the annual quality assurance report to management. It should contain a checklist graphic that lets the reader know how the reporting organization has met its goals for the report period. In addition, a short discussion of future needs and plans should be included.

**Introduction** - This section describes the quality objectives for measurement data and serves as an overview of the reporting organization's structure and functions. It also briefly describes the procedures used by the reporting organization to assess the quality of field and laboratory measurements.

**Quality Information for each Ambient Air Pollutant Monitoring Program** - These sections are organized by ambient air pollutant category (e.g., gaseous criteria pollutants, air toxics). Each section includes the following topics:

- program overview and update
- quality objectives for measurement data
- data quality assessment

<sup>1</sup> Technical Guidance for the Development of Tribal Monitoring Programs  
<http://www.epa.gov/ttn/oarpg/t1/memoranda/techguidancetribalattch.pdf>

### **16.1.5 Corrective Action Request**

A corrective action request should be made whenever anyone in the reporting organization notes a problem that demands either immediate or long-term action to correct a safety defect, an operational problem, or a failure to comply with procedures. A typical corrective action request form, with example information entered, is shown in Appendix I. A separate form should be used for each problem identified.

The corrective action report form is designed as a closed-loop system. First it identifies the originator; the person who reports and identifies the problem, states the problem and may suggest a solution. The form then directs the request to a specific person or persons (i.e., the recipient), who would be best qualified to “fix” the problem. Finally, the form closes the loop by requiring that the recipient state how the problem was resolved and the effectiveness of the solution. The form is signed and a copy is returned to the originator and other copies are sent to the supervisor and the applicable files for the record.



## 17.0 Data Review, Verification and Validation

Data review, verification and validation are techniques used to accept, reject or qualify data in an objective and consistent manner. Verification can be defined as confirmation, through provision of objective evidence that *specified requirements* have been fulfilled<sup>1</sup>. Validation can be defined as confirmation through provision of objective evidence that the particular requirements for a specific *intended use* are fulfilled. It is important to describe the criteria for deciding the degree to which each data item has met its quality specifications as described in an organization's QAPP. This section will describe the techniques used to make these assessments.

In general, these assessment activities are performed by persons implementing the environmental data operations as well as by personnel "independent" of the operation, such as the organization's QA personnel and at some specified frequency. The procedures, personnel and frequency of the assessments should be included in an organization's QAPP. These activities should occur prior to submitting data to AQS and prior to final data quality assessments that will be discussed in Section 18.

Each of the following areas of discussion should be considered during the data review/verification/validation processes. Some of the discussion applies to situations in which a sample is separated from its native environment and transported to a laboratory for analysis and data generation; others are applicable to automated instruments. The following information is an excerpt from *EPA G-5*<sup>2</sup>:

**Sampling Design** - How closely a measurement represents the actual environment at a given time and location is a complex issue that is considered during development of the sampling design. Each sample should be checked for conformity to the specifications, including type and location (spatial and temporal). By noting the deviations in sufficient detail, subsequent data users will be able to determine the data's usability under scenarios different from those included in project planning.

**Sample Collection Procedures**- Details of how a sample is separated from its native time/space location are important for properly interpreting the measurement results. Sampling methods and field SOPs provide these details, which include sampling and ancillary equipment and procedures (including equipment decontamination). Acceptable departures (for example, alternate equipment) from the QAPP, and the action to be taken if the requirements cannot be satisfied, should be specified for each critical aspect. Validation activities should note potentially unacceptable departures from the QAPP. Comments from field surveillance on deviations from written sampling plans also should be noted.

**Sample Handling**- Details of how a sample is physically treated and handled during relocation from its original site to the actual measurement site are extremely important. Correct interpretation of the subsequent measurement results requires that deviations from the sample handling section of the QAPP and the actions taken to minimize or control the changes, be detailed. Data collection activities should indicate events that occur during sample handling that may affect the integrity of the samples. At a minimum, investigators should evaluate the sample containers and the preservation methods used and ensure that they are appropriate to the nature of the sample and the type of data generated from the sample. Checks on the identity of the sample (e.g., proper labeling and chain of custody records) as well as proper physical/chemical storage conditions (e.g., chain of custody and storage records) should be made to ensure that the sample continues to be representative of its native environment as it moves through the analytical process.

---

<sup>1</sup> ISO-9000 [http://www.iso.org/iso/iso\\_catalogue/management\\_standards/iso\\_9000\\_iso\\_14000.htm](http://www.iso.org/iso/iso_catalogue/management_standards/iso_9000_iso_14000.htm)

<sup>2</sup> EPA Guidance to Quality Assurance Project Plans <http://www.epa.gov/quality1/qs-docs/g5-final.pdf>

**Analytical Procedures-** Each sample should be verified to ensure that the procedures used to generate the data were implemented as specified. Acceptance criteria should be developed for important components of the procedures, along with suitable codes for characterizing each sample's deviation from the procedure. Data validation activities should determine how seriously a sample deviated beyond the acceptable limit so that the potential effects of the deviation can be evaluated during DQA.

**Quality Control-** The quality control section of the QAPP specifies the QC checks that are to be performed during sample collection, handling and analysis. These include analyses of check standards, blanks and replicates, which provide indications of the quality of data being produced by specified components of the measurement process. For each specified QC check, the procedure, acceptance criteria, and corrective action (and changes) should be specified. Data validation should document the corrective actions that were taken, which samples were affected, and the potential effect of the actions on the validity of the data.

**Calibration-** Calibration of instruments and equipment and the information that should be presented to ensure that the calibrations:

- were performed within an acceptable time prior to generation of measurement data
- were performed in the proper sequence
- included the proper number of calibration points
- were performed using standards that “bracketed” the range of reported measurement results otherwise, results falling outside the calibration range should be flagged as such
- had acceptable linearity checks and other checks to ensure that the measurement system was stable when the calibration was performed

When calibration problems are identified, any data produced between the suspect calibration event and any subsequent recalibration should be flagged to alert data users.

**Data Reduction and Processing-** Checks on data integrity evaluate the accuracy of “raw” data and include the comparison of important events and the duplicate keying of data to identify data entry errors.

Data reduction may be an irreversible process that involves a loss of detail in the data and may involve averaging across time (for example, 5-minute, hourly or daily averages) or space (for example, compositing results from samples thought to be physically equivalent) such as the Pb sample aggregation or PM<sub>2.5</sub> spatial averaging techniques. Since this summarizing process produces few values to represent a group of many data points, its validity should be well-documented in the QAPP. Potential data anomalies can be investigated by simple statistical analyses.

The information generation step involves the synthesis of the results of previous operations and the construction of tables and charts suitable for use in reports. How information generation is checked, the requirements for the outcome, and how deviations from the requirements will be treated, should be addressed.

## 17.1 Data Review Methods

The flow of data from the field environmental data operations to the storage in the database requires several distinct and separate steps:

- initial selection of hardware and software for the acquisition, storage, retrieval and transmittal of data
- organization and the control of the data flow from the field sites and the analytical laboratory
- input and validation of the data
- manipulation, analysis and archival of the data
- submittal of the data into the EPA's AQS database.

Both manual and computer-oriented systems require individual reviews of all data tabulations. As an individual scans tabulations, there is no way to determine that all values are valid. The purpose of manual inspection is to spot unusually high (or low) values (outliers) that might indicate a gross error in the data collection system. In order to recognize that the reported concentration of a given pollutant is extreme, the individual must have basic knowledge of the major pollutants and of air quality conditions prevalent at the reporting station. Data values considered questionable should be flagged for verification. This scanning for high/low values is sensitive to spurious extreme values but not to intermediate values that could also be grossly in error.

Manual review of data tabulations also allows detection of uncorrected drift in the zero baseline of a continuous sensor. Zero drift may be indicated when the daily minimum concentration tends to increase or decrease from the norm over a period of several days. For example, at most sampling stations, the early morning (3:00 a.m. to 4:00 a.m.) concentrations of carbon monoxide tend to reach a minimum (e.g., 2 to 4 ppm). If the minimum concentration differs significantly from this, a zero drift may be suspected. Zero drift could be confirmed by review of the original strip chart.

In an automated data processing system, procedures for data validation can easily be incorporated into the basic software. The computer can be programmed to scan data values for extreme values, outliers or ranges. These checks can be further refined to account for time of day, time of week, and other cyclic conditions. Questionable data values are then flagged on the data tabulation to indicate a possible error. Other types of data review can consist of preliminary evaluations of a set of data, calculating some basic statistical quantiles and examining the data using graphical representations.

## 17.2 Data Verification Methods

Verification can be defined as confirmation, through provision of objective evidence that *specified requirements* have been fulfilled<sup>3</sup>. The verification requirements for each data operation are included in the organizations' QAPP and in SOPs and should include not only the verification of sampling and analysis processes but also operations like data entry, calculations and data reporting. The data verification process involves the inspection, analysis, and acceptance of the field data or samples. These inspections can take the form of technical systems audits (internal or external) or frequent inspections by

---

<sup>3</sup> Guidance on Environmental Data Verification and Data Validation (QA/G-8) [http://www.epa.gov/quality1/qa\\_docs.html](http://www.epa.gov/quality1/qa_docs.html) through provision of objective evidence

field operators and lab technicians. Questions that might be asked during the verification process include:

- Were the environmental data operations performed according to the SOPs governing those operations?
- Were the environmental data operations performed on the correct time and date originally specified? Many environmental operations must be performed within a specific time frame; for example, the NAAQS samples for particulates are collected once every six days from midnight to midnight. The monitor timing mechanisms must have operated correctly for the sample to be collected within the time frame specified.
- Did the sampler or monitor perform correctly? Individual checks such as leak checks, flow checks, meteorological influences, and all other assessments, audits, and performance checks must have been acceptably performed and documented.
- Did the environmental sample pass an initial visual inspection? Many environmental samples can be flagged (qualified) during the initial visual inspection.
- Have manual calculations, manual data entry, or human adjustments to software settings been checked? Automated calculations should be verified and accepted prior to use, but at some frequencies these calculations should be reviewed to ensure that they have not changed.
- Were the environmental data operations performed to meet data quality objectives designed for those specific data operations and were the operations performed as specified? The objectives for environmental data operations must be clear and understood by all those involved with the data collection.

### 17.3 Data Validation Methods

Data validation is a routine process designed to ensure that reported values meet the quality goals of the environmental data operations. Data validation is further defined as examination and provision of objective evidence that the particular requirements for a specific *intended use* are fulfilled. A progressive, systematic approach to data validation must be used to ensure and assess the quality of data.

The purpose of data validation is to detect and then verify any data values that may not represent actual air quality conditions at the sampling station. Effective data validation procedures usually are handled completely independently from the procedures of initial data collection.

Because the computer can perform computations and make comparisons extremely rapidly, it can also make some determination concerning the validity of data values that are not necessarily high or low. Data validation procedures should be recommended as standard operating procedures. For example, one can evaluate the difference between successive data values, since one would not normally expect very rapid changes in concentrations of a pollutant during a 5-min or 1-h reporting period. When the difference between two successive values exceeds a predetermined value, the tabulation can be flagged, with an appropriate symbol.

Quality control data can support data validation procedures (see section 17.3.3). If data assessment results clearly indicate a serious response problem with the analyzer, the agency should review all pertinent quality control information to determine whether any ambient data, as well as any associated assessment data, should be invalidated. Therefore if ambient data are determined to be invalid, then the associated precision, bias and accuracy readings should also be invalidated. Any data quality calculations

using the invalidated readings should be redone. Also, the precision, bias or accuracy checks should be rescheduled, preferably in the same calendar quarter. The basis or justification for all data invalidations should be permanently documented.

Certain criteria, based upon CFR and field operator and laboratory technician judgment, may be used to invalidate a sample or measurement. These criteria should be explicitly identified in the organization's QAPP. Many organizations use flags or result qualifiers to identify potential problems with data or a sample. A flag is an indicator of the fact and the reason that a data value (a) did not produce a numeric result, (b) produced a numeric result but it is qualified in some respect relating to the type or validity of the result, or (c) produced a numeric result but for administrative reasons is not to be reported outside the organization. Flags can be used both in the field and in the laboratory to signify data that may be suspect due to contamination, special events or failure of QC limits. Flags can be used to determine if individual samples (data), or samples from a particular instrument, will be invalidated. In all cases, the sample (data) should be thoroughly reviewed by the organization prior to any invalidation.

Flags may be used alone or in combination to invalidate samples. Since the possible flag combinations can be overwhelming and can not always be anticipated, an organization needs to review these flag combinations and determine if single values or values from a site for a particular time period will be invalidated. The organization should keep a record of the combination of flags that resulted in invalidating a sample or set of samples. These combinations should be reported to the EPA Region and can be used to ensure that the organization evaluates and invalidates data in a consistent manner.

Procedures for screening data for possible errors or anomalies should also be implemented. The data quality assessment document series (EPA QA/G-9R<sup>4</sup>, EPA QA/G-9s<sup>5</sup>) provide several statistical screening procedures for ambient air quality data that should be applied to identify gross data anomalies.

**NOTE:** it is strongly suggested that flags, specifically the appropriate null data code flags, be used in place of any routine values that are invalidated. This provides some indication to data users and data quality assessors to the reasons why data that was expected to be collected was missing.

### 17.3.1 Automated Methods

When zero, span or one-point QC checks exceed acceptance limits, ambient measurements should be invalidated back to the most recent point in time where such measurements are known to be valid. Usually this point is the previous check, unless some other point in time can be identified and related to the probable cause of the excessive drift or exceedance (such as a power failure or malfunction). Also, data following an analyzer malfunction or period of non-operation should be regarded as invalid until the next subsequent (level 1) acceptable check or calibration. Based on the sophistication of DAS (see Section 14) monitoring organization may have other automated programs for data validation. These programs should be described in the monitoring organization's approved QAPP prior to implementation. Even though the automated technique may be considered acceptable, the raw invalidated data should be archived for statute of limitations discussed in Section 5.

---

<sup>4</sup> Data Quality Assessment: A Reviewer's Guide <http://www.epa.gov/quality1/qs-docs/g9r-final.pdf>

<sup>5</sup> Data Quality Assessment: Statistical Methods for Practitioners <http://www.epa.gov/quality1/qs-docs/g9s-final.pdf>

### 17.3.2 Manual Methods

For manual methods, the first level of data validation should be to accept or reject monitoring data based upon results from operational checks selected to monitor the critical parameters in all three major and distinct phases of manual methods--sampling, analysis, and data reduction. In addition to using operational checks for data validation, the user must observe all limitations, acceptance limits, and warnings described in the reference and equivalent methods per se that may invalidate data. It is further recommended that results from performance audits/evaluations required in 40 CFR 58, Appendix A not be used as the sole criteria for data invalidation because these checks (performance audits) are intended to assess the quality of the data.

### 17.3.3 Validation Templates

In June 1998, a workgroup was formed to develop a procedure that could be used by monitoring organizations that would provide for a consistent validation of PM<sub>2.5</sub> mass concentrations across the US. The Workgroup developed three tables of criteria where each table has a different degree of implication about the quality of the data. The criteria included on the tables are from 40 CFR Part 50, Appendices L and N, 40 CFR Part 58, Appendix A, Method 2.12, and a few criteria that are neither in CFR nor Method 2.12.

One of the tables has the criteria that *must* be met to ensure the quality of the data. An example criterion is that the average flow rate for the sampling period must be maintained to within 5% of 16.67 liters per minute. The second table has the criteria that indicate that there *might* be a problem with the quality of the data and further investigation is warranted before making a determination about the validity of the sample or samples. An example criterion is that the field filter blanks should not change weight by more than 30 $\mu$ g between weighings. The third table has criteria that indicate a potentially systematic problem with the environmental data collection activity. Such systematic problems may impact the ability to make decisions with the data. An example criterion is that at least 75% of the scheduled samples for each quarter should be successfully collected and validated.

To determine the appropriate table for each criterion, the members of the workgroup considered how significantly the criteria impact the resulting PM<sub>2.5</sub> mass. This was based on experience from workgroup members, experience from non-workgroup members, and feasibility of implementing the criterion.

Criteria that were deemed critical to maintaining the integrity of a sample or group of samples were placed on the first table. Observations that do not meet each and every criterion on the **Critical Criteria Table** should be invalidated unless there are compelling reason and justification for not doing so. Basically, the sample or group of samples for which one or more of these criteria are not met is invalid until proven otherwise. The cause of not operating in the acceptable range for each of the violated criteria must be investigated and minimized to reduce the likelihood that additional samples will be invalidated.

Criteria that are important for maintaining and evaluating the quality of the data collection system are included on the second table, the **Operational Criteria Table**. Violation of a criterion or a number of criteria may be cause for invalidation. The decision should consider other quality control information that may or may not indicate the data are acceptable for the parameter being controlled. Therefore, the sample or group of samples for which one or more of these criteria are not met is suspect unless other quality

control information demonstrates otherwise. The reason for not meeting the criteria **MUST** be investigated, mitigated or justified.

Finally, those criteria which are important for the correct interpretation of the data but do not usually impact the validity of a sample or group of samples are included on the third table, the **Systematic Criteria Table**. For example, the data quality objectives are included in this table. If the data quality objectives are not met, this does not invalidate any of the samples but it may impact the error rate associated with the attainment/non-attainment decision.

Based on the success and use of the PM<sub>2.5</sub> validation template, the Workgroup embarked on the development of similar templates for the remaining criteria pollutants. Appendix D provides templates for each criteria pollutant. The validation templates are based on the current state of knowledge at the time of development of the Handbook. The template will evolve as new information is discovered about the impact of the various criterion on the error in the resulting concentration estimate. Interactions of the criteria, whether synergistic or antagonistic, should also be incorporated when the impact of these interactions becomes quantified. Due to the potential misuse of invalid data, data that are invalidated will not be uploaded to AQS but should be retained on the monitoring organizations local database. This data will be invaluable to the evolution of the validation template.

**NOTE:** Strict adherence to the validation templates is not required. They are meant to be a guide based upon the knowledge of the Workgroup who developed them and may be a starting point for monitoring organization specific validation requirement.

## 18.0 Reconciliation with Data Quality Objectives

Section 3 described the data quality objective (DQO) process, which is an important planning tool to determine the objectives of an environmental data operation, to understand and agree upon the allowable uncertainty in the data and, with that, to optimize the sampling design. This information, along with sampling and analytical methods and appropriate QA/QC, should be documented in an organization's QAPP. The QAPP is then implemented by the monitoring organizations under the premise that if it is followed, the DQOs should be met. Reconciliation with the DQO involves reviewing both routine and QA/QC data to determine whether the DQOs have been attained and that the data are adequate for their intended use. This process of evaluating the data against the DQOs has been termed data quality assessment (DQA).

The DQA process has been developed for cases where formal DQOs have been established. However, these procedures can also be used for data that do not formally have DQOs. Guidance on the DQA process can be found in the documents titled *Data Quality Assessment: A Reviewer's Guide (EPA QA/G-9R)*<sup>1</sup> and its companion document *Data Quality Assessment: Statistical Tools for Practitioners (EPA QA/G-9S)*<sup>2</sup>. This document focuses on evaluating data for fitness in decision-making and also provides many graphical and statistical tools.

As stated in EPA QA/G-9R "*Data quality, as a concept, is meaningful only when it relates to the intended use of the data*". By using the DQA Process, one can answer four fundamental questions:

1. Can the decision (or estimate) be made with the desired level of certainty, given the quality of the data set?
2. How well did the sampling design perform?
3. If the same sampling design strategy is used again for a similar study, would the data be expected to support the same intended use with the desired level of uncertainty?
4. Is it likely that sufficient samples were taken to enable the reviewer to see an effect if it was really present?

DQA is a key part of the assessment phase of the data life cycle (Figure 18.1), which is very similar to the ambient air QA life cycle described in Section 1. As the part of the assessment phase that follows data validation and verification, DQA determines how well the validated data can support their intended use.

### 18.1 Five Steps of the DQA Process

As described in *EPA QA/G-9R*<sup>1</sup> and *EPA QA/G-9S*<sup>2</sup>, the DQA process is comprised of five steps. The steps are detailed below. Since DQOs are available for the PM<sub>2.5</sub> program, they will be used as an example for the type of information that might be considered in each step. The PM<sub>2.5</sub> information is italicized and comes from a model PM<sub>2.5</sub> QAPP<sup>3</sup> for a fictitious reporting organization called Palookaville. The model QAPP was developed to help monitoring organizations develop QAPPs based upon the new R-5 QAPP requirements.

---

<sup>1</sup> <http://www.epa.gov/quality1/qs-docs/g9r-final.pdf>

<sup>2</sup> <http://www.epa.gov/quality1/qs-docs/g9s-final.pdf>

<sup>3</sup> <http://www.epa.gov/ttn/amtic/pmqaainf.html>



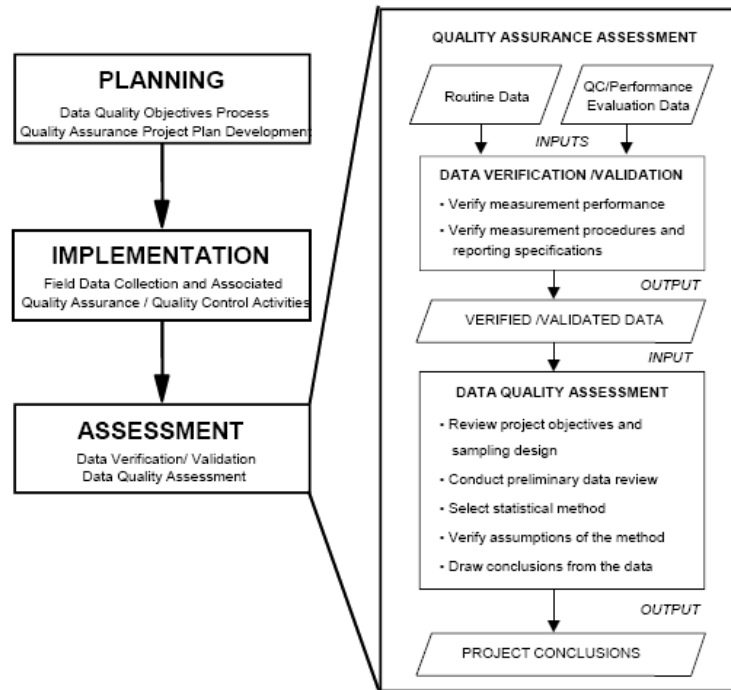

Figure 18.1 DQA in the context of data life cycle.

**Step 1. Review DQOs and Sampling Design.** Review the DQO outputs to assure that they are still applicable. If DQOs have not been developed, specify DQOs before evaluating the data (e.g., for environmental decisions, define the statistical hypothesis and specify tolerable limits on decision errors; for estimation problems, define an acceptable confidence probability interval width). Review the sampling design and data collection documentation for consistency with the DQOs observing any potential discrepancies.

*The  $PM_{2.5}$  DQOs define the primary objective of the  $PM_{2.5}$  ambient air monitoring network ( $PM_{2.5}$  NAAQS comparison), translate the objective into a statistical hypothesis (3-year average of annual mean  $PM_{2.5}$  concentrations less than or equal to  $15 \mu\text{g}/\text{m}^3$  and 3-year average of annual 98th percentiles of the  $PM_{2.5}$  concentrations less than or equal to  $35 \mu\text{g}/\text{m}^3$ ), and identify limits on the decision errors (incorrectly conclude area in non-attainment when it truly is in attainment no more than 5% of the time, and incorrectly conclude area in attainment when it truly is in non-attainment no more than 5% of the time).*

*The CFR contains the details for the sampling design, including the rationale for the design, the design assumptions, and the sampling locations and frequency. If any deviations from the sampling design have occurred, these will be indicated and their potential effect carefully considered throughout the entire DQA.*

**Step 2. Conduct Preliminary Data Review.** Review QA reports, calculate basic statistics, and generate graphs of data. Use this information to understand the structure of the data and identify patterns, relationships, or potential anomalies.

*A preliminary data review will be performed to uncover potential limitations of using the data, to reveal outliers, and generally to explore the basic structure of the data. The first step is to review the quality assurance reports. The second step is to calculate basic summary statistics, generate graphical presentations of the data, and review these summary statistics and graphs.*

**Review Quality Assurance Reports.** *Palookaville will review all relevant quality assurance reports that describe the data collection and reporting process. Particular attention will be directed to looking for anomalies in recorded data, missing values, and any deviations from standard operating procedures. This is a qualitative review. However, any concerns will be further investigated in the next two steps.*

**Calculation of Summary Statistics and Generation of Graphical Presentations.** *Palookaville will generate prominent summary statistics for each of its primary and QA samplers. These summary statistics will be calculated at the quarterly, annual, and three-year levels and will include only valid samples. The summary statistics are:*

*Number of samples, mean concentration, median concentration, standard deviation, coefficient of variation, maximum concentration, minimum concentration, interquartile range, skewness and kurtosis.*

*These statistics will also be calculated for the percent differences at the collocated sites. The results will be summarized in a table. Particular attention will be given to the impact on the statistics caused by the observations noted in the quality assurance review. For example, Palookaville may evaluate the influence of a potential outlier by evaluating the change in the summary statistics resulting from exclusion of the outlier.*

*Palookaville will generate graphics to present the results from the summary statistics and show the spatial continuity over the sample areas. Maps will be created for the annual and three-year means, maxima, and interquartile ranges for a total of 6 maps. The maps will help uncover potential outliers and will help in the network design review. Additionally, basic histograms will be generated for each of the primary and QA samplers and for the percent difference at the collocated sites. The histograms will be useful in identifying anomalies and evaluating the normality assumption in the measurement errors.*

**Step 3. Select the Statistical Test.** *Select the most appropriate procedure for summarizing and analyzing the data, based upon the reviews of the performance and acceptance criteria associated with the DQOs, the sampling design, and the preliminary data review. Identify the key underlying assumptions that must hold for the statistical procedures to be valid.*

*The primary objective for the PM<sub>2.5</sub> mass monitoring is determining compliance with the PM<sub>2.5</sub> NAAQS. As a result, the null and alternative hypotheses are:*

$$H_0 : X \leq 15 \mu\text{g} / \text{m}^3 \text{ and } Y \leq 35 \mu\text{g} / \text{m}^3$$

$$H_A : X > 15 \mu\text{g} / \text{m}^3 \text{ or } Y > 35 \mu\text{g} / \text{m}^3$$

*where X is the three-year average PM<sub>2.5</sub> concentration and Y is the three-year average of the annual 98th percentiles of the PM<sub>2.5</sub> concentrations recorded for an individual monitor. The exact calculations for X and Y are specified in 40 CFR Part 50, Appendix N. The null hypothesis is rejected; that is, it is concluded that the area is not in compliance with the PM<sub>2.5</sub> NAAQS when the observed three-year average of the annual arithmetic mean concentration exceeds 15.05  $\mu\text{g}/\text{m}^3$  or when the observed*

three-year average of the annual 98th percentiles exceeds  $35.5 \mu\text{g}/\text{m}^3$ . If the bias of the sampler is  $\pm 10\%$  and the precision is within 10%, then the error rates (Type I and Type II) associated with this statistical test are less than or equal to 5%. The definitions of bias and precision will be outlined in the following step.

**Step 4. Verify Assumptions of Statistical Test.** Evaluate whether the underlying assumptions hold, or whether departures are acceptable, given the actual data and other information about the study.

*The assumptions behind the statistical test include those associated with the development of the DQOs in addition to the bias and precision assumptions. The method of verification will be addressed in this step. Note that when less than three years of data are available, this verification will be based on as much data as are available.*

**The DQO is based on the annual arithmetic mean NAAQS.** For each primary sampler, Palookaville will determine which, if either, of the  $\text{PM}_{2.5}$  NAAQS concentration is violated. In the DQO development, it was assumed that the annual standard is more restrictive than the 24-hour standard. If there are any samplers that violate ONLY the 24-hour NAAQS, then this assumption is not correct. The seriousness of violating this assumption is not clear. Conceptually, the DQOs can be developed based on the 24-hour NAAQS and the more restrictive bias and precision limits selected. However, Palookaville will assume the annual standard is more restrictive, until proven otherwise.

**Normal distribution for measurement error.** Assuming that measurement errors are normally distributed is common in environmental monitoring. Palookaville has not investigated the sensitivity of the statistical test to violate this assumption; although, small departures from normality generally do not create serious problems. Instead, Palookaville will evaluate the reasonableness of the normality assumption by reviewing a normal probability plot, and calculating the Shapiro-Wilk W Test statistic (if sample size less than 50) or calculating the Kolmogorov-Smirnoff Test statistic (if sample size greater than 50). All three techniques are provided by standard statistical packages. If the plot or statistics indicate possible violations of normality, Palookaville may need to determine the sensitivity of the DQOs to departures in normality.

Decision error can occur when the estimated 3-year average differs from the actual (true) 3-year average. This is not really an assumption as much as a statement that the data collected by an ambient air monitor is stochastic, meaning that there are errors in the measurement process, as mentioned in the previous assumption.

The limits on precision and bias are based on the smallest number of required sample values in a 3-year period. In the development of the DQOs, the smallest number of required samples was used. The reason for this was to ensure that the confidence was sufficient in the minimal case; if more samples are collected, then the confidence in the resulting decision will be even higher. For each of the samplers, Palookaville will determine how many samples were collected in each quarter. If this number meets or exceeds 12, then the data completeness requirements for the DQO are met.

The decision error limits were set at 5%. If the other assumptions are met, then the decision error limits are less than or equal to 5%.

Measurement imprecision was established at 10% coefficient of variation (CV). For each sampler, Palookaville will review the coefficient of variation calculated in Step 2. If any exceed 10%, Palookaville may need to determine the sensitivity of the DQOs to larger levels of measurement imprecision.

Table 18-1 will be completed during each DQA. The table summarizes which, if any, assumptions have been violated. A check will be placed in each of the row/column combinations that apply. Ideally, there will be no checks. However, if there are checks in the table, the implication is that the decision error rates are unknown, even if the bias and precision limits are achieved. As mentioned above, if any of the DQO assumptions are violated, then Palookaville will need to reevaluate its DQOs.

**Achievement of bias and precision limits.** Lastly, Palookaville will check the assumption that at the 3-year level of aggregation, the sampler bias is within  $\pm 10\%$  and precision is  $< 10\%$ . The data from the collocated samplers will be used to calculate quarterly, annual, and 3-year bias and precision estimates even though it is only the 3-year estimates that are critical for the statistical test.

Since all the initial samplers being deployed by Palookaville will be FRMs, the samplers at each of the collocated sites will be identical method designations. As such, it is difficult to determine which of the collocated samplers is closer to the true  $PM_{2.5}$  concentration. Palookaville will calculate an estimate of precision. A bias measure will also be calculated, but it can only describe the relative difference of one sampler to the other, not definitively indicate which sampler is closer to the "true" value. The following paragraphs contain the algorithms for calculating precision and bias. These are similar, but differ slightly, from the equations in 40 CFR Part 58, Appendix A.

**Table 18-1 Summary of Violations of DQO Assumptions**

Site	Violate 24-Hour Standard ONLY?	Measurement Errors Non-Normal?	Data Complete? ( $\geq 12$ samples per quarter)	Measurement CV $> 10\%$ ?
Primary Samplers				
A1				
A2				
A3				
A4				
B1				
QA Samplers				
A1				
B1				

Before describing the algorithm, some ground work is necessary. When less than three years of collocated data are available, then the three-year bias and precision estimates must be predicted. Palookaville's strategy for accomplishing this will be to use all available quarters of data as the basis for projecting where the bias and precision estimates will be at the end of the three-year monitoring period. Three-year point estimates will be computed by weighting the quarterly components, using the most applicable of the following assumptions:

1. Most recent quarter's precision and bias are most representative of what the future quarters will be.
2. All previous quarters precision and bias are equally representative of what the future quarter's will be.
3. Something unusual happened in the most recent quarter, so the most representative quarters are all the previous ones, minus the most recent.

Each of these scenarios results in weights that will be used in the following algorithms. The weights are shown in Table 18-2 where the variable  $Q$  represents the number of quarters for which observed bias and precision estimates are available. Note that when  $Q=12$ , that is, when there are bias and precision values for all of the quarters in the three-year period, then all of the following scenarios result in the same weighting scheme.

**Table 18-2 Weights for Estimating Three-Year Bias and Precision**

Scenario	Assumption	Weights
1	Latest quarter most representative	$w_q = 12-(Q-1)$ for latest quarter, $w_q = 1$ otherwise
2	All quarters equally representative	$w_q = 12/Q$ for each quarter
3	Latest quarter unrepresentative	$w_q = 1$ for latest quarter, $w_q = 11/(Q-1)$ otherwise

In addition to point estimates, Palookaville will develop confidence intervals for the bias and precision estimates. This will be accomplished using a re-sampling technique. The protocol for creating the confidence intervals are outlined in Box 18.1.

**Box 18.1 Method for Estimating Confidence in Achieving Bias and Precision DQOs**

Let  $Z$  be the statistic of interest (bias or precision). For a given weighting scenario, the re-sampling will be implemented as follows:

1. Determine  $M$ , the number of collocated pairs per quarter for the remaining  $12-Q$  quarters (default is  $M=15$  or can use  $M$ =average number observed for the previous  $Q$  quarters).
  2. Randomly select with replacement  $M$  collocated pairs per quarter for each of the future  $12-Q$  quarters in a manner consistent with the given weighting scenario.
    - Scenario 1: Select pairs from latest quarter only.
    - Scenario 2: Select pairs from any quarter.
    - Scenario 3: Select pairs from any quarter except the latest one.
- Result from this step is “complete” collocated data for a three-year period, from which bias and precision estimates can be determined.
3. Based on the “filled-out” three-year period from step 2, calculate three-year bias and precision estimate, using Equation 1 where  $w_q = 1$  for each quarter.
  4. Repeat steps 2 and 3 numerous times, such as 1000 times.
  5. Determine  $P$ , the fraction of the 1000 simulations for which the three-year bias and precision criteria are met.  $P$  is interpreted as the probability that the sampler is generating observations consistent with the three-year bias and precision DQOs.

The algorithms for determining whether the bias and precision DQOs have been achieved for each sampler follow:

**Bias Algorithm**

1. For each measurement pair, estimate the percent relative bias,  $d_i$ ,

$$d_i = \frac{Y_i - X_i}{(Y_i + X_i)/2} \times 100 \%$$

where  $X_i$  represents the concentration recorded by the primary sampler and  $Y_i$  represents the concentration recorded by the collocated sampler.

2. Summarize the percent relative bias to the quarterly level,  $D_{j,q}$ , according to

$$D_{j,q} = \frac{1}{n_{j,q}} \sum_{i=1}^{n_{j,q}} d_i$$

where  $n_{j,q}$  is the number of collocated pairs in quarter  $q$  for site  $j$ .

3. Summarize the quarterly bias estimates to the three-year level using

$$\hat{D}_j = \frac{\sum_{q=1}^{n_q} w_q D_{j,q}}{\sum_{q=1}^{n_q} w_q} \quad \text{Equation 18-1}$$

where  $n_q$  is the number of quarters with actual collocated data and  $w_q$  is the weight for quarter  $q$  as specified by the scenario in Table 18-2.

4. Examine  $D_{j,q}$  to determine whether one sampler is consistently measuring above or below the other. To formally test this, a non-parametric test will be used (Wilcoxon Signed Rank Test), which is described in EPA QA/G-9S<sup>2</sup>. If the null hypothesis is rejected, then one of the samplers is consistently measuring above or below the other. This information may be helpful in directing the investigation into the cause of the bias.

**Precision Algorithm**

1. For each measurement pair, calculate the coefficient of variation,  $cv_i$ ,

$$cv_i = \frac{|d_i|}{\sqrt{2}}$$

- Summarize the coefficient of variation to the quarterly level,  $CV_{j,q}$  according to

$$CV_{j,q} = \sqrt{\frac{\sum_{i=1}^{n_{j,q}} CV_i^2}{n_{j,q}}}$$

where  $n_{j,q}$  is the number of collocated pairs in quarter  $q$  for site  $j$ .

- Summarize the quarterly precision estimates to the three-year level using

$$\hat{CV}_j = \sqrt{\frac{\sum_{q=1}^{n_q} (w_q CV_{j,q}^2)}{\sum_{q=1}^{n_q} w_q}} \quad \text{Equation 18-2}$$

where  $n_q$  is the number of quarters with actual collocated data and  $w_q$  is the weight for quarter  $q$  as specified by the scenario in Table 24-2 (reference to Model QAPP).

- If the null hypothesis in the Wilcoxon Signed Rank Test was not rejected, then the coefficient of variation can be interpreted as a measure of precision. If the null hypothesis in the Wilcoxon Signed Rank Test was rejected, the coefficient of variation has both a component representing precision and a component representing the (squared) bias.

**Confidence in Bias and Precision Estimates**

- Follow the method described in Box 18.1 to estimate the probability that the sampler is generating observations consistent with the three-year bias and precision DQOs. The re-sampling must be done for each collocated site.

**Summary of Bias and Precision Estimation**

The results from the calculations and re-sampling will be summarized in Table 18-3. There will be one line for each site operating a collocated sampler.

**Table 18-3 Summary of Bias and Precision**

Collocated	Three-year Bias Estimate (Equation. 1)	Three-year Precision Estimate (Equation. 2)	Null Hypothesis of Wilcoxon Test Rejected?	P (Box 18-1)
AI				
BI				

**Step 5. Draw Conclusions from the Data.** Perform the calculations required for the statistical test and document the inferences drawn as a result of these calculations. If the design is to be used again, evaluate the performance of the sampling design.

*Before determining whether the monitored data indicate compliance with the  $PM_{2.5}$  NAAQS, Palookaville must first determine if any of the assumptions upon which the statistical test is based are violated. This can be easily checked in Step 5 because of all the work done in Step 4. In particular, as long as*

- *in Table 18-1, there are no checks, and*
- *in Table 18-3,*
  - *the three year bias estimate is in the interval [-10%,10%], and*
  - *the three year precision estimate is less than or equal to 10%*

*then the assumptions underlying the test appear to be valid. As a result, if the observed three-year average  $PM_{2.5}$  concentration is less than  $15 \mu\text{g}/\text{m}^3$  and the observed three-year average 98th percentile is less than  $35 \mu\text{g}/\text{m}^3$ , the conclusion is that the area seems to be in compliance with the  $PM_{2.5}$  NAAQS, with an error rate of 5%.*

*If any of the assumptions have been violated, then the level of confidence associated with the test is suspect and will have to be further investigated.*

### **DQA without DQOs**

Even though DQOs, based upon the EPA G-4 guidance, have not been developed for all criteria pollutants, a process very similar to this approach was originally used<sup>4</sup>. In addition, monitoring organizations collect enough types of QA/QC data to estimate the quality of their data and should be able to express the confidence in that information.

---

<sup>4</sup> Curran, Thomas C. et.al., "Establishing Data Quality Acceptance Criteria for Air Pollution Data" Transactions of the 35 Annual Conference of the American Society for Quality Control (May 27-29,1981)



## **Appendix A**

### **National Air Quality Monitoring Program Fact Sheets**

**The following information provides a fact sheet on a number of national ambient air monitoring networks including:**

- **State or Local Air Monitoring Stations (SLAMS) Network**
- **National Core (NCore) Network**
- **Photochemical Assessment Monitoring Stations (PAMS)**
- **PM<sub>2.5</sub> Chemical Speciation Network (CSN)**
- **National Toxics Trends Network (NATTS)**
- **Interagency Monitoring of Protected Visual Environments (IMPROVE)**
- **Clean Air Status and Trends Network (CASTNET)**
- **National Atmospheric Deposition Network (NADP)**
- **National Air Toxics Assessment (NATA)**

**Only the SLAMS, NCore, PAMS, CSN and NATTS pertain to the information covered in the Handbook. The other networks described are for the benefit of the reader.**

*Page intentionally left blank*

## State or Local Air Monitoring Stations (SLAMS) Network

### Background

The SLAMS make up the ambient air quality monitoring sites that are operated by State or local agencies for the primary purpose of comparison to the National Ambient Air Quality Standards (NAAQS), but may serve other purposes such as:

- provide air pollution data to the general public in a timely manner;
- support compliance with air quality standards and emissions strategy development; and
- support air pollution research studies.

The SLAMS network includes stations classified as NCore, PAMS, and Speciation, and formerly categorized as NAMS, and does not include Special Purpose Monitors (SPM) and other monitors used for non-regulatory or industrial monitoring purposes.

In order to support the objectives, the monitoring networks are designed with a variety of monitoring sites that generally fall into the following categories which are used to determine:

1. the highest concentrations expected to occur in the area covered by the network;
2. typical concentrations in areas of high population density;
3. the impact on ambient pollution levels of significant sources or source categories;
4. the general background concentration levels;
5. the extent of regional pollutant transport among populated areas, and in support of secondary standards; and
6. air pollution impacts on visibility, vegetation damage, or other welfare- based impacts.

The monitoring aspects of the SLAMS program are found in the Code of Federal Regulations, Title 40, Parts 50, 53 and 58.

SLAMS must use approved Federal reference method (FRM), Federal equivalent method (FEM), or Approved Regional Method (ARM) monitors for ambient pollutant levels being compared to the NAAQS.

Reference Category	References	Comments
Program References	40 CFR Part 50, 53 and 58 <a href="http://www.epa.gov/ttn/amtic/">http://www.epa.gov/ttn/amtic/</a>	
Pollutants Measured	O <sub>3</sub> , CO, SO <sub>2</sub> , NO <sub>2</sub> , PM <sub>2.5</sub> , PM <sub>10</sub> , Pb	
Methods References	40 CFR Part 50 and 58 Appendix C <a href="http://www.epa.gov/ttn/amtic/criteria.html">http://www.epa.gov/ttn/amtic/criteria.html</a>	Must be FRM, FEM, or ARM for NAAQS comparisons. Website lists designated methods
Network Design References	40 CFR Part 58 Appendix D, E	
Siting Criteria	40 CFR Part 58 Appendix E	
Quality System References	40 CFR Part 58 Appendix A <a href="http://www.epa.gov/ttn/amtic/quality.html">http://www.epa.gov/ttn/amtic/quality.html</a> <a href="http://www.epa.gov/ttn/amtic/met.html">http://www.epa.gov/ttn/amtic/met.html</a>	Website for QA Handbook Vol II Ebsite for QA Handbook Vol IV
Data Management References	<a href="http://www.epa.gov/ttn/airs/airsaqs/">http://www.epa.gov/ttn/airs/airsaqs/</a>	Air Quality System

## National Core (NCore) Network

### Background

The NCore multi-pollutant stations are part of an overall strategy to integrate multiple monitoring networks and measurements. As required by the revised monitoring regulations promulgated in 2006, monitors at NCore multi-pollutant sites will measure particles (PM<sub>2.5</sub>, speciated PM<sub>2.5</sub>, PM<sub>10-2.5</sub>, speciated PM<sub>10-2.5</sub>), O<sub>3</sub>, SO<sub>2</sub>, CO, nitrogen oxides (NO/NO<sub>2</sub>/NO<sub>y</sub>), and basic meteorology. Monitors for all the gases except for O<sub>3</sub> will be more sensitive than standard FRM/FEM monitors, so they could accurately report concentrations that are well below the respective NAAQS but that can be important in the formation of O<sub>3</sub> and PM.

The objective is to locate sites in broadly representative urban (about 55 sites) and rural (about 20 sites) locations throughout the country to help characterize regional and urban patterns of air pollution. The NCore network must be fully operational by 2011. Many stations will be operational before that deadline.

In many cases, states will collocate these new stations with STN sites measuring speciated PM<sub>2.5</sub> components, PAMS sites already measuring O<sub>3</sub> precursors, and/or NATTS sites measuring air toxics. By combining these monitoring programs at a single location, EPA and its partners will maximize the multi-pollutant information available. This greatly enhances the foundation for future health studies, NAAQS revisions, validation of air quality models, assessment of emission reduction programs, and studies of ecosystem impacts of air pollution.

Reference Category	References	Comments
Program References	<a href="http://www.epa.gov/ttn/amtic/monitor.html">http://www.epa.gov/ttn/amtic/monitor.html</a>	
Pollutants Measured	SO <sub>2</sub> , CO, NO and NO <sub>y</sub> , and O <sub>3</sub> , PM <sub>2.5</sub> , PM <sub>10-2.5</sub> , basic meteorological parameters	
Methods References	<a href="http://www.epa.gov/ttn/amtic/precursop.html">http://www.epa.gov/ttn/amtic/precursop.html</a> <a href="http://www.epa.gov/ttn/amtic/pretecdoc.html">http://www.epa.gov/ttn/amtic/pretecdoc.html</a>	
Network Design References	<a href="http://www.epa.gov/ttn/amtic/monstratdoc.html">http://www.epa.gov/ttn/amtic/monstratdoc.html</a>	
Siting Criteria	<a href="http://www.epa.gov/ttn/amtic/pretecdoc.html">http://www.epa.gov/ttn/amtic/pretecdoc.html</a>	
Quality System References	<a href="http://www.epa.gov/ttn/amtic/qaqcrein.html">http://www.epa.gov/ttn/amtic/qaqcrein.html</a>	
Data Management References	<a href="http://www.epa.gov/ttn/amtic/pretecdoc.html">http://www.epa.gov/ttn/amtic/pretecdoc.html</a>	

## Photochemical Assessment Monitoring Stations (PAMS)

### Background

Section 182(c)(1) of the 1990 Clean Air Act Amendments (CAAA) require the Administrator to promulgate rules for the enhanced monitoring of ozone, oxides of nitrogen (NO<sub>x</sub>), and volatile organic compounds (VOC) to obtain more comprehensive and representative data on ozone air pollution. Immediately following the promulgation of such rules, the affected states were to commence such actions as were necessary to adopt and implement a program to improve ambient monitoring activities and the monitoring of emissions of NO<sub>x</sub> and VOC. Each State Implementation Plan (SIP) for the affected areas must contain measures to implement the ambient monitoring of such air pollutants. The subsequent revisions to Title 40, Code of Federal Regulations, Part 58 (40 CFR 58) required states to establish Photochemical Assessment Monitoring Stations (PAMS) as part of their SIP monitoring networks in ozone nonattainment areas classified as serious, severe, or extreme.

The chief objective of the enhanced ozone monitoring revisions is to provide an air quality database that will assist air pollution control agencies in evaluating, tracking the progress of, and, if necessary, refining control strategies for attaining the ozone NAAQS. Ambient concentrations of ozone and ozone precursors will be used to make attainment/nonattainment decisions, aid in tracking VOC and NO<sub>x</sub> emission inventory reductions, better characterize the nature and extent of the ozone problem, and prepare air quality trends. In addition, data from the PAMS will provide an improved database for evaluating photochemical model performance, especially for future control strategy mid-course corrections as part of the continuing air quality management process. The data will be particularly useful to states in ensuring the implementation of the most cost-effective regulatory controls.

Reference Category	References	Comments
Program References	<a href="http://www.epa.gov/ttn/amtic/pamsrein.html">http://www.epa.gov/ttn/amtic/pamsrein.html</a> <a href="http://www.epa.gov/air/oaqps/pams/docs.html">http://www.epa.gov/air/oaqps/pams/docs.html</a>	
Pollutants Measured	Ozone, Nitrogen Oxides, VOCs, surface meteorological <a href="http://www.epa.gov/oar/oaqps/pams/general.html#parameters">http://www.epa.gov/oar/oaqps/pams/general.html#parameters</a>	
Methods References		
Network Design References	<a href="http://www.epa.gov/air/oaqps/pams/network.html">http://www.epa.gov/air/oaqps/pams/network.html</a>	
Siting Criteria	<a href="http://www.epa.gov/oar/oaqps/pams/general.html#siting">http://www.epa.gov/oar/oaqps/pams/general.html#siting</a>	
Quality System References		
Data Management References		

## PM<sub>2.5</sub> Chemical Speciation Network

### Background

As part of the effort to monitor particulate matter, EPA monitors and gathers data on the chemical makeup of these particles. EPA established a chemical speciation network consisting of approximately 300 monitoring sites. These sites are placed at various NAMS and SLAMS across the Nation. Fifty-four of these chemical speciation sites, the Speciation Trends Network (STN), will be used to determine, over a period of several years, trends in concentration levels of selected ions, metals, carbon species, and organic compounds in PM<sub>2.5</sub>. Further breakdown on the location or placement of the trends sites requires that approximately 20 of the monitoring sites be placed at existing Photochemical Assessment Monitoring Stations (PAMS). The placement of the remaining trends sites will be coordinated by EPA, the Regional offices, and the monitoring agencies. Locations will be primarily in or near larger Metropolitan Statistical Areas (MSAs). The remaining chemical speciation sites will be used to enhance the required trends network and to provide information for developing effective State Implementation Plans (SIPs).

The STN is a component of the National PM<sub>2.5</sub> Monitoring Network. Although the STN is intended to complement the activities of the much larger gravimetric PM<sub>2.5</sub> measurements network component (whose goal is to establish if NAAQS are being attained), STN data will not be used for attainment or nonattainment decisions. The programmatic objectives of the STN network are:

- annual and seasonal spatial characterization of aerosols;
- air quality trends analysis and tracking the progress of control programs;
- compare the chemical speciation data set to the data collected from the IMPROVE network; and
- development of emission control strategies.

Stakeholders in the STN will be those at EPA seeking to determine concentration trends of PM<sub>2.5</sub> chemical species over a period of 3 or more years and decision-makers at tribal, state and local levels who will use the data as input to models and for development of emission control strategies and determination of their long-term effectiveness. Other users will be public health officials and epidemiological researchers. However, expectations for data sets from the STN must be put in context.

Reference Category	References	Comments
Program References	<a href="http://www.epa.gov/ttn/amtic/speciepg.html">http://www.epa.gov/ttn/amtic/speciepg.html</a>	
Pollutants Measured	ions, metals, carbon species, and organic compounds	
Methods References		
Network Design References		
Siting Criteria		
Quality System References	<a href="http://www.epa.gov/ttn/amtic/specqual.html">http://www.epa.gov/ttn/amtic/specqual.html</a>	
Data Management References	<a href="http://www.epa.gov/ttn/amtic/specdat.html">http://www.epa.gov/ttn/amtic/specdat.html</a>	

## National Toxics Trends Network (NATTS)

### Background

There are currently 188 hazardous air pollutants (HAPs), or Air Toxics (AT), regulated under the Clean Air Act (CAA) that have been associated with a wide variety of adverse health effects, including cancer, neurological, reproductive and developmental effects, as well as eco-system effects. In 1999, EPA finalized the Urban Air Toxics Strategy (UATS). The UATS states that emissions data are needed to quantify the sources of air toxics impacts and aid in the development of control strategies, while ambient monitoring data are needed to understand the behavior of air toxics in the atmosphere after they are emitted. Part of this strategy included the development of the National Air Toxics Trends Stations (NATTS). Specifically, it is anticipated that the NATTS data will be used for:

- tracking trends in ambient levels to facilitate tracking progress toward emission and risk reduction goals, which is the major objective of this program;
- directly evaluating public exposure & environmental impacts in the vicinity of monitors;
- providing quality assured data AT for risk characterization;
- assessing the effectiveness of specific emission reduction activities; and
- evaluating and subsequently improving air toxics emission inventories and model performance.

Currently the NATTS program is made up of 22 monitoring sites; 15 representing urban communities and 7 representing rural communities.

Reference Category	References	Comments
Program References	<a href="http://www.epa.gov/ttn/amtic/natts.html">http://www.epa.gov/ttn/amtic/natts.html</a>	
Pollutants Measured	33 HAPS which include metals, VOCs and carbonyls	
Methods References	<a href="http://www.epa.gov/ttn/amtic/airtox.html">http://www.epa.gov/ttn/amtic/airtox.html</a>	
Network Design References	<a href="http://www.epa.gov/ttn/amtic/airtoxqa.html">http://www.epa.gov/ttn/amtic/airtoxqa.html</a> ,	Reference : National Air Toxics Trends Stations – Quality Management Plan – final 09/09/05
Siting Criteria	<a href="http://www.epa.gov/oar/oaqps/pams/general.html#siting">http://www.epa.gov/oar/oaqps/pams/general.html#siting</a>	Reference : 40 CFR part 58 Appendix E, PAMS Probe and Path Siting Criteria
Quality System References	<a href="http://www.epa.gov/ttn/amtic/airtoxqa.html">http://www.epa.gov/ttn/amtic/airtoxqa.html</a>	
Data Management References	<a href="http://www.epa.gov/ttn/amtic/toxdat.html">http://www.epa.gov/ttn/amtic/toxdat.html</a>	

## Interagency Monitoring of Protected Visual Environments (IMPROVE)

### Background

The Interagency Monitoring of Protected Visual Environments (IMPROVE) program is a cooperative measurement effort governed by a steering committee composed of representatives from federal and regional-state organizations. The IMPROVE monitoring program was established in 1985 to aid the creation of Federal and State Implementation Plans for the protection of visibility in Class I areas ([156 national parks and wilderness areas](#)) as stipulated in the [1977 amendments to the Clean Air Act](#).

The objectives of IMPROVE are:

1. to establish current visibility and aerosol conditions in mandatory class I areas;
2. to identify chemical species and emission sources responsible for existing man-made visibility impairment;
3. to document long-term trends for assessing progress towards the national visibility goal;
4. and with the enactment of the [Regional Haze Rule](#), to provide regional haze monitoring representing all visibility-protected federal class I areas where practical.

IMPROVE has also been a key participant in visibility-related research, including the advancement of monitoring instrumentation, analysis techniques, visibility modeling, policy formulation and source attribution field studies. In addition to 110 IMPROVE sites at visibility-protected areas, IMPROVE Protocol sites are operated identically at locations to serve the needs of state, tribes and federal agencies.

Reference Category	References	Comments
<b>Program References</b>	<a href="http://vista.cira.colostate.edu/improve/">http://vista.cira.colostate.edu/improve/</a> <a href="http://vista.cira.colostate.edu/improve/Overview/IMPROVEProgram_files/frame.htm">http://vista.cira.colostate.edu/improve/Overview/IMPROVEProgram_files/frame.htm</a>	
<b>Pollutants Measured</b>	PM <sub>10</sub> & PM <sub>2.5</sub> mass concentration, and PM <sub>2.5</sub> elements heavier than sodium, anions, organic and elemental carbon concentrations. Optical & met. parameters at select sites	All sites have aerosol speciation monitoring by one day in three 24-hour duration sampling
<b>Methods References</b>	<a href="http://vista.cira.colostate.edu/improve/Publications/IMPROVE_SOPs.htm">http://vista.cira.colostate.edu/improve/Publications/IMPROVE_SOPs.htm</a>	
<b>Network Design References</b>	<a href="http://vista.cira.colostate.edu/improve/Publications/IMPROVE_SOPs.htm">http://vista.cira.colostate.edu/improve/Publications/IMPROVE_SOPs.htm</a>	
<b>Siting Criteria</b>	<a href="http://vista.cira.colostate.edu/improve/Publications/IMPROVE_SOPs.htm">http://vista.cira.colostate.edu/improve/Publications/IMPROVE_SOPs.htm</a>	
<b>Quality System References</b>	<a href="http://vista.cira.colostate.edu/improve/Data/QA_QC/qa_qc_Branch.htm">http://vista.cira.colostate.edu/improve/Data/QA_QC/qa_qc_Branch.htm</a>  <a href="http://www.epa.gov/ttn/amtic/visinfo.html">http://www.epa.gov/ttn/amtic/visinfo.html</a>	
<b>Data Management References</b>	<a href="http://vista.cira.colostate.edu/improve/Data/data.htm">http://vista.cira.colostate.edu/improve/Data/data.htm</a>	



## Clean Air Status and Trends Network (CASTNET)

### Background

EPA, in coordination with the National Oceanic and Atmospheric Administration (NOAA), established CASTNET with the goal of assessing the impact and effectiveness of Title IV of the 1990 Clean Air Act Amendments (CAAA) through a large-scale monitoring network. CASTNET was designed to compile a sound scientific data base through routine environmental monitoring for the evaluation of air-quality management and control strategies. The network provides estimates of dry deposition using an inferential modeling method that relies on atmospheric concentrations, meteorological variables and other input as recorded at each site. The data record extends back to 1987, when routine field measurements first began under National Dry Deposition Network (NDDN). CASTNET currently consists of over 80 sites across the eastern and western United States and is cooperatively operated and funded with the National Park Service. CASTNET complements the National Atmospheric Deposition Program/National Trends Network (NADP/NTN) which provides information on precipitation chemistry and wet deposition values.

The main objective of the network is to:

- 1) track the effectiveness of national and regional scale emission control programs;
- 2) report high quality, publicly available data on the temporal and geographic patterns of air quality and atmospheric deposition trends; and
- 3) provide the necessary information for understanding the environmental effects in sensitive terrestrial and aquatic receptor areas associated with atmospheric loadings of pollutants.

Reference Category	References	Comments
Program References	<a href="http://www.epa.gov/castnet/">http://www.epa.gov/castnet/</a>	
Pollutants Measured	-- weekly average atmospheric concentrations of sulfate, nitrate, ammonium, sulfur dioxide, nitric acid and base cations --hourly concentrations of ambient ozone levels --hourly averages of meteorological variables required for calculating dry deposition rates	
Methods References	CASTNET Quality Assurance Project Plan <a href="http://www.epa.gov/castnet/library.html">http://www.epa.gov/castnet/library.html</a>	
Network Design References	CASTNET Quality Assurance Project Plan <a href="http://www.epa.gov/castnet/library.html">http://www.epa.gov/castnet/library.html</a>	
Siting Criteria	CASTNET Quality Assurance Project Plan <a href="http://www.epa.gov/castnet/library.html">http://www.epa.gov/castnet/library.html</a>	
Quality System References	CASTNET Quality Assurance Project Plan <a href="http://www.epa.gov/castnet/library.html">http://www.epa.gov/castnet/library.html</a>	
Data Management References	<a href="http://www.epa.gov/castnet/library.html">http://www.epa.gov/castnet/library.html</a> <a href="http://cfpub.epa.gov/gdm/index.cfm?fuseaction=aciddeposition.wizard">http://cfpub.epa.gov/gdm/index.cfm?fuseaction=aciddeposition.wizard</a>	

## National Atmospheric Deposition Network (NADP)

### Background

The National Atmospheric Deposition Program (NADP) provides quality-assured data and information in support of research on the exposure of managed and natural ecosystems and cultural resources to acidic compounds, nutrients, base cations, and mercury in precipitation. NADP data serve science and education and support informed decisions on air quality issues related to precipitation chemistry.

The NADP operates three precipitation chemistry networks: the 250-station National Trends Network (NTN), 7-station Atmospheric Integrated Research Monitoring Network (AIRMoN), and 100-station Mercury Deposition Network (MDN). The NTN provides the only long-term nationwide record of the wet deposition of acids, nutrients, and base cations. NTN stations collect one-week precipitation samples in 48 states, Puerto Rico, the Virgin Islands, and Quebec Province, Canada. Complementing the NTN is the 7-station AIRMoN. The daily precipitation samples collected at AIRMoN stations support continued research of atmospheric transport and removal of air pollutants and the development of computer simulations of these processes. The 100-station MDN offers the only regional measurements of mercury in North American precipitation. MDN data are used to quantify mercury deposition to water bodies that have fish and wildlife consumption advisories due to this toxic chemical. Presently, 48 states and 10 Canadian provinces list advisories warning people to limit fish consumption due to high mercury levels. Advisories also were issued for Atlantic Coastal waters from Maine to Rhode Island and North Carolina to Florida, for the entire U.S. Gulf Coast, and for Hawaii.

In addition to these long-term monitoring networks, the NADP is responsive to emerging issues requiring new or expanded measurements. Its measurement system is efficient, its data meet pre-defined data quality objectives, and its reports and products are designed to meet user needs.

Reference Category	References	Comments
<b>Program References</b>	NADP <a href="http://nadp.sws.uiuc.edu/">http://nadp.sws.uiuc.edu/</a> AIRMoN <a href="http://nadp.sws.uiuc.edu/airmon/">http://nadp.sws.uiuc.edu/airmon/</a> MDN <a href="http://nadp.sws.uiuc.edu/mdn/">http://nadp.sws.uiuc.edu/mdn/</a>	
<b>Pollutants Measured</b>	sulfate, nitrate, chloride, ammonium, calcium, magnesium, sodium, potassium, pH, mercury	
<b>Methods References</b>	<a href="http://nadp.sws.uiuc.edu/lib/manuals/opman.pdf">http://nadp.sws.uiuc.edu/lib/manuals/opman.pdf</a> <a href="http://nadp.sws.uiuc.edu/lib/manuals/mdnopman.pdf">http://nadp.sws.uiuc.edu/lib/manuals/mdnopman.pdf</a>	
<b>Network Design References</b>	<a href="http://nadp.sws.uiuc.edu/lib/manuals/siteinst.pdf">http://nadp.sws.uiuc.edu/lib/manuals/siteinst.pdf</a>	
<b>Siting Criteria</b>	<a href="http://nadp.sws.uiuc.edu/lib/manuals/siteinst.pdf">http://nadp.sws.uiuc.edu/lib/manuals/siteinst.pdf</a>	
<b>Quality System References</b>	<a href="http://nadp.sws.uiuc.edu/QA/">http://nadp.sws.uiuc.edu/QA/</a> <a href="http://nadp.sws.uiuc.edu/lib/qaplans/NADP-QMP-Dec2003.pdf">http://nadp.sws.uiuc.edu/lib/qaplans/NADP-QMP-Dec2003.pdf</a> <a href="http://nadp.sws.uiuc.edu/lib/qaplans/qapCal2006.pdf">http://nadp.sws.uiuc.edu/lib/qaplans/qapCal2006.pdf</a>	
<b>Data Management References</b>	<a href="http://nadp.sws.uiuc.edu/airmon/getamdata.asp">http://nadp.sws.uiuc.edu/airmon/getamdata.asp</a>	

## National Air Toxics Assessment (NATA)

### Background

NATA is a national-scale assessment of [33 air pollutants](#) (a subset of 32 air toxics on the Clean Air Act's list of 188, plus [diesel particulate matter](#)). The assessment considers the year 1996 (an update to 1999 is in preparation), including:

- compilation of a national emissions inventory of air toxics emissions from outdoor sources;
- estimates of ambient concentrations across the contiguous United States;
- estimates of population exposures; and
- characterizations of potential public health risks including both cancer and non-cancer effects.

NATA identifies those air toxics which are of greatest potential concern, in terms of contribution to population risk. This information is relevant and useful in assessing risk for tribal programs.

Reference Category	References	Comments
Program References	<a href="http://www.epa.gov/ttn/atw/nata/index.html">http://www.epa.gov/ttn/atw/nata/index.html</a>	
Pollutants Measured	<a href="http://www.epa.gov/ttn/atw/nata/34poll.html">http://www.epa.gov/ttn/atw/nata/34poll.html</a>	33 air pollutants (see link)
Methods References		
Network Design References		
Siting Criteria		
Quality System References		
Data Management References		

## **Appendix B**

### **Ambient Air Monitoring Quality Assurance Information and Web Addresses**

**The following information provides key guidance documents and reports that can be found on various sites within the Ambient Monitoring Technical Information Center (AMTIC) Website. The following identifiers are used to describe national ambient air monitoring programs**

<b>SLAMS-</b>	<b>State or Local Air Monitoring Stations Network</b>
<b>NCORE-</b>	<b>National Core Network</b>
<b>PAMS -</b>	<b>Photochemical Assessment Monitoring Stations</b>
<b>CSN</b>	<b>PM<sub>2.5</sub> Chemical Speciation Network</b>
<b>NATTS-</b>	<b>National Toxics Trends Network</b>
<b>SLAMS-NPAP-</b>	<b>National Performance Audit Program</b>
<b>SLAM-PEP-</b>	<b>National PM<sub>2.5</sub> Performance Evaluation Program</b>

Page intentionally left blank

<b>Ambient Air Quality Assurance Information</b>				
<b>Identifier</b>	<b>Title</b>	<b>EPA Number</b>	<b>Pub Date Year</b>	<b>URL</b>
<b>GUIDANCE DOCUMENTS</b>				
CSN	Particulate Matter (PM2.5) Speciation Guidance Document		1999	<a href="http://www.epa.gov/ttn/amtic/files/ambient/pm25/spec/specinl.pdf">http://www.epa.gov/ttn/amtic/files/ambient/pm25/spec/specinl.pdf</a>
NATTS	NATTS Technical Assistance Document (TAD)		2007	<a href="http://www.epa.gov/ttn/amtic/airtox.html">http://www.epa.gov/ttn/amtic/airtox.html</a>
NCore	NCore Technical Assistance Document (TAD)			<a href="http://www.epa.gov/ttn/amtic/files/ambient/monitorstrat/precursor/tad_version4.pdf">http://www.epa.gov/ttn/amtic/files/ambient/monitorstrat/precursor/tad_version4.pdf</a>
NCore	QA Handbook for Air Pollution Measurement Systems Volume IV Meteorological Measurement Systems	EPA-454/B-08-002	2008	<a href="http://www.epa.gov/ttn/amtic/met.html">http://www.epa.gov/ttn/amtic/met.html</a>
PAMS	Technical Assistance Document (TAD) for Sampling and Analysis of Ozone Precursors;	EPA/600-R-98/161	1998	<a href="http://www.epa.gov/ttn/amtic/files/ambient/pams/newtad.pdf">http://www.epa.gov/ttn/amtic/files/ambient/pams/newtad.pdf</a>
SLAMS	QA Handbook for Air Pollution Measurement Systems Volume II	EPA-454/R-98-004	1998	<a href="http://www.epa.gov/ttn/amtic/files/ambient/qaqc/redbook.pdf">http://www.epa.gov/ttn/amtic/files/ambient/qaqc/redbook.pdf</a>
SLAMS	Guideline on the Meaning and the Use of Precision and Bias Data Required by 40 CFR Part 58 Appendix A	EPA-545/B-07-001	2007	<a href="http://www.epa.gov/ttn/amtic/files/ambient/qaqc/P&amp;B%20Guidance%2010.10.07%20vers1.1.pdf">http://www.epa.gov/ttn/amtic/files/ambient/qaqc/P&amp;B%20Guidance%2010.10.07%20vers1.1.pdf</a>
SLAMS	Transfer Standards for the Calibration of Air Monitoring Analyzers for Ozone	EPA-600/4-79-056	1979	<a href="http://www.epa.gov/ttn/amtic/files/ambient/criteria/reldocs/4-79-056.pdf">http://www.epa.gov/ttn/amtic/files/ambient/criteria/reldocs/4-79-056.pdf</a>
SLAMS	Technical Assistance Document for the Calibration of Ozone Monitors	EPA-600/4-79-057	1979	<a href="http://www.epa.gov/ttn/amtic/files/ambient/criteria/reldocs/4-79-057.pdf">http://www.epa.gov/ttn/amtic/files/ambient/criteria/reldocs/4-79-057.pdf</a>
SLAMS PM2.5	PM <sub>2.5</sub> Quality Assurance Program Overview		1997	<a href="http://www.epa.gov/ttn/amtic/files/ambient/pm25/qa/pm25qa.pdf">http://www.epa.gov/ttn/amtic/files/ambient/pm25/qa/pm25qa.pdf</a>
<b>QA REPORTS</b>				
CSN	PM 2.5 Speciation Lab Audit Reports and Assessments		Various Years	<a href="http://www.epa.gov/ttn/amtic/pmspec.html">http://www.epa.gov/ttn/amtic/pmspec.html</a>
NATTS	National Air Toxics Trends Stations Quality Assurance Annual Reports and Proficiency Reports		Various Years	<a href="http://www.epa.gov/ttn/amtic/airtoxqa.html">http://www.epa.gov/ttn/amtic/airtoxqa.html</a>
SLAMS	2007 Quality Management Plan and Quality Assurance Project Plan Tracking Matrix as of June 25, 2007		2007	<a href="http://www.epa.gov/ttn/amtic/files/ambient/qaqc/Region%20Matrix%2006.25.07.pdf">http://www.epa.gov/ttn/amtic/files/ambient/qaqc/Region%20Matrix%2006.25.07.pdf</a>
SLAMS	Annual Precision, Bias and Completeness Reports for Criteria Pollutants		Various Years	<a href="http://www.epa.gov/ttn/amtic/parslist.html">http://www.epa.gov/ttn/amtic/parslist.html</a>
SLAMS-PM2.5	3-Year and Annual QA Reports		Various Years	<a href="http://www.epa.gov/ttn/amtic/anlqa.html">http://www.epa.gov/ttn/amtic/anlqa.html</a>
SLAMS-PEP	Laboratory Comparison Study of Gravimetric Laboratories Performing PM <sub>2.5</sub> Filter Weighing for the PM <sub>2.5</sub> Performance Evaluation Program and Tribal Air Monitoring Support		Various Years	<a href="http://www.epa.gov/ttn/amtic/pmpep.html">http://www.epa.gov/ttn/amtic/pmpep.html</a>
<b>Methods</b>				
CSN	Speciation Field Guidance Documents		Various Years	<a href="http://www.epa.gov/ttn/amtic/specquid.html">http://www.epa.gov/ttn/amtic/specquid.html</a>
NATTS	Air Toxics Methods- Various Methods		2007	<a href="http://www.epa.gov/ttn/amtic/airtox.html">http://www.epa.gov/ttn/amtic/airtox.html</a>
NCore	Calibration of Meteorological Measurement -Videos		2008	<a href="http://www.epa.gov/ttn/amtic/met.html">http://www.epa.gov/ttn/amtic/met.html</a>
SLAMS	QA Handbook Vol II (DRAFT Procedure for the "Determination of Ozone By Ultraviolet Analysis")		1998	<a href="http://www.epa.gov/ttn/amtic/files/ambient/qaqc/ozone4.pdf">http://www.epa.gov/ttn/amtic/files/ambient/qaqc/ozone4.pdf</a>
SLAMS	Sec. 2.10 of QA Handbook - Draft - PM10- Dichot revised to local standard and pressure	EPA-600/4-77-027a	1997	<a href="http://www.epa.gov/ttn/amtic/files/ambient/qaqc/2-10meth.pdf">http://www.epa.gov/ttn/amtic/files/ambient/qaqc/2-10meth.pdf</a>
SLAMS	Sec. 2.11 of QA Handbook - Draft - PM10 Hi Vol revised to local standard and pressure		1997	<a href="http://www.epa.gov/ttn/amtic/files/ambient/qaqc/2-11meth.pdf">http://www.epa.gov/ttn/amtic/files/ambient/qaqc/2-11meth.pdf</a>
SLAMS	Section 2.3 -- DRAFT - Reference Method for the Determination of Nitrogen Dioxide in the Atmosphere (Chemiluminescence)		2002	<a href="http://www.epa.gov/ttn/amtic/files/ambient/pm25/qa/no2.pdf">http://www.epa.gov/ttn/amtic/files/ambient/pm25/qa/no2.pdf</a>
SLAMS-NPAP	DRAFT SOP for Through-the-Probe Performance Evaluations of Ambient Air Quality Monitoring of Criteria Air Pollutants		2007	<a href="http://www.epa.gov/ttn/amtic/files/ambient/npapsop/npaptpsop.pdf">http://www.epa.gov/ttn/amtic/files/ambient/npapsop/npaptpsop.pdf</a>

<b>Ambient Air Quality Assurance Information</b>				
<b>Identifier</b>	<b>Title</b>	<b>EPA Number</b>	<b>Pub Date Year</b>	<b>URL</b>
SLAMS-NPAP	Quality Assurance Project Plan for the Audit Support Program - NPAP and NATTS		2006	<a href="http://www.epa.gov/ttn/amtic/files/ambient/qaqc/NPAPQAPPrvsn071007onforTTP.pdf">http://www.epa.gov/ttn/amtic/files/ambient/qaqc/NPAPQAPPrvsn071007onforTTP.pdf</a>
SLAMS-PEP	Method Compendium "Field Standard Operating Procedures for the PM <sub>2.5</sub> Performance Evaluation Program"		2006	<a href="http://www.epa.gov/ttn/amtic/files/ambient/pm25/qa/pepfield.pdf">http://www.epa.gov/ttn/amtic/files/ambient/pm25/qa/pepfield.pdf</a>
SLAMS-PEP	Method Compendium "PM <sub>2.5</sub> Mass Weighing Laboratory Standard Operating Procedures for the Performance Evaluation Program"		1998	<a href="http://www.epa.gov/ttn/amtic/files/ambient/pm25/qa/peplsop.pdf">http://www.epa.gov/ttn/amtic/files/ambient/pm25/qa/peplsop.pdf</a>
SLAMS-PM2.5	2.12 "Monitoring PM <sub>2.5</sub> in Ambient Air Using Designated Reference or Class I Equivalent Methods"		1998	<a href="http://www.epa.gov/ttn/amtic/files/ambient/pm25/qa/m212covd.pdf">http://www.epa.gov/ttn/amtic/files/ambient/pm25/qa/m212covd.pdf</a>
<b>IMPLEMENTATION PLANS and QAPPs</b>				
CSN	Speciation Laboratory Standard Operating Procedures		Various Years	<a href="http://www.epa.gov/ttn/amtic/specsop.html">http://www.epa.gov/ttn/amtic/specsop.html</a>
CSN	Quality Management Plan for the PM <sub>2.5</sub> Speciation Trends Network	EPA-454/R-01-009	2001	<a href="http://www.epa.gov/ttn/amtic/files/ambient/pm25/spec/finlqmp.pdf">http://www.epa.gov/ttn/amtic/files/ambient/pm25/spec/finlqmp.pdf</a>
CSN	"Speciation Trends Network Quality Assurance Project Plan"	EPA-454/R-01-001	2001	<a href="http://www.epa.gov/ttn/amtic/files/ambient/pm25/spec/1025sqap.pdf">http://www.epa.gov/ttn/amtic/files/ambient/pm25/spec/1025sqap.pdf</a>
NATTS	Model Quality Assurance Project Plan for the National Air Toxics Trends Stations - updated version 1.1		2007	<a href="http://www.epa.gov/ttn/amtic/files/ambient/airtox/NATTS_Model_QA_PP.pdf">http://www.epa.gov/ttn/amtic/files/ambient/airtox/NATTS_Model_QA_PP.pdf</a>
NATTS	Model QAPP for Local-Scale Monitoring Projects"	EPA-454/R-01-007	2006	<a href="http://www.epa.gov/ttn/amtic/files/ambient/airtox/pilotqapp.pdf">http://www.epa.gov/ttn/amtic/files/ambient/airtox/pilotqapp.pdf</a>
NATTS	National Air Toxics Trends Stations - Quality Management Plan Final		2005	<a href="http://www.epa.gov/ttn/amtic/files/ambient/airtox/nattsqmp.pdf">http://www.epa.gov/ttn/amtic/files/ambient/airtox/nattsqmp.pdf</a>
PAMS	PAMS Implementation Manual	EPA-454/B-93-051	1994	<a href="http://www.epa.gov/ttn/amtic/files/ambient/pams/b93-051a.pdf">http://www.epa.gov/ttn/amtic/files/ambient/pams/b93-051a.pdf</a>
SLAMS	Quality Assurance Project Plan for the Audit Support Program - NPAP and NATTS		2008	<a href="http://www.epa.gov/ttn/amtic/files/ambient/qaqc/NPAPQAPPrvsn071007onforTTP.pdf">http://www.epa.gov/ttn/amtic/files/ambient/qaqc/NPAPQAPPrvsn071007onforTTP.pdf</a>
SLAMS PM2.5	PM <sub>2.5</sub> Model QA Project Plan (QAPP)"	EPA-454/R-98-005	1998	<a href="http://www.epa.gov/ttn/amtic/files/ambient/pm25/qa/totdoc.pdf">http://www.epa.gov/ttn/amtic/files/ambient/pm25/qa/totdoc.pdf</a>
SLAMS PM2.5	PM2.5 FRM Network Federal Performance Evaluation Program Quality Assurance Project Plan (QAPP)		2007	<a href="http://www.epa.gov/ttn/amtic/files/ambient/pm25/qa/pepqapp_DRAFT_12-2007_cmt_vrsn.pdf">http://www.epa.gov/ttn/amtic/files/ambient/pm25/qa/pepqapp_DRAFT_12-2007_cmt_vrsn.pdf</a>
SLAMS PM2.5	PM <sub>2.5</sub> Performance Evaluation Program Implementaion Plan		1998	<a href="http://www.epa.gov/ttn/amtic/files/ambient/pm25/qa/pep-ip.pdf">http://www.epa.gov/ttn/amtic/files/ambient/pm25/qa/pep-ip.pdf</a>
<b>WHITE PAPERS/IMPORTANT MEMOS</b>				
CSN	Current List of CSN Sites as of 07-11-2007		2007	<a href="http://www.epa.gov/ttn/amtic/specgen.html">http://www.epa.gov/ttn/amtic/specgen.html</a>
CSN	Modification of Carbon Procedures in the Speciation Network; Overview and Frequently Asked Questions		2006	<a href="http://www.epa.gov/ttn/amtic/files/ambient/pm25/spec/faqcarbon.pdf">http://www.epa.gov/ttn/amtic/files/ambient/pm25/spec/faqcarbon.pdf</a>
SLAMS	QA National Meeting Presentations		Various Years	<a href="http://www.epa.gov/ttn/amtic/qamsmtg.html">http://www.epa.gov/ttn/amtic/qamsmtg.html</a>
SLAMS	QA Newsletters		Various Years	<a href="http://www.epa.gov/ttn/amtic/qanews.html">http://www.epa.gov/ttn/amtic/qanews.html</a>

## **Appendix C**

### **Using the Graded Approach for the Development of QMPs and QAPPs in Ambient Air Quality Monitoring Programs**



*This page intentionally left blank*

## **Using the Graded Approach for the Development of QMPs and QAPPs in Ambient Air Quality Monitoring Programs**

EPA policy requires that all organizations funded by EPA for environmental data operations (EDOs) develop quality management plans (QMPs) and quality assurance project plans (QAPPs). In addition, EPA has provided flexibility to EPA organizations on how they implement this policy, allowing for use of a graded approach. The following proposal explains the graded approach for data collection activities related to ambient air monitoring. OAQPS proposes a graded approach for the development of QAPPs and QMPs.

### **The Graded Approach**

The QMP describes the quality system in terms of the organizational structure, functional responsibilities of management and staff, lines of authority, and required interfaces for those planning, implementing, and assessing activities involving EDOs. Each program should provide appropriate documentation of their quality system. Here are a few ways that this could be handled.

Concept - Small organizations may have limited ability to develop and implement a quality system. EPA should provide options for those who are capable of making progress towards developing a quality system. If it is clear that the EDO goals are understood and that progress in quality system development is being made, a non-optimal quality system structure, for the interim, is acceptable. The concept is to work with the small organization to view the QMP as a long-term strategic plan with an open ended approach to quality system development that will involve continuous improvement. The graded approach to QMP development is described below and is based on the size of the organization and experience in working with EPA and the associated QA requirements.

1. Small organization that just received its first EPA grant or using a grant for a discrete, small, project-level EDO. Such organizations could incorporate a description of its quality system into its QAPP.
2. Small organization implementing EDOs with EPA at more frequent intervals or implementing long-term monitoring programs with EPA funds. If such an organization demonstrates capability of developing and implementing a stand-alone quality system, it is suggested that an appropriate separate QMP be written.
3. Medium or large organization. Develop QMP to describe its quality system and QAPPs for specific EDOs. Approval of the recipient's QMP by the EPA Project Officer and the EPA Quality Assurance Manager may allow delegation of the authority to review and approve Quality Assurance Project Plans (QAPPs) to the grant recipient based on acceptable procedures documented in the QMP.

## **Quality Assurance Project Plans**

The QAPP is a formal document describing, in comprehensive detail, the necessary QA/QC and other technical activities that must be implemented to ensure that the results of work performed will satisfy the stated performance criteria, which may be in the form of a data quality objective (DQO). The quality assurance policy of the EPA requires every EDO to have written and approved quality assurance project plans (QAPPs) prior to the start of the EDO. It is the responsibility of the EPA Project Officer (person responsible for the technical work on the project) to adhere to this policy. If the Project Officer gives permission to proceed without an approved QAPP, he/she assumes all responsibility. If a grantee's QMP is approved by EPA and provides for delegation of QAPP approval to the grantee, the grantee is responsible to ensuring approval of the QAPP prior to the start of the EDO.

The Ambient Air Monitoring Program recommends a four-tiered project category approach to the Ambient Air QA Program in order to effectively focus QA. Category I involves the most stringent QA approach, utilizing all QAPP elements as described in EPA R5<sup>a</sup> (see Table 2), whereas category IV is the least stringent, utilizing fewer elements. In addition, the amount of detail or specificity required for each element will be less as one moves from category I to IV. Table 1 provides information that helps to define the categories of QAPPs based upon the data collection objective. Each type of ambient air monitoring program EDO will be associated with one of these categories. The comment area of the table will identify whether QMPs and QAPPs can be combined and the type of data quality objectives (DQOs) required (see below). Table 2 identifies which of the 24 QAPP elements are required for each category of QAPP. Based upon a specific project, the QAPP approving authority may add/delete elements for a particular category as it relates to the project but in general, this table will be applicable based on the category of QAPP.

### **Flexibility on the systematic planning process and DQO development**

Table 1 describes 4 QAPP/QMP categories which require some type of statement about the program or project objectives. Three of the categories use the term data quality objectives (DQOs), but there should be flexibility with the systematic planning process on how these DQOs are developed based on the particular category. For example, a category 1 project would have formal DQOs. Examples of category I projects, such as the State and Local Monitoring Stations (SLAMS), have DQOs developed by OAQPS. Category II QAPPS may have formal DQOs developed if there are national implications to the data (i.e., Speciation Trends Network) or less formal DQOs if developed by organizations implementing important projects that are more local in scope. Categories 3 and 4 would require less formal DQOs to a point that only project goals (category 4) may be necessary.

---

<sup>a</sup> EPA Requirements for QA Project Plans (QA/R-5) [http://www.epa.gov/quality/qa\\_docs.html](http://www.epa.gov/quality/qa_docs.html)

### **Standard Operating Procedures- (SOP)**

SOPs are an integral part of the QAPP development and approval process and usually address key information required by the QAPP elements. Therefore, SOPs can be referenced in QAPP elements as long as the SOPs are available for review or are part of the QAPP.

**Table 1. Ambient Air Monitoring Program QAPP/QMP categories**

Categories	Programs	QAPP/QMP Comments	DQO
<p><b>Category 1</b>                      Projects include EDOs that directly support rulemaking, enforcement, regulatory, or policy decisions. They also include research projects of significant national interest, such as those typically monitored by the Administrator. Category I projects require the most detailed and rigorous QA and QC for legal and scientific defensibility. Category I projects are typically stand-alone; that is, the results from such projects are sufficient to make the needed decision without input from other projects.</p>	SLAMS PSD NCore IMPROVE CastNet	Most agencies implementing Ambient Air Monitoring Networks will have separate QMPs and QAPPs. However, a Region has the discretion to approve QMP/QAPP combination for small monitoring organizations (i.e., Tribes)	Formal DQOs
<p><b>Category 2</b>                      Projects include EDOs that complement other projects in support of rulemaking, regulatory, or policy decisions. Such projects are of sufficient scope and substance that their results could be combined with those from other projects of similar scope to provide necessary information for decisions. Category II projects may also include certain high visibility projects as defined by EPA management</p>	Speciation Trends Toxics Mon.	Most agencies implementing Ambient Air Monitoring Networks will have separate QMPs and QAPPs. However, a Region has the discretion to approve QMP/QAPP combination for small monitoring organizations (i.e., Tribes)	Formal DQOs for national objective, Flexible DQOs for localized objectives
<p><b>Category 3</b>                      Projects include EDOs performed as interim steps in a larger group of operations. Such projects include those producing results that are used to evaluate and select options for interim decisions or to perform feasibility studies or preliminary assessments of unexplored areas for possible future work.</p>	SPM One time Studies Local Scale Air Toxics Grants	EDOs of short duration. QMP and QAPP can be combined.	Flexible DQOs
<p><b>Category 4</b>                      Projects involving EDOs to study basic phenomena or issues, including proof of concepts, screening for particular analytical species, etc. Such projects generally do not require extensive detailed QA/QC activities and documentation</p>	Education/Outreach		Project Objectives or Goals

**Table 2 QAPP Elements**

QAPP Element	Category Applicability
A1 Title and Approval Sheet	I, II, III, IV
A2 Table of Contents	I, II, III
A3 Distribution List	I,
A4 Project/Task Organization	I, II, III
A5 Problem Definition/Background	I, II, III
A6 Project/Task Description	I, II, III, IV
A7 Quality Objectives and Criteria for Measurement Data	I, II, III, IV
A8 Special Training Requirements/Certification	I
A9 Documentation and Records	I, II, III
B1 Sample Process (Network) Design	I, II, III, IV
B2 Sampling Methods Requirements	I, II, III,
B3 Sample Handling and Custody Requirements	I, II, III
B4 Analytical Methods Requirements	I, II, III, IV
B5 Quality Control Requirements	I, II, III, IV
B6 Instrument/Equipment Testing, Inspection & Maintenance	I, II, III
B7 Instrument Calibration and Frequency	I, II, III
B8 Inspection/Acceptance Requirements for Supplies and Con.	I,
B9 Data Acquisition Requirements for Non-direct Measurements	I, II, III
B10 Data Management	I, II
C1 Assessments and Response Actions	I, II,
C2 Reports to Management	I, II,
D1 Data Review, Validation, and Verification Requirements	I, II, III
D2 Validation and Verification Methods	I, II
D3 Reconciliation and User Requirements	I, II,

## Appendix D

### Measurement Quality Objectives and Validation Templates

In June 1998, a workgroup was formed to develop a procedure that could be used by State and locals that would provide for a consistent validation of PM<sub>2.5</sub> mass concentrations across the US. The workgroup included personnel from the monitoring organizations, EPA Regional Offices, and OAQPS who are involved with assuring the quality of PM<sub>2.5</sub> mass and was headed by a State and local representative. The workgroup developed three tables of criteria where each table has a different degree of implication about the quality of the data. The criteria included on the tables are from 40 CFR Part 50 Appendices L and N, 40 CFR Part 58 Appendix A, Method 2.12, and a few criteria that are neither in CFR nor Method 2.12. Upon completion and use of the table, it was decided that a “validation template” should be developed for all the criteria pollutants.

One of the tables has the criteria that *must* be met to ensure the quality of the data. An example criterion is that the average flow rate for the sampling period must be maintained to within 5% of 16.67 liters per minute. The second table has the criteria that indicate that there *might* be a problem with the quality of the data and further investigation is warranted before making a determination about the validity of the sample or samples. An example criterion is that the field filter blanks should not change weight by more than 30 µg between weighings. The third table has criteria that indicate a potentially systematic problem with the environmental data collection activity. Such systematic problems may impact the ability to make decisions with the data. An example criterion is that at least 75% of the scheduled samples for each quarter should be successfully collected and validated.

To determine the appropriate table for each criterion, the members of the workgroup considered how significantly the criterion impact the resulting concentration. This was based on experience from workgroup members, experience from non-workgroup members, and feasibility of implementing the criterion.

Criteria that were deemed critical to maintaining the integrity of a sample or group of samples were placed on the first table. Observations that do not meet each and every criterion on the **Critical Criteria Table** should be invalidated unless there are compelling reason and justification for not doing so. Basically, the sample or group of samples for which one or more of these criteria are not met is invalid until proven otherwise. The cause of not operating in the acceptable range for each of the violated criteria must be investigated and minimized to reduce the likelihood that additional samples will be invalidated.

Criteria that are important for maintaining and evaluating the quality of the data collection system are included on the second table, the **Operational Evaluations Table**. Violation of a criterion or a number of criteria may be cause for invalidation. The decision should consider other quality control information that may or may not indicate the data are acceptable for the parameter being controlled. Therefore, the sample or group of samples for which one or more of these criteria are not met is suspect unless other quality control information demonstrates otherwise. The reason for not meeting the criteria **MUST** be investigated, mitigated or justified.

Finally, those criteria which are important for the correct interpretation of the data but do not usually impact the validity of a sample or group of samples are included on the third table, the **Systematic Issues Table**. For example, the data quality objectives are included in this table. If the data quality objectives are not met, this does not invalidate any of the samples but it may impact the error rate associated with the attainment/non-attainment decision.

Following are the tables. For each criterion, the tables include (1) the operational range that is acceptable, (2) the frequency with which compliance is to be evaluated, (3) the number of samples that are impacted if violation of a criterion occurs (possible values include single filters, a batch of filters, or a group of filters from a specific instrument);(4) sections of 40 CFR and (5) Method 2.12 that describe the criterion. The table also indicates whether samples violating the criterion must be flagged before entering them into AQS.

This validation template has been developed based on the current state of knowledge. The template should evolve as new information is discovered about the impact of the various criterion on the error in the resulting mass estimate. Interactions of the criteria, whether synergistic or antagonistic, should also be incorporated when the impact of these interactions becomes quantified. Due to the potential misuse of invalid data, data that are invalidated will not be uploaded to AQS but should be retained on the monitoring organizations local database. This data will be invaluable to the evolution of the validation template.

### **PM<sub>10</sub> Note of Caution**

The validation templates for PM<sub>10</sub> get complicated because PM<sub>10</sub> is required to be reported at standard temperature and pressure (STP) for comparison to the NAAQS (and follow 40 CFR Part 50 App J) and at local conditions if using it to monitor for PM<sub>10-2.5</sub> (and follow 40 CFR Part 50 App O) in addition PM<sub>10</sub> is measured with filter based sampling techniques as well as with automated methods. The validation templates developed for PM<sub>10</sub> try to accommodate these differences but monitoring organizations are cautioned to review the operations manual for the monitors/samplers they use and augment the validation template with QC information specific to their method.



### Ozone Validation Template

Requirement	Frequency	Acceptance Criteria	Information /Action
<b>CRITICAL CRITERIA-Ozone</b>			
<b>One Point QC Check Single analyzer</b>	1/ 2 weeks	$\leq \pm 7\%$ (percent difference)	0.01 - 0.10 ppm Relative to routine concentrations 40 CFR Part 58 App A Sec 3.2
<b>Zero/span check</b>	1/ 2 weeks	Zero drift $\leq \pm 2\%$ of full scale Span drift $\leq \pm 7\%$	
<b>OPERATIONAL CRITERIA - Ozone</b>			
<b>Shelter Temperature</b>			
Temperature range	<b>Daily</b> (hourly values)	20 to 30° C. (Hourly ave) or per manufacturers specifications if designated to a wider temperature range	Generally the 20-30 ° C range will apply but the most restrictive operable range of the instruments in the shelter may also be used as guidance
Temperature Control	Daily (hourly values)	$\leq \pm 2^\circ \text{C SD}$ over 24 hours	
Temperature Device Check	2/year	$\pm 2^\circ \text{C}$ of standard	
<b>Precision(using 1-point QC checks)</b>	Calculated annually and as appropriate for design value estimates	90% CL CV $\leq 7\%$	90% Confidence Limit of coefficient of variation. 40 CFR Part 58 App A sec 4.1.2
<b>Bias (using 1-point QC checks)</b>	Calculated annually and as appropriate for design value estimates	95% CL $\leq \pm 7\%$	95% Confidence Limit of absolute bias estimate. 40 CFR Part 58 App A sec 4.1.3
<b>Annual Performance Evaluation</b>			
Single analyzer	Every site 1/year 25 % of sites quarterly	Percent difference of each audit level $\leq 15\%$	3 consecutive audit concentration not including zero. 40 CFR Part 58 App A sec 3.2.2
Primary QA Organization (PQAO)	annually	95% of audit percent differences fall within the one point QC check 95% probability intervals at PQAO level of aggregation	40 CFR Part 58 App A sec 4.1.4
<b>Federal Audits (NPAP)</b>	1/year at selected sites 20% of sites audited	Mean absolute difference $\leq 10\%$	40 CFR Part 58 App A sec 2.4
<b>State audits</b>	1/year	State requirements	
<b>Verification/Calibration</b>	Upon receipt/adjustment/repair/ installation/moving 1/6 months if manual zero/span performed biweekly 1/year if continuous zero/span performed daily	All points within $\pm 2\%$ of full scale of best-fit straight line Linearity error $<5\%$	Multi-point calibration (0 and 4 upscale points) 40 CFR Part 50 App D sec 5.2.3
<b>Zero Air</b>		Concentrations below LDL	
<b>Gaseous Standards</b>		NIST Traceable (e.g., EPA Protocol Gas)	40 CFR Part 58 App A sec 2.6.1
<b>Zero Air Check</b>	1/year	Concentrations below LDL	

Requirement	Frequency	Acceptance Criteria	Information /Action
<b>Ozone Local primary standard</b>			
Certification/recertification to Standard Reference Photometer	1/year	single point difference $\leq \pm 3\%$	Primary Standards usually transported to EPA Regions SRP for comparison
(if recertified via a transfer standard)	1/year	Regression slopes = $1.00 \pm 0.03$ and two intercepts are $0 \pm 3$ ppb	
<b>Ozone Transfer standard</b>			
Qualification	Upon receipt of transfer standard	$\pm 4\%$ or $\pm 4$ ppb (whichever greater)	Transfer Standard Doc EPA 600/4-79-056 Section 6.4
Certification	After qualification and upon receipt/adjustment/repair	RSD of six slopes $\leq 3.7\%$ Std. Dev. of 6 intercepts 1.5	Transfer Standard Doc EPA 600/4-79-056 Section 6.6
Recertification to local primary standard	Beginning and end of O3 season or 1/6 months whichever less	New slope = $\pm 0.05$ of previous and RSD of six slopes $\leq 3.7\%$ Std. Dev. of 6 intercepts 1.5	1 recertification test that then gets added to most recent 5 tests. If does not meet acceptability certification fails
Lower detectable level	1/year	0.003 ppm	
<b>SYSTEMATIC CRITERIA- Ozone</b>			
Requirement	Frequency	Acceptance Criteria	Information /Action
<b>Standard Reporting Units</b>	All data	ppm (final units in AQS)	
<b>Completeness</b> (seasonal)	Daily	75% of hourly averages for the 8-hour period	8-Hour Average
<b>Sample Residence Times</b>		< 20 seconds	
<b>Sample Probe, Inlet, Sampling train</b>		Borosilicate glass (e.g., Pyrex®) or Teflon®	40 CFR Part 58 App E
<b>Siting</b>		Un-obstructed probe inlet	40 CFR Part 58 App E
<b>EPA Standard Ozone Reference Photometer (SRP) Recertification</b>	1/year	Regression slope = $1.00 \pm 0.01$ and intercept < 3 ppb	This is usually at a Regional Office and is compared against the traveling SRP

**CO Validation Template**

Requirement	Frequency	Acceptance Criteria	Information /Action
<b>CRITICAL CRITERIA-CO</b>			
<b>One Point QC Check Single analyzer</b>	1/ 2 weeks	$\leq \pm 10\%$ (percent difference)	1 - 10 ppm Relative to routine concentrations 40 CFR Part 58 App A Sec 3.2
<b>Zero/span check</b>	1/ 2 weeks	Zero drift $\leq \pm 2\%$ of full scale Span drift $\leq \pm 10\%$	
<b>OPERATIONAL CRITERIA-CO</b>			
<b>Shelter Temperature</b>			
Temperature range	<b>Daily</b> (hourly values)	20 to 30° C. (Hourly ave) or per manufacturers specifications if designated to a wider temperature range	Generally the 20-30 ° C range will apply but the most restrictive operable range of the instruments in the shelter may also be used as guidance
Temperature Control	Daily (hourly values)	$\leq \pm 2^{\circ}$ C SD over 24 hours	
Temperature Device Check	2/year	$\pm 2^{\circ}$ C of standard	
<b>Precision(using 1-point QC checks)</b>	Calculated annually and as appropriate for design value estimates	90% CL CV $\leq 10\%$	90% Confidence Limit of coefficient of variation. 40 CFR Part 58 App A sec 4.1.2
<b>Bias (using 1-point QC checks)</b>	Calculated annually and as appropriate for design value estimates	95% CL $\leq \pm 10\%$	95% Confidence Limit of absolute bias estimate 40 CFR Part 58 App A sec 4.1.3
<b>Annual Performance Evaluation</b>			
Single analyzer	Every site 1/year 25 % of sites quarterly	Percent difference of each audit level $\leq 15\%$	3 consecutive audit concentration not including zero. 40 CFR Part 58 App A sec 3.2.2
Primary QA Organization (PQAO)	annually	95% of audit percent differences fall within the one point QC check 95% probability intervals at PQAO level of aggregation	40 CFR Part 58 App A sec 4.1.4
<b>Federal Audits (NPAP)</b>	1/year at selected sites 20% of sites audited	Mean absolute difference $\leq 15\%$	40 CFR Part 58 App A sec 2.4
<b>State audits</b>	1/year	State requirements	
<b>Verification/Calibration</b>	Upon receipt/adjustment/repair/ installation/moving 1/6 months if manual zero/span performed biweekly 1/year if continuous zero/span performed daily	All points within $\pm 2\%$ of full scale of best-fit straight line	Multi-point calibration (0 and 4 upscale points)
<b>Gaseous Standards</b>		NIST Traceable (e.g., EPA Protocol Gas)	Vendor must participate in EPA Protocol Gas Verification Program 40 CFR Part 58 App A sec 2.6.1
<b>Zero Air/Zero Air Check</b>	1/year	Concentrations below LDL	

<b>Requirement</b>	<b>Frequency</b>	<b>Acceptance Criteria</b>	<b>Information /Action</b>
<b>Gas Dilution Systems</b>	1/3 months	Accuracy $\pm$ 2 %	
<b>Detection</b>			
Noise	NA	0.50 ppm	40 CFR Part 53.20
Lower detectable level	1/year	1.0 ppm	40 CFR Part 53.20
<b>SYSTEMATIC CRITERIA-CO</b>			
<b>Standard Reporting Units</b>	All data	ppm (final units in AQS)	
<b>Completeness</b> (seasonal)	Hourly	75% of hourly averages for the 8-hour period	8-Hour average
<b>Sample Residence Times</b>		< 20 seconds	
<b>Sample Probe, Inlet, Sampling train</b>		Borosilicate glass (e.g., Pyrex <sup>®</sup> ) or Teflon <sup>®</sup>	40 CFR Part 58 App E
<b>Siting</b>		Un-obstructed probe inlet	40 CFR Part 58 App E

## NO<sub>2</sub> Validation Template

Requirement	Frequency	Acceptance Criteria	Information /Action
<b>CRITICAL CRITERIA- NO<sub>2</sub></b>			
<b>One Point QC Check Single analyzer</b>	1/ 2 weeks	$\leq \pm 10\%$ (percent difference)	0.01 - 0.10 ppm Relative to routine concentrations 40 CFR Part 58 App A Sec 3.2
<b>Zero/span check</b>	1/ 2 weeks	Zero drift $\leq \pm 3\%$ of full scale Span drift $\leq \pm 10\%$	
<b>OPERATIONAL CRITERIA- NO<sub>2</sub></b>			
<b>Shelter Temperature</b>			
Temperature range	<b>Daily</b> (hourly values)	20 to 30° C. (Hourly ave) or per manufacturers specifications if designated to a wider temperature range	Generally the 20-30 ° C range will apply but the most restrictive operable range of the instruments in the shelter may also be used as guidance
Temperature Control	Daily (hourly values)	$\leq \pm 2^\circ \text{C}$ SD over 24 hours	
Temperature Device Check	2/year	$\pm 2^\circ \text{C}$ of standard	
<b>Precision (using 1-point QC checks)</b>	Calculated annually and as appropriate for design value estimates	90% CL CV $\leq 10\%$	90% Confidence Limit of coefficient of variation. 40 CFR Part 58 App A sec 4.1.2
<b>Bias (using 1-point QC checks)</b>	Calculated annually and as appropriate for design value estimates	95% CL $\leq \pm 10\%$	95% Confidence Limit of absolute bias estimate. 40 CFR Part 58 App A sec 4.1.3
<b>Annual Performance Evaluation</b>			
Single analyzer	Every site 1/year 25 % of sites quarterly	Percent difference of each audit level $\leq 15\%$	3 consecutive audit concentration not including zero. 40 CFR Part 58 App A sec 3.2.2
Primary QA Organization (PQAO)	annually	95% of audit percent differences fall within the one point QC check 95% probability intervals at PQAO level of aggregation	40 CFR Part 58 App A sec 4.1.4
<b>Federal Audits (NPAP)</b>	1/year at selected sites 20% of sites audited	Mean absolute difference $\leq 15\%$	40 CFR Part 58 App A sec 2.4
<b>State audits</b>	1/year	State requirements	
<b>Verification/Calibration</b>	Upon receipt/adjustment/repair/ installation/moving 1/6 months if manual zero/span performed biweekly 1/year if continuous zero/span performed daily	Intrument residence time $\leq 2$ min Dynam. parameter $\geq 2.75$ ppm-min All points within $\pm 2\%$ of full scale of best-fit straight line	Multi-point calibration (0 and 4 upscale points) 40 CFR Part 50 App F
<b>Converter Efficiency</b>	During multi-point calibrations, span and audit 1/ 2 weeks	96%	
<b>Gaseous Standards</b>		NIST Traceable	Vendor must participate in EPA Protocol Gas

Requirement	Frequency	Acceptance Criteria	Information /Action
		(e.g., EPA Protocol Gas)	Verification Program 40 CFR Part 58 App A sec 2.6.1
<b>Zero Air/ Zero Air Check</b>	1/year	Concentrations below LDL	
<b>Gas Dilution Systems</b>	1/3 months	Accuracy $\pm$ 2 %	
<b>Detection</b>			
Noise	NA	0.005 ppm	40 CFR Part 53.20
Lower detectable level	1/year	0.01 ppm	40 CFR Part 53.20
<b>SYSTEMATIC CRITERIA- NO<sub>2</sub></b>			
<b>Standard Reporting Units</b>	All data	ppm (final units in AQS)	
<b>Completeness</b> (seasonal)	Quarterly	75%	Annual standard (hourly data)
<b>Sample Residence Times</b>		< 20 seconds	
<b>Sample Probe, Inlet, Sampling train</b>		Borosilicate glass (e.g., Pyrex <sup>®</sup> ) or Teflon <sup>®</sup>	40 CFR Part 58 App E
<b>Siting</b>		Un-obstructed probe inlet	40 CFR Part 58 App E

**SO<sub>2</sub> Validation Template**

Requirement	Frequency	Acceptance Criteria	Information /Action
<b>CRITICAL CRITERIA- SO<sub>2</sub></b>			
<b>One Point QC Check Single analyzer</b>	1/ 2 weeks	≤ ±10% (percent difference)	0.01 - 0.10 ppm Relative to routine concentrations 40 CFR Part 58 App A Sec 3.2
<b>Zero/span check</b>	1/ 2 weeks	Zero drift ≤ ± 3% of full scale Span drift ≤ ± 10 %	
<b>OPERATIONAL CRITERIA- SO<sub>2</sub></b>			
<b>Shelter Temperature</b>			
Temperature range	<b>Daily</b> (hourly values)	20 to 30° C. (Hourly ave) or per manufacturers specifications if designated to a wider temperature range	Generally the 20-30 ° C range will apply but the most restrictive operable range of the instruments in the shelter may also be used as guidance
Temperature Control	Daily (hourly values)	≤ ± 2° C SD over 24 hours	
Temperature Device Check	2/year	± 2° C of standard	
<b>Precision (using 1-point QC checks)</b>	Calculated annually and as appropriate for design value estimates	90% CL CV ≤ 10%	90% Confidence Limit of coefficient of variation 40 CFR Part 58 App A sec 4.1.2
<b>Bias (using 1-point QC checks)</b>	Calculated annually and as appropriate for design value estimates	95% CL ≤ ± 10%	95% Confidence Limit of absolute bias estimate 40 CFR Part 58 App A sec 4.1.3
<b>Annual Performance Evaluation</b>			
Single analyzer	Every site 1/year 25 % of sites quarterly	Percent difference of each audit level ≤ 15%	3 consecutive audit concentrations not including zero 40 CFR Part 58 App A sec 3.2.2
Primary QA Organization (PQAO)	annually	95% of audit percent differences fall within the one point QC check 95% probability intervals at PQAO level of aggregation	40 CFR Part 58 App A sec 4.1.4
<b>Federal Audits (NPAP)</b>	1/year at selected sites 20% of sites audited	Mean absolute difference ≤ 15%	40 CFR Part 58 App A sec 2.4
<b>State audits</b>	1/year	State requirements	
<b>Verification/Calibration</b>	Upon receipt/adjustment/repair/ installation/moving 1/6 months if manual zero/span performed biweekly 1/year if continuous zero/span performed daily	All points within ± 2 % of full scale of best-fit straight line	Multi-point calibration (0 and 4 upscale points)
<b>Zero Air</b>		Concentrations below LDL	
<b>Gaseous Standards</b>		NIST Traceable (e.g., EPA Protocol Gas)	Vendor must participate in EPA Protocol Gas Verification Program 40 CFR Part 58 App A sec 2.6.1

Requirement	Frequency	Acceptance Criteria	Information /Action
<b>Zero Air/ Zero Air Check</b>	1/year	Concentrations below LDL	
<b>Gas Dilution Systems</b>	1/3 months	Accuracy ± 2 %	
<b>Detection</b>			
Noise	NA	0.005 ppm	40 CFR Part 53.20
Lower detectable level	1/year	0.01 ppm	40 CFR Part 53.20
<b>SYSTEMATIC CRITERIA- SO<sub>2</sub></b>			
<b>Standard Reporting Units</b>	All data	ppm (final units in AQS)	
<b>Completeness (seasonal)</b>	Quarterly	75%	Annual standard
	24 hours	75%	24-hour standard
	3 hours	75%	3-hour standard
<b>Sample Residence Times</b>		< 20 seconds	
<b>Sample Probe, Inlet, Sampling train</b>		Borosilicate glass (e.g., Pyrex <sup>®</sup> ) or Teflon <sup>®</sup>	40 CFR Part 58 App E
<b>Siting</b>		Un-obstructed probe inlet	40 CFR Part 58 App E



**PM<sub>2.5</sub> Filter Based Local Conditions Validation Template**

Criteria	Frequency	Acceptable Range	Information (CFR or Method 2.12)
<b>CRITICAL CRITERIA- PM<sub>2.5</sub> Filter Based Local Conditions</b>			
<b>Filter Holding Times</b>			
Sample Recovery	all filters	≤ 7 days 9 hours from sample end date	Part 50 App L Sec 10.10
Post-sampling Weighing	all filters	≤ 10 days from sample end date if shipped at ambient temp, or ≤ 30 days if shipped below ave ambient (or 4° C or below for ave sampling temps < 4° C ) from sample end date	Part 50 App L Sec 8..3.6
<b>Sampling Period (including multiple power failures)</b>	all filters	1380-1500 minutes, or value if < 1380 and exceedance of NAAQS <sup>1/</sup> midnight to midnight	Part 50 App L Sec 3.3 Part 50, App.L Sec 7.4.15
<b>Sampling Instrument</b>			
Average Flow Rate	every 24 hours of op	average within 5% of 16.67 liters/minute	Part 50 App L Sec 7.4
Variability in Flow Rate	every 24 hours of op	CV ≤ 2%	Part 50, App.L Sec 7.4.3.2
<b>Filter</b>			
Visual Defect Check (unexposed)	all filters	see reference	Part 50, App.L Sec 10.2
<b>Filter Conditioning Environment</b>			
Equilibration	all filters	24 hours minimum	Part 50, App.L Sec 8.2
Temp. Range	all filters	24-hr mean 20-23° C	Part 50, App.L Sec 8.2
Temp.Control	all filters	± 2° C SD* over 24 hr	Part 50, App.L Sec 8.2
Humidity Range	all filters	24-hr mean 30% - 40% RH or ≤ 5% sampling RH but > 20%RH	Part 50, App.L Sec 8.2
Humidity Control	all filters	± 5% SD* over 24 hr.	Part 50, App.L Sec 8.2
Pre/post Sampling RH	all filters	difference in 24-hr means ≤ ± 5% RH	Part 50, App.L Sec 8.3.3
Balance	all filters	located in filter conditioning environment	Part 50, App.L Sec 8.3.2
<b>Verification/Calibration</b>			
One-point Flow Rate Verification	1/4 weeks	± 4% of transfer standard	Part 50, App.L, Sec 9.2.5 Part 58, Appendix A Sec 3.2.3 & 3.3.2
<b>OPERATIONAL EVALUATIONS TABLE PM<sub>2.5</sub> Filter Based Local Conditions</b>			
<b>Filter Checks</b>			
Lot Blanks	9 filters per lot	less than 15 µg change between weighings	Method 2.12 Sec. 7.7
Exposure Lot Blanks	3 filters per lot	less than 15 µg change between weighings	Method 2.12 Sec. 7.7
Filter Integrity (exposed)	each filter	no visual defects	Method 2.12 Sec. 8.2
<b>Filter Holding Times</b>			
Pre-sampling	all filters	< 30 days before sampling	Part 50, App.L Sec 8.3
<b>Lab QC Checks</b>			
Field Filter Blank	10% or 1 per weighing session	± 30 µg change between weighings	Part 50, App.L Sec 8.3
Lab Filter Blank	10% or 1 per weighing session	± 15 µg change between weighings	Part 50, App.L Sec 8.3
Balance Check	beginning, 10th sample, end	≤ 3 µg	Method Sec. 7.9
Duplicate Filter Weighing	1 per weighing session	± 15 µg change between weighings	Method Sec 7.11
<b>Sampling Instrument</b>			

Criteria	Frequency	Acceptable Range	Information (CFR or Method 2.12)
Individual Flow Rates	every 24 hours of op	no flow rate excursions > ±5% for > 5 min. <sup>1/</sup>	Part 50, App.L Sec 7.4.3.1
Filter Temp Sensor	every 24 hours of op	no excursions of > 5° C lasting longer than 30 min <sup>1/</sup>	Part 50, App.L Sec 7.4
<b>Verification/Calibration</b>			
<b>Routine Verifications</b>			
External Leak Check	every 5 sampling events	< 80 mL/min	Part 50, App.L, Sec 7.4
Internal Leak Check	every 5 sampling events	< 80 mL/min	Part 50, App.L, Sec 7.4
One-point Temp Verification	1/4 weeks	± 2° C	Part 50, App.L, Sec 9.3
Pressure Verification	1/4 weeks	± 10 mm Hg	Part 50, App.L, Sec 9.3
Lab Temperature	1/6 months	± 2° C	Method Sec 3.3
Lab Humidity	1/6 months	± 2%	Method Sec 3.3
<b>Annual Multi-point Verifications /Calibrations</b>			
Temperature multi-point Verification/Calibration	1/yr	± 2° C	Part 50, App.L, Sec 9.3
Pressure Verification/Calibration	on installation, then 1/yr	± 10 mm Hg	Part 50, App.L, Sec 9.3
Flow Rate Multi-point Verification/Calibration	1/yr	± 2% of transfer standard	Part 50, App.L, Sec 9.2
Design Flow Rate Adjustment	at one-point or multi-point	± 2% of design flow rate	Part 50, App.L, Sec 9.2.6
Other Monitor Calibrations	per manufacturers' op manual	per manufacturers' operating manual	
Mirobalance Calibration	1/yr	Manufacturer's specification	Part 50, App.L, Sec 8.1
<b>Precision</b>			
Collocated Samples	every 12 days for 15% of sites	CV ≤ 10% of samples > 3 µg/m <sup>3</sup>	Part 58 App A Sec 3.2.5
<b>Accuracy</b>			
Temperature Audit	2/yr	± 2° C	Method Sec. 10.2
Pressure Audit	2/yr	± 10 mm Hg	Method Sec. 10.2
Balance Audit	1/yr	± 0.050 mg or manufacturers specs, whichever is tighter	Method Sec. 10.2
Semi Annual Flow Rate Audit	2/yr	± 4% of audit standard ± 5% of design flow rate	Part 58, App A, Sec 3.3.3
<b>Calibration &amp; Check Standards -</b>			
Field Thermometer	1/yr	± 0.1° C resolution, ± 0.5° C accuracy	Method Sec 4.2 & 6.4
Field Barometer	1/yr	± 1 mm Hg resolution, ± 5 mm Hg accuracy	Method Sec 4.2 & 6.5
Working Mass Stds. (compare to primary standards)	1/3 mo.	0.025 mg	Method Sec 4.3 and 7.3
<b>Monitor Maintenance</b>			
Impactor (WINS) Very Sharp Cut Cyclone	every 5 sampling events Every 30 days	cleaned/changed	Method Sec 9.2
Inlet/downtube Cleaning	every 15 sampling events	cleaned	Method Sec 9.3
Filter Chamber Cleaning	1/4 weeks	cleaned	Method Sec 9.3

Criteria	Frequency	Acceptable Range	Information (CFR or Method 2.12)
Leak Check <sup>@</sup>		see <i>Verification/Calibration</i>	
Circulating Fan Filter Cleaning	1/4 weeks	cleaned/changed	Method Sec 9.3
Manufacturer-Recommended Maintenance	per manufacturers' SOP	per manufacturers' SOP	
<b>SYSTEMATIC CRITERIA -PM<sub>2.5</sub> Filter Based Local Conditions</b>			
<b>Data Completeness</b>	quarterly	≥ 75%	Part 50, App. N, Sec. 4.1 (b) 4.2 (a)
<b>Reporting Units</b>	all filters	μg/m <sup>3</sup> at ambient temp/pressure (PM <sub>2.5</sub> )	Part 50.3
<b>Rounding Convention</b>			
Annual 3-yr average	quarterly	nearest 0.1 μg/m <sup>3</sup> (≥ 0.05 round up)	Part 50, App. N Sec 2.3
24-hour, 3-year average	quarterly	nearest 1 μg/m <sup>3</sup> (≥ 0.5 round up)	Part 50, App. N Sec 2.3
<b>Detection Limit</b>			
Lower DL	all filters	≤ 2 μg/m <sup>3</sup>	Part 50, App.L Sec 3.1
Upper Conc. Limit	all filters	≥ 200 μg/m <sup>3</sup>	Part 50, App.L Sec 3.2
<b>Verification/Calibration Standards Recertifications – All standards should have multi-point certifications against NIST Traceable standards</b>			
Flow Rate Transfer Std.	1/yr	± 2% of NIST-traceable Std.	Part 50, App.L Sec 9.1 & 9.2
Field Thermometer	1/yr	± 0.1° C resolution, ± 0.5° C accuracy	Method Sec 4.2.2
Field Barometer	1/yr	± 1 mm Hg resolution, ± 5 mm Hg accuracy	Method Sec 4.2.2
Primary Mass Stds. (compare to NIST-traceable standards)	1/yr	0.025 mg	Method Sec 4.3.7
<b>Microbalance</b>			
Readability	at purchase	1 μg	Part 50, App.L Sec 8.1
Repeatability	1/yr	1 μg	
<b>Calibration &amp; Check Standards</b>			
Flow Rate Transfer Std.	1/yr	± 2% of NIST-traceable Std.	Part 50, APP L, Sec 9.1 & 9.2
<b>Verification/Calibration</b>			
Clock/timer Verification	1/4 weeks	1 min/mo	Part 50, App.L, Sec 7.4
<b>Precision</b>			
Single analyzer	1/3 mo.	Coefficient of variation (CV) ≤ 10%	
Single analyzer	1/ yr	CV ≤ 10%	
Primary Quality Assurance Org.	Annual and 3 year estimates	90% CL of CV ≤ 10%	Part 58, App A, Sec 4.3.1
<b>Bias</b>			
Performance Evaluation Program (PEP)	5 audits for PQAOs with ≤ 5 sites 8 audits for PQAOs with > 5 sites	± 10%	Part 58, App A, Sec 3.2.7, 4.3.2

1/ value must be flagged \* SD= standard deviation CV= coefficient of variation @ = Scheduled to occur immediately after impactor cleaned/changed.

**NOTE:** There may be a number of continuous monitors that may be designated as an FEM or an ARM. These monitors may have different measurement or sampling attributes that cannot be identified in this validation template. Monitoring organizations should review specific instrument operating manuals to augment this validation template as necessary. In general, 40 CFR Part 58 App A and 40 CFR part 50 App L requirements apply to Continuous PM2.5

**Continuous PM2.5 Local Conditions Validation Template**

Criteria	Frequency	Acceptable Range	Information (CFR or Method 2.12)
<b>CRITICAL CRITERIA- PM<sub>2.5</sub> Continuous, Local Conditions</b>			
<b>Sampling Period</b> 24 hour estimate	every sample period	1380-1500 minutes, or value if < 1380 and exceedance of NAAQS <sup>1/</sup> midnight to midnight	Part 50 App L Sec 3.3 Part 50, App.L Sec 7.4.15
Hour estimate	Every hour	Instrument dependent	See operators manual
<b>Sampling Instrument</b>			
Average Flow Rate	every 24 hours of op	average within 5% of 16.67 liters/minute	Part 50 App L Sec 7.4
Variability in Flow Rate	every 24 hours of op	CV ≤ 2%	Part 50, App.L Sec 7.4.3.2
<b>Verification/Calibration</b>			
One-point Flow Rate Verification	1/4 weeks	± 4% of transfer standard	Part 50, App.L, Sec 9.2.5 Part 58, Appendix A Sec 3.2.3 & 3.3.2
Reference Membrane Verification (BAM)	Hourly	± 4% of ABS Value	
<b>OPERATIONAL CRITERIA- PM<sub>2.5</sub> Continuous, Local Conditions</b>			
<b>Verification/Calibration</b>			
Leak Check	every 30 days	Instrument dependent	Part 50, App.L, Sec 7.4
Temperature Calibration	if multi-point failure	± 2°C	Part 50, App.L, Sec 9.3
Temp M-point Verification	on installation, then 1/yr	± 2°C	Part 50, App.L, Sec 9.3
One-point Temp Check	1/4 weeks	± 2°C	Part 50, App.L, Sec 9.3
Pressure Calibration	on installation, then 1/yr	± 10 mm Hg	Part 50, App.L, Sec 9.3
Pressure Verification	1/4 weeks	± 10 mm Hg	Part 50, App.L, Sec 9.3
Other Monitor Calibrations	per manufacturers' op manual	per manufacturers' operating manual	
Flow Rate (FR) Calibration	if multi-point verification failure	± 2%	Part 50, App.L, Sec 9.2
FR Multi-point Verification	1/yr	± 2%	Part 50, App.L, Sec 9.2
Design Flow Rate Adjustment	at one-point or multi-point	± 2% of design flow rate	Part 50, App.L, Sec 9.2.6
<b>Precision</b>			
Collocated Samples	every 12 days for 15% of sites	CV ≤ 10% of samples > 3 µg/m <sup>3</sup>	Part 58 App A Sec 3.2.5

Criteria	Frequency	Acceptable Range	Information (CFR or Method 2.12)
<b>Accuracy</b>			
Temperature Audit	2/yr	± 2°C	Method 2.12 Sec. 10.2
Pressure Audit	2/yr	± 10 mm Hg	Method 2.12 Sec. 10.2
Semi Annual Flow Rate Audit	2/yr	± 4% of audit standard ± 5% of design flow rate	Method 2.12 Sec. 10.2
<b>Calibration &amp; Check Standards (working standards)</b>			
Field Thermometer	1/yr	± 0.1° C resolution, ± 0.5° C accuracy	Method 2.12 Sec 4.2 & 6.4
Field Barometer	1/yr	± 1 mm Hg resolution, ± 5 mm Hg accuracy	Method 2.12 Sec 4.2 & 6.5
<b>Shelter Temperature</b>			
Temperature range	<b>Daily</b> (hourly values)	20 to 30° C. (Hourly ave) or per manufacturers specifications if designated to a wider temperature range	Generally the 20-30 ° C range will apply but the most restrictive operable range of the instruments in the shelter may also be used as guidance
Temperature Control	Daily (hourly values)	≤ ± 2° C SD over 24 hours	
Temperature Device Check	2/year	± 2°C	
<b>Monitor Maintenance</b>			
Virtual Impactor Very Sharp Cut Cyclone	Every 30 days	cleaned/changed	Method 2.12 Sec 9.2
Inlet Cleaning	Every 30 days	cleaned	Method 2.12 Sec 9.3
Filter Chamber Cleaning	1/4 weeks	cleaned	Method 2.12 Sec 9.3
Circulating Fan Filter Cleaning	1/4 weeks	cleaned/changed	Method 2.12 Sec 9.3
Manufacturer-Recommended Maintenance	per manufacturers' SOP	per manufacturers' SOP	
<b>SYSTEMATIC CRITERIA- PM<sub>2.5</sub> Continuous, Local Conditions</b>			
<b>Data Completeness</b>	quarterly	≥ 75%	Part 50, App. N, Sec. 4.1 (b) 4.2 (a)
<b>Reporting Units</b>		µg/m <sup>3</sup> at ambient temp/pressure (PM <sub>2.5</sub> )	Part 50.3
<b>Rounding Convention</b>			
Annual 3-yr average	quarterly	nearest 0.1 µg/m <sup>3</sup> (≥ 0.05 round up)	Part 50, App. N Sec 2.3
24-hour, 3-year average	quarterly	nearest 1 µg/m <sup>3</sup> (≥ 0.5 round up)	Part 50, App. N Sec 2.3
<b>Detection Limit</b>			
Lower DL	all filters	≤ 2 µg/m <sup>3</sup>	Part 50, App.L Sec 3.1
Upper Conc. Limit	all filters	≥ 200 µg/m <sup>3</sup>	Part 50, App.L Sec 3.2
<b>Verification/Calibration Standards Recertifications - All standards should have multi-point certifications against NIST Traceable standards</b>			

Criteria	Frequency	Acceptable Range	Information (CFR or Method 2.12)
Flow Rate Transfer Std.	1/yr	± 2% of NIST-traceable Std.	Part 50, App.L Sec 9.1 & 9.2
Field Thermometer	1/yr	± 0.1° C resolution, ± 0.5° C accuracy	Method 2.12 Sec 4.2.2
Field Barometer	1/yr	± 1 mm Hg resolution, ± 5 mm Hg accuracy	Method 2.12 Sec 4.2.2
<b>Calibration &amp; Check Standards</b>			
Flow Rate Transfer Std.	1/yr	± 2% of NIST-traceable Std.	Part 50, APP L, Sec 9.1 & 9.2
<b>Verification/Calibration</b>			
Clock/timer Verification	1/4 weeks	1 min/mo**	Part 50, App.L, Sec 7.4
<b>Precision</b>			
Single analyzer	1/3 mo.	Coefficient of variation (CV) ≤ 10%	
Single analyzer	1/ yr	CV ≤ 10%	
Primary Quality Assurance Org.	Annual and 3 year estimates	90% CL of CV ≤ 10%	Part 58, App A, Sec 4.3.1
<b>Bias</b>			
Performance Evaluation Program (PEP)	5 audits for PQAOs with ≤ 5 sites 8 audits for PQAOs with > 5 sites	± 10%	Part 58, App A, Sec 3.2.7, 4.3.2

1/ value must be flagged due to current implementation of BAM ( sampling 42 minute/hour) only 1008 minutes of sampling in 24 hour period

\*= not defined in CFR

SD= standard deviation

CV= coefficient of variation

@ = Scheduled to occur immediately after impactor cleaned/changed.

\*\* = need to ensure data system stamps appropriate time period with reported sample value

**NOTE:** The following validation template was constructed for use of PM<sub>10</sub> at **local conditions** where PM<sub>10</sub> is used in the calculation of the PM<sub>10-2.5</sub> measurement or for objectives other than comparison to the PM<sub>10</sub> NAAQS. Although the PM<sub>10-2.5</sub> method is found in 40 CFR Part 50 Appendix O, Appendix O references Appendix L (the PM<sub>2.5</sub> Method) for the QC requirements listed below. Monitoring organizations using PM<sub>10</sub> data for a NAAQS comparison purposes should refer to the PM<sub>10</sub> validation template for **STP** (standard temperature and pressure correction).

**PM<sub>10</sub> Filter Based Local Conditions Validation Template**

Criteria	Frequency	Acceptable Range	Information (CFR or Method 2.12)
<b>CRITICAL CRITERIA- PM<sub>10</sub> Filter Based Local Conditions</b>			
<b>Filter Holding Times</b>			
Sample Recovery	all filters	≤ 7 days 9 hours from sample end date	Part 50 App L Sec 10.10
Post-sampling Weighing	all filters	≤ 10 days from sample end date if shipped at ambient temp, or ≤ 30 days if shipped below ave ambient (or 4° C or below for ave sampling temps < 4° C ) from sample end date	Part 50 App L Sec 8.3.6
<b>Sampling Period (including multiple power failures)</b>	all filters	1380-1500 minutes, or value if < 1380 and exceedance of NAAQS <sup>1/</sup> midnight to midnight	Part 50 App L Sec 3.3 Part 50, App.L Sec 7.4.15
<b>Sampling Instrument</b>			
Average Flow Rate	every 24 hours of op	average within 5% of 16.67 liters/minute	Part 50 App L Sec 7.4
Variability in Flow Rate	every 24 hours of op	CV ≤ 2%	Part 50, App.L Sec 7.4.3.2
<b>Filter</b>			
Visual Defect Check (unexposed)	all filters	see reference	Part 50, App.L Sec 10.2
Filter Conditioning Environment			
Equilibration	all filters	24 hours minimum	Part 50, App.L Sec 8.2
Temp. Range	all filters	24-hr mean 20-23° C	Part 50, App.L Sec 8.2
Temp.Control	all filters	± 2° C SD* over 24 hr	Part 50, App.L Sec 8.2
Humidity Range	all filters	24-hr mean 30% - 40% RH or ≤ 5% sampling RH but > 20%RH	Part 50, App.L Sec 8.2
Humidity Control	all filters	± 5% SD* over 24 hr.	Part 50, App.L Sec 8.2
Pre/post Sampling RH	all filters	difference in 24-hr means ≤ ± 5% RH	Part 50, App.L Sec 8.3.3
Balance	all filters	located in filter conditioning environment	Part 50, App.L Sec 8.3.2
<b>Verification/Calibration</b>			

Criteria	Frequency	Acceptable Range	Information (CFR or Method 2.12)
One-point Flow Rate Verification	1/4 weeks	± 4% of transfer standard	Part 50, App.L, Sec 9.2.5 Part 58, Appendix A Sec 3.2.3 & 3.3.2
<b>OPERATIONAL EVALUATIONS TABLE PM<sub>10</sub> Filter Based Local Conditions</b>			
<b>Filter Checks</b>			
Lot Blanks	9 filters per lot	less than 15 µg change between weighings	Method 2.12 Sec. 7.7
Exposure Lot Blanks	3 filters per lot	less than 15 µg change between weighings	Method 2.12 Sec. 7.7
Filter Integrity (exposed)	each filter	no visual defects	Method 2.12 Sec. 8.2
<b>Filter Holding Times</b>			
Pre-sampling	all filters	< 30 days before sampling	Part 50, App.L Sec 8.3
<b>Lab QC Checks</b>			
Field Filter Blank	10% or 1 per weighing session	± 30 µg change between weighings	Part 50, App.L Sec 8.3
Lab Filter Blank	10% or 1 per weighing session	± 15 µg change between weighings	Part 50, App.L Sec 8.3
Balance Check	beginning, 10th sample, end	≤ 3 µg	Method Sec. 7.9
Duplicate Filter Weighing	1 per weighing session	± 15 µg change between weighings	Method Sec 7.11
<b>Sampling Instrument</b>			
Individual Flow Rates	every 24 hours of op	no flow rate excursions > ±5% for > 5 min. <sup>1/</sup>	Part 50, App.L Sec 7.4.3.1
Filter Temp Sensor	every 24 hours of op	no excursions of > 5° C lasting longer than 30 min <sup>1/</sup>	Part 50, App.L Sec 7.4
<b>Verification/Calibration</b>			
<b>Routine Verifications</b>			
External Leak Check	every 5 sampling events	< 80 mL/min	Part 50, App.L, Sec 7.4
Internal Leak Check	every 5 sampling events	< 80 mL/min	Part 50, App.L, Sec 7.4
One-point Temp Verification	1/4 weeks	± 2° C	Part 50, App.L, Sec 9.3
Pressure Verification	1/4 weeks	± 10 mm Hg	Part 50, App.L, Sec 9.3
Lab Temperature	1/6 months	± 2° C	Method Sec 3.3
Lab Humidity	1/6 months	± 2%	Method Sec 3.3
<b>Annual Multi-point Verifications /Calibrations</b>			
Temperature multi-point Verification/Calibration	1/yr	± 2° C	Part 50, App.L, Sec 9.3
Pressure Verification/Calibration	on installation, then 1/yr	± 10 mm Hg	Part 50, App.L, Sec 9.3
Flow Rate Multi-point Verification/Calibration	1/yr	± 2% of transfer standard	Part 50, App.L, Sec 9.2



Criteria	Frequency	Acceptable Range	Information (CFR or Method 2.12)
Design Flow Rate Adjustment	at one-point or multi-point	± 2% of design flow rate	Part 50, App.L, Sec 9.2.6
Other Monitor Calibrations	per manufacturers' op manual	per manufacturers' operating manual	
Mirobalance Calibration	1/yr	Manufacturer's specification	Part 50, App.L, Sec 8.1
<b>Precision</b>			
Collocated Samples	every 12 days for 15% of sites	CV ≤ 10% of samples > 3 µg/m <sup>3</sup>	Part 58 App A Sec 3.2.5
<b>Accuracy</b>			
Temperature Audit	2/yr	± 2°C	Method Sec. 10.2
Pressure Audit	2/yr	± 10 mm Hg	Method Sec. 10.2
Balance Audit	1/yr	± 0.050 mg or manufacturers specs, whichever is tighter	Method Sec. 10.2
Semi Annual Flow Rate Audit	2/yr	± 4% of audit standard ± 5% of design flow rate	Part 58, App A, Sec 3.3.3
<b>Calibration &amp; Check Standards</b> (working standards)			
Field Thermometer	1/yr	± 0.1° C resolution, ± 0.5° C accuracy	Method Sec 4.2 & 6.4
Field Barometer	1/yr	± 1 mm Hg resolution, ± 5 mm Hg accuracy	Method Sec 4.2 & 6.5
Working Mass Stds. (compare to primary standards)	1/3 mo.	0.025 mg	Method Sec 4.3 and 7.3
<b>Monitor Maintenance</b>			
Inlet/downtube Cleaning	every 15 sampling events	cleaned	Method Sec 9.3
Filter Chamber Cleaning	1/4 weeks	cleaned	Method Sec 9.3
Leak Check <sup>®</sup>		see <i>Verification/Calibration</i>	
Circulating Fan Filter Cleaning	1/4 weeks	cleaned/changed	Method Sec 9.3
Manufacturer-Recommended Maintenance	per manufacturers' SOP	per manufacturers' SOP	
<b>SYSTEMATIC CRITERIA -PM<sub>10</sub> Filter Based Local Conditions</b>			
<b>Data Completeness</b>	quarterly	≥ 75%	Part 50, App. N, Sec. 2.1
<b>Reporting Units</b>	all filters	µg/m <sup>3</sup> at ambient temp/pressure (PM <sub>2.5</sub> )	Part 50.3
<b>Rounding Convention</b>			
Annual 3-yr average	quarterly	nearest 0.1 µg/m <sup>3</sup> (≥ 0.05 round up)	Part 50, App. N Sec 2.3
24-hour, 3-year average	quarterly	nearest 1 µg/m <sup>3</sup> (≥ 0.5 round up)	Part 50, App. N Sec 2.3
<b>Detection Limit</b>			
Lower DL	all filters	≤ 2 µg/m <sup>3</sup>	Part 50, App.L Sec 3.1

Criteria	Frequency	Acceptable Range	Information (CFR or Method 2.12)
Upper Conc. Limit	all filters	$\geq 200 \mu\text{g}/\text{m}^3$	Part 50, App.L Sec 3.2
<b>Verification/Calibration Standards Recertifications- All standards should have multi-point certifications against NIST Traceable standards</b>			
Flow Rate Transfer Std.	1/yr	$\pm 2\%$ of NIST-traceable Std.	Part 50, App.L Sec 9.1 & 9.2
Field Thermometer	1/yr	$\pm 0.1^\circ \text{C}$ resolution, $\pm 0.5^\circ \text{C}$ accuracy	Method Sec 4.2.2
Field Barometer	1/yr	$\pm 1 \text{ mm Hg}$ resolution, $\pm 5 \text{ mm Hg}$ accuracy	Method Sec 4.2.2
Primary Mass Stds. (compare to NIST-traceable standards)	1/yr	0.025 mg	Method Sec 4.3.7
<b>Microbalance</b>			
Readability	at purchase	1 $\mu\text{g}$	Part 50, App.L Sec 8.1
Repeatability	1/yr	1 $\mu\text{g}$	
<b>Calibration &amp; Check Standards</b>			
Flow Rate Transfer Std.	1/yr	$\pm 2\%$ of NIST-traceable Std.	Part 50, APP L, Sec 9.1 & 9.2
<b>Verification/Calibration</b>			
Clock/timer Verification	1/4 weeks	1 min/mo	Part 50, App.L, Sec 7.4
<b>Precision</b>			
Single analyzer	1/3 mo.	Coefficient of variation (CV) $\leq 10\%$	
Single analyzer	1/ yr	CV $\leq 10\%$	
Primary Quality Assurance Org.	Annual and 3 year estimates	90% CL of CV $\leq 10\%$	Part 58, App A, Sec 4.3.1
<b>Bias</b>			
Performance Evaluation Program (PEP)	5 audits for PQAOs with $\leq 5$ sites 8 audits for PQAOs with $> 5$ sites	$\pm 10\%$	Part 58, App A, Sec 3.2.7, 4.3.2

1/ value must be flagged

SD= standard deviation

CV= coefficient of variation

@ = Scheduled to occur immediately after impactor cleaned/changed.

**PM<sub>10</sub> Filter Based Dichot **STP** Conditions Validation Template**

Criteria	Frequency	Acceptable Range	Information (CFR or Method 2.10)
<b>CRITICAL CRITERIA- PM<sub>10</sub> Filter Based Dichot</b>			
<b>Filter Holding Times</b>			
Sample Recovery	all filters	ASAP	Part 50 App J sec 9.16
<b>Sampling Period</b>	all filters	1440 minutes ± 60 minutes midnight to midnight	Part 50 App J sec 7.1.5
<b>Sampling Instrument</b>			
Average Flow Rate	every 24 hours of op	average 16.67 liters/minute	Method 2.10 sec 2.1
<b>Filter</b>			
Visual Defect Check (unexposed)	all filters	see reference	Method 2.10 sec 4.2
Collection efficiency	all filters	99 %	Part 50, App J sec 7.2.2
Integrity	all filters	± 5 µg/m <sup>3</sup>	Part 50, App J sec 7.2.3
Alkalinity	all filters	< 25.0 microequivalents/gram	Part 50, App J sec 7.2.4
<b>Filter Conditioning Environment</b>			
Equilibration	all filters	24 hours minimum	Part 50, App.J sec 9.3
Temp. Range	all filters	15-30° C	Part 50, App.J sec 7.4.1
Temp.Control	all filters	± 3° C SD* over 24 hr	Part 50, App.J sec 7.4.2
Humidity Range	all filters	20% - 45% RH	Part 50, App.J sec 7.4.3
Humidity Control	all filters	± 5% SD* over 24 hr	Part 50, App.J sec 7.4.4
Pre/post Sampling RH	all filters	difference in 24-hr means ≤ ± 5% RH	Part 50, App.L sec 8.3.3
Balance	all filters	located in filter conditioning environment	Part 50, App.L sec 8.3.2
<b>Verification/Calibration</b>			
One-point Flow Rate Verification	1/4 weeks	± 7% of transfer standard and 10% from design	Method 2.10 sec Table 3-1
<b>OPERATIONAL EVALUATIONS TABLE PM<sub>10</sub> Filter Based Dichot</b>			
<b>Lab QC Checks</b>			
Balance Check	beginning, 10th sample, end	≤4 µg of true zero ≤2 µg of 10 mg check weight	Method 2.10 sec 4.5
“Standard” filter QC check	10%	± 20 µg change from original value	Method 2.10 sec 4.5 From standard non-routine filter
“Routine” duplicate weighing	5-7 per weighing session	± 20 µg change from original value	Method 2.10 sec 4.5 From routine filter set
<b>Verification/Calibration</b>			
System Leak Check	During precalibration check	Vacuum of 10 to 15 in. with decline to 0 >60 seconds	Method 2.10 sec 2.2.1
FR Multi-point Verification/Calibration	1/yr	± 2%	Part 50, App.L, sec 9.2
Field Temp M-point Verification	on installation, then 1/yr	± 2° C	
Lab Temperature	1/6 months	± 2° C	recommendation
Lab Humidity	1/6 months	± 2%	recommendation
Microbalance Calibration	1/yr	Manufacturer’s specification	
<b>Precision</b>			

Criteria	Frequency	Acceptable Range	Information (CFR or Method 2.10)
Collocated Samples	every 12 days for 15% of sites	$CV \leq 10\%$ of samples $> 3 \mu\text{g}/\text{m}^3$	Part 58 App A sec 3.2.5
<b>Audits</b>			
Filter Weighing	1/yr	$\pm 20 \mu\text{g}$ change from original value	Method 2.10 Table 7-1
Balance Audit	1/yr	Observe weighing technique and check balance with ASTM Class 1 standard	Method 2.10 Table 7-1 section 7.2.2
Semi Annual Flow Rate Audit	2/yr	$\pm 4\%$ of audit standard $\pm 5\%$ of design flow rate	Part 58, App A, sec 3.3.3
<b>Monitor Maintenance</b>			
Impactor	1/3 mo	cleaned/changed	Method 2.10 sec 6.1.2
Inlet/downtube Cleaning	1/3 mo	cleaned	Method 2.10 sec 6.1.2
Vacuum pump	1/yr	Replace diaphragm and flapper valves	Method 2.10 sec 6.1.3
Manufacturer-Recommended Maintenance	per manufacturers' SOP	per manufacturers' SOP	
<b>SYSTEMATIC CRITERIA - PM<sub>10</sub> Filter Based Dichot</b>			
Data Completeness	quarterly	$\geq 75\%$	Part 50 App. K, sec. 2.3
Reporting Units	all filters	$\mu\text{g}/\text{m}^3$ at standard temperature and pressure (STP)	Part 50 App K
<b>Rounding Convention</b>			
24-hour, 3-year average	quarterly	nearest $10 \mu\text{g}/\text{m}^3$ ( $\geq 5$ round up)	Part 50 App K sec 1
<b>Verification/Calibration Standards and Recertifications - All standards should have multi-point certifications against NIST Traceable standards</b>			
Flow Rate Transfer Std.	1/yr	$\pm 2\%$ of NIST-traceable Std.	Part 50, App.J sec 7.3
Field Thermometer	1/yr	$\pm 0.1^\circ\text{C}$ resolution, $\pm 0.5^\circ\text{C}$ accuracy	
Field Barometer	1/yr	$\pm 1 \text{ mm Hg}$ resolution, $\pm 5 \text{ mm Hg}$ accuracy	
Primary Mass Stds. (compare to NIST-traceable standards)	1/yr	NIST traceable (e.g., ANSI/ASTM Class 1, 1.1 or 2)	Method 2.10 sec 9
<b>Microbalance</b>			
Readability	at purchase	$1 \mu\text{g}$	Method 2.10 sec 4.4
Repeatability	1/yr	$1 \mu\text{g}$	Method 2.10 sec 4.4
<b>Calibration &amp; Check Standards</b>			
Flow Rate Transfer Std.	1/yr	$\pm 2\%$ of NIST-traceable Std.	Method 2.10 sec 9
<b>Verification/Calibration</b>			
Clock/timer Verification	4/year	5 min/mo	recommendation
<b>Precision</b>			
Single analyzer	1/3 mo.	Coefficient of variation (CV) $\leq 10\%$	recommendation
Single analyzer	1/ yr	$CV \leq 10\%$	recommendation
Primary Quality Assurance Org.	Annual and 3 year estimates	90% CL of $CV \leq 10\%$	Part 58, App A, sec 4.3.1

SD= standard deviation CV= coefficient of variation

**PM<sub>10</sub> Filter Based High Volume (HV) STP Conditions Validation Template**

Criteria	Frequency	Acceptable Range	Information (CFR or Method 2.11)
<b>CRITICAL CRITERIA- PM<sub>10</sub> Filter Based Hi-Vol</b>			
<b>Filter Holding Times</b>			
Sample Recovery	all filters	ASAP	Part 50 App J sec 9.16
<b>Sampling Period</b>	all filters	1440 minutes ± 60 minutes midnight to midnight	Part 50 App J sec 7.1.5
<b>Sampling Instrument</b>			
Average Flow Rate	every 24 hours of op	~1.13 m <sup>3</sup> /min (varies with instrument)	Method 2.11
<b>Filter</b>			
Visual Defect Check (unexposed)	all filters	see reference	Method 2.10 sec 4.2
Collection efficiency	all filters	99 %	Part 50, App J sec 7.2.2
Integrity	all filters	± 5 µg/m <sup>3</sup>	Part 50, App J sec 7.2.3
Alkalinity	all filters	< 25.0 microequivalents/gram	Part 50, App J sec 7.2.4
<b>Filter Conditioning Environment</b>			
Equilibration	all filters	24 hours minimum	Part 50, App.J sec 9.3
Temp. Range	all filters	15-30° C	Part 50, App.J sec 7.4.1
Temp.Control	all filters	± 3° C SD* over 24 hr	Part 50, App.J sec 7.4.2
Humidity Range	all filters	20% - 45% RH	Part 50, App.J sec 7.4.3
Humidity Control	all filters	± 5% SD* over 24 hr	Part 50, App.J sec 7.4.4
Pre/post Sampling RH	all filters	difference in 24-hr means ≤ ± 5% RH	recommendation
Balance	all filters	located in filter conditioning environment	recommendation
<b>Verification/Calibration</b>			
One-point Flow Rate Verification	1/3 mo	± 7% of transfer standard and 10% from design	Method 2.10 sec Table 3-1
<b>OPERATIONAL EVALUATIONS TABLE PM<sub>10</sub> Filter Based Hi-Vol</b>			
<b>Lab QC Checks</b>			
Balance Check	beginning, 10th sample, end	± 0.5 mg of true zero and ± 0.5 mg 1-5 g check weight	Method 2.11 sec 4.5
“Routine” duplicate weighing	5-7 per weighing session	± 2.8 mg change from original value	Method 2.11 sec 4.5.3 From routine filter set
<b>Verification/Calibration</b>			
System Leak Check	During precalibration check	Auditory inspection with faceplate blocked	Method 2.11 sec 2.3.2
FR Multi-point Verification/Calibration	1/yr	3 of 4 cal points within ± 10% of design	Method 2.11 sec 2.3.2

Criteria	Frequency	Acceptable Range	Information (CFR or Method 2.11)
Field Temp M-point Verification	on installation, then 1/yr	± 2°C	
Lab Temperature	1/6 months	± 2°C	recommendation
Lab Humidity	1/6 months	± 2%	recommendation
Microbalance Calibration	1/yr	Manufacturer's specification	
<b>Precision</b>			
Collocated Samples	every 12 days for 15% of sites	CV ≤ 10% of samples > 15 µg/m <sup>3</sup>	Part 58 App A sec 3.2.5
<b>Audits</b>			
Filter Weighing	1/yr	± 5 mg change from original value	Method 2.11 Table 7-1
Balance Audit	1/yr	Observe weighing technique and check balance with ASTM Class 1 standard	Method 2.10 Table 7-1
Semi Annual Flow Rate Audit	2/yr	± 10% of audit standard and design value	Part 58, App A, sec 3.3.3
<b>Monitor Maintenance</b>			
Inlet/downtube Cleaning	1/3 mo	cleaned	Method 2.11 sec 6
Motor/housing gaskets	1/3 mo	Inspected replaced	Method 2.11 sec 6
Blower motor brushes	600-1000 hours	Replace	Method 2.11 sec 6
Manufacturer-Recommended Maintenance	per manufacturers' SOP	per manufacturers' SOP	
<b>SYSTEMATIC CRITERIA - PM<sub>10</sub> Filter Based Hi-Vol</b>			
<b>Data Completeness</b>	quarterly	≥ 75%	Part 50 App. K, sec. 2.3
<b>Reporting Units</b>	all filters	µg/m <sup>3</sup> at standard temperature and pressure (STP)	Part 50 App K
<b>Rounding Convention</b>			
24-hour, 3-year average	quarterly	nearest 10 µg/m <sup>3</sup> (≥ 5 round up)	Part 50 App K sec 1
<b>Verification/Calibration Standards and Recertifications - All standards should have multi-point certifications against NIST Traceable standards</b>			
Flow Rate Transfer Std.	1/yr	± 2% of NIST-traceable Std.	Part 50, App.J sec 7.3
Field Thermometer	1/yr	± 0.1° C resolution, ± 0.5° C accuracy	
Field Barometer	1/yr	± 1 mm Hg resolution, ± 5 mm Hg accuracy	
Primary Mass Stds. (compare to NIST-traceable standards)	1/yr	NIST traceable (e.g., ANSI/ASTM Class 1, 1.1 or 2)	Method 2.11 sec 9
<b>Microbalance</b>			
Readability	at purchase	0.1 mg	Method 2.11 sec 4.4
Repeatability	1/yr	0.5 mg (HV)	Method 2.11 sec 4.4
<b>Calibration &amp; Check Standards</b>			

<b>Criteria</b>	<b>Frequency</b>	<b>Acceptable Range</b>	<b>Information (CFR or Method 2.11)</b>
Flow Rate Transfer Std.	1/yr	± 2% of NIST-traceable Std.	Method 2.10 sec 9
<b>Verification/Calibration</b>			
Clock/timer Verification	4/year	5 min/mo	recommendation
<b>Precision</b>			
Single analyzer	1/3 mo.	Coefficient of variation (CV) ≤ 10%	recommendation
Single analyzer	1/ yr	CV ≤ 10%	recommendation
Primary Quality Assurance Org.	Annual and 3 year estimates	90% CL of CV ≤ 10%	Part 58, App A, sec 4.3.1

**SD= standard deviation**

**CV= coefficient of variation**

**Continuous PM10 STP Conditions Validation Template**

**NOTE:** There are a number of continuous PM10 monitors that are designated as FEM. These monitors may have different measurement or sampling attributes that cannot be identified in this validation template. Monitoring organizations should review specific instrument operating manuals to augment this validation template as necessary. In general, 40 CFR Part 58 App A and 40 CFR part 50 App J requirements apply to Continuous PM10. Since a guidance document was never developed for continuous PM10, many of the requirements reflect a combination of manual and continuous PM2.5 requirements and are therefore considered recommendations.

Criteria	Frequency	Acceptable Range	Information (CFR or Method 2.11)
<b>CRITICAL CRITERIA- PM<sub>10</sub> Continuous</b>			
Sampling Period	all filters	1440 minutes $\pm$ 60 minutes midnight to midnight	Part 50 App J sec 7.1.5
Sampling Instrument			
Average Flow Rate	every 24 hours of op	Average within $\pm$ 5% of design	recommendation
Verification/Calibration			
One-point Flow Rate Verification	1/mo	$\pm$ 7% of transfer standard and 10% from design	Part 58, App A, sec 3.2.3
<b>OPERATIONAL EVALUATIONS TABLE PM<sub>10</sub> Continuous</b>			
Verification/Calibration			
System Leak Check	During precalibration check	Auditory inspection with faceplate blocked	Method 2.11 sec 2.3.2
FR Multi-point Verification/Calibration	1/yr	3 of 4 cal points within $\pm$ 10% of design	Method 2.11 sec 2.3.2
Audits			
Semi Annual Flow Rate Audit	1/6 mo	$\pm$ 10% of audit standard and design value	Part 58, App A, sec 3.2.4
Monitor Maintenance			
Inlet/downtube Cleaning	1/3 mo	cleaned	Method 2.11 sec 6
Motor/housing gaskets	1/3 mo	Inspected replaced	Method 2.11 sec 6
Blower motor brushes	600-1000 hours	Replace	Method 2.11 sec 6
Manufacturer-Recommended Maintenance	per manufacturers' SOP	per manufacturers' SOP	
<b>SYSTEMATIC CRITERIA - PM<sub>10</sub> Continuous</b>			
Data Completeness	quarterly	$\geq$ 75%	Part 50 App. K, sec. 2.3
Reporting Units	all filters	$\mu\text{g}/\text{m}^3$ at standard temperature and pressure (STP)	Part 50 App K
Rounding Convention			



<b>Criteria</b>	<b>Frequency</b>	<b>Acceptable Range</b>	<b>Information (CFR or Method 2.11)</b>
24-hour, 3-year average	quarterly	nearest 10 $\mu\text{g}/\text{m}^3$ ( $\geq 5$ round up)	Part 50 App K sec 1
<b>Verification/Calibration Standards and Recertifications - All standards should have multi-point certifications against NIST Traceable standards</b>			
Flow Rate Transfer Std.	1/yr	$\pm 2\%$ of NIST-traceable Std.	Part 50, App.J sec 7.3
Field Thermometer	1/yr	$\pm 0.1^\circ\text{C}$ resolution, $\pm 0.5^\circ\text{C}$ accuracy	recommendation
Field Barometer	1/yr	$\pm 1\text{ mm Hg}$ resolution, $\pm 5\text{ mm Hg}$ accuracy	recommendation
<b>Calibration &amp; Check Standards</b>			
Flow Rate Transfer Std.	1/yr	$\pm 2\%$ of NIST-traceable Std.	Method 2.10 sec 9
<b>Verification/Calibration</b>			
Clock/timer Verification	4/year	5 min/mo	recommendation

**Pb High Volume (TSP) Validation Template**

**Note:** in 2008, the NAAQS was lowered for Pb and new monitoring rules were promulgated which allowed for the use of federal equivalent analytical methods and the use of PM<sub>10</sub> sampling in certain circumstances. The following information is guidance based on the current FRM which is sampling by TSP and analysis by atomic absorption. Information in this table is derived from the TSP sampling method in 40 CFR Part 50 App B, and QA Handbook Method 2.2 (1977). The analytical requirements/guidance is derived from 40 CFR Part 50, App G and QA Handbook Method 2.8 (1981). Monitoring for Pb based on the new NAAQS requirements will begin in calendar year 2010. **In 2009, new guidance related to analytical FEM (ICP-MS, XRF, etc.) will be developed and included as additional guidance for Pb. Revised and/or additional Pb validation templates will be included in this section and posted on AMTIC.**

Criteria	Frequency	Acceptable Range	Information (CFR or Method 2.2 or 2.8)
<b>CRITICAL CRITERIA- Pb in TSP</b>			
<b>Filter Holding Times</b>			
Sample Recovery	all filters	ASAP	Part 50 App B
<b>Sampling Period</b>	all filters	1440 minutes ± 60 minutes midnight to midnight	Part 50 App B sec 8.15
<b>Sampling Instrument</b>			
Average Flow Rate	every 24 hours of op	1.1-1.70 m <sup>3</sup> /min (varies with instrument)	Part 50 App B sec 8.8
<b>Filter</b>			Part 50 App B sec 7.1
Visual Defect Check (unexposed)	all filters	see reference	Part 50 App B sec 8.2
Collection Efficiency	all filters	99 %	Part 50 App B sec 7.1.4
Pressure Drop Range	all filters	42-54 mm Hg	Part 50 App B sec 7.1.5
pH	all filters	6-10	Part 50, App B sec 7.1.6
Pb Content	all filters pre-sampling batch check	<75 µg/filter	Part 50, App G sec 6.1.1 Method 2.8 sec 6.2.1
<b>Verification/Calibration</b>			
One-point Flow Rate Verification	1/3 mo	±7% from design transfer standard ±10% from design	Part 58 App A Method 2.2 sec 2.6
Calibration Reproducibility Checks	Beginning, every 10 samples and end	± 5% of value predicted by calibration curve	Part 50, App G Sec 9.3
Reagent Blank	Every analytical batch	< LDL	recomendation
Daily Calibration	Daily	until good agreement is obtained among replicates	Method 2.8 sec 2.8.5
<b>OPERATIONAL EVALUATIONS TABLE Pb in TSP</b>			
<b>Verification/Calibration</b>			
System Leak Check	During precalibration check	Auditory inspection with faceplate blocked	Method 2.2 sec 2.0

Criteria	Frequency	Acceptable Range	Information (CFR or Method 2.2 or 2.8)
FR Multi-point Verification/Calibration	After receipt, after motor maintenance or failure of 1-point check and 1/yr	5 points over range of 1.1 to 1.7 m <sup>3</sup> /min within ± 5% limits of linearity	Method 2.2 sec 2.6
<b>Precision</b>			
Collocated Samples	15% of each method code in PQAQ Frequency - every 12 days	CV ≤ 20% of samples > 0.02 μg/m <sup>3</sup> (cutoff value)	Part 58 App A sec 3.2.5
<b>Audits</b>			
Semi Annual Flow Rate Audit	2/yr	± 10% of audit standard and design value	Part 58, App A, sec 3.3.3
Lead Strip Analysis	6 strips/quarter 3/conc.	10% (percent difference)	Part 58, App A, sec 3.3.3
<b>Blanks</b>			
Field Filter Blank	1/quarter	< LDL	recommendation
<b>Monitor Maintenance</b>			
Inlet cleaning	1/3 mo	cleaned	recommendation
Motor/housing gaskets	~400 hours	Inspected replaced	Method 2.2 sec 7
Blower motor brushes	400-500	Replace	Method 2.2 sec 7
Manufacturer-Recommended Maintenance	per manufacturers' SOP	per manufacturers' SOP	NA
<b>SYSTEMATIC CRITERIA - Pb Filter Based Hi-Vol</b>			
<b>Data Completeness</b>	quarterly	three -month mean (i.e., the 3-month data capture rate) ≥ 75%	Part 50 App. R, sec. 4
<b>Reporting Units</b>	all filters	μg/m <sup>3</sup> at local temperature and pressure.	Part 50 App R
<b>Rounding Convention</b>			
3-month arithmetic mean	quarterly	Report data to 3 decimal places (data after 3 are truncated.	Part 50 App R
<b>Lower Detectable Limit</b>			
Atomic Absorption		0.07 μg/m <sup>3</sup>	Part 50 App G sec 2.3
<b>Verification/Calibration Standards and Recertifications - All standards should have multi-point certifications against NIST Traceable standards</b>			
Flow Rate Transfer Std.	1/yr	Resolution 0.02 m <sup>3</sup> /min ± 2% reproducibility	Part 50, App.B sec 7.8
Field Thermometer	1/yr	2° C resolution	Part 50, App.B sec 7.5
Field Barometer	1/yr	± 5 mm Hg resolution	Part 50, App.B sec 7.6
<b>Analytical Standards</b>			

<b>Criteria</b>	<b>Frequency</b>	<b>Acceptable Range</b>	<b>Information (CFR or Method 2.2 or 2.8)</b>
Reagents (HNO <sub>3</sub> and HCL)		ACS reagent grade	Part 50 App G sec.6.2
Pb nitrate Pb (NO <sub>3</sub> ) <sub>2</sub>		ACS reagent grade (99.0% purity)	Part 50 App G sec.6.2
<b>Verification/Calibration</b>			
Clock/timer Verification	4/year	5 min/mo	recommendation
<b>Precision</b>			
Single analyzer	1/3 mo.	Coefficient of variation (CV) ≤ 20%	recommendation
Single analyzer	1/ yr	CV ≤ 20%	recommendation
Primary Quality Assurance Org.	Annual and 3 year estimates	90% CL of CV ≤ 20%	Part 58, App A, sec 4.3.1
<b>Bias</b> Performance Evaluation Program (PEP)	5 audits for PQAOs with ≤ 5 sites 8 audits for PQAOs with > 5 sites	95% CL Absolute bias ±15%	Part 58, App A, Sec 2.3.1

SD= standard deviation

CV= coefficient of variation

## **Appendix E**

### **Characteristics of Spatial Scales Related to Each Pollutant**

The following tables provide information in order to match the spatial scale represented by the monitor with the monitoring objectives.

**NOTE: This information can also be found in 40 CFR Part 58, Appendix D and since there is a possibility that spatial scales have been updated, users should also review CFR.**

*Page intentionally left blank*

Pollutant	Spatial Scale	<b>Characteristics NOTE: This information can also be found in 40 CFR Part 58, Appendix D and since there is a possibility that spatial scales have been updated, users should also review CFR.</b>
NCore	Urban  Rural	<p>Generally located at urban or neighborhood scale to provide representative concentrations of exposure expected throughout the metropolitan area; however, a middle-scale site may be acceptable in cases where the site can represent many such locations throughout a metropolitan area.</p> <p>Rural NCore stations are to be located to the maximum extent practicable at a regional or larger scale away from any large local emission source, so that they represent ambient concentrations over an extensive area.</p>
PM <sub>10</sub>	Micro  Middle  Neighborhood	<p>This scale would typify areas such as downtown street canyons, traffic corridors, and fence line stationary source monitoring locations where the general public could be exposed to maximum PM<sub>10</sub> concentrations. Microscale particulate matter sites should be located near inhabited buildings or locations where the general public can be expected to be exposed to the concentration measured. Emissions from stationary sources such as primary and secondary smelters, power plants, and other large industrial processes may, under certain plume conditions, likewise result in high ground level concentrations at the microscale. In the latter case, the microscale would represent an area impacted by the plume with dimensions extending up to approximately 100 meters. Data collected at microscale sites provide information for evaluating and developing hot spot control measures.</p> <p>Much of the short-term public exposure to coarse fraction particles (PM<sub>10</sub>) is on this scale and on the neighborhood scale. People moving through downtown areas or living near major roadways or stationary sources, may encounter particulate pollution that would be adequately characterized by measurements of this spatial scale. Middle scale PM<sub>10</sub> measurements can be appropriate for the evaluation of possible short-term exposure public health effects. In many situations, monitoring sites that are representative of micro-scale or middle-scale impacts are not unique and are representative of many similar situations. This can occur along traffic corridors or other locations in a residential district. In this case, one location is representative of a neighborhood of small scale sites and is appropriate for evaluation of long-term or chronic effects. This scale also includes the characteristic concentrations for other areas with dimensions of a few hundred meters such as the parking lot and feeder streets associated with shopping centers, stadia, and office buildings. In the case of PM<sub>10</sub>, unpaved or seldomly swept parking lots associated with these sources could be an important source.</p> <p>Measurements in this category represent conditions throughout some reasonably homogeneous urban subregion with dimensions of a few kilometers and of generally more regular shape than the middle scale. Homogeneity refers to the particulate matter concentrations, as well as the land use and land surface characteristics. In some cases, a location carefully chosen to provide neighborhood scale data would represent not only the immediate neighborhood but also neighborhoods of the same type in other parts of the city. Neighborhood scale PM<sub>10</sub> sites provide information about trends and compliance with standards because they often represent conditions in areas where people commonly live and work for extended periods. Neighborhood scale data could provide valuable information for developing, testing, and revising models that describe the largerscale concentration patterns, especially those models relying on spatially smoothed emission fields for inputs. The neighborhood scale measurements could also be used for neighborhood comparisons within or between cities.</p>

Pollutant	Spatial Scale	Characteristics <b>NOTE: This information can also be found in 40 CFR Part 58, Appendix D and since there is a possibility that spatial scales have been updated, users should also review CFR.</b>
SO <sub>2</sub>	Micro/Middle  Neighborhood	Some data uses associated with microscale and middle scale measurements for SO <sub>2</sub> include assessing the effects of control strategies to reduce concentrations (especially for the 3-hour and 24-hour averaging times) and monitoring air pollution episodes.  This scale applies where there is a need to collect air quality data as part of an ongoing SO <sub>2</sub> stationary source impact investigation. Typical locations might include suburban areas adjacent to SO <sub>2</sub> stationary sources for example, or for determining background concentrations as part of these studies of population responses to exposure to SO <sub>2</sub> .
CO	Micro  Middle	This scale applies when air quality measurements are to be used to represent distributions within street canyons, over sidewalks, and near major roadways. In the case with carbon monoxide, microscale measurements in one location can often be considered as representative of other similar locations in a city.  Middle scale measurements are intended to represent areas with dimensions from 100 meters to 0.5 kilometer. In certain cases, middle scale measurements may apply to areas that have a total length of several kilometers, such as "line" emission source areas. This type of emission sources areas would include air quality along a commercially developed street or shopping plaza, freeway corridors, parking lots and feeder streets
O <sub>3</sub>	Neighborhood  Urban  Regional	Measurements in this category represent conditions throughout some reasonably homogeneous urban subregion, with dimensions of a few kilometers. Homogeneity refers to pollutant concentrations. Neighborhood scale data will provide valuable information for developing, testing, and revising concepts and models that describe urban/regional concentration patterns. These data will be useful to the understanding and definition of processes that take periods of hours to occur and hence involve considerable mixing and transport. Under stagnation conditions, a site located in the neighborhood scale may also experience peak concentration levels within a metropolitan area.  Measurement in this scale will be used to estimate concentrations over large portions of an urban area with dimensions of several kilometers to 50 or more kilometers. Such measurements will be used for determining trends, and designing area-wide control strategies. The urban scale sites would also be used to measure high concentrations downwind of the area having the highest precursor emissions.  This scale of measurement will be used to typify concentrations over large portions of a metropolitan area and even larger areas with dimensions of as much as hundreds of kilometers. Such measurements will be useful for assessing the O <sub>3</sub> that is transported to and from a metropolitan area, as well as background concentrations. In some situations, particularly when considering very large metropolitan areas with complex source mixtures, regional scale sites can be the maximum concentration location.



Pollutant	Spatial Scale	<b>Characteristics NOTE: This information can also be found in 40 CFR Part 58, Appendix D and since there is a possibility that spatial scales have been updated, users should also review CFR.</b>
NO <sub>2</sub>	Middle Neighborhood Urban	Dimensions from about 100 meters to 0.5 kilometer. These measurements would characterize the public exposure to NO <sub>2</sub> in populated areas. Same as for O <sub>3</sub> Same as for O <sub>3</sub>

Pollutant	Spatial Scale	<b>Characteristics NOTE: This information can also be found in 40 CFR Part 58, Appendix D and since there is a possibility that spatial scales have been updated, users should also review CFR.</b>
PM2.5	<p>Microscale</p> <p>Middle</p> <p>Neighborhood</p> <p>Urban</p> <p>Regional</p>	<p>Areas such as downtown street canyons and traffic corridors where the general public would be exposed to maximum concentrations from mobile sources. In some circumstances, the microscale is appropriate for particulate sites; community-oriented SLAMS sites measured at the microscale level should, however, be limited to urban sites that are representative of long-term human exposure and of many such microenvironments in the area. In general, microscale particulate matter sites should be located near inhabited buildings or locations where the general public can be expected to be exposed to the concentration measured. Emissions from stationary sources such as primary and secondary smelters, power plants, and other large industrial processes may, under certain plume conditions, likewise result in high ground level concentrations at the microscale. In the latter case, the microscale would represent an area impacted by the plume with dimensions extending up to approximately 100 meters. Data collected at microscale sites provide information for evaluating and developing hot spot control measures.</p> <p>People moving through downtown areas, or living near major roadways, encounter particle concentrations that would be adequately characterized by this spatial scale. Thus, measurements of this type would be appropriate for the evaluation of possible short-term exposure public health effects of particulate matter pollution. In many situations, monitoring sites that are representative of microscale or middle-scale impacts are not unique and are representative of many similar situations. This can occur along traffic corridors or other locations in a residential district. In this case, one location is representative of a number of small scale sites and is appropriate for evaluation of long-term or chronic effects. This scale also includes the characteristic concentrations for other areas with dimensions of a few hundred meters such as the parking lot and feeder streets associated with shopping centers, stadia, and office buildings.</p> <p>Measurements in this category would represent conditions throughout some reasonably homogeneous urban sub-region with dimensions of a few kilometers and of generally more regular shape than the middle scale. Homogeneity refers to the particulate matter concentrations, as well as the land use and land surface characteristics. Much of the PM2.5 exposures are expected to be associated with this scale of measurement. In some cases, a location carefully chosen to provide neighborhood scale data would represent the immediate neighborhood as well as neighborhoods of the same type in other parts of the city. PM2.5 sites of this kind provide good information about trends and compliance with standards because they often represent conditions in areas where people commonly live and work for periods comparable to those specified in the NAAQS. In general, most PM2.5 monitoring in urban areas should have this scale.</p> <p>This class of measurement would be used to characterize the particulate matter concentration over an entire metropolitan or rural area ranging in size from 4 to 50 kilometers. Such measurements would be useful for assessing trends in area-wide air quality, and hence, the effectiveness of large scale air pollution control strategies. Community-oriented PM2.5 sites may have this scale.</p> <p>These measurements would characterize conditions over areas with dimensions of as much as hundreds of kilometers. As noted earlier, using representative conditions for an area implies some degree of homogeneity in that area. For this reason, regional scale measurements would be most applicable to sparsely populated areas. Data characteristics of this scale would provide information about larger scale processes of particulate matter.</p>

Pollutant	Spatial Scale	<b>Characteristics NOTE: This information can also be found in 40 CFR Part 58, Appendix D and since there is a possibility that spatial scales have been updated, users should also review CFR.</b>
Pb	Micro	This scale would typify areas in close proximity to lead point sources. Emissions from point sources such as primary and secondary lead smelters, and primary copper smelters may under fumigation conditions likewise result in high ground level concentrations at the microscale. In the latter case, the microscale would represent an area impacted by the plume with dimensions extending up to approximately 100 meters. Data collected at microscale sites provide information for evaluating and developing “hot-spot” control measures.
	Middle	This scale generally represents Pb air quality levels in areas up to several city blocks in size with dimensions on the order of approximately 100 meters to 500 meters. The middle scale may for example, include schools and playgrounds in center city areas which are close to major Pb point sources. Pb monitors in such areas are desirable because of the higher sensitivity of children to exposures of elevated Pb concentrations (reference 3 of this appendix). Emissions from point sources frequently impact on areas at which single sites may be located to measure concentrations representing middle spatial scales.
	Neighborhood	The neighborhood scale would characterize air quality conditions throughout some relatively uniform land use areas with dimensions in the 0.5 to 4.0 kilometer range. Sites of this scale would provide monitoring data in areas representing conditions where children live and play. Monitoring in such areas is important since this segment of the population is more susceptible to the effects of Pb. Where a neighborhood site is located away from immediate Pb sources, the site may be very useful in representing typical air quality values for a larger residential area, and therefore suitable for population exposure and trends analyses.
PAMs	Neighborhood	Would define conditions within some extended areas of the city that have a relatively uniform land use and range from 0.5 to 4 km. Measurements on a neighborhood scale represent conditions throughout a homogeneous urban subregion. Precursor concentrations, on this scale of a few kilometers, will become well mixed and can be used to assess exposure impacts and track emissions. Neighborhood data will provide information on pollutants relative to residential and local business districts. VOC sampling at Site #2 is characteristic of a neighborhood scale. Measurements of these reactants are ideally located just downwind of the edge of the urban core emission areas. Further definition of neighborhood and urban scales is provided in Appendix D of 40 CFR 58 and Reference 9.
	Urban	Would represent concentration distributions over a metropolitan area. Monitoring on this scale relates to precursor emission distributions and control strategy plans for an MSA/CMSA. PAMS Sites #1, #3, and #4 are characteristic of the urban scale.

Pollutant	Spatial Scale	Characteristics <b>NOTE: This information can also be found in 40 CFR Part 58, Appendix D and since there is a possibility that spatial scales have been updated, users should also review CFR.</b>
PM <sub>10-2.5</sub>	<p>Micro</p> <p>Middle</p> <p>Neighborhood</p>	<p>The only required monitors for PM<sub>10-2.5</sub> are those required at NCore Stations. Although microscale monitoring may be appropriate in some circumstances, middle and neighborhood scale measurements are the most important station classifications for PM<sub>10-2.5</sub></p> <p>This scale would typify relatively small areas immediately adjacent to: Industrial sources; locations experiencing ongoing construction, redevelopment, and soil disturbance; and heavily traveled roadways. Data collected at microscale stations would characterize exposure over areas of limited spatial extent and population exposure, and may provide information useful for evaluating and developing source oriented control measures.</p> <p>People living or working near major roadways or industrial districts encounter particle concentrations that would be adequately characterized by this spatial scale. Thus, measurements of this type would be appropriate for the evaluation of public health effects of coarse particle exposure. Monitors located in populated areas that are nearly adjacent to large industrial point sources of coarse particles provide suitable locations for assessing maximum population exposure levels and identifying areas of potentially poor air quality. Similarly, monitors located in populated areas that border dense networks of heavily-traveled traffic are appropriate for assessing the impacts of resuspended road dust. This scale also includes the characteristic concentrations for other areas with dimensions of a few hundred meters such as school grounds and parks that are nearly adjacent to major roadways and industrial point sources, locations exhibiting mixed residential and commercial development, and downtown areas featuring office buildings, shopping centers, and stadiums.</p> <p>Measurements in this category would represent conditions throughout some reasonably homogeneous urban sub-region with dimensions of a few kilometers and of generally more regular shape than the middle scale. Homogeneity refers to the particulate matter concentrations, as well as the land use and land surface characteristics. This category includes suburban neighborhoods dominated by residences that are somewhat distant from major roadways and industrial districts but still impacted by urban sources, and areas of diverse land use where residences are interspersed with commercial and industrial neighborhoods. In some cases, a location carefully chosen to provide neighborhood scale data would represent the immediate neighborhood as well as neighborhoods of the same type in other parts of the city. The comparison of data from middle scale and neighborhood scale sites would provide valuable information for determining the variation of PM<sub>10-2.5</sub> levels across urban areas and assessing the spatial extent of elevated concentrations caused by major industrial point sources and heavily traveled roadways. Neighborhood scale sites would provide concentration data that are relevant to informing a large segment of the population of their exposure levels on a given day.</p>
PM <sub>2.5</sub> Speciation	NA	Each State shall continue to conduct chemical speciation monitoring and analyses at sites designated to be part of the PM <sub>2.5</sub> Speciation Trends Network (STN). The selection and modification of these STN sites must be approved by the Administrator.

## **Appendix F**

### **Sample Manifold Design for Precursor Gas Monitoring**

The following information is extracted from the document titled: *Version 4 of the Technical Assistance Document for Precursor Gas Measurements in the NCore Multi-pollutant Monitoring Network* which can be found on the AMTIC website at: <http://www.epa.gov/ttn/amtic/pretecdoc.html>

*Page intentionally left blank*

## Sample Manifold Design for Precursor Gas Monitoring

Many important variables affect sampling manifold design for ambient precursor gas monitoring: residence time of sample gases, materials of construction, diameter, length, flow rate, and pressure drop. Considerations for these parameters are discussed below.

**Residence Time Determination:** The residence time of air pollutants within the sampling system (defined as extending from the entrance of the sample inlet above the instrument shelter to the bulkhead of the precursor gas analyzer) is critical. Residence time is defined as the amount of time that it takes for a sample of air to travel through the sampling system. This issue is discussed in detail for NO<sub>y</sub> monitoring in Section 4.2, and recommendations in Section 4 for the arrangement of the molybdenum converter and inlet system should be followed. However, residence time is also an issue for other precursor gases, and should be considered in designing sample manifolds for those species. For example, Code of Federal Regulations (CFR), Title 40 Part 58, Appendix E.9 states, "Ozone in the presence of NO will show significant losses even in the most inert probe material when the residence time exceeds 20 seconds. Other studies indicate that 10-second or less residence time is easily achievable."<sup>1</sup> Although 20-second residence time is the maximum allowed as specified in 40 CFR 58, Appendix E, it is recommended that the residence time within the sampling system be less than 10 seconds. If the volume of the sampling system does not allow this to occur, then a blower motor or other device (such as a vacuum pump) can be used to increase flow rate and decrease the residence time. The residence time for a sample manifold system is determined in the following way. First the total volume of the cane (inlet), manifold, and sample lines must be determined using the following equation:

$$\text{Total Volume} = C_v + M_v + L_v \quad \text{Equation 1}$$

Where:

$C_v$  = Volume of the sample cane or inlet and extensions

$M_v$  = Volume of the sample manifold and moisture trap

$L_v$  = Volume of the instrument lines from the manifold to the instrument bulkhead

The volume of each component of the sampling system must be measured individually. To measure the volume of the components (assuming they are cylindrical in shape), use the following equation:

$$V = \pi * (d/2)^2 * L \quad \text{Equation 2}$$

Where:

$V$  = volume of the component, cm<sup>3</sup>

$\pi$  = 3.14

$L$  = Length of the component, cm

$d$  = inside diameter of the component, cm

Once the total volume is determined, divide the total volume by the total sample flow rate of all instruments to calculate the residence time in the inlet. If the residence time is greater than 20 seconds, attach a blower or vacuum pump to increase the flow rate and decrease the residence time.

**Laminar Flow Manifolds:** In the past, vertical laminar flow manifolds were a popular design. By the proper selection of a large diameter vertical inlet probe and by maintaining a laminar flow throughout, it was assumed that the sample air would not react with the walls of the probe. Numerous materials such as glass, plastic, galvanized steel, and stainless steel were used for constructing the probe. Removable sample lines constructed of FEP or PTFE were placed to protrude into the manifold to provide each instrument with sample air. A laminar flow manifold could have a flow rate as high as 150 L/min, in order to minimize any losses, and large diameter tubing was used to minimize pressure drops. However, experience has shown that vertical laminar flow manifolds have demonstrated many disadvantages which are listed below:

- Since the flow rates are so high, it is difficult to supply enough audit gas to provide an adequate independent assessment for the entire sampling system;
- Long laminar flow manifolds may be difficult to clean due to size and length;
- Temperature differentials may exist that could change the characteristics of the gases, e.g., if a laminar manifold's inlet is on top of a building, the temperature at the bottom of the building may be much lower, thereby dropping the dew point and condensing water.
- Construction of the manifold is frequently of an unapproved material.

For these technical reasons, EPA strongly discourages the use of laminar flow manifolds in the national air monitoring network. It is recommended that agencies that utilize laminar manifolds migrate to conventional manifold designs that are described below.

**Sampling Lines as Inlet and Manifold:** Often air monitoring agencies will place individual sample lines outside of their shelter for each instrument. If the sample lines are manufactured out of Polytetrafluoroethylene (PTFE) or Fluoroethylpropylene (FEP) Teflon®, this is acceptable to the EPA. The advantages to using single sample lines are: no breakage and ease of external auditing. In addition, rather than cleaning glass manifolds, some agencies just replace the sampling lines. However, please note the following caveats:

1. PTFE and FEP lines can deteriorate when exposed to atmospheric conditions, particularly ultraviolet radiation from the sun. Therefore, it is recommended that sample lines be inspected and replaced regularly.
2. Small insects and particles can accumulate inside of the tubing. It has been reported that small spiders build their webs inside of tubing. This can cause blockage and affect the response of the instruments. In addition, particles can collect inside the tubing, especially at the entrance, thus affecting precursor gas concentrations. Check the sampling lines and replace or clean the tubing on a regular basis.
3. Since there is no central manifold, these configurations sometimes have a “three-way” tee, i.e., one flow path for supplying calibration mixtures and the other for the sampling of ambient air. If the three-way tee is not placed near the outermost limit of the sample inlet



tubing, then the entire sampling system is not challenged by the provision of calibration gas. It is strongly recommended that at least on a periodic basis calibration gas be supplied so that it floods the entire sample line. This is best done by placing the three-way tee just below the sample inlet, so that calibration gas supplied there is drawn through the entire sampling line.

4. The calibration gas must be delivered to the analyzers at near ambient pressure. Some instruments are very sensitive to pressure changes. If the calibration gas flow is excessive, the analyzer may sample the gas under pressure. If a pressure effect on calibration gas response is suspected, it is recommended that the gas be introduced at more than one place in the sampling line (by placement of the tee, as described in item #3 above). If the response to the calibration gas is the same regardless of delivery point, then there is likely no pressure effect.

**Conventional Manifold Design** - A number of “conventional” manifold systems exist today. However, one manifold feature must be consistent: the probe and manifold must be constructed of borosilicate glass or Teflon® (PFA or PTFE). These are the only materials proven to be inert to gases. EPA will accept manifolds or inlets that are made from other materials, such as steel or aluminum, that are lined or coated with borosilicate glass or the Teflon® materials named above. However, all of the linings, joints and connectors that could possibly come into contact with the sample gases must be of glass or Teflon®. It is recommended that probes and manifolds be constructed in modular sections to enable frequent cleaning. It has been demonstrated that there are no significant losses of reactive gas concentrations in conventional 13 mm inside diameter (ID) sampling lines of glass or Teflon® if the sample residence time is 10 seconds or less. This is true even in sample lines up to 38 m in length. However, when the sample residence time exceeds 20 seconds, loss is detectable, and at 60 seconds the loss can be nearly complete. Therefore, EPA requires that residence times must be 20 seconds or less (except for NO<sub>y</sub>). Please note that for particulate matter (PM) monitoring instruments, such as nephelometers, Tapered Element Oscillating Microbalance (TEOM) instruments, or Beta Gauges, the ambient precursor gas manifold is not recommended. Particle monitoring instruments should have separate intake probes that are as short and as straight as possible to avoid particulate losses due to impaction on the walls of the probe.

**T-Type Design:** The most popular gas sampling system in use today consists of a vertical “candy cane” protruding through the roof of the shelter with a horizontal sampling manifold connected by a tee fitting to the vertical section (Figure 1). This type of manifold is commercially available. At the bottom of the tee is a bottle for collecting particles and moisture that cannot make the bend; this is known as the “drop out” or moisture trap bottle. Please note that a small blower at the exhaust end of the system (optional) is used to provide flow through the sampling system. There are several issues that must be mitigated with this design:

- The probe and manifold may have a volume such that the total draw of the precursor gas analyzers cannot keep the residence time less than 20 seconds (except NO<sub>y</sub>), thereby requiring a blower motor. However, a blower motor may prevent calibration and audit gases from being supplied in sufficient quantity, because of the high flow rate in the manifold. To remedy this, the blower motor must be turned off for calibration.

However, this may affect the response of the instruments since they are usually operated with the blower on.

- Horizontal manifolds have been known to collect water, especially in humid climates. Standing water in the manifold can be pulled into the instrument lines. Since most monitoring shelters are maintained at 20-30 °C, condensation can occur when warm humid outside air enters the manifold and is cooled. Station operators must be aware of this issue and mitigate this situation if it occurs. Tilting the horizontal manifold slightly and possibly heating the manifold have been used to mitigate the condensation problem. Water traps should be emptied whenever there is standing water.

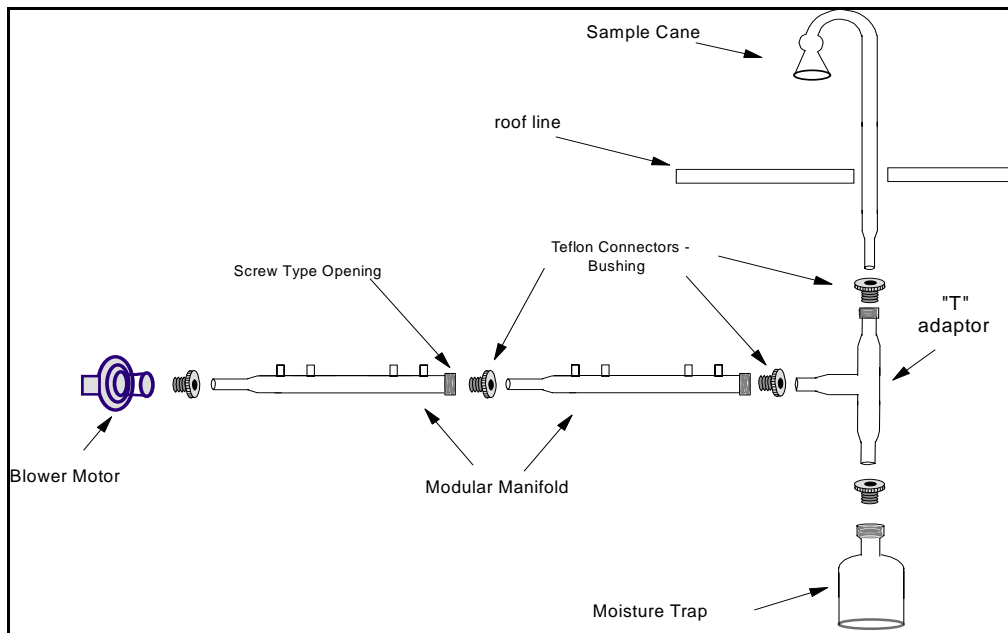

**Figure 1. Conventional T-Type Glass Manifold System**

**California Air Resources Board “Octopus” Style:** Another type of manifold that is being widely used is known as the California Air Resources Board (CARB) style or “Octopus” manifold, illustrated in Figure 2. This manifold has a reduced profile, i.e., there is less volume in the cane and manifold; therefore, there is less need for a blower motor. If the combined flow rates of the gas analyzers are high enough, then an additional blower is not required.

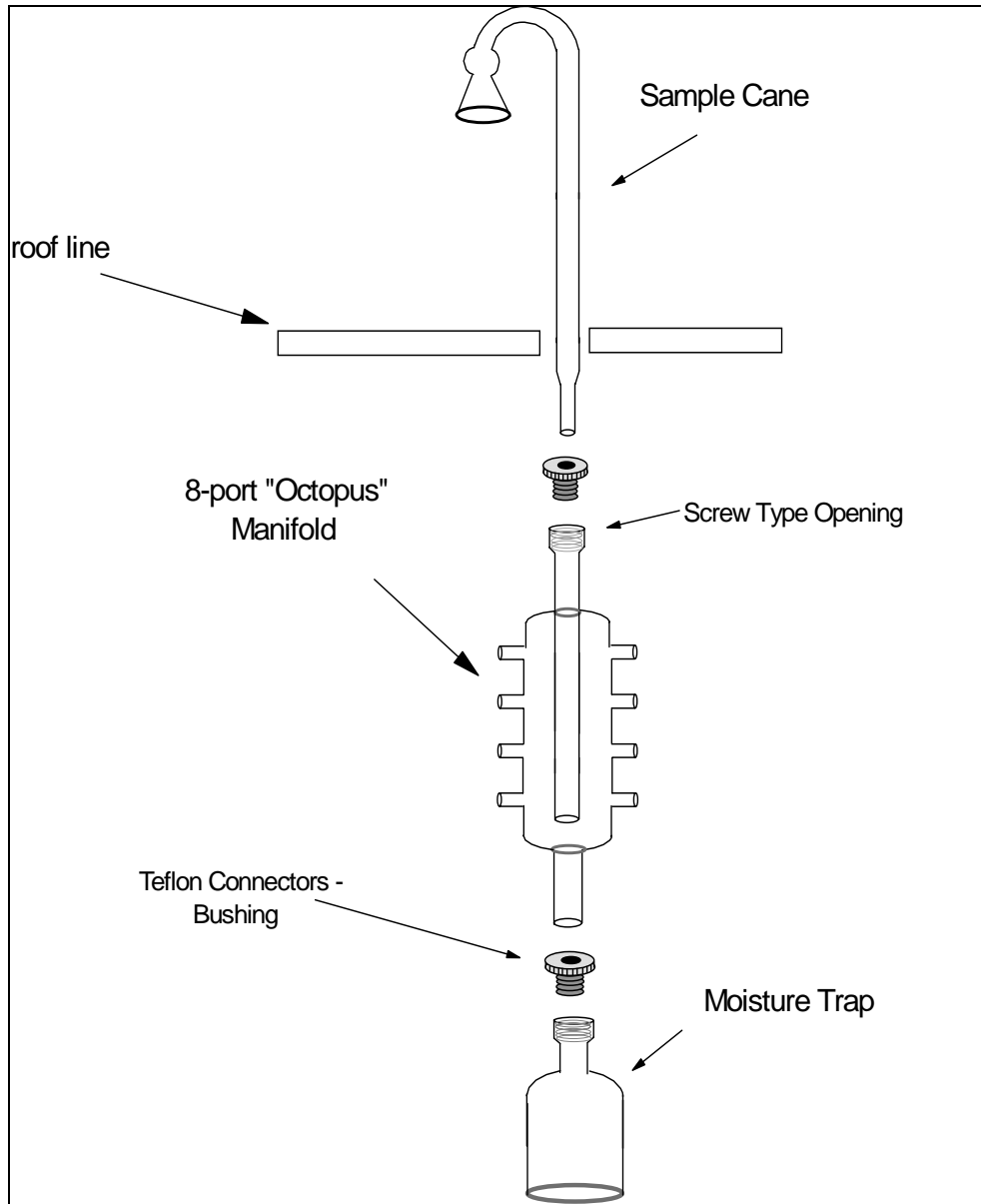

**Figure 2. CARB or “Octopus” Style Manifold**

**Placement of Tubing on the Manifold:** If the manifold employed at the station has multiple ports (as in Figure 2) then the position of the instrument lines relative to the calibration input line can be crucial. If a CARB “Octopus” or similar manifold is used, it is suggested that sample connections for analyzers requiring lower flows be placed towards the bottom of the manifold. Also, the general rule of thumb states that the calibration gas delivery line (if used) should be in a location so that the calibration gas flows past the analyzer inlet points before the gas is evacuated out of the manifold. Figure 3 illustrates two potential locations for introduction of the calibration gas. One is located at the ports on the “Octopus” manifold, and the other is upstream near the air inlet point, using an audit or probe inlet stub. This stub is a tee fitting placed so that “Through-the-Probe” audit line or sampling system tests and calibrations can be conducted.

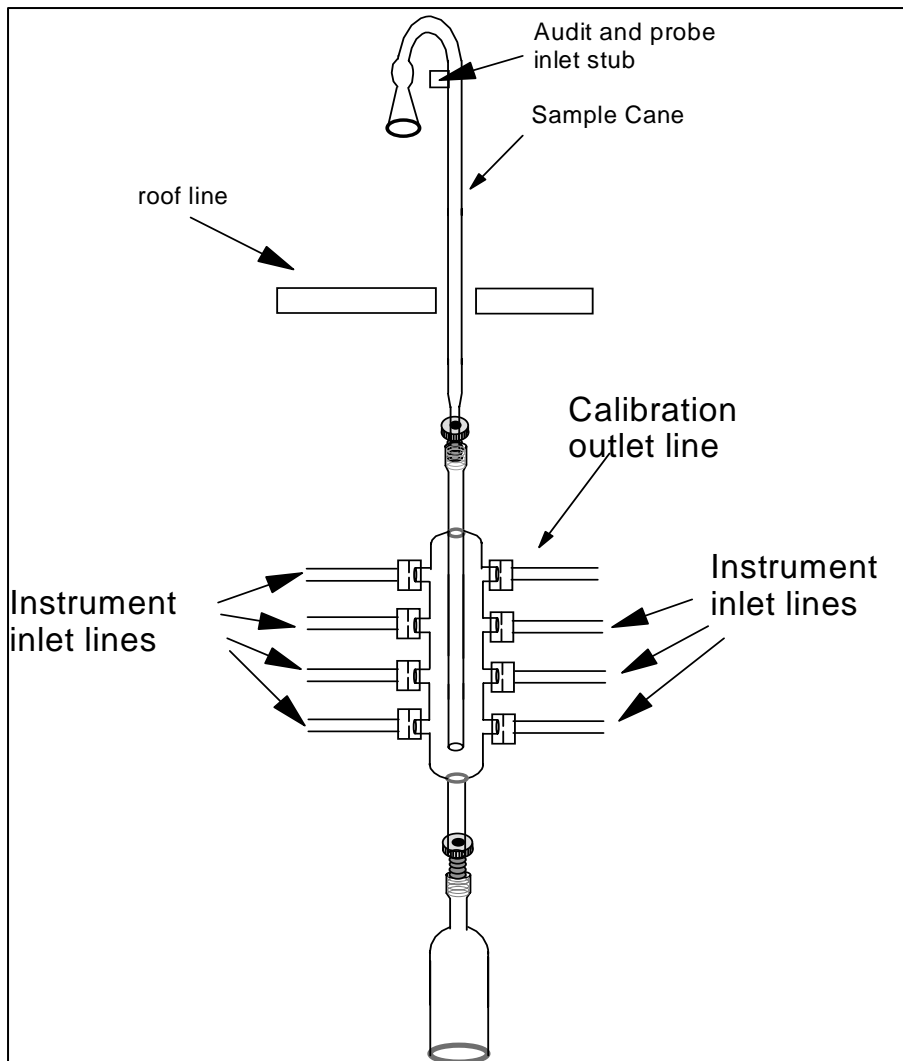
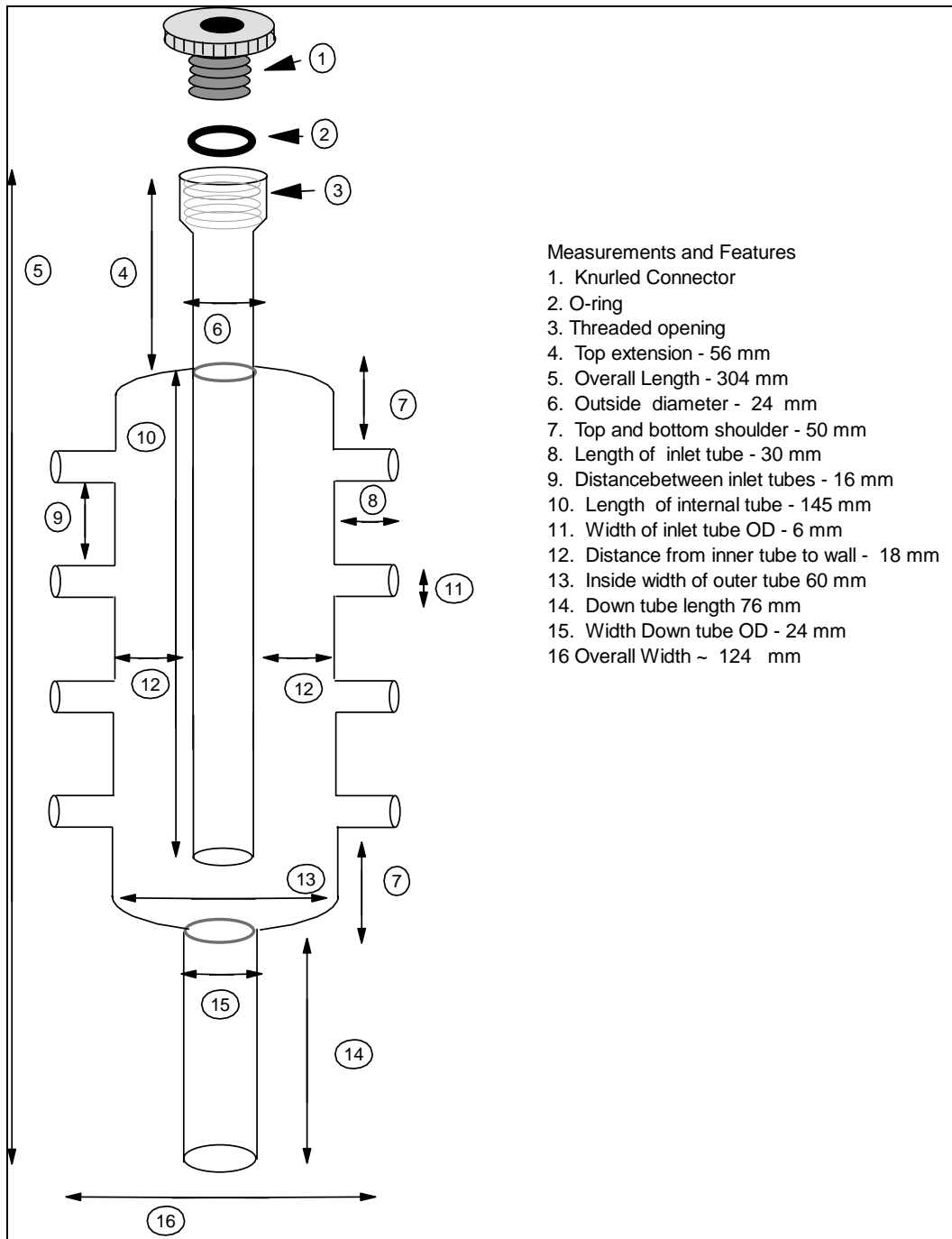

Figure 3. Placement of Lines on the Manifold



**Figure 4. Specifications for an 'Octopus' Style Manifold**

Figure 4 illustrates the specifications of an Octopus style manifold. Please note that EPA-OAQPS has used this style of manifold in its precursor gas analyzer testing program. This type of manifold is commercially available.

**Vertical Manifold Design:** Figure 5 shows a schematic of the vertical manifold design. Commercially available vertical manifolds have been on the market for some time. The issues with this type of manifold are the same with other conventional manifolds, i.e., when sample air moves from a warm humid atmosphere into an air-conditioned shelter, condensation of moisture can occur on the walls of the manifold. Commercially available vertical manifolds have the option for heated insulation to mitigate this problem. Whether the manifold tubing is made of glass or Teflon®, the heated insulation prevents viewing of the tubing, so the interior must be inspected often. The same issues apply to this manifold style as with horizontal or “Octopus” style manifolds: additional blower motors should not be used if the residence time is less than 20 seconds, and the calibration gas inlet should be placed upstream so that the calibration gas flows past the analyzer inlets before it exits the manifold.

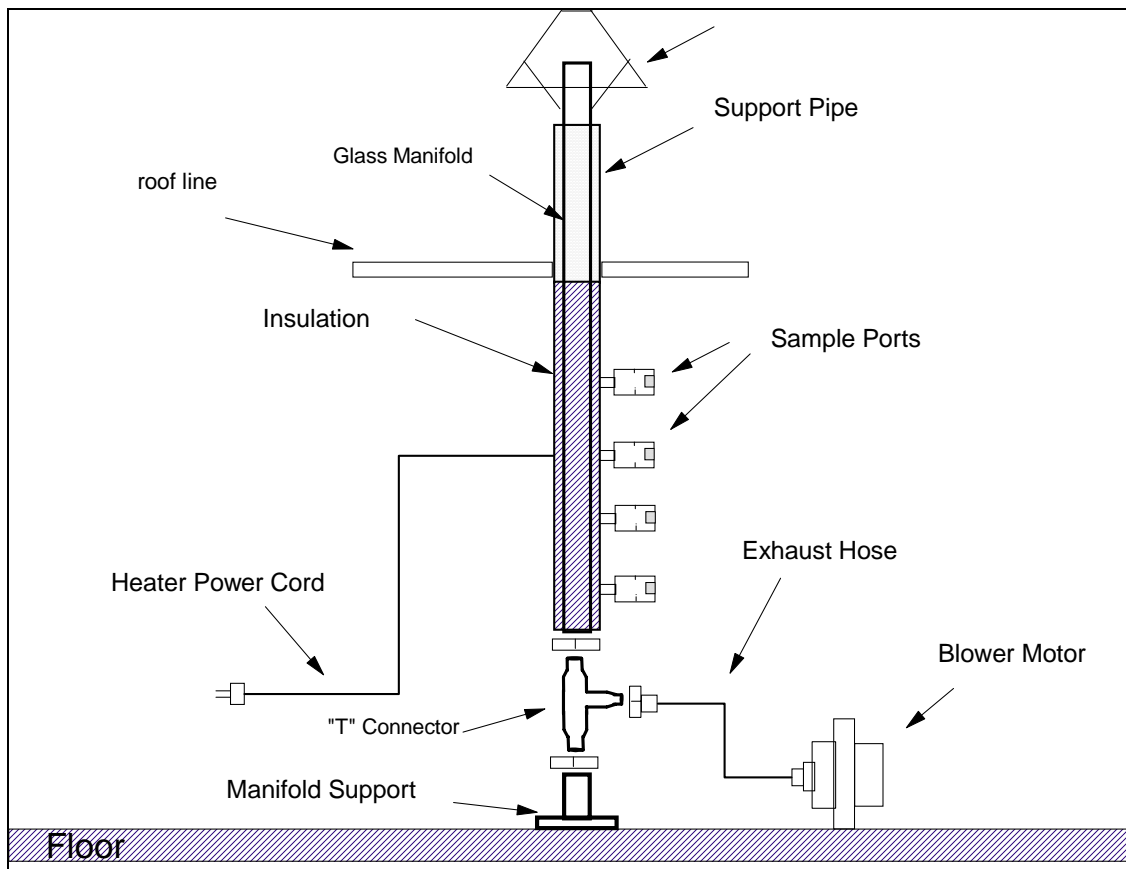
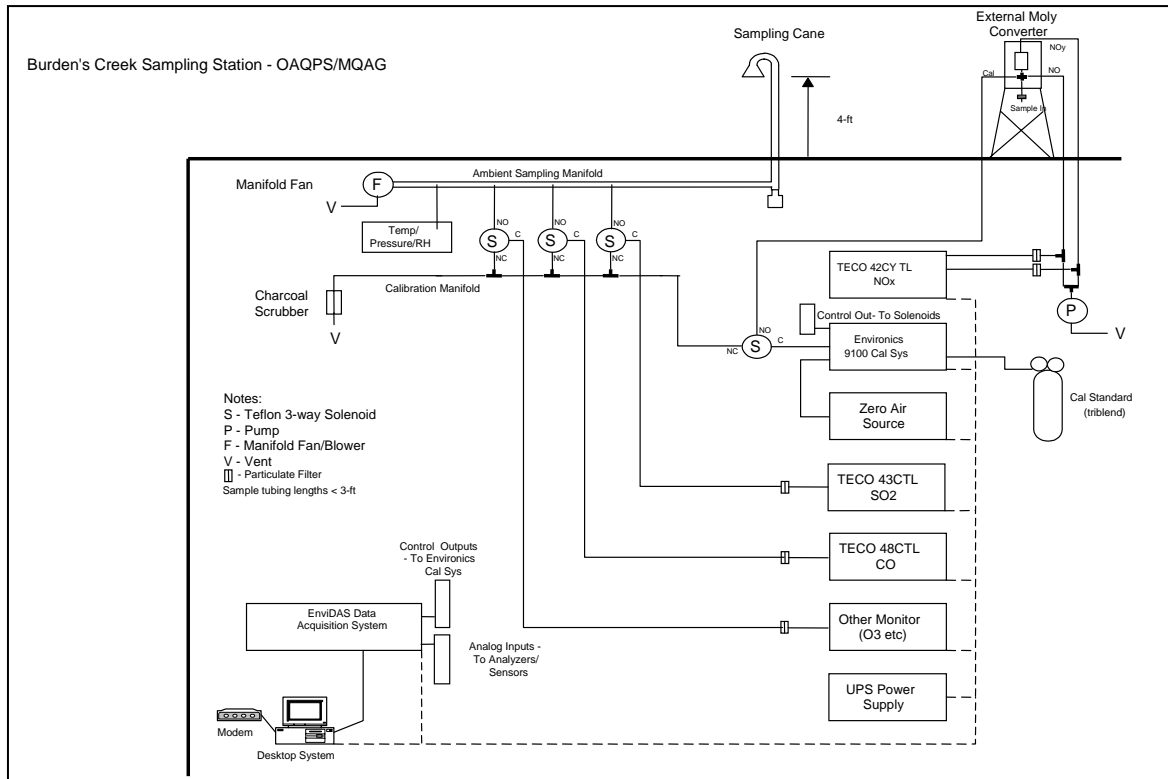

**Figure 5. Example of Vertical Design Manifold**

**Manifold/Instrument Line Interface:** A sampling system is an integral part of a monitoring station, however, it is only one part of the whole monitoring process. With the continuing integration of advanced electronics into monitoring stations, manifold design must be taken into consideration. Data Acquisition Systems (DASs) are able not only to collect serial and analog data from the analyzers, but also to control Mass Flow Calibration (MFC) equipment and solid state solenoid switches, communicate via modem or Ethernet, and monitor conditions such as shelter temperature and manifold pressure. As described in Chapter 6, commercially available DASs may implement these features in an electronic data logger, or via software installed on a personal computer. Utilization of these features allows the DAS and support equipment to perform automated calibrations (Autocal). In addition to performing these tasks, the DAS can flag data during calibration periods and allow the data to be stored in separate files that can be reviewed remotely.

Figure 6 shows a schematic of the integrated monitoring system at EPA's Burden Creek NCore monitoring station. Note that a series of solenoid switches are positioned between the ambient air inlet manifold and an additional "calibration" manifold. This configuration allows the DAS to control the route from which the analyzers draw their sample. At the beginning of an Autocal, the DAS signals the MFC unit to come out of standby mode and start producing zero or calibration gas. Once the MFC has stabilized, the DAS switches the analyzers' inlet flow (via solenoids) from the ambient air manifold to the calibration manifold. The calibration gas is routed to the instruments, and the DAS monitors and averages the response, flagging the data appropriately as calibration data. When the Autocal has terminated, the DAS switches the analyzers' inlet flow from the calibration manifold back to the ambient manifold, and the data system resets the data flag to the normal ambient mode.

The integration of DAS, solenoid switches, and MFC into an automated configuration can bring an additional level of complexity to the monitoring station. Operators must be aware that this additional complexity can create situations where leaks can occur. For instance, if a solenoid switch fails to open, then the inlet flow of an analyzer may not be switched back to the ambient manifold, but instead will be sampling interior room air. When the calibrations occur, the instrument will span correctly, but will not return to ambient air sampling. In this case, the data collected must be invalidated. These problems are usually not discovered until there is an external "Through-the Probe" audit, but by then extensive data could be lost. It is recommended that the operator remove the calibration line from the calibration manifold on a routine basis and challenge the sampling system from the inlet probe. This test will discover any leak or switching problems within the entire sampling system.



**Figure 6. Example of a Manifold/Instrument Interface**

Figure 7 shows a close up of an ambient/calibration manifold, illustrating the calibration manifold – ambient manifold interface. This is the same interface used at EPA’s Burden’s Creek monitoring station. The interface consists of three distinct portions: the ambient manifold, the solenoid switching system and the calibration manifold. In this instance, the ambient manifold is a T-type design that is being utilized with a blower fan at the terminal. Teflon® tubing connects the manifold to the solenoid switching system. Two-way solenoids have two configurations. Either the solenoid is in its passive state, at which time the ports that are connected are the normally open (NO) and the common (COM). In the other state, when it is energized, the ports that are connected are the normally closed (NC) and the COM ports. Depending on whether the solenoid is ‘active’ or not, the solenoid routes the air from the calibration or ambient manifold to the instrument inlets. There are two configurations that can be instituted with this system.

1. Ambient Mode: In this mode the solenoids are in “passive” state. The flow of air (under vacuum) is routed from the NO port through the solenoid to the COM port.
2. Calibration Mode: In this mode, the solenoids are in the “active” state. An external switching device, usually the DAS, must supply direct current to the solenoid. This causes the solenoid to be energized so that the NO port is shut and the NC port is now connected to the COM port. As in all cases, the COM port is always selected. The switching of the solenoid is done in conjunction with the MFC unit becoming active;



generally, the MFC is controlled by the DAS. When the calibration sequences have finished, the DAS stops the direct current from being sent to the solenoid and switches automatically back to the NO to COM (inactive) port configuration. This allows the air to flow through the NO to COM port and the instrument is now back on ambient mode.

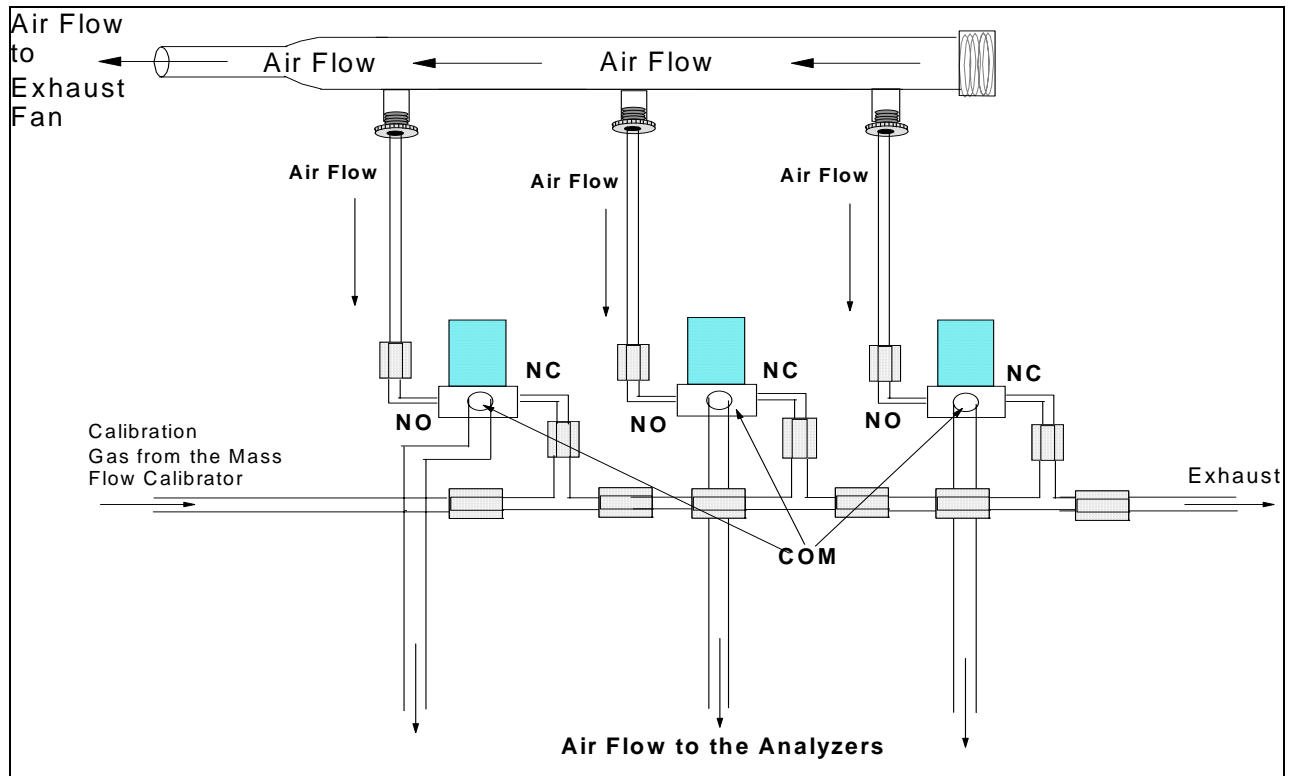

**Figure 7. Ambient – Calibration Manifold Interface**

## Reference

1. Code of Federal Regulations, Title 40, Part 58, Appendix E.9

## **Appendix G**

### **Example Procedure for Calibrating a Data Acquisition System**

*This page left blank intentionally*

## DAS Calibration Technique

The following is an example of a DAS calibration. The DAS owner's manual should be followed. The calibration of a DAS is performed by inputting known voltages into the DAS and measuring the output of the DAS.

1. The calibration begins by obtaining a voltage source and an ohm/voltmeter.
2. Place a wire lead across the input of the DAS multiplexer. With this "shorted" out, the DAS should read zero.
3. If the output does not read zero, adjust the output according to the owners manual.
4. After the background zero has been determined, it is time to adjust the full scale of the system. Most DAS system work on a 1, 5 or 10 volt range, i.e., the full scale equals an output of voltage. In the case of a 0 - 1000 ppb range instrument, 1.00 volts equals 1000 ppb. Accordingly, 500 ppb equals 0.5 volts (500 milivolts). To get the DAS to be linear throughout the range of the instrument being measured, the DAS must be tested for linearity.
5. Attach the voltage source to a voltmeter. Adjust the voltage source to 1.000 volts (this is critical that the output be **1.000 volts**). Attach the output of the voltage source the DAS multiplexer. The DAS should read 1000 ppb. Adjust the DAS voltage A/D card accordingly. Adjust the output of the voltage source to 0.250 volts. The DAS output should read 250 ppb. Adjust the A/D card in the DAS accordingly. Once you have adjusted in the lower range of the DAS, check the full scale point. With the voltage source at 1.000 volts, the output should be 1000 ppb. If it isn't, then adjust the DAS to allow the high and low points to be as close to the source voltage as possible. In some cases, the linearity of the DAS may be in question. If this occurs, the data collected may need to be adjusted using a linear regression equation. See Section 2.0.9 for details on data adjustment. The critical range for many instruments is in the lower 10 % of the scale. It is critical that this be linear.
6. Every channel on a DAS should be calibrated. In some newer DAS systems, there is only one A/D card voltage adjustment which is carried throughout the multiplexer. This usually will adjust all channels. It is recommended that DAS be calibrated once per year.

## **Appendix H**

**United States Environmental Protection Agency**

**National Ambient Air Monitoring Technical System Audit Form**

Page intentionally left blank

## Table of Contents

- 1) General / Quality Management**
  - a) Program Organization
  - b) Facilities
  - c) Independent Quality Assurance and Quality Control
  - d) Planning Documents (including QMP, QAPPs, & SOPs)
  - e) General Documentation Policies
  - f) Training
  - g) Corrective Action
  - h) Quality Improvement
  - i) External Performance Audits
- 2) Network Management / Field Operations**
  - a) Network Design
  - b) Changes to the Network since the last audit
  - c) Proposed changes to the Network
  - d) Field Support
    - i) SOPs
    - ii) Instrument Acceptance
    - iii) Calibration
    - iv) Repair
    - v) Site and Monitor Information Form
- 3) Laboratory Operations**
  - a) Routine Operations
  - b) Quality Control
  - c) Laboratory Preventive Maintenance
  - d) Laboratory Record Keeping
  - e) Laboratory Data Acquisition and Handling
  - f) Specific Pollutants: PM<sub>10</sub>, PM<sub>2.5</sub> and Lead
- 4) Data and Data Management**
  - a.) Data Handling
  - b.) Software Documentation
  - c.) Data Validation and Correction
  - d.) Data Processing
  - e.) Internal Reporting
  - f.) External Reporting

## **1) General / Quality Management**

State/ Local / Tribal Agency Audited:

Address:

City, State, and Zip Code:

Date of Technical System Audit:

Auditor / Agency:

### **a) Program Organization**

1) Key Individuals

1.1) Agency Director:

1.2) Ambient Air Monitoring (AAM) Network Manager:

1.3) Quality Assurance Manager:

1.4) QA Auditors:

1.5) Field Operations Supervisor / Lead:

1.6) Laboratory Supervisor:

1.7) QA Laboratory Manager:

1.8) Data Management Supervisor / Lead:

Attach an Organizational Chart :



Flow Chart:

Key position staffing. Number of personnel available to each of the following program areas:							
Program Area	Number of People Primary	Number of People Backup	Vacancies	Program Area	Number of People Primary	Number of People Backup	Vacancies
Network Design and Siting				Data and Data Management			
QC activities				Equipment repair and maintenance			
QA activities				Financial Management			

List available personnel by name and percentage of time spent on each task category

Name	Network Design and siting	QC activities	QA activities	Equipment repair and maintenance	Data and Data Management	Financial Management

Comment on the need for additional personnel, if applicable

List personnel who have authority or are responsible for:

Activity	Name	Title
QA Training Field/Lab		
Grant Management		
Purchases greater than \$500		
Equipment and Service Contract Management		
Staff appointment		

## b) Facilities

Identify the principal facilities where the agency conducts work that is related to air monitoring. Do not include monitoring stations but do include facilities where work is performed by contractors or other organizations.			
Facility AAM Function	Offices responsible for ensuring adequacy	Location	Adequate Y/N To be completed by auditor
Instrument repair			
Certification of Standards e.g. gases, flow transfers, MFC			
PM filter weighing			
Data verification and processing			
General office space			
Storage space, short and long term			
Air Toxics (Carbonyls, VOC s, Metals):			
Indicate any facilities that should be upgraded. Identify by function and any suggested improvements or recommendations			
Are facilities adequate concerning safety? Yes / No Please explain if answer is no any suggested improvements or recommendations			

Are there any significant changes which are likely to be implemented to agency facilities within the next one to two years? Comment on agency's needs for additional physical space (laboratory, office, storage, etc.).		
Facility	Function	Proposed Change - Date

## c) Independent Quality Assurance and Quality Control

### 1. Status of Quality Assurance Program

Question	Yes	No	Comment
Does the agency perform QA activities with internal personnel? If no go to Section d.			
Does the agency maintain a separate laboratory to support quality assurance activities?			
Has the agency documented and implemented specific audit procedures separate from monitoring procedures?			
Are there two levels of management separation between QA and QC operations? Please explain:			
Does the agency have identifiable auditing equipment and standards (specifically intended for sole use) for audits?			

### 2. Internal Performance Audits

Question	Yes	No	Comment
Does the agency have separate facilities to support audits and calibrations?			
If the agency has in place contracts or similar agreements either with another agency or contractor to perform audits or calibrations, please name the organization and briefly describe the type of agreement.			
If the agency does not have a performance audit SOP (included as an attachment), please describe performance audit procedure for each type of pollutant.			
Does the agency maintain independence of audit standards and personnel?			
Please provide information on certification of audit standards currently being used. Include information on vendor and internal or external certification of standards.			
Does the agency have a certified source of zero air for performance audits?			
Does the agency have procedures for auditing and/or validating performance of Meteorological monitoring?			
Please provide a list of the agency's audit equipment and age of audit equipment.			

Is audit equipment ever used to support routine calibration and QC checks required for monitoring network operations?			
If yes, please describe.			
Are standard operating procedures (SOPs) for air monitoring available to all field personnel?			
Has the agency established and has it documented criteria to define agency-acceptable audit results?			

Please complete the table below with the pollutant, monitor and acceptance criteria.		
Pollutant	How is performance tracked (e.g., control charts)	Audit Result Acceptance Criteria
CO		
O <sub>3</sub>		
NO <sub>2</sub>		
SO <sub>2</sub>		
PM <sub>10</sub>		
PM <sub>2.5</sub>		
Pb		
VOCs		
Carbonlys		
PM <sub>2.5</sub> speciation		
PM <sub>10-2.5</sub> speciation		
PM <sub>10-2.5</sub> FRM Mass		
Continuous PM <sub>2.5</sub>		
Trace Levels (CO)		
Trace Levels (SO <sub>2</sub> )		
Trace Levels (NO)		
Trace Levels (NO <sub>y</sub> )		
Surface Meteorology		
Others		

Question	Yes	No	Comment
<p>Were these audit criteria based on, or derived from, the guidance found in Volume II of the QA Handbook for Air Pollution Measurement System, Section 2.0.12?</p>			<p>If no, please explain.</p> <p>If yes, please explain any changes or assumptions made in the derivation.</p>
<p>What corrective action may be taken if criteria are exceeded? If possible, indicate two examples of corrective actions, taken within the period since the previous systems audit which are based directly on the criteria discussed above.</p> <p>Corrective Action # 1</p> <p>Corrective Action #2</p>			

**d) Planning Documents including QMP, QAPP, &SOP**

<b>QMP questions</b>	<b>Yes</b>	<b>No</b>	
Does the agency have an EPA-approved quality management plan?			
If yes, have changes to the plan been approved by the EPA?			
Has the QMP been approved by EPA within the last five years?			
Please provide: Date of Original Approval                      Date of Last Revision:                      Date of Latest Approval:			
<b>QAPP questions</b>	<b>Yes</b>	<b>No</b>	<b>Comment</b>
Does the agency have an EPA-approved quality assurance project plan?			
If yes, have changes to the plan been approved by the EPA?			
Has the QAPP been reviewed by EPA annually?			
Please provide: Date of Original Approval                      Date of Last Revision                      Date of Latest Approval			
Does the agency have any revisions to your QA project plan still pending?			
How does the agency verify the QA project plan is fully implemented?			
How are the updates distributed?			
What personnel regularly receive updates?			
<b>SOP questions</b>			
Has the agency prepared and implemented standard operating procedures (SOPs) for all facets of agency operation?			
Do the SOPs adequately address ANSI/ASQC E-4 quality system required by 40 CFR 58, Appendix A?			
Are copies of the SOP or pertinent sections available to agency personnel?			
How does the agency verify that the SOPs are implemented as provided?			
How are the updates distributed?			

**e) General Documentation Policies**

Question	Yes	No	Comment
Does the agency have a documented records management plan?			
Does the agency have a list of files considered official records and their media type I.E. paper, electronic?			
Does the agency have a schedule for retention and disposition of records?			
Are records for at least three years?			
Who is responsible for the storage and retrieval of records?			
What security measures are utilized to protect records?			
Where/when does the agency rely on electronic files as primary records?			
What is the system for the storage, retrieval and backup of these files?			

## f) Training

Question	Yes	No	Comment
Does the agency have a training program and training plan?			
Where is it documented?			
Does it make use of seminars, courses, EPA sponsored college level courses?			
Are personnel cross-trained for other ambient air monitoring duties?			
Are training funds specifically designated in the annual budget?			
Does the training plan include:	<b>Yes</b>	<b>No</b>	<b>Comment</b>
Training requirements by position			
Frequency of training			
Training for contract personnel			
A list of core QA related courses			

Indicate below the three most recent training events and identify the personnel participating in them.		
Event	Dates	Participant(s)



### Oversight of Contractors and Suppliers

Question Contractors	Yes	No	Comment
Who is responsible for oversight of contract personnel?			
What steps are taken to ensure contract personnel meet training and experience criteria?			
How often are contracts reviewed and /or renewed?			
Question Suppliers			
Have criteria and specification been established for consumable supplies and for equipment?			
What supplies and equipment have established specifications?			
Is equipment from suppliers open for bid?			

### g) Corrective Action

Question	Yes	No	Comment
Does the agency have a comprehensive corrective action program in place and operational?			
Have the procedures been documented?			
As a part of the QA project plan?			
As a separate standard operating procedure?			
Does the agency have established and documented corrective limits for QA and QC activities?			
Are procedures implemented for corrective actions based on results of the following which fall outside the established limits:			
Performance evaluations			
Precision goals			
Bias goals			
NPAP audits			
PEP audits			

Question	Yes	No	Comment
Validation of one point QC check goals			
Completeness goals			
Data audits			
Calibrations and zero span checks			
Technical Systems Audit			
Have the procedures been documented?			
How is responsibility for implementing corrective actions assigned? Briefly discuss.			
How does the agency follow up on implemented corrective actions?			
Briefly describe recent examples of the ways in which the above corrective action system was employed to remove problems.			

## h) Quality Improvement

Question	Yes	No	Comment
What actions were taken to improve the quality system since the last TSA?			
Since the last TSA do your control charts indicate that the overall data quality for each pollutant steady or improving?			
For areas where data quality appears to be declining has a cause been determined?			
Have all deficiencies indicted on the previous TSA been corrected?			
If not explain.			
Are there pending plans for quality improvement such as purchase of new or improved equipment, standards, or instruments?			

### i) External Performance Audits

Question	Yes	No	Comment
Does your agency participate in NPAP, PM2.5 PEP, and Other performance audits performed by an external party and/or using external standards.			
If the agency does not participate, please explain why not:			
Are NPAP audits performed by QA staff, site operators, calibration staff, and/or another group?			

### National Performance Audit Program (NPAP) and Additional Audits

Does the agency participate in the National Performance Audit Program (NPAP) as required under 40 CFR 58, Appendix A? If so, identify the individual with primary responsibility for the required participation in the National Performance Audit Program.

Name:

Program function:

Please complete the table below:	
Parameter Audited	Date of Last NPAP Audit
CO	
O <sub>3</sub>	
SO <sub>2</sub>	
NO <sub>2</sub>	
PM <sub>10</sub>	
PM <sub>2.5</sub>	
Pb	
VOCs	
Carbonlys	

## 2) Network Management/Field Operations

State/Local/Tribal Agency Audited:

Address:

City, State, and Zip Code:

Auditor / Agency:

### **Key Individuals**

Ambient Air Monitoring Network Manager:

Quality Assurance Manager:

Field Operations Supervisor/Lead:

Field Operations Staff involved in the TSA:

### a) Network Design

Complete the table below for each of the pollutants monitored as part of your air monitoring network. (Record applicable count by category.) Also indicate seasonal monitoring with an S for a Parameter/Category as appropriate. Provide the most recent annual monitoring network plan, including date of approval and AQS quicklook or if not available, network description and other similar summary of site data, including SLAMS, Other and Toxics									
Category*	SO <sub>2</sub>	NO <sub>2</sub>	CO	O <sub>3</sub>	PM <sub>10</sub>	PM <sub>2.5</sub>	Pb	Other (type)	Other (type)
NCore									
SLAMS									
SPM									
PAMS									
<b>Total</b>									

\*NCore - National Core monitoring stations; SLAMS - state and local air monitoring stations; SPM - special purpose monitors; PAMS - photochemical assessment monitoring stations

Question	Yes	No	Comment
What is the date of the most current Monitoring Network Plan?			
I. Is it available for public inspection			
II. Does it include the information required for each site?			
AQS Site ID #			
Street address and geographic coordinates			
Sampling and Analysis Method(s)			
Operating Schedule			
Monitoring Objective and Scale of Representativeness			
Site suitable/not suitable for comparison to annual PM <sub>2.5</sub> NAAQS?			
MSA, CBSA or CSA indicated as required?			

Indicate by Site ID # any non-conformance with the requirements of 40 CFR 58, Appendices D and E, along with any waivers granted by the Regional Office (provide waiver documentation)		
Monitor	Site ID	Reason for Non-Conformance
SO <sub>2</sub>		
O <sub>3</sub>		
CO		
NO <sub>2</sub>		
PM <sub>10</sub>		
PM <sub>2.5</sub>		
Pb		

Question	Yes	No	Comment
Are hard copy site information files retained by the agency for all air monitoring stations within the network?			
Does each station have the required information including:			
AQS Site ID Number?			
Photographs/slides to the four cardinal compass points?			
Startup and shutdown dates?			
Documentation of instrumentation?			
Who has custody of the current network documents			Name: Title:
Does the current level of monitoring effort, station placement, instrumentation, etc., meet requirements imposed by current grant conditions?			
How often is the network siting reviewed?			Frequency: Date of last review:
Are there any issues			
Do any sites vary from the required frequency in 40 CFR 58.12?			
Does the number of collocated monitoring stations meet the requirements of 40 CFR 58 Appendix A?			

**b) Changes to the Network since the last audit**

What is the date of the most recent network assessment? (Provide copy) Are all SLAMS parameters included? Any Others?				
Please provide information on any site changes since the last audit				
Pollutant	Site ID	Site Address	Site Added/Deleted/Relocated	Reason (Assessment, lost lease, etc. Provide documentation of reason for each site change.)

### c) Proposed changes to the Network

Are future network changes proposed?				
Please provide information on proposed site changes, including documentation of the need for the change and any required approvals				
Pollutant	Site ID	Site Address	Site to be Added/Deleted/Relocated	Reason (Assessment, lost lease, etc. Provide documentation of reason for each site change.)

### d) Field Support

Question	Yes	No	Comment
On average, how often are most of your stations visited by a field operator?			_____ per _____
Is this visit frequency consistent for all reporting organizations within your agency?			
On average, how many stations does a single operator have responsibility for?			
How many of the stations of your SLAMS/NCORE network are equipped with sampling manifolds?			
Do the sample inlets and manifolds meet the requirements for through the probe audits?			
I. Briefly describe most common manifold type			
II. Are Manifolds cleaned periodically			How often?
III. If the manifold is cleaned, what is used to perform cleaning			
IV. Are manifold(s) equipped with a blower			
V. Is there sufficient air flow through the manifold at all times?			Approximate air flow:
VI. How is the air flow through the manifold monitored?			
VII. Is there a conditioning period for the manifold after cleaning?			Length of time:
VIII. What is the residence time?			
Sampling lines: 1) What material is used for instrument sampling lines?			
2) How often are lines changed?			
Do you utilize uninterruptable power supplies or backup power sources at your sites?			
What instruments or devices are protected?			



**i). SOPs**

Question	Yes	No	Comment
Is the documentation of monitoring SOPs complete?			
Are any new monitoring SOPs needed?			
Are such procedures available to all field operations personnel?			
Are SOPs that detail operations during episode monitoring prepared and available to field personnel?			
Are SOPs based on the framework contained in Guidance for Preparing Standard Operating Procedures EPA QA/G-6?			

**Please complete the following table:**

Pollutant Monitored	Date of Last SOP Review	Date of Last SOP Revision
SO <sub>2</sub>		
NO <sub>2</sub>		
CO		
O <sub>3</sub>		
PM <sub>10</sub>		
PM <sub>2.5</sub> FRM mass		
Pb		
PM <sub>2.5</sub> speciation		
PM <sub>10-2.5</sub> FRM mass		
PM <sub>10-2.5</sub> speciation		
Continuous PM <sub>2.5</sub> mass		
Trace levels (CO)		
Trace levels (SO <sub>2</sub> )		
Trace levels (NO)		
Trace levels (NO <sub>y</sub> ) Total reactive nitrogen		
Surface Meteorology Wind speed and direction, temperature, RH, precipitation and solar radiation		
Others		

**ii). Instrument Acceptance**

Has your agency obtained necessary waiver provisions to operate equipment which does not meet the effective reference and equivalency requirements? List all waivers.

Please list instruments in your inventory

Pollutant	Number	Make and Models	Reference or Equivalent number
SO <sub>2</sub>			
NO <sub>2</sub>			
CO			
O <sub>3</sub>			
PM <sub>10</sub>			
PM <sub>2.5</sub>			
Pb			
Multi gas calibrator			
PM <sub>2.5</sub> speciation			
PM <sub>10-2.5</sub> speciation			
PM <sub>10-2.5</sub> FRM mass			
Continuous PM <sub>2.5</sub> mass			
Trace levels (CO)			
Trace levels (SO <sub>2</sub> )			
Trace levels (NO)			
Trace levels (NO <sub>y</sub> )			
Surface Meteorology			
Others			

Please comment briefly and prioritize your currently identified instrument needs.

Question	Yes	No	Comment
Are criteria established for field QC equipment?			
Are criteria established for field QC gas standards?			

### iii) Calibration

Please indicate the frequency of multi point calibrations.		
Pollutant	Frequency	Name of Calibration Method

Question	Yes	No	Comment
Are field calibration procedures included in the document? SOPs?			Location (site, lab etc.):
Are calibrations performed in keeping with the guidance in section Vol II of the QA Handbook for Air Pollution Measurement Systems?			If no, why not?
Are calibration procedures consistent with the operational requirements of Appendices to 40 CFR 50 or to analyzer operation/instruction manuals?			If no, why not?
Have changes been made to calibration methods based on manufacturer's suggestions for a particular instrument?			
Do standard materials used for calibrations meet the requirements of appendices to 40 CFR 50 (EPA reference methods) and Appendix A to 40 CFR 58 (traceability of materials to NIST-SRMs or CRMs)?			Comment on deviations
Are all flow-measurement devices checked and certified?			
Additional comments:			
Please list the authoritative standards used for each type of flow measurement, indicate the certification frequency of standards to maintain field material/device credibility.			
Flow Device	Primary Standard	Frequency of Certification	
HiVol orifice			
Streamline			
TriCal			
BIOS			
DeltaCal			
Gilibrators			
Where do field operations personnel obtain gaseous standards?			
Are those standards certified by:			

Question	Yes	No	Comment
The agency laboratory?			
EPA/NERL standards laboratory?			
A laboratory separate from this agency's but part of the same reporting organization?			
The vendor?			
Other (describe).			
How are the gas standards verified after receipt?			
How are flow measurement devices certified?			
Please provide copies of certifications of all standards currently in use from your master and/or satellite standard certification logbooks (i.e., chemical standards, ozone standards, flow standards, and zero air standards) .			
What equipment is used to perform calibrations (e.g., dilution devices) and how is the performance of this equipment verified?			
Does the documentation include expiration date of certification?			
Reference to primary standard used?			
What traceability is used?			
Please attach an example of recent documentation of traceability			
Is calibration equipment maintained at each station?			
How is the functional integrity of this equipment documented?			
Who has responsibility for maintaining field calibration standards?			
Please list the authoritative standards and frequency of each type of dilution, permeation and ozone calibrator and indicate the certification frequency...			
Calibrator	Primary Standard	Frequency of Calibration	Certification
Permeation calibrator flow controller			
Permeation calibrator temperature			
Dilution calibrator air and gas flow controllers			
Field/working standard photometer			
Ozone generator			

o) Please identify station standards for gaseous pollutants at representative air monitoring stations (attach additional sheets as appropriate):			
Parameter	Station(s)	Identification of Standard(s)	Recertification Date(s)
CO			
NO <sub>2</sub>			
SO <sub>2</sub>			
O <sub>3</sub>			

**iv) Repair**

- a) Who is responsible for performing preventive maintenance?
- b) Is special training provided them for performing preventive maintenance? Briefly comment on background or courses.
- c) Is this training routinely reinforced? Yes \_\_\_ No \_\_\_  
If no, why not?
- d) What is your preventive maintenance schedule for each type of field instrumentation?
- e) If preventive maintenance is MINOR, it is performed at (check one or more): field station \_\_\_, headquarters facilities\_\_\_, equipment is sent to manufacturer
- f) If preventive maintenance is MAJOR, it is performed at (check one or more): field station\_\_\_, headquarters facilities\_\_\_, equipment is sent to manufacturer
- g) Does the agency have service contracts or agreements in place with instrument manufacturers? Indicate below or attach additional pages to show which instrumentation is covered?
- h) Comment briefly on the adequacy and availability of the supply of spare parts, tools and manuals available to the field operator to perform any necessary maintenance activities. Do you feel that this is adequate to prevent any significant data loss?
- i) Is the agency currently experiencing any recurring problem with equipment or manufacturer(s)? If so, please identify the equipment or manufacturer, and comment on steps taken to remedy the problem.
- j) Have you lost any data due to repairs in the last 2 years?  
More than 24 hours?  
More than 48 hours?  
More than a week?
- k) Explain any situations where instrument down time was due to lack of preventive maintenance or unavailability of parts.

## RECORD KEEPING

Question	Yes	No	Comment
What type of station logbooks are maintained at each monitoring station? (maintenance logs, calibration logs, personal logs, etc.)			
What information is included in the station logbooks?			
Who reviews and verifies the logbooks for adequacy of station performance?			
How is control of logbook maintained?			
Where is the completed logbook archived?			
What other records are used?			
Zero span record?			
Gas usage log?			
Maintenance log?			
Log of precision checks?			
Control charts?			
A record of audits?			
Please describe the use and storage of these documents.			
Are calibration records or at least calibration constants available to field operators?			
Please attach an example field calibration record sheet to this questionnaire.			

## V) Site/Monitor Information Form

PQAO \_\_\_\_\_

AQS Site Name \_\_\_\_\_

AQS Site Number \_\_\_\_\_

Agency Site Name/No. \_\_\_\_\_  
(if different than AQS Site Name/Number)

Site Address \_\_\_\_\_

City & County \_\_\_\_\_

Site Coordinates \_\_\_\_\_  
(specify lat/long or UTM)

Site Elevation (m) \_\_\_\_\_

Criteria Pollutants Monitored \_\_\_\_\_

\_\_\_\_\_

Other Parameters \_\_\_\_\_

Nearst Meterological Site \_\_\_\_\_  
(‘on site’ is met tower present at this site)

Photographs to and from each cardinal direction attached? \_\_\_\_\_  
(Yes or No)

Name(s) of Report Preparer(s) \_\_\_\_\_

Name(s) of Auditors \_\_\_\_\_

Date \_\_\_\_\_

Phone Number \_\_\_\_\_

## Site Map

Draw map of site and surrounding terrain and features, up to 100 meters.



## Map notes

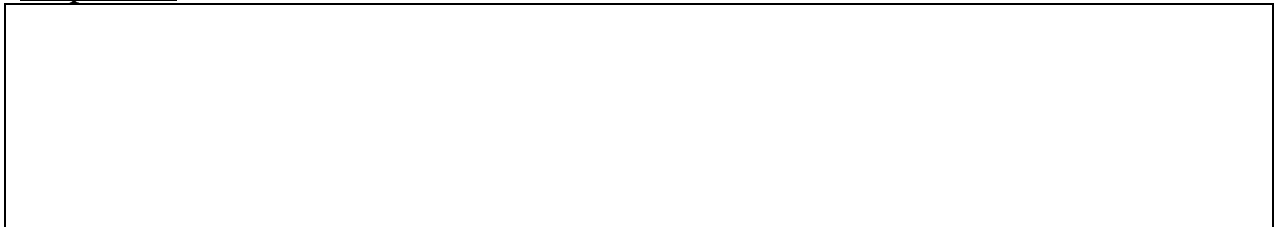



## Monitor Information

### Pollutants

Manufacturer			
Model			
Serial number			
Scale of representation MICro, MIDdle, Neighborhoood, Urban			
Objective (Population, Max concentration, Background, Transport)			
Height of probe above ground(m)			
Distance from obstruction (m)			
Type of obstruction (Wall, Tree, etc)			
Distance from roadway (m)			
Unrestricted airflow (Yes, No)			
Designation (NCore, SLAMS,etc)			
Siting Criteria Met (Yes, No)			

Manufacturer			
Model			
Serial number			
Scale of representation MICro, MIDdle, Neighborhoood, Urban			
Averaging time 1-, 8-, 24-hour			
Objective (Population, Max concentration, Background, Transport)			
Height of probe above ground(m)			
Distance from obstruction (m)			
Type of obstruction (Wall, Tree, etc)			
Distance from roadway (m)			
Unrestricted airflow (Yes, No)			
Designation (NCore, SLAMS,etc)			
Siting Criteria Met (Yes, No)			

Insert additional copies of table as needed

## Area Information

Street Name	Traffic Count (Vehicles/day)

Direction	Predominant Land Use (Industry, Residential, Commercial or Agriculture)
North	
East	
South	
West	

Direction	Obstructions	Height (m)	Distance (m)
North			
East			
South			
West			

Note: This table is for large obstructions that affect the entire site, such as large clusters of trees or entire buildings. Individual obstructions, such as walls, single trees, other monitors, etc, should be entered in the Monitor Information table.

Direction	Topographic Features (hills, valleys, rivers, etc.)	General Terrain (flat, rolling, rough)
North		
East		
South		
West		

## Comments

### **3) LABORATORY OPERATIONS**

State/Local/Tribal Agency Audited:

City, State, and Zip Code:

Date of Technical System Audit:

Auditor / Agency:

#### **Key Individuals**

Laboratory Manager:

Laboratory Supervisor:

Quality Assurance Manager:

Laboratory Staff involved in the TSA:

**a) Routine Operations**

What analytical methods are employed in support of your air monitoring network?

Analysis	Name or Description of Method
PM <sub>10</sub>	
PM <sub>2.5</sub>	
Pb	
Others (list by pollutant)	

Please describe areas where there have been difficulties meeting the regulatory requirements for any of the above analytical methods.

In the table below, please identify the current versions of written methods, supplements, and guidelines that are used in your agency.

Analysis	Documentation of Method
PM <sub>10</sub>	
PM <sub>2.5</sub>	
Pb	
Others (list by pollutant)	

Question	Yes	No	Comment
Were procedures for the methods listed above included in the agency's QA Project Plan or SOP's and were reviewed by EPA? Also, are SOP's easily/readily accessible for use and reference?			
Does your lab have sufficient instrumentation to conduct analyses?			

d) Please describe needs for laboratory instrumentation.

## b) Laboratory Quality Control

Please identify laboratory standards used in support of the air monitoring program, including standards which may be kept in an analytical laboratory and standards which may be kept in a field support area or quality assurance laboratory that is dedicated to the air monitoring program (attach additional sheets if appropriate):

Parameter	Location of Standards	Laboratory Standard	Recertification Date	Primary Standard*
CO				
NO <sub>2</sub>				
SO <sub>2</sub>				
O <sub>3</sub>				
Weights				
Temperature				
Moisture				
Barometric Pressure				
Flow				
Other Flow Standard				
Lead				
Other				

\*Standards to which the laboratory standards can be traced.

Question	Yes	No	Comment
Are all chemicals and solutions clearly marked with an indication of shelf life?			
Are chemicals removed and properly disposed of when shelf life expires?			
Are only ACS grade chemicals used by the laboratory?			
e) Comment on the traceability of chemicals used in the preparation of calibration standards			

Question	Yes	No	Comment
Does the laboratory purchase standard solutions such as those for use with lead or other metals analysis?			
Are all calibration procedures documented?			
If answer "yes" to (f), please describe the following: (1) Title of the document: (2) Revision number: (3) Where the document is:			
Are at least one duplicate, one blank, and one standard or spike included with a given analytical batch?			
Briefly describe the laboratory's use of data derived from blank analyses.			
Are criteria established to determine whether a blank data are acceptable?			
How frequently and at what concentration ranges does the lab perform duplicate analysis? What constitutes <i>an</i> acceptable agreement? Please comment in the space below.			
Please describe how the lab use data obtained from spiked samples, including the acceptance criteria (e.g., acceptable percent recovery).			

Question	Yes	No	Comment
Does the laboratory routinely include samples of reference material within an analytical batch?			
If yes, indicate frequency, level, and material used.			
Are mid-range standards included in analytical batches?			
Please describe the frequency, level and compound used in the space provided below.			

Question	Yes	No	Comment
Are criteria for real time quality control established that are based on the results obtained for the mid-range standards discussed above?			
If yes, briefly discuss them below or indicate the document in which they can be found.			
Are appropriate acceptance criteria for each type of analysis documented ?			

### c) Laboratory Preventive Maintenance

Question	Yes	No	Comment
For laboratory equipment, who has the responsibility for performing preventive maintenance?			
Is most maintenance performed in the lab?			
Is a maintenance log maintained for each major laboratory instrument?			
Are service contracts in place for major analytical instruments?			

### d) Laboratory Record Keeping

Question	Yes	No	Comment
Are all samples that are received by the laboratory logged in?			
Discuss sample routing and special needs for analysis (or attach a copy of the latest SOP which covers this). Attach a flow chart if possible.			
Are log books kept for all analytical laboratory instruments?			
Are there log books or other records that indicate the checks made on materials and instruments such as weights, humidity indicators, balances, and thermometers?			
Identify type of record, acceptable/non-acceptable			
Are log books maintained to track the preparation of filters for the field?			
Are they current?			
Do they indicate proper use of conditioning?			
Weighings?			
Stamping and numbering?			
Are log books kept which track filters returning from the field for analysis?			
<p>How are data records from the laboratory archived?</p> <p>Where?</p> <p>Who has the responsibility? Person</p> <p>Title</p> <p>How long are records kept? Years</p>			
Does a chain-of-custody procedure exist for laboratory samples?			
If yes, indicate date, title and revision number where it can be found			



### e) Laboratory Data Acquisition and Handling

Question	Yes	No	Comment
Identify those laboratory instruments which make use of computer interfaces directly to record data. Which ones use strip charts? Integrators?			
Are QC data readily available to the analyst during a given analytical run?			
What is the laboratory's capability with regard to data recovery? In case of problems, can they recapture data or are they dependent on computer operations? Discuss briefly.			
Has a user's manual been prepared for the automated data acquisition instrumentation?			
Please provide below a data flow diagram which establishes, by a short summary flow chart: transcriptions, validations, and reporting format changes the data goes through before being released by the laboratory.			

### f) Specific Pollutants: PM<sub>10</sub>, PM<sub>2.5</sub> and Lead

Question	Yes	No	Comment
<b><u>PM<sub>10</sub> and PM<sub>2.5</sub></u></b>			
Does the agency use filters supplied by EPA?			
Do filters meet the specifications in 40 CFR 50?			
Are filters visually inspected via strong light from a view box for pinholes and other imperfections?			
Where does the laboratory keep records of the serial numbers of filters?			
Are unexposed filters equilibrated in controlled conditioning environment which meets or exceeds the requirements of 40 CFR 50?			
Are the temperature and relative humidity of the conditioning environment monitored?			
Are the temperature and humidity monitors calibrated?			
Are balances checked with Class S or Class M weights each day when they are used?			
Is the balance check information placed in QC log book?			
To what sensitivity are filter weights recorded?			
Are filter serial numbers and tare weights recorded in a bound notebook?			
Are filters packaged for protection while transporting to and from the monitoring stations?			
How often are filter samples collected? (Indicate the average elapsed time in hours between end of sampling and laboratory receipt.)			
In what medium are field measurements recorded (e.g., in a log book, on a filter folder, or on standard forms)?			
Are exposed filters reconditioned for at least 24 hrs in the same conditioning environment as for unexposed filters?			
Briefly describe how exposed filters are prepared for conditioning.			
Briefly describe how exposed filters are stored after being weighed.			

Question	Yes	No	Comment
Are blank filters reweighed?			
Are chemical analyses performed on filters?			
<b>LEAD</b>			
Is analysis for lead being conducted using atomic absorption spectrometry with air acetylene flame?			If not, has the agency received an equivalency designation of their procedure?
Is either the hot acid or ultrasonic extraction procedure being followed precisely?  Is Class A borosilicate glassware used throughout the analysis?			Which?
Is all glassware cleaned with detergent, soaked and rinsed three times with distilled or deionized water?			
If extracted samples are stored, are linear polyethylene bottles used?			
Are all batches of glass fiber filters tested for background lead content?			
At a rate of 20 to 30 random filters per batch of 500 or greater?			Indicate rate.
Are ACS reagent grade HNO <sub>3</sub> and HCl used in the analysis?			
Is a calibration curve available having concentrations that cover the linear absorption range of the atomic absorption instrumentation?			
Is the stability of the calibration curve checked by alternately remeasuring every 10th sample a concentration $\leq 1\mu\text{g Pb/ml}$ ; $\leq 10\mu\text{g Pb/ml}$ ?			

#### **4) DATA AND DATA MANAGEMENT**

State/Local/Tribal Agency Audited:

City, State, and Zip Code:

Date of Technical System Audit:

Auditor / Agency:

##### **Key Individuals**

Data Manager:

Data Supervisor:

Quality Assurance Manager:

### a) Data Handling

Question	Yes	No	Comment
Is there a procedure, description, or a chart which shows a complete data sequence from point of acquisition to point of submission of data to EPA?			
Please provide below a data flow diagram indicating both the data flow within the reporting organization.			
Are procedures for data handling (e.g., data reduction, review, etc.) documented?			
In what media (e.g., diskette, data cartridge, or telemetry) and formats do data arrive at the data processing location? Please list below.			
<b>Category of Data (by Pollutant)</b>	<b>Data Media and Formats</b>		
How often are data received at the processing location from the field sites and laboratory?			
Is there documentation accompanying the data regarding any media changes, transcriptions, or flags which have been placed into the data before data are released to agency internal data processing?			
Describe the type of documentation			
How data are actually entered to the computer system (e.g., computerized transcription (copy from disk or data transfer device), manual entry, digitization of strip charts, or other)?			
For manual data, is a double-key entry system used?			

## b) Software Documentation

Question	Yes	No	Comment
Does your agency use any AQS Manual?			
Does your agency use any Air Now Manual?			
If yes, list the title of manual used including the , version number and date published			
Does the agency have information on the reporting of precision and accuracy data available?			
What are the origins of the software used to prepare air monitoring data for release into the AQS and AirNow database? Please list the documentation for the software currently in use for data processing, including the names of the software packages, vendor or author, revision numbers, and the revision dates of the <i>software</i> .			
What is the recovery capability in the event of a significant computer problem ( i.e., how much time and data would be lost)?			
Has your agency tested the data processing software to ensure its performance of the intended function are consistent with the QA Handbook, Volume II, and Section 14.0?			
Does your agency document software tests?			
If yes, provide the documentation			

### c) Data Validation and Correction

Question	Yes	No	Comment
Have your agency established and document the validation criteria ?			If yes, indicate document where such criteria can be found (title, revision date).
Does documentation exist on the identification and applicability of flags (i.e., identification of suspect values) within the data as recorded with the data in the computer files?			
Does your agency document the data validation criteria including limits for values such as flow rates, calibration results, or range tests for ambient measurements?			
(i) If yes, please describe what action the data validator will take if he/she find data with limits exceeded (e.g., flags, modifies, or delete, etc.) .			
(ii) If yes, give examples to illustrate actions taken when limits were exceeded.			
Please describe how changes made to data that were submitted to AQS and AirNow are documented.			
Who has signature authority for approving corrections? Name _____ Program function _____			
What criteria are used to determine a data point be deleted? Discuss briefly.			
What criteria are used to determine if data need to be reprocessed? Discuss.			
Are <u>corrected</u> data resubmitted to the issuing group for cross-checking prior to release?			

## d) Data Processing

Question	Yes	No	Comment
Does the agency generate data summary reports?			
Please list at least three reports routinely generated, <i>including</i> the information requested below.			
Report Title	Distribution		Period Covered

Question	Yes	No	Comment
How often are data submitted to AQS and AirNow?			
Briefly comment on difficulties the agency may have encountered in coding and submitting data following the guidance of the AQS guidelines?			
Does the agency routinely request a hard copy printout on submitted data from AQS?			
Are records kept for at least 3 years by the agency in an orderly, accessible form?			
If yes, does this include raw data __ , calculation __ , QC data __ , and reports __ ? If no, please comment			
Has your agency submitted data along with the appropriate calibration equations used to the processing center?			
Are concentrations of pollutants other than PM <sub>2.5</sub> corrected to EPA standard temperature and pressure conditions (i.e., 298°K, 760 mm Hg) before input to AQS, and concentrations of PM <sub>2.5</sub> reported to AQS under actual (volumetric) conditions?			:
Are audits on data reduction procedure performed on a routine basis?			
If yes, at what frequency?			
Are data precision and accuracy checked each time they are calculated, recorded, or transcribed to ensure that incorrect values are not submitted to EPA?			



### e) Internal Reporting

What internal reports are prepared and submitted as a result of the audits required under 40 CFR 58, Appendix A?	
Report Title	Frequency

What internal reports are prepared and submitted as a result of precision checks also required under 40 CFR 58, Appendix A?	
Report Title	Frequency

Question	Yes	No	Comment
Do either the audit or precision <i>check</i> reports indicated include a discussion of corrective actions initiated based on audit or precision <i>check</i> results?			

Who has the responsibility for the calculation and preparation of data summaries? To whom are such summaries delivered?			
Name	Title	Type of Report	Recipient

## f) External Reporting

For the current calendar year or portion thereof which ended at least 90 calendar days prior to the receipt of this questionnaire, please provide the following percentages for required data submitted on time.							
Percent Submitted on Time*				Period Covered:			
Monitoring Qtr.	SO <sub>2</sub>	CO	O <sub>3</sub>	NO <sub>2</sub>	PM <sub>10</sub>	PM <sub>2.5</sub>	Pb
1 (Jan 1 - March 31)							
2 (Apr 1 - June 30)							
3 (July 1 - Sept. 30)							
4 (Oct.1 - Dec. 31)							

\*"On time" = within 90 calendar days after the end of the quarter in which the data were collected.

For the same period, what fraction of the stations (by pollutant) reported less than 75% of the data (adjusted for seasonal monitoring and site start-ups and terminations)?							
Percent of Stations <75% Data Recovery				Period Covered:			
Monitoring Qtr.	SO <sub>2</sub>	CO	O <sub>3</sub>	NO <sub>2</sub>	PM <sub>10</sub>	PM <sub>2.5</sub>	Pb
1 (Jan 1 - March 31)							
2 (Apr 1 - June 30)							
3 (July 1 - Sept. 30)							
4 (Oct.1 - Dec. 31)							

Identify the individual within the agency with the responsibility for reviewing and releasing the data.

Name \_\_\_\_\_ Program function \_\_\_\_\_

Question	Yes	No	Comment
Does your agency report the Pollutant Standard Index?			
Has your agency submitted its annual data summary report (as required in 40 CFR 58.26)?			
If yes, did your agency's annual report include the following:			
Data summary required in Appendix F?			
Annual precision and accuracy information described in Section 5.2 of Appendix A?			
Location, date, pollution source and duration of all episodes reaching the significant harm levels?			
Is Data Certification signed by a senior officer of your agency?			

## **Appendix I**

### **Examples of Reports to Management**

The following example of an annual quality assurance report consist of a number of sections that describe the quality objectives for selected sets of measurement data and how those objectives have been met. Sections include:

- Executive Summary,
- Introduction, and
- Quality information for each ambient air pollutant monitoring program.

The report is titled "Acme Reporting Organization, Annual Quality Assurance Report for 2000".

**ACME REPORTING ORGANIZATION  
ANNUAL QUALITY ASSURANCE REPORT FOR 2000**

Prepared by

Quality Assurance Department  
Acme Reporting Organization  
110 Generic Office Building  
Townone XX, 00001

April 2001

**ACME REPORTING ORGANIZATION  
ANNUAL QUALITY ASSURANCE REPORT FOR 2000  
TABLE OF CONTENTS**

**EXECUTIVE SUMMARY**

**INTRODUCTION**

- ▶Data quality
- ▶Quality assurance procedures

**GASEOUS CRITERIA POLLUTANTS**

- ▶Program update
- ▶Quality objectives for measurement data
- ▶Data quality assessment

**PARTICULATE CRITERIA POLLUTANTS**

- ▶Program update
- ▶Quality objectives for measurement data
- ▶Data quality assessment

**TOTAL AND SPECIATED VOLATILE ORGANIC COMPOUNDS**

- ▶Program update
- ▶Quality objectives for measurement data
- ▶Data quality assessment

**AIR TOXIC COMPOUNDS**

- ▶Program update
- ▶Quality objectives for measurement data
- ▶Data quality assessment

## ACME REPORTING ORGANIZATION ANNUAL QUALITY ASSURANCE REPORT FOR 2000

### EXECUTIVE SUMMARY

This summary describes the Acme Reporting Organization's (ARO's) success in meeting its quality objectives for ambient air pollution monitoring data. ARO's attainment of quantitative objectives, such as promptness, completeness, precision, and bias, are shown in Table 1, below. ARO met these objectives for all pollutants, with the exception of nitrogen dioxide. The failure to meet completeness and timeliness goals for nitrogen dioxide was due to the breakdown of several older analyzers. Replacement parts were installed and the analyzers are now providing data that meet ARO's quality objectives.

**Table 1. Attainment of Quantitative Quality Objectives for Ambient Air Monitoring Data**

Measurement	Program met objectives for			
	Promptness	Completeness	Precision	Bias
Air Toxics	Yes	Yes	Yes	Yes
Carbon Monoxide	Yes	Yes	Yes	Yes
Lead	Yes	Yes	Yes	Yes
Nitrogen Dioxide	No	No	Yes	Yes
Ozone	Yes	Yes	Yes	Yes
Sulfur Dioxide	Yes	Yes	Yes	Yes
PM <sub>10</sub>	Yes	Yes	Yes	Yes
PM <sub>2.5</sub>	Yes	Yes	Yes	Yes
Volatile Organic Compounds (VOCs)	Yes	Yes	Yes	Yes

Other quality objectives (for example those concerning siting, recordkeeping, etc.) were assessed via laboratory and field system audits. The results of these audits indicate compliance with ARO's standard operating procedures except for the following:

- The Towntwo site was shadowed by a 20 story office building which was recently completed. This site was closed in July 2000.
- The Townfour site had problems with vandalism. A new, more secure, fence was installed in April and the sheriff's department increased patrols in the area to prevent reoccurrences.
- Newly acquired laboratory analytical instruments did not have maintenance logs. New logs were obtained and personnel were instructed on their use. A spot check, approximately one month later, indicated the new logs were in use.

A review of equipment inventories identified three older sulfur dioxide ambient air monitors that, based on our past experience, are likely to experience problems. Cost information and a schedule for replacement has been prepared and submitted to management for funding. Based on this schedule, the new monitors will be installed before the end of 2001.

## INTRODUCTION

The Acme Reporting Organization (ARO) conducts ambient air monitoring programs for the State Bureau of Environmental Quality and local air quality management districts. These programs involve:

- monitoring of criteria pollutants to determine the National Ambient Air Quality Standards (NAAQS) attainment status of state and local air quality. This monitoring is conducted as part of the State and Local Air Monitoring Stations (SLAMS) and National Air Monitoring Stations (NAMS) networks.
- monitoring compounds (volatile organic compounds and nitrogen oxides), referred to as ozone precursors, that can produce the criteria pollutant ozone. This monitoring is conducted as part of the Photochemical Assessment Monitoring Stations (PAMS) network.
- monitoring toxic air pollutants.

The purpose of this report is to summarize the results of quality assurance activities performed by ARO to ensure that the data meets its quality objectives. This report is organized by ambient air pollutant category (e.g., gaseous criteria pollutants, air toxics). The following are discussed for each pollutant category:

- ▶ program overview and update
- ▶ quality objectives for measurement data
- ▶ data quality assessment

## DATA QUALITY

Data quality is related to the need of users for data of sufficient quality for decision making. Each user specifies their needed data quality in the form of their data quality objectives (DQOs). Quality objectives for measurement data are designed to ensure that the end user's DQOs are met. Measurement quality objectives are concerned with both with quantitative objectives (such as representativeness, completeness, promptness, accuracy, precision and detection level) and qualitative objectives (such as site placement, operator training, and sample handling techniques).

## QUALITY ASSURANCE PROCEDURES

Quality assurance is a general term for the procedures used to ensure that a particular measurement meets the quality requirements for its intended use. In addition to performing tests to determine bias and precision, additional quality indicators (such as sensitivity, representativeness, completeness, timeliness, documentation quality, and sample custody control) are also evaluated. Quality assurance procedures fall under two categories:

- **quality control** - procedures built into the daily sampling and analysis methodologies to ensure data quality, and
- **quality assessment** - which refers to periodic outside evaluations of data quality.

Some ambient air monitoring is performed by automated equipment located at field sites, while other measurements are made by taking samples from the field to the laboratory for analysis. For this reason, we will divide quality assurance procedures into two parts – field and laboratory quality assurance.

## **Field Quality Assurance**

Quality control of automated analyzers and samplers consists of calibration and precision checks. The overall precision of sampling methods is measured using collocated samplers. Quality assurance is evaluated by periodic performance and system audits.

Calibration - Automated analyzers (except ozone) are calibrated by comparing the instrument's response when sampling a cylinder gas standard mixture to the cylinder's known concentration level. The analyzer is then adjusted to produce the correct response. Ozone analyzers are calibrated by on-site generation of ozone whose concentration is determined by a separate analyzer which has its calibration traceable to the U.S. Environmental Protection Agency. The site's analyzer is then adjusted to produce the same measured concentration as the traceable analyzer. Manual samplers are calibrated by comparing their volumetric flow rate at one or more flow rates to the flow measured by a flow rate transfer standard. Calibrations are performed when an instrument is first installed and at semi-annual intervals thereafter. Calibrations are also performed after instrument repairs or when quality control charts indicate a drift in response to quality control check standards.

Precision - Precision is a measure of the variability of an instrument. The precision of automated analyzers is evaluated by comparing the sample's known concentration against the instrument's response. The precision of manual samplers is determined by collocated sampling – the simultaneous operation of two identical samplers placed side by side. The difference in the results of the two samplers is used to estimate the precision of the entire measurement process (i.e., both field and laboratory precision).

Performance Audits - The bias of automated methods is assessed through field performance audits. Performance audits are conducted by sampling a blind sample (i.e., a sample whose concentration is known, but not to the operator). Bias is evaluated by comparing the measured response to the known value. Typically, performance audits are performed annually using blind samples of several different concentrations.

System Audits - System audits indicate how well a sampling site conforms to the standard operating procedures as well as how well the site is located with respect to its mission (e.g., urban or rural sampling, special purpose sampling site, etc.). System audits involve sending a trained observer (QA Auditor) to the site to review the site compliance with standard operating procedures. Some areas reviewed include: site location (possible obstruction, presence of nearby pollutant sources), site security, site characteristics (urban versus suburban or rural), site maintenance, physical facilities (maintenance, type and operational quality of equipment, buildings, etc.), recordkeeping, sample handling, storage and transport.

## **Laboratory Quality Assurance**

Laboratory quality control includes calibration of analytical instrumentation, analysis of blank samples to check for contamination, and analysis of duplicate samples to evaluate precision. Quality assurance is accomplished through laboratory performance and system audits.

Calibration - Laboratory analytical instruments are calibrated by comparing the instrument's response when sampling standards of known concentration level. The difference between the measured and known concentrations is then used to adjust the instrument to produce the correct response.

Blank Analysis - A blank sample is one that has intentionally not been exposed to the pollutant of interest.



Analysis of blank samples reveals possible contamination in the laboratory or during field handling or transportation.

Duplicate Analysis - Duplicate analyses of the same sample are performed to monitor the precision of the analytical method.

Performance Audits - Regular performance audits are conducted by having the laboratory analyze samples whose physical or chemical properties have been certified by an external laboratory or standards organization. The difference between the laboratory's reported value and the certified values is used to evaluate the analytical method's accuracy.

System Audits - System audits indicate how well the laboratory conforms to its standard operating procedures. System audits involve sending a trained observer (QA Auditor) to the laboratory to review compliance with standard operating conditions. Areas examined include: record keeping, sample custody, equipment maintenance, personnel training and qualifications, and a general review of facilities and equipment.

## GASEOUS CRITERIA POLLUTANTS

The Acme Reporting Organization monitors the ambient concentrations of the gaseous criteria pollutants carbon monoxide (CO), nitrogen dioxide (NO<sub>2</sub>), ozone (O<sub>3</sub>), and sulfur dioxide (SO<sub>2</sub>) to determine attainment of Federal (NAAQS) and State ambient air quality standards. Monitoring of these pollutants is conducted continuously by a network of automated stations.

### PROGRAM UPDATE

At the beginning of 2000, the Acme Reporting Organization operated 38 ambient air monitoring stations that measured gaseous criteria pollutants. On March 1, 2000, a station was opened at Townone to monitor CO, NO<sub>2</sub>, O<sub>3</sub>, and SO<sub>2</sub>. The station at Towntwo, which monitored NO<sub>2</sub>, O<sub>3</sub>, and SO<sub>2</sub>, was closed in April 2000.

### QUALITY OBJECTIVES FOR MEASUREMENT DATA

The Quality Objectives for the Acme Reporting Organization's ambient air monitoring of gaseous criteria pollutants are shown in Table 2, below.

<b>Table 2. Quality Objectives for Gaseous Criteria Pollutants</b>	
<b>Data Quality Indicator</b>	<b>Objective</b>
Precision	± 10%
Bias	± 15%
Completeness	75%
Promptness	100%

### DATA QUALITY ASSESSMENT

#### Summary

Assessment of the data quality for ARO gaseous criteria pollutants showed that all instruments met goals for accuracy, precision, completeness, and promptness. System audits showed siting problems at three sites, two of these were corrected promptly, while the third site had to be closed due to the construction of a nearby large office building.

### Promptness and Completeness

At least 75 percent of scheduled monitoring data must be reported for purposes of determining attainment of NAAQS. All data must be submitted within 90 days after the end of the reporting quarter. Table 3 summarizes promptness and completeness for gaseous criteria pollutant data.

<b>Table 3. Data Quality Assessment for Promptness and Completeness</b>		
<b>Pollutant</b>	<b>Promptness</b>	<b>Completeness</b>
Carbon monoxide	100%	95%
Nitrogen dioxide	100%	97%
Ozone	100%	94%
Sulfur dioxide	100%	96%

### Precision

At least once every two weeks, precision is determined by sampling a gas of known concentration. Table 4 summarizes the precision checks for gaseous criteria pollutants.

<b>Table 4. Data Quality Assessment for Precision</b>		
<b>Pollutant</b>	<b>Precision checks completed</b>	<b>Percentage within limits</b>
Carbon monoxide (CO)	98%	98%
Nitrogen dioxide (NO <sub>2</sub> )	100%	97%
Ozone (O <sub>3</sub> )	97%	98%
Sulfur dioxide (SO <sub>2</sub> )	100%	98%

### Bias

The results of annual performance audits conducted by ARO personnel are shown in Figure 1, below. The center line for each pollutant represents the average bias across all analyzers (i.e., with all analyzers weighted equally). The lower and upper probability limits represent the boundaries within which 95 percent of the individual bias values are expected to be distributed.

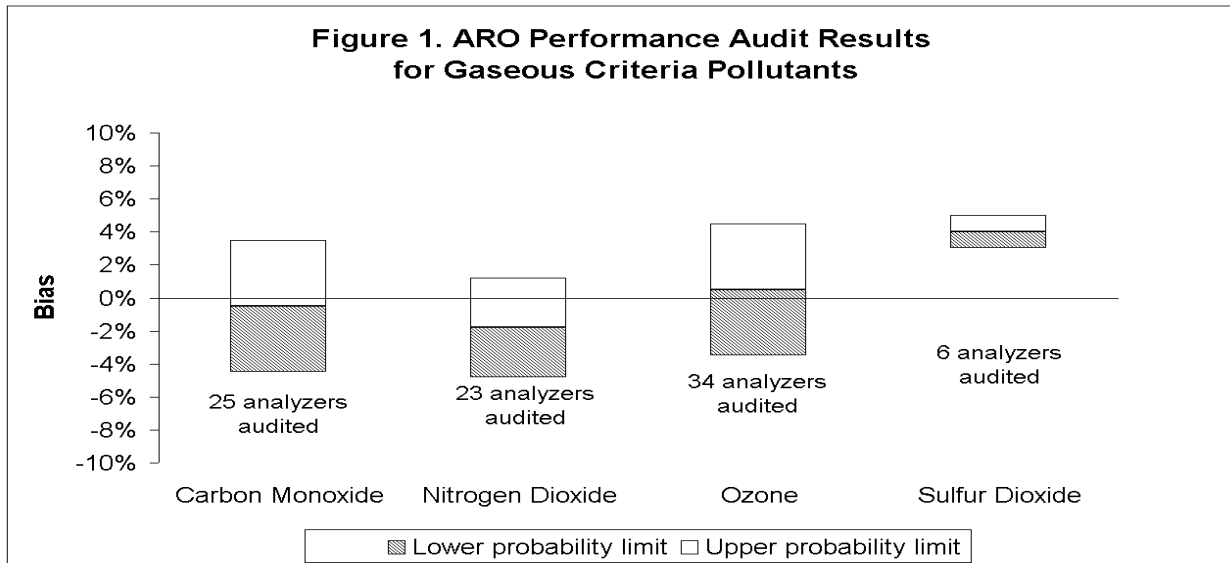
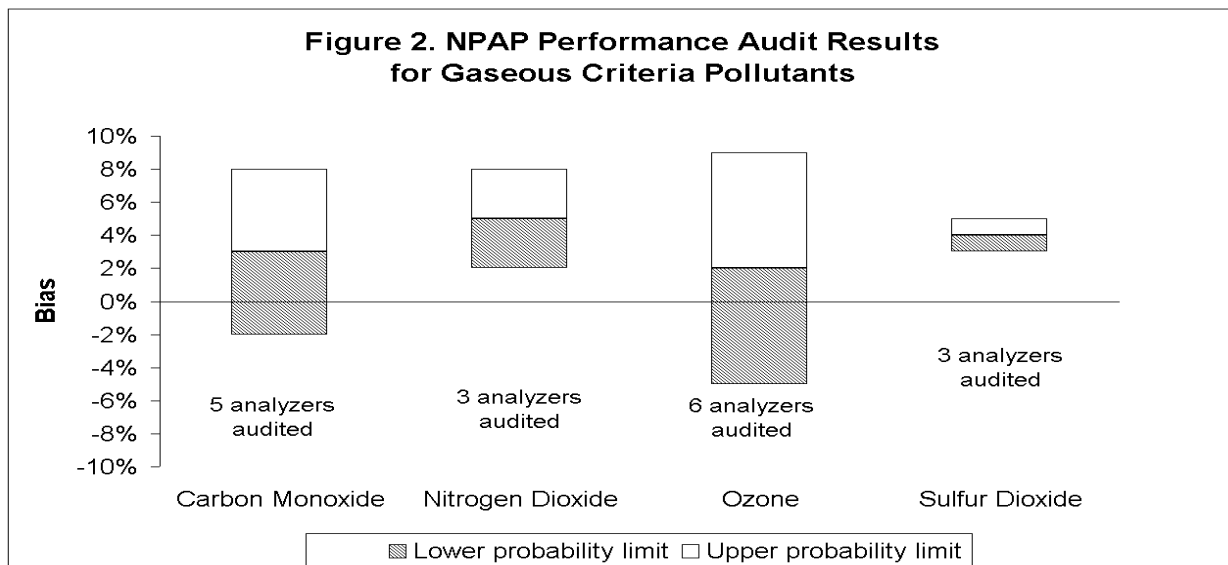

Figure 2 shows the results of external performance audits performed with the National Performance Audit Program (NPAP), administered by the U.S. EPA.



## **System Audits**

Systems audits were performed at approximately 25 percent of the sites during the calendar year 2000. These audits evaluated areas such as siting criteria, analyzer operation and maintenance, operator training, recordkeeping, and serve as a general review of site operations. No significant problems were observed, except for the following:

- The Towntwo site was shadowed by a 20 story office building which was recently completed. This site was closed in July 2000.
- The Townfour site had problems with repeated vandalism. A new, more secure, fence was installed in April and the sheriff's department increased patrols in the area to prevent reoccurrences.
- The Townsix site had vegetation which had grown too close to the analyzer inlet probes. The vegetation was removed within one week after the problem was reported. Personnel from the County Parks and Recreation Department provided assistance removing the vegetation.

## PARTICULATE CRITERIA POLLUTANTS

The Acme Reporting Organization monitors the ambient concentrations of three particulate criteria pollutants:

- Lead;
- PM<sub>10</sub> (particles with an aerodynamic diameter less than or equal to a nominal 10 micrometers; and
- PM<sub>2.5</sub> (particles with an aerodynamic diameter less than or equal to a nominal 2.5 micrometers)

This monitoring is used to determine attainment of Federal (NAAQS) and State ambient air quality standards. Monitoring of these pollutants is conducted by sampling for 24 hours every six days by a network of manually operated samplers.

### PROGRAM UPDATE

At the beginning of 2000, the Acme Reporting Organization operated 22 ambient air monitoring stations that measured particulate criteria pollutants. On March 1, 2000, a station was opened at Townone to monitor PM<sub>10</sub>, PM<sub>2.5</sub>, and lead. The station at Towntwo, which monitored PM<sub>10</sub>, PM<sub>2.5</sub>, and lead, was closed in April 2000.

### QUALITY OBJECTIVES FOR MEASUREMENT DATA

The Quality Objectives for the Acme Reporting Organization's ambient air monitoring of particulate criteria pollutants are shown in Table 5, below.

<b>Table 5. Quality Objectives for Particulate Criteria Pollutants</b>	
<b>Data Quality Indicator</b>	<b>Objective</b>
Precision	±7%
Bias	±10%
Completeness	75%
Promptness	100%

### DATA QUALITY ASSESSMENT

#### Summary

Assessment of the data quality for ARO particulate criteria pollutants showed that all samplers met goals for accuracy, precision, completeness, and promptness. System audits showed siting problems at three sites. Two of these were corrected promptly, while the third site had to be closed due to the construction of a large office building, nearby.

## Promptness and Completeness

At least 75 percent of scheduled monitoring data must be reported for purposes of determining attainment of NAAQS. All data must be submitted within 90 days after the end of the reporting quarter. Table 6 summarizes promptness and completeness data for particulate criteria pollutants.

<b>Table 6. Data Quality Assessment for Promptness and Completeness</b>		
<b>Pollutant</b>	<b>Promptness</b>	<b>Completeness</b>
Lead	100%	93%
PM <sub>10</sub>	100%	95%
PM <sub>2.5</sub>	100%	92%

## Precision

Precision is determined by operating collocated samplers (i.e., two identical samplers operated in the identical manner). Due to the anticipated poor precision for very low levels of pollutants, only collocated measurements above a minimum level (0.15  $\mu\text{g}/\text{m}^3$  for lead, 20  $\mu\text{g}/\text{m}^3$  for PM<sub>10</sub>, and 6  $\mu\text{g}/\text{m}^3$  for PM<sub>2.5</sub>) are used to evaluate precision. Table 7 summarizes the results of collocated measurements made during the calendar year 2000.

<b>Table 7. Data Quality Assessment for Precision</b>		
<b>Pollutant</b>	<b>Collocated precision measurements completed</b>	<b>Collocated measurements within limits</b>
Lead	98%	98%
PM <sub>10</sub>	100%	97%
PM <sub>2.5</sub>	97%	98%

### Flow rate precision

A flow rate precision check is conducted at least every two weeks for PM<sub>10</sub> and PM<sub>2.5</sub> samplers. The flow should be within ±10% of the specified value. Results are shown in Table 8.

<b>Table 8. Flow Rate Precision Checks for Particulate Criteria Pollutants</b>		
<b>Pollutant</b>	<b>Precision Checks completed</b>	<b>Precision Checks within limits</b>
Lead	98%	98%
PM <sub>10</sub>	100%	97%
PM <sub>2.5</sub>	97%	98%

### Flow rate bias

Results of the annual flow rate audits conducted by ARO personnel are shown in Figure 3, below. The center line for each pollutant represents the average bias across all sampler (i.e., with all sampler weighted equally). The lower and upper probability limits represent the boundaries within which 95 percent of the individual bias values are expected to be distributed.

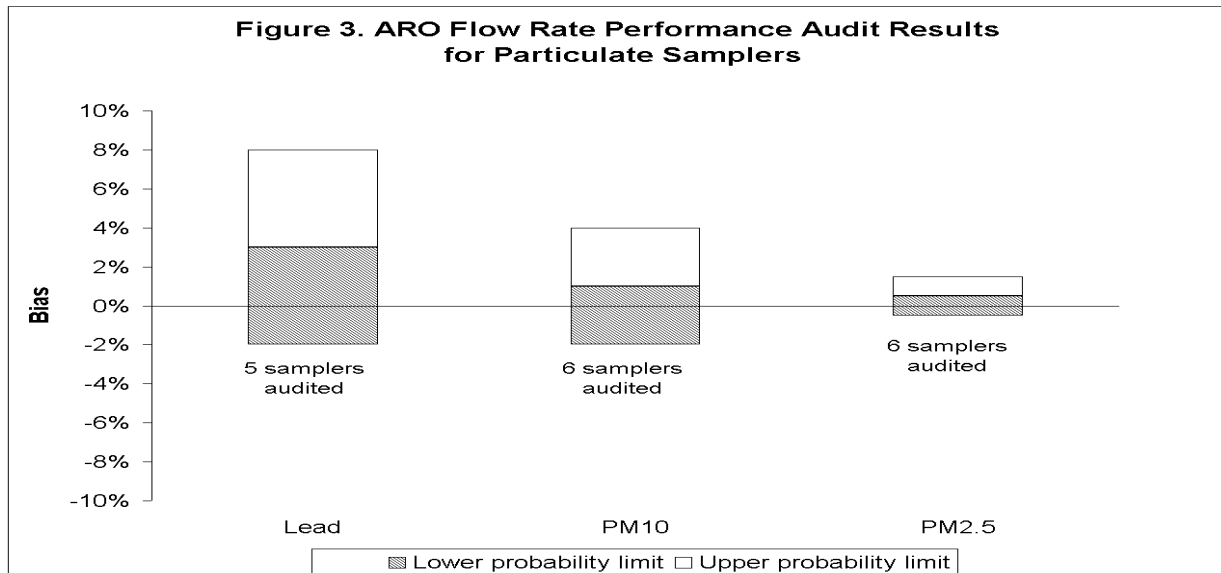
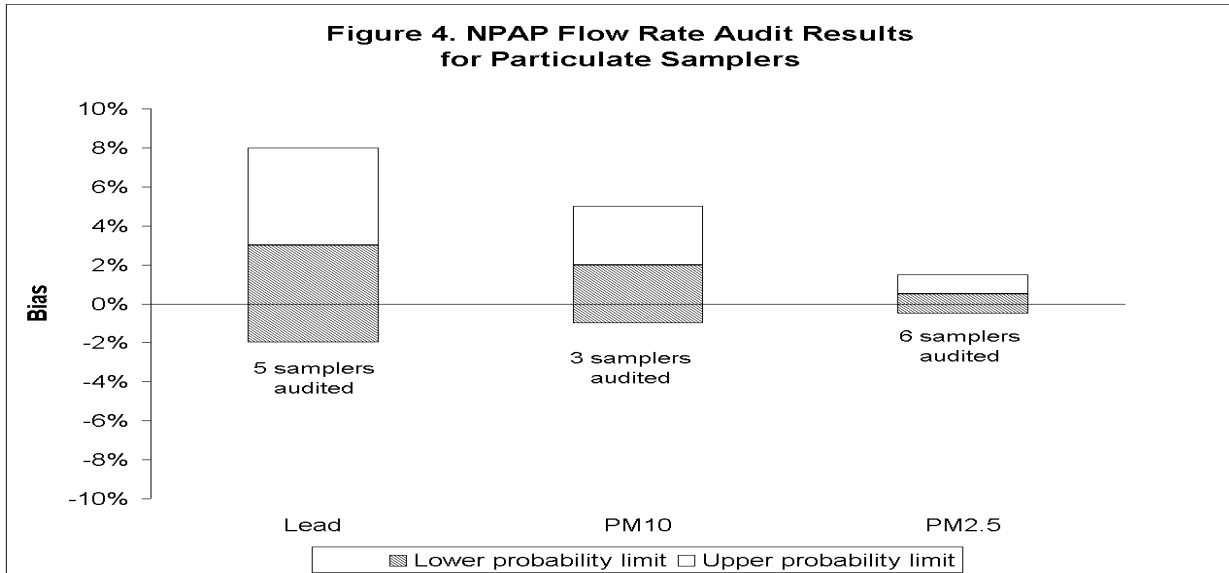

Figure 4 shows the results of external flow rate audits for PM<sub>10</sub> and lead samplers performed with the National Performance Audit Program (NPAP) which is administered by the U.S. EPA. Currently NPAP audits of PM<sub>2.5</sub> samplers involve sampler collocation rather than flow rate checks





### Measurement Bias

Measurement bias is evaluated for PM<sub>2.5</sub> analyzers by collocated sampling using an audit sampler. For internal audits, the collocated measurements provide an estimate of bias resulting from sampler operations. For external NPAP audits, the collocated measurements provide an estimate of bias resulting from both sampler and laboratory operations. Measurement bias for lead is evaluated by use of standard lead test samples. This provides an estimate of the bias resulting from laboratory operations. The results of the annual performance audits of PM<sub>2.5</sub> and lead conducted by ARO personnel are shown in Figure 5, below.

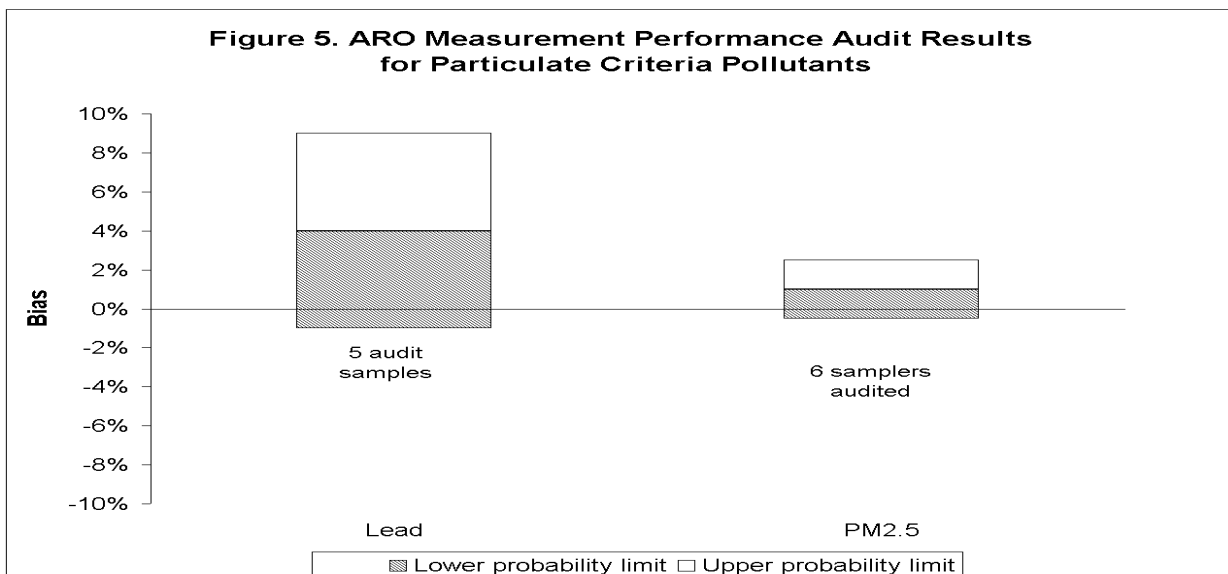
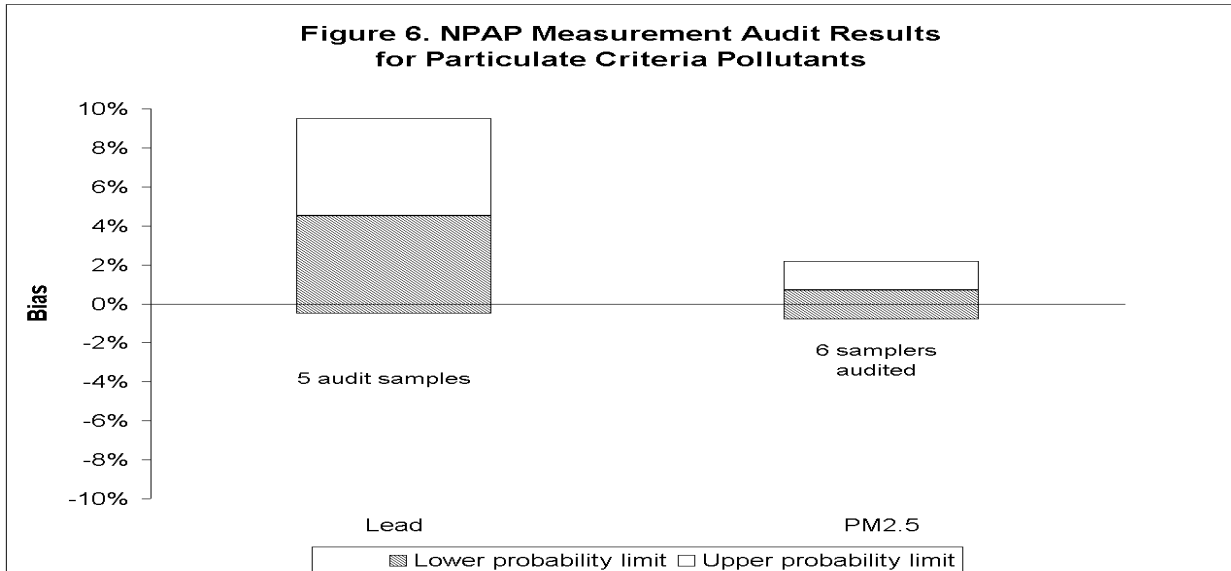

Figure 6 shows the results of external performance audits for PM<sub>10</sub> and lead performed with the National Performance Audit Program (NPAP) which is administered by the U.S. EPA.



## System Audits

Systems audits were performed at approximately one fourth of the sites and at the central analytical laboratory during calendar year 2000. These audits evaluated areas such as siting criteria, equipment operation and maintenance, operator training, recordkeeping, and served as a general review of site operations. No significant problems were observed, except for the following:

- The Towntwo site was shadowed by a 20 story office building which was recently completed. This site was closed in July 2000.
- The Townfour site had problems with repeated vandalism. A new, more secure, fence was installed in April and the sheriff's department increased patrols in the area to prevent reoccurrences.

No significant problems were found in the laboratory audits, except for failure to keep maintenance logs on several newly acquired analytical instruments. New logs were obtained and personnel instructed on their use. A spot check, approximately one month later, indicated the logs were in use.

## TOTAL AND SPECIATED VOLATILE ORGANIC COMPOUNDS (PAMS)

The Acme Reporting Organization monitors the ambient concentrations of ozone precursors (volatile organic compounds [VOCs], carbonyls, and nitrogen oxides that can produce the criteria pollutant ozone). This monitoring is conducted as part of the Photochemical Assessment Monitoring Stations (PAMS) network. Nitrogen dioxide (one of the nitrogen oxides measured in PAMS) is also a criteria pollutant and its measurement is described under the gaseous criteria pollutant section, above. Total nitrogen oxides (NO<sub>x</sub>) measurements are obtained continuously by a network of automated stations. Volatile organic compounds (VOCs), excluding carbonyls, are measured by continuous analyzers (on-line gas chromatographs) at selected sites. The remaining sites use automated samplers to collect VOC canister samplers which are then transported to the laboratory for analysis. Carbonyls are collected in adsorbent sampling tubes, which are transported to the laboratory for analysis.

### PROGRAM UPDATE

At the beginning of 2000, the Acme Reporting Organization operated 5 ambient air monitoring stations that measured ozone precursors. On March 1, 2000, a station was opened at Townone to monitor VOCs, carbonyls, and NO<sub>x</sub>.

### QUALITY OBJECTIVES FOR MEASUREMENT DATA

The Quality Objectives for the Acme Reporting Organization's ambient air monitoring of ozone precursors are shown in Table 9, below.

<b>Table 9. Quality Objectives for Ozone Precursors</b>	
<b>Data Quality Indicator</b>	<b>Objective</b>
Precision (NO <sub>x</sub> )	± 10%
Precision (VOC, Carbonyls)	± 25%
Bias (NO <sub>x</sub> )	± 15%
Bias (VOC, Carbonyls)	± 20%
Completeness	75%
Promptness	100%

### DATA QUALITY ASSESSMENT

#### Summary

Assessment of the data quality for ozone precursors showed that all instruments met goals for accuracy, precision, completeness, and promptness. System audits showed siting problems at two sites, both of these were corrected promptly.

## Promptness and Completeness

At least 75 percent of scheduled monitoring data must be reported. All data must be submitted within six months after the end of the reporting quarter. Table 10 summarizes promptness and completeness data for ozone precursors.

<b>Table 10. Data Quality Assessment for Promptness and Completeness</b>		
<b>Ozone precursor</b>	<b>Promptness</b>	<b>Completeness</b>
Carbonyls	100%	80%
Nitrogen Oxides (NO <sub>x</sub> )	100%	96%
Total VOCs (Total non-methane hydrocarbons)	100%	87%
Speciated VOCs	100%	83%

## Precision

At least once every two weeks, precision for nitrogen oxides (NO<sub>x</sub>) and automated VOC analysis were determined by sampling a gas of known concentration. Precision for manual VOC sampling and carbonyl sampling is obtained by analysis of duplicate samples. Duplicates are taken at a frequency of one duplicate for every 10 samples. Table 11 summarizes the precision check results for 2000.

<b>Table 11. Data Quality Assessment for Precision</b>		
<b>Ozone precursor</b>	<b>Precision checks completed</b>	<b>Precision checks within limits</b>
Carbonyls	91%	90%
Nitrogen Oxides (NO <sub>x</sub> )	98%	97%
Total VOCs (Total non-methane hydrocarbons)	90%	91%
Speciated VOCs	95%	80%

## Bias

The results of the annual performance audits conducted by ARO personnel are shown in Figure 7, below. For NO<sub>x</sub> and the automated VOC analyzers, the center line represents the average bias across all sites (i.e., with all sites weighted equally). For the carbonyl and manual VOC analyses, the center line represents the average of all audit samples for the central analytical laboratory. The lower and upper probability limits represent the boundaries within which 95 percent of the individual bias values are expected to be distributed. Carbonyl and Total VOC measurements represent the average of all audit species.

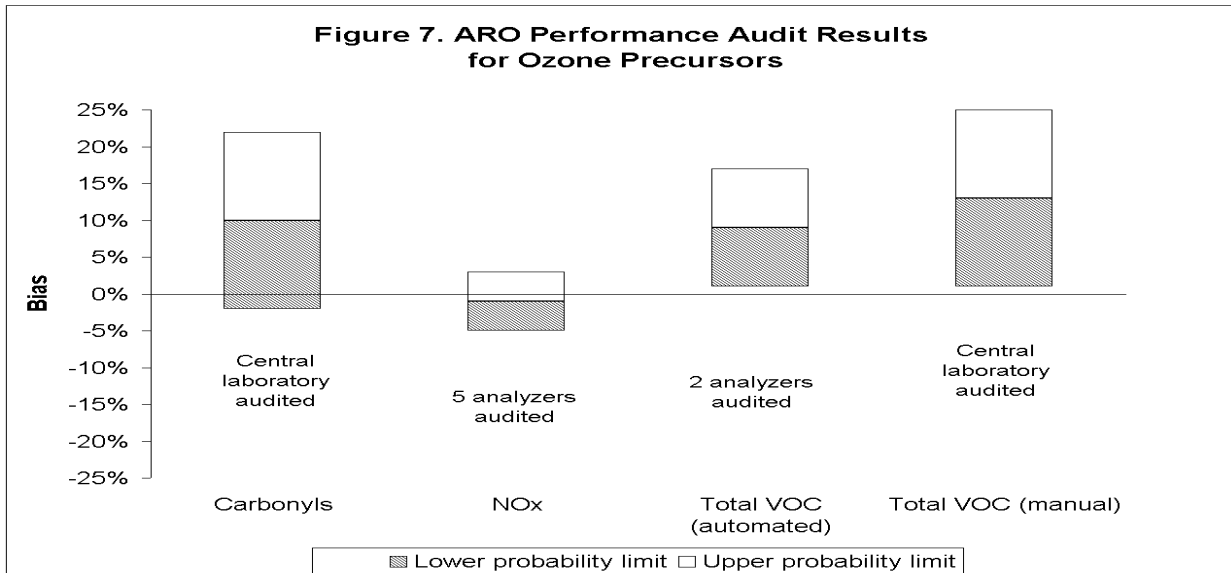
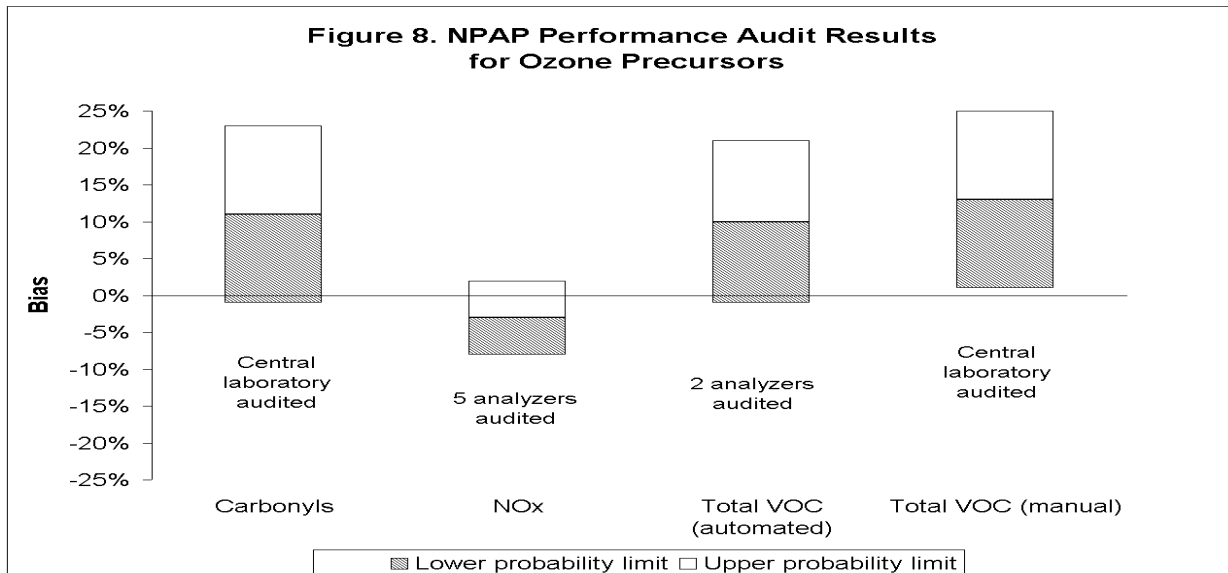

Figure 8 shows the results of the external performance audits performed with the National Performance Audit Program (NPAP) which is administered by the U.S. EPA.



### System Audits

Systems audits were performed at two sites during calendar year 2000. These audits evaluated areas such as siting criteria, analyzer and sampler operation and maintenance, operator training, recordkeeping, and serve as a general review of site operations. In general both sites were performing well except for the following:

- The Townsix site had vegetation which had grown too close to the analyzer inlet probes. The vegetation was removed within one week, with assistance from the County Parks and Recreation Department.

A systems audit was also performed at the central analytical laboratory. Results were good with only minor items noted for improvements.

## AIR TOXICS

The Acme Reporting Organization monitors the ambient concentrations of air toxic compounds. Three different methods are used, depending on the class of air toxic compound. Volatile organic compounds (VOCs), excluding carbonyls, are measured by continuous analyzers (on-line gas chromatographs) at selected sites. The remaining sites use automated samplers to collect VOC canister samplers which are then transported to the laboratory for analysis. Carbonyls are collected with adsorbent sampling tubes, which are transported to the laboratory for analysis. Inorganic compounds are collected on PM<sub>2.5</sub> filters (as part of particulate criteria pollutant monitoring) and analyzed (after weighing for PM<sub>2.5</sub> mass) by inductively coupled plasma mass spectrometry (ICP MS). This monitoring is conducted as part of the Air Toxics monitoring network.

### PROGRAM UPDATE

At the beginning of 2000, the Acme Reporting Organization operated five ambient air monitoring stations that measured ambient air toxics. On March 1, 2000, a station was opened at Townone to monitor air toxics.

### QUALITY OBJECTIVES FOR MEASUREMENT DATA

The Quality Objectives for the Acme Reporting Organization's ambient air monitoring of ambient air toxics are shown in Table 12, below.

<b>Table 12. Quality Objectives for Air Toxics</b>	
<b>Data Quality Indicator</b>	<b>Objective</b>
Precision	±25%
Bias	±25%
Completeness	75%
Promptness	100%

### DATA QUALITY ASSESSMENT

#### Summary

Assessment of the data quality for ambient air toxics showed that all instruments met goals for accuracy, precision, completeness, and promptness. System audits showed siting problems at two sites, both of these were corrected promptly.

### Promptness and Completeness

At least 75 percent of scheduled monitoring data must be reported. All data must be submitted within six months after the end of the reporting quarter. Table 13 summarizes promptness and completeness for ambient air toxics monitoring data.

<b>Pollutant</b>	<b>Promptness</b>	<b>Completeness</b>
Carbonyls	100%	78%
Volatile organic compounds	100%	84%
Inorganic compounds	100%	87%

### Precision

At least once every two weeks, precision for automated VOC analysis is determined by sampling a gas of known concentration. Precision for manual VOC sampling, carbonyl sampling, and inorganic sampling is obtained by analysis of duplicate samples. Duplicates are taken at a frequency of one duplicate for every 10 samples. Table 14 summarizes the precision check results for 2000.

<b>Pollutant</b>	<b>Precision checks completed</b>	<b>Precision checks within limits</b>
Carbonyls	91%	90%
Volatile organic compounds	98%	97%
Inorganic compounds	90%	91%

### Bias

The results of the annual performance audits conducted by ARO personnel are shown in Figure 9, below. For the automated VOC analyzers, the center line represents the average bias across all sites (i.e., with all sites weighted equally). For the carbonyl, manual VOC, and inorganic analyses, the center line represents the average of all audit samples for the central analytical laboratory. The lower and upper probability limits represent the boundaries within which 95 percent of the individual bias values are expected to be distributed. All measurements represent the average of all audit species.



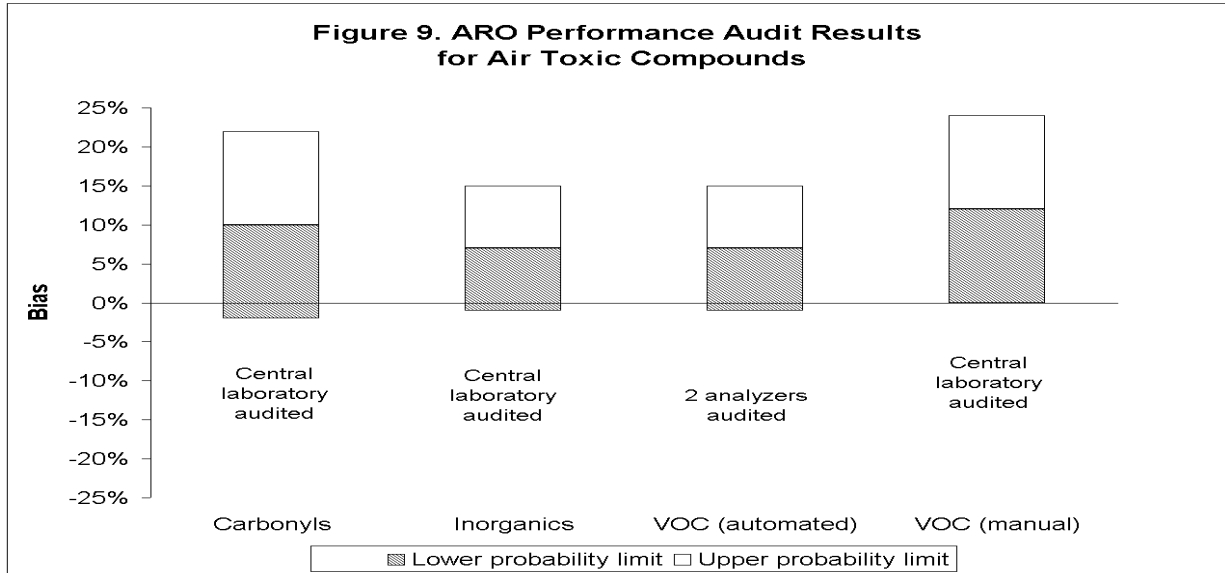
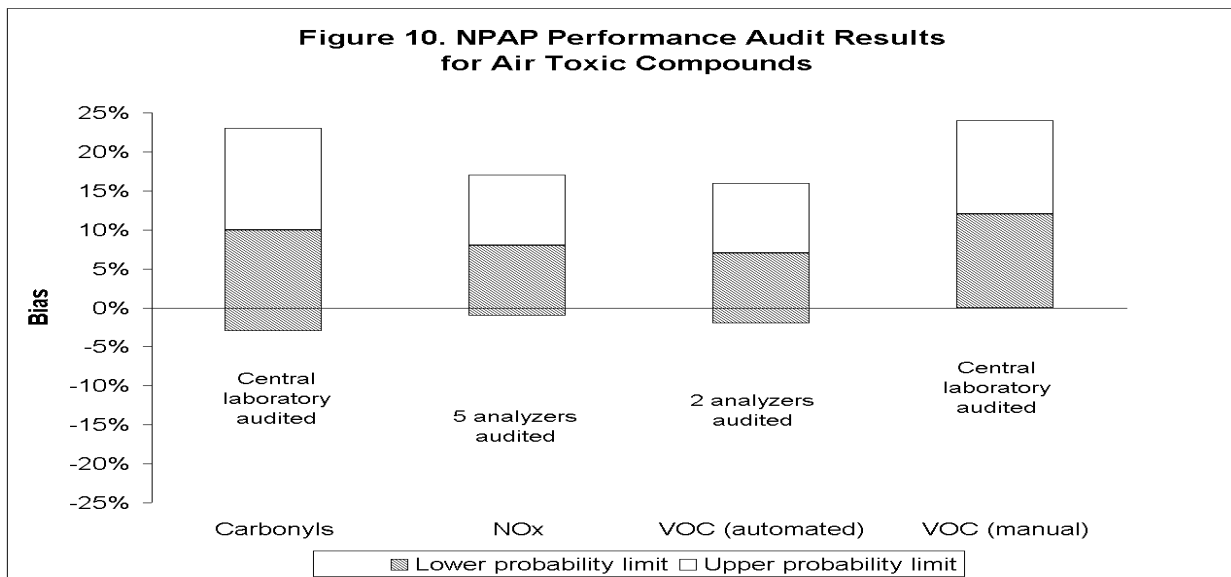

Figure 10 shows the results of the external performance audits performed with the National Performance Audit Program (NPAP) which is administered by the U.S. EPA.



## **System Audits**

Systems audits were performed at two sites during the calendar year 2000. These audits evaluated areas such as siting criteria, analyzer and sampler operation and maintenance, operator training, recordkeeping, and serve as a general review of site operations. No significant problems were found, except for the following:

- ▶ The Townsix site had vegetation which had grown too close to the analyzer inlet probes. The vegetation was removed within one week, with assistance from the County Parks and Recreation Department.

A systems audit was also performed at the central analytical laboratory. No significant problems were found.

## **Example of Corrective Action Form**

A corrective action request should be made whenever anyone in the reporting organization notes a problem that demands either immediate or long-term action to correct a safety defect, a operational problem, or a failure to comply with procedures. A typical corrective action request form, with example information entered, is shown below. A separate form should be used for each problem identified.

The corrective action report form is designed as a closed-loop system. First it identifies the originator, that person who reports and identifies the problem, states the problem, and may suggest a solution. The form then directs the request to a specific person (or persons), i.e., the recipient, who would be best qualified to "fix" the problem. Finally, the form closes the loop by requiring that the recipient state how the problem was resolved and the effectiveness of the solution. The form is signed and a copy is returned to the originator and other copies are sent to the supervisor and the applicable files for the record.

<b>ARO - Corrective Action Request</b>									
<b>Part A - To be completed by requestor</b>									
					<b>To:</b> <i>John S. Visor</i>				
<b>Organization Responsible for Action</b>					<i>ARO Ambient Air Monitoring Section</i>				
<b>Urgency:</b>									
<input type="checkbox"/> Emergency (failure to take action immediately may result in injury or property damage)									
<input type="checkbox"/> Immediate (4 hours)			<input checked="" type="checkbox"/> Urgent (24 hours)			<input type="checkbox"/> Routine (7 days)			
<input type="checkbox"/> As resources allow			<input type="checkbox"/> For Information only						
<b>From:</b> <i>William Operator</i>					phone: <i>(000) 555 - 1000</i>				
					fax: <i>(000) 555 - 1001</i>		e-mail: <i>billo@localhost</i>		
<b>Copies to:</b>									
<i>(Always send a copy to the ARO Site Coordinator at 115 Generic Office Building, Townone XX, 00001)</i>									
<b>Problem Identification</b>									
					Site(Location): <i>Townsix site</i>				
					System: <i>sample inlet</i>				
					Date problem identified: <i>Aug. 1, 2000</i>				
					Nature of problem: <i>Glass sample inlet and dropout trap broken during removal of weeds from site</i>				
<b>Recommended Action:</b> <i>Replace broken parts</i>									
					Signature: <i>William Operator</i>				
					Date: <i>Aug. 1, 2000</i>				
<b>Part B - to be completed by responsible organization</b>									
<b>Problem Resolution</b>									
					Date corrective action taken: <i>August 4, 2000</i>				
Summary of Corrective Action: <i>Replacement parts were ordered and received. The new parts were installed within three days of the request. Data from the days with a cracked sample inlet will be flagged as questionable.</i>									
					Effectiveness of corrective action: <i>Sample inlet restored to new condition.</i>				
					Signature: <i>John Visor</i>				
					Date: <i>Aug. 4, 2000</i>				
					Phone: <i>(000) 555 - 2000</i>				
					Fax: <i>(000) 555 - 2001</i>				
					e-mail: <i>jsv@localhost</i>				
<i>Send copies of the completed form to the requestor and the ARO Site Coordinator at 115 Generic Office Building, Townone XX, 00001)</i>									
ARO form CAR-1 , May 1, 1999									

---

United States  
Environmental Protection  
Agency

Office of Air Quality Planning and Standards  
Air Quality Assessment Division  
Research Triangle Park, NC

Publication No. EPA-454/B-08-003  
December, 2008

---

ATTACHMENT 2  
E-BAM OPERATIONAL MANUAL

# E-BAM

Rapid Deployment Particulate Monitor

## Operation Manual

For  $PM_{10}$  or  $PM_{2.5}$  Continuous Monitoring

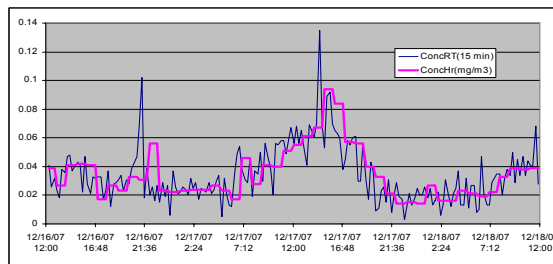

**Met One Instruments, Inc.**

1600 NW Washington Blvd • Grants Pass, Oregon 97526 • (541) 471-7111 • [www.metone.com](http://www.metone.com)

# **E-BAM PARTICULATE MONITOR OPERATION MANUAL**

**E-BAM-9800 REV L**



**Met One Instruments, Inc.**

1600 NW Washington Blvd.  
Grants Pass, OR 97526  
Telephone: (541) 471-7111  
Facsimile: (541) 471-7116  
[www.metone.com](http://www.metone.com)

**E-BAM Particulate Monitor Operation Manual** - © Copyright 2008 Met One Instruments, Inc. All Rights Reserved worldwide. No part of this publication may be reproduced, transmitted, transcribed, stored in a retrieval system, or translated into any other language in any form without the written permission of Met One Instruments, Inc.

# Table of Contents

<b>1</b>	<b>INTRODUCTION</b>	<b>4</b>
1.1	About This Manual .....	4
1.2	Technical Service.....	4
1.3	E-BAM: Environmental Beta Attenuation Monitor .....	4
1.4	Beta Radiation Safety Statement.....	5
1.5	The E-BAM and U.S. EPA Equivalent Methods.....	5
1.6	E-BAM Specifications .....	6
<b>2</b>	<b>E-BAM UNIT ASSEMBLY AND START-UP</b>	<b>7</b>
2.1	Assembling the E-BAM .....	7
2.2	Electrical Connections .....	9
2.3	Power-up and Automatic Operation.....	11
2.4	Power-up Settings Verification and Automatic Self-Test.....	11
2.5	Filter Tape Loading .....	14
2.6	Warm-up Period.....	15
<b>3</b>	<b>E-BAM USER INTERFACE and MENU SYSTEM</b>	<b>16</b>
3.1	The User Interface - Keypad and Display Functions.....	16
3.2	Using the Main Sampling Screen.....	17
3.3	Using Main E-BAM Menu System.....	18
<b>4</b>	<b>SAMPLE SITE SELECTION</b>	<b>21</b>
4.1	Site Selection Requirements.....	21
4.2	Fall Hazard and Security Cautions.....	22
4.3	Confined Sampling Locations .....	22
4.4	Smoke and Ash Monitoring.....	23
4.5	Remote Monitoring With Solar or Battery Power.....	23
<b>5</b>	<b>FIELD CALIBRATIONS AND FLOW CHECKS</b>	<b>25</b>
5.1	Leak Checks and Nozzle/Vane Cleaning.....	25
5.2	Ambient Temperature Sensor Audit.....	28
5.3	Ambient Barometric Pressure Sensor Audit.....	28
5.4	Flow Audits and Calibrations .....	29
5.5	Filter RH Sensor Audit .....	31
5.6	Filter Temperature Sensor Audit.....	31
5.7	Pump Tests.....	32
5.8	Analog Output Audits .....	33
5.9	Span Membrane Tests.....	34
<b>6</b>	<b>THE E-BAM MEASUREMENT CYCLE</b>	<b>36</b>
6.1	The Hourly Measurement Cycle.....	36
6.2	The Real-Time Average Measurement Cycle .....	37
6.3	Comparing the Hourly and Real-Time Values.....	40
<b>7</b>	<b>SETUP MENU DESCRIPTIONS</b>	<b>41</b>
7.1	The Clock Setup Screen .....	41
7.2	The Tape Advance and Real-Time Average Setup Screen .....	41
7.3	The MACHINE TYPE PM <sub>10</sub> /PM <sub>2.5</sub> Setup Screen .....	42
7.4	The Analog Output Setup Screen .....	43
7.5	The Serial Port Setup Screen .....	43
7.6	The RH Control Setup Screen .....	44
7.7	The Flow Rate and Flow Type Setup Screen .....	44
7.8	The Ambient RH Sensor Setup Screen .....	45
7.9	The Pump Protection Setup Screen.....	46



7.10	The Restart Voltage Setup Screen .....	46
7.11	The STANDARD Temperature Setup Screen .....	47
7.12	The Span Membrane Setup Screen.....	47
<b>8</b>	<b>MAINTENANCE and TROUBLESHOOTING</b>	<b>48</b>
8.1	E-BAM Error Displays, Error Logs, and Error Codes .....	48
8.2	Contact Closure Alarm Relay Output.....	51
8.3	Basic Problem and Cause/Solution Table.....	52
8.4	Met One Suggested Periodic Maintenance.....	54
8.5	DC Pump Replacement .....	55
8.6	Cleaning the Inside of the Sample Nozzle Assembly.....	56
8.7	Cleaning the Beta Detector Assembly .....	57
<b>9</b>	<b>DATA RETRIEVAL and COMMUNICATIONS</b>	<b>59</b>
9.1	Analog Voltage Output.....	59
9.2	Serial Port Connections to a Computer.....	59
9.3	Comet™ Data Retrieval Software .....	60
9.4	Downloading Data Using HyperTerminal or other Terminal Programs .....	60
9.5	“AutoMet” Data Retrieval Commands Through the Serial Port .....	61
9.6	Advanced Communications – Escape Commands .....	63
9.7	Modem Options for Remote Data Retrieval .....	63
9.8	Flash Firmware Upgrades.....	64
<b>10</b>	<b>ACCESSORIES and PARTS</b>	<b>65</b>
10.1	Consumables, Replacement Parts, and Accessories .....	65
<b>11</b>	<b>THEORY OF OPERATION and MATHEMATICAL ANALYSIS</b>	<b>69</b>
11.1	Converting Data Between EPA Standard and Actual Conditions.....	71
<b>12</b>	<b>SPECIAL E-BAM CONFIGURATIONS</b>	<b>72</b>
12.1	External Pump Box Configurations for the E-BAM.....	72
12.2	AIRSIS Satellite Uplink Option.....	73
<b>13</b>	<b>E-BAM AUDIT SHEET</b>	<b>74</b>

# 1 INTRODUCTION

## 1.1 About This Manual

This document is organized with the most important information toward the front of the manual, such as site selection, installation, setups, and field calibrations, which all E-BAM owners and operators should read and understand. Toward the back are sections that provide in-depth information on subjects such as theory, diagnostics, accessories, and alternate settings. These sections provide valuable information which should be consulted as needed. Electronic versions of this manual are also available.

## 1.2 Technical Service

This manual is structured by customer feedback to provide the required information for setup, operation, testing, maintaining, and troubleshooting your E-BAM unit. Should you still require support after consulting your printed documentation, we encourage you to contact one of our expert Technical Service representatives during normal business hours of 7:00 a.m. to 4:00 p.m. Pacific Standard Time, Monday through Friday. In addition, technical information and service bulletins are often posted on our website. Please contact us and obtain a Return Authorization (RA) number before sending any equipment back to the factory. This allows us to track and schedule service work and to expedite customer service.

Phone: (541) 471-7111

Fax: (541) 471-7116

E-Mail: [service@metone.com](mailto:service@metone.com)

Web: [www.metone.com](http://www.metone.com)

Address: Technical Services Department  
Met One Instruments, Inc.  
1600 NW Washington Blvd.  
Grants Pass, OR 97526

## 1.3 E-BAM: *Environmental Beta Attenuation Monitor*

The Met One Instruments, Inc model E-BAM automatically measures and records airborne PM<sub>10</sub> or PM<sub>2.5</sub> particulate concentration levels using the principle of beta ray attenuation. This method provides a simple determination of concentration in units of milligrams of particulate per cubic meter of air. A small <sup>14</sup>C (Carbon 14) element emits a constant source of high-energy electrons known as beta particles. These beta particles are detected and counted by a sensitive scintillation detector. A vacuum pump pulls a measured amount of dust-laden air through the filter tape, which is positioned between the source and the detector thereby causing an attenuation of the beta particle signal. The degree of attenuation of the beta particle signal is used to determine the mass concentration of particulate matter on the filter tape, and the volumetric concentration of particulate matter in ambient air. An in-depth scientific explanation of the theory of operation and the related equations is included toward the back of the manual. Complete descriptions of the measurement cycles are found in Section 6.

The E-BAM is designed as a simple, compact, and self-contained beta gauge, for portable applications where rapid deployment and short interval real-time measurements are required.

## 1.4 Beta Radiation Safety Statement

The Met One Instruments E-BAM contains a small  $^{14}\text{C}$  (Carbon 14) beta radiation-emitting source. The nominal activity of the source is  $60 \mu\text{Ci} \pm 15 \mu\text{Ci}$  (microcurries), which is below the “Exempt Concentration Limit” as defined in 10 CFR Section 30.71 – Schedule B. The owner of an E-BAM is not required to obtain any license in the United States to own or operate the unit. The owner of an E-BAM may elect to return the entire unit to Met One Instruments for recycling of the  $^{14}\text{C}$  source when the unit has reached the end of its service life, although the owner is under no obligation to do so. Under no circumstances should anyone but factory technicians attempt to remove or access the beta source. The beta source has a half-life of about 5730 years, and should never need to be replaced unless it becomes damaged or corroded. Neither the  $^{14}\text{C}$  source nor the beta particle detector are serviceable in the field. Should these components require repair or replacement, the E-BAM must be returned to the factory for service and recalibration. The E-BAM is manufactured in compliance with the U.S. NRC safety criteria in 10 CFR 32.27.

## 1.5 The E-BAM and U.S. EPA Equivalent Methods

The Met One Instruments, Inc. Model E-BAM is not currently designated as a U.S. EPA Federal Equivalent Method (FEM) for continuous  $\text{PM}_{10}$  or  $\text{PM}_{2.5}$  monitoring. However, the unit is designed to accurately predict FRM or FEM concentration measurements when operated in accordance with this manual. The E-BAM is intended as a rapid-deployment particulate monitor which can be used for emergency response situations, micro to neighborhood scale particulate studies, perimeter monitoring, remote monitoring, and other applications where a small, self-contained, portable unit is required. To that end, the E-BAM is unparalleled in its flexibility and ease of use.

The E-BAM is not intended to be used for permanent, long-term installations at a fixed monitoring site. This is an application for the Met One Instruments Model BAM-1020, which is an EPA designated FEM for both  $\text{PM}_{10}$  and  $\text{PM}_{2.5}$  monitoring, and is intended for continuous operation at a fixed site. Many agencies have networks which contain both types of Met One BAM units in order to meet their diverse sampling needs. The following table shows some of the features of the E-BAM compared to the BAM-1020:

	E-BAM	BAM-1020
Configurable for $\text{PM}_{2.5}$ , $\text{PM}_{10}$ , or TSP monitoring:	yes	yes
Compatible with EPA $\text{PM}_{10}$ inlets, cyclones, and WINS impactors:	yes	yes
U.S. EPA $\text{PM}_{2.5}$ and $\text{PM}_{10}$ Federal Equivalent Method:	no	yes
Portable unit designed for rapid deployment:	yes	no
Designed for continuous long-term operation at a fixed site:	no	yes
Hourly concentration measurements:	yes	yes
Hourly concentration accuracy:	good	best
Quasi real-time concentration output available:	yes	no
Analog and digital data outputs available:	yes	yes
16.7 lpm actual or standard flow rate:	yes	yes
Separate weatherproof shelter or enclosure required:	no	yes
Automatic hourly span checks:	no	yes
12 volt DC operation for remote sampling:	yes	no
Meteorological sensor inputs:	yes	yes
Sample RH control:	yes	yes
Filter tape advances:	variable	hourly
Operation time per standard filter tape roll:	variable	60 days

## 1.6 E-BAM Specifications

PARAMETER	SPECIFICATION*
<b>Measurement Principle:</b>	Particulate Concentration by Beta Attenuation.
<b>U.S. EPA Designations:</b>	Designed to meet Class III monitoring criteria. Not an EPA-designated FEM.
<b>Measurement Range:</b>	-0.005 to 65.530 mg/m <sup>3</sup> (-5 to 65,530 µg/m <sup>3</sup> ) 16 bit digital range.
<b>Accuracy:</b>	± 10% of indicated value for hourly measurements.
<b>Data Resolution:</b>	1 µg/m <sup>3</sup>
<b>Lower Detection Limit:† (2σ, 1 hour measurement)</b>	Less than 6.0 µg/m <sup>3</sup>
<b>Lower Detection Limit:† (2σ, 24 hour average)</b>	Less than 1.2 µg/m <sup>3</sup>
<b>Sample Time:</b>	Continuous air sampling with variable filter change periods.
<b>Measurement Cycles:</b>	Automatic hourly concentration measurements, with user selectable 1, 5, 10, 15, 30, or 60 minute quasi-real-time average output.
<b>Flow Rate:</b>	16.7 liters/minute. Adjustable up to 17.5 lpm. Actual or Standardized flow modes.
<b>Flow Accuracy:</b>	±2% of setpoint typical.
<b>Pump Type:</b>	Internal DC dual-diaphragm pump standard. 4000 hour rated.
<b>Filter Tape:</b>	Continuous glass fiber filter, 30mm x 21m roll. Up to 1 year operation per roll.
<b>Span Check:</b>	Manual 800ug (typical) span foil included.
<b>Beta Source:</b>	<sup>14</sup> C (carbon-14), 60 µCi ±15 µCi (< 2.22 X 10 <sup>6</sup> Beq), Half-Life 5730 years.
<b>Beta Detector Type:</b>	Photomultiplier tube with patented scintillator assembly.
<b>Operating Temp. Range:</b>	-25 to +50°C intermittent. -25 to +40°C continuous.
<b>Ambient Humidity Range:</b>	0 to 90% RH, non-condensing.
<b>Humidity Control:</b>	Automatic 15 Watt inlet heater module.
<b>Approvals:</b>	CE, NRC, ISO-9001
<b>User Interface:</b>	Menu-driven interface with 4x20 character VFD display and dynamic keypad.
<b>Analog Voltage Output:</b>	0-1, 0-2.5, or 0-5 volt DC output equals 0-1000 µg/m <sup>3</sup> . Selectable to represent the hourly or real-time concentration.
<b>Serial Interface:</b>	RS-232 2-way serial port for PC, datalogger, or modem communications.
<b>Alarm Contact Closures:</b>	Normally closed contact closure relay output. 0.5A @ 100V DC max.
<b>Compatible Software:</b>	Comet™ (included), Air Plus™, terminal programs such as HyperTerminal®
<b>Error Reporting:</b>	Available through serial port, display, and relay output.
<b>Memory:</b>	4369 records (182 days @ 1 record/hr. 3 days @ 1 record/min).
<b>Power Supply:</b>	12 to 16 Volt DC input. 4.1 amps @12 VDC (50 Watts) max continuous draw.
<b>Weight:</b>	13.2 kg (29 lbs) E-BAM only. 23 kg (50 lbs) with tripod, PM10, 9250, power supply.
<b>Unit Dimensions:</b>	41cm high x 36cm wide x 20cm deep. (16" x 14" x 8").

\* Specifications may be subject to change without notice.

† The hourly detection limit is defined as twice the standard deviation of the hourly zero noise of the instrument. The 24 hour detection limit is defined as the hourly detection limit divided by the square root of 24 (approx 4.9).

## 2 E-BAM UNIT ASSEMBLY AND START-UP

This section describes assembly, start-up, and filter tape installation for the E-BAM unit.

### 2.1 Assembling the E-BAM

The standard DC version of the E-BAM is designed to be field deployable by an average person in less than 15 minutes under normal conditions. Refer to the photos and diagrams below while performing the following steps to assemble the unit:

1. **Deploy the tripod:** Remove the three stainless steel detent pins from the tripod base by pulling the rings. Unfold the three tripod legs and reinsert the three pins so that each pin secures a leg in the open position. Make sure the erected tripod is rigid and stable.

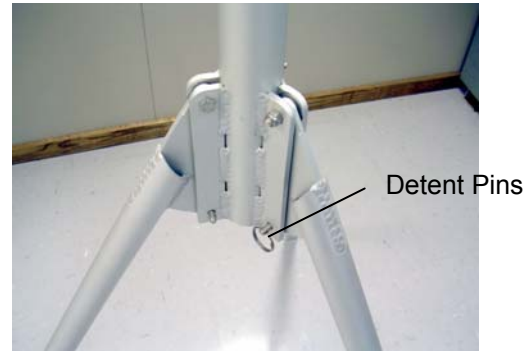

2. **Install the E-BAM onto the tripod:** Lift the E-BAM assembly and slide the slot on the back of the E-BAM over the tab on the top of the tripod. Insert the supplied  $\frac{1}{4}$ -20 bolt through the tab on the bottom of the E-BAM and through the hole in the body of the tripod. Secure it with the supplied washers and nut. This prevents the E-BAM from shifting on the tripod.
3. **Install the inlet tube and the PM<sub>10</sub> and PM<sub>2.5</sub> inlets:** Loosen the black weatherproof fitting on top of the E-BAM and insert the short inlet tube into the top of the unit. The tube must go through the black fitting and through two o-rings in the top of the E-BAM. *Make sure the tube is fully seated* by rotating it back and forth. Tighten the black weatherproof fitting to secure the inlet tube. For PM<sub>10</sub> monitoring, install the BX-802 PM<sub>10</sub> inlet directly onto the top of the short inlet tube. *If a BX-807 cyclone is to be used for PM<sub>2.5</sub> monitoring, it must be installed under the PM<sub>10</sub> head as shown in the picture below.* Lubricate the o-rings as necessary.

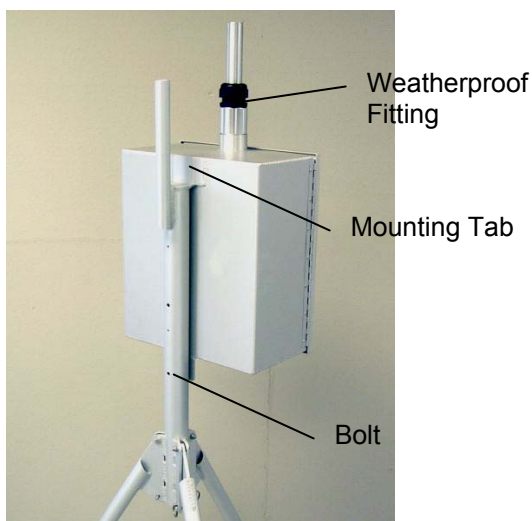

4. **Install the cross-arm and temperature sensor:** Connect the 18" cross-arm to the post on the back of the tripod with the supplied  $\frac{3}{4}$ " x  $\frac{3}{4}$ " fitting and set screws. The 9250 ambient temperature sensor snaps onto the cross-arm and plugs into the bottom of the E-BAM.



5. **Optional wind sensor:** If an optional EX-034 wind speed/direction sensor is supplied, then it will come with a longer cross-arm tube to use instead of the short one that came with the temp sensor. Install the wind sensor on one end of the cross-arm, and the temperature sensor on the other. The wind sensor should be as far from the E-BAM unit as possible, and the wind vane must be able to rotate fully without hitting anything. Plug the wind sensor into the corresponding connector on the bottom of the E-BAM. The sensor will need to be oriented to the north. Consult the separate manual that comes with the 034 wind sensor.
6. **Power Supply:** Many E-BAMs are supplied with an EX-121 AC-to-12<sub>VDC</sub> power supply as shown in the photo below. Bolt it to one of the legs of the tripod with the included U-bolts. Plug the power supply output cable into the DC power input on the bottom of the E-BAM. When the power supply is plugged into AC power, the E-BAM will turn itself on automatically. **Note:** If the E-BAM is to be powered by a battery array or solar system, or if the unit is supplied with an external AC pump box with a built-in power supply, then these items will plug into the E-BAM power input instead of the normal power supply.

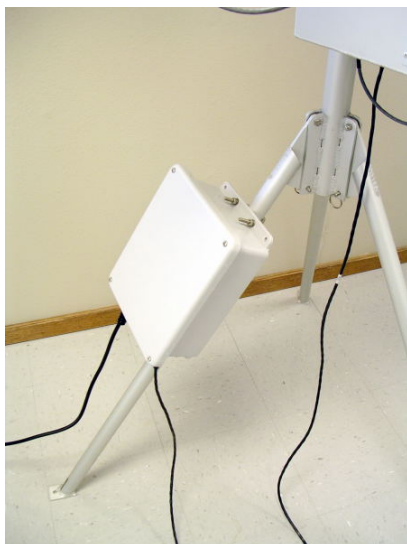

7. **Optional met sensors:** If the E-BAM is supplied with other optional met sensors such as ambient RH or barometric sensors, then these attach to the cross-arm and plug into the same connector as the temperature sensor, using a supplied splitter junction box.

## 2.2 Electrical Connections

The standard E-BAM has a set of weatherproof connectors on the bottom of the unit. These connectors provide the connections for the power supply, external sensors and communications options. Each connector has a different pin configuration to prevent plugging cables into the wrong connector. The E-BAM will turn on when a power source is connected to the power input. **Note:** There is a 3-color LED located on the bottom of the E-BAM near the electrical connectors. This LED may flash or hold various colors, but is used for factory test software applications only, and does not indicate any specific status information to the user.

The E-BAM chassis ground lug should be connected to an earth ground whenever possible, to reduce electrical noise in the unit.

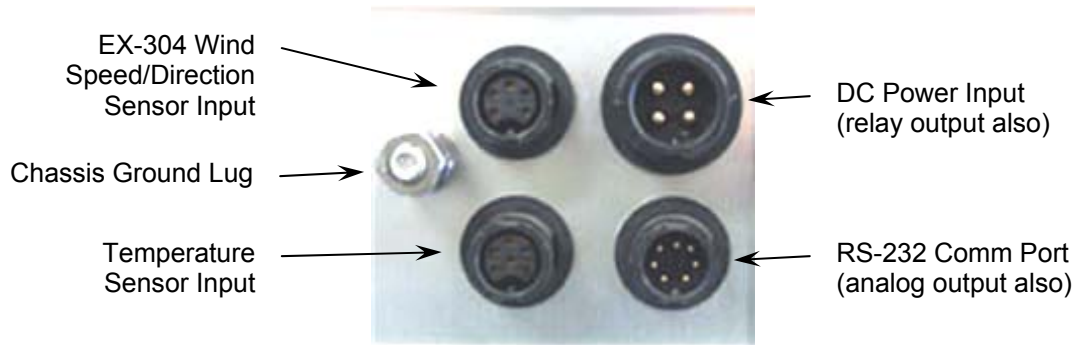

E-BAM connector layout

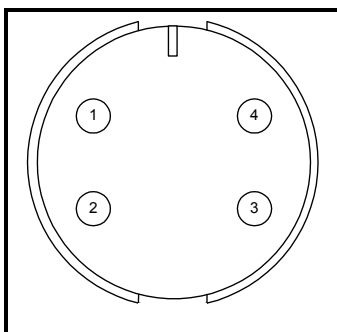

DC Power Input	
Pin	Function
1	+12 VDC Pwr Input
2	Ground/Common
3	Alarm Relay IN
4	Alarm Relay OUT

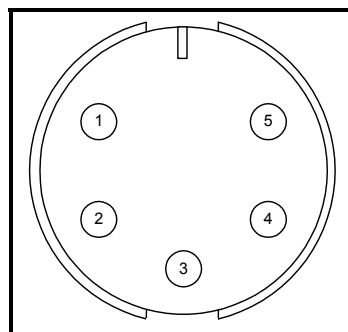

WS/WD Sensor In	
Pin	Function
1	Wind Direction Ref.
2	Ground/Common
3	Wind Direction Input
4	Wind Speed Input
5	Shield

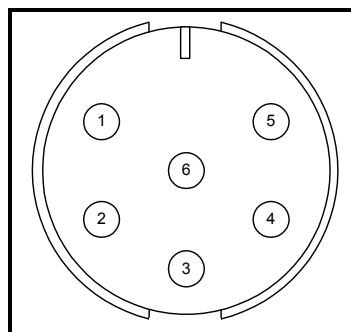

Temp Sensor Input	
Pin	Function
1	RH Signal Input
2	Ground/Common
3	+12 VDC Output
4	Temp Signal Input
5	Baro Signal Input
6	Shield

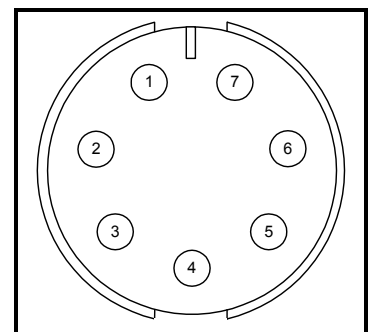

RS-232 Serial Port	
Pin	Function
1	RST
2	RX
3	TX
4	Ground/Common
5	STX
6	Analog Volt Output
7	TCK

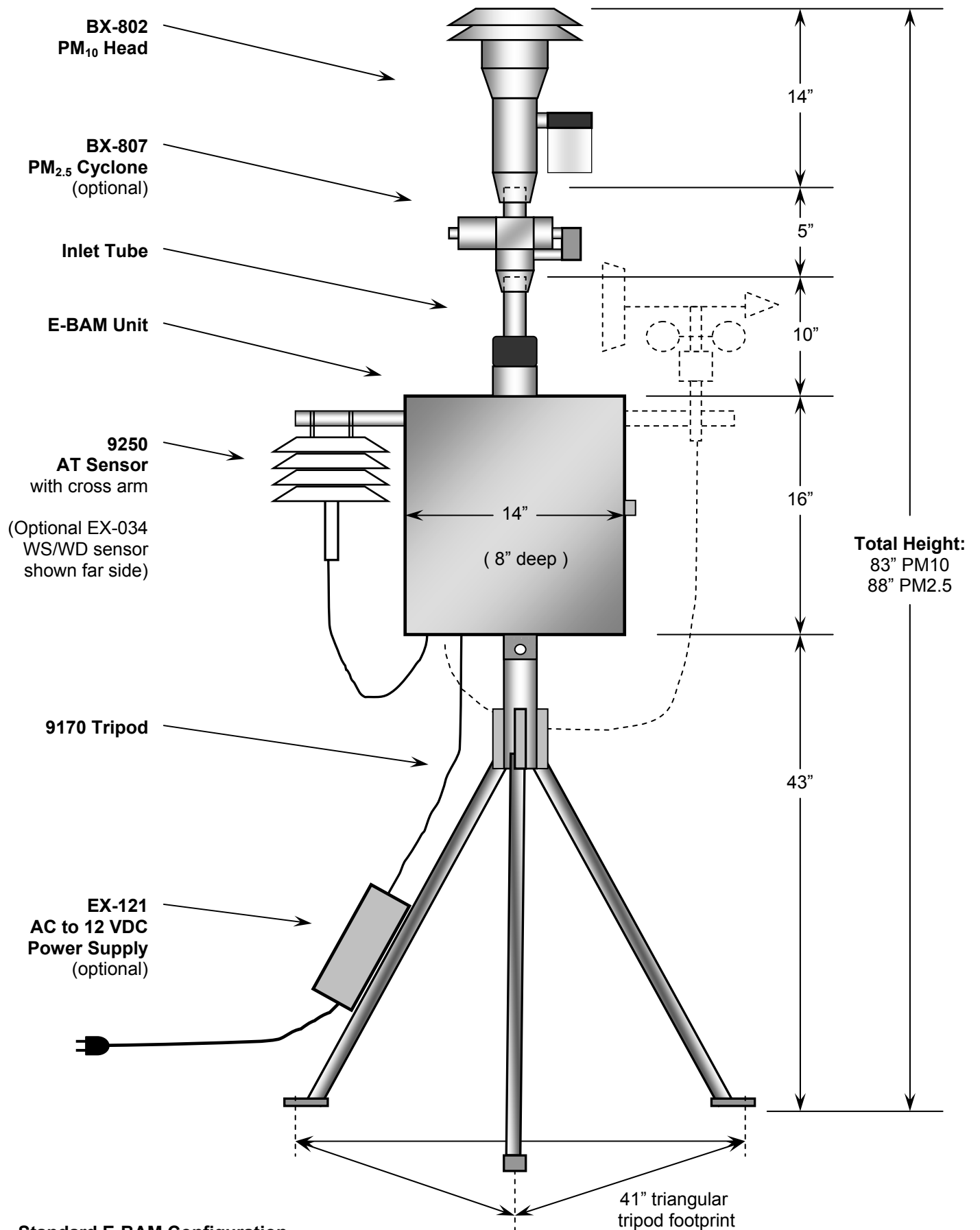

**Standard E-BAM Configuration**  
Not to scale. Some items simplified for clarity.



## 2.3 Power-up and Automatic Operation

The E-BAM is designed to turn on automatically when power is applied. The unit will ask if you are ready to start, then prompt you to verify several setup menus which are described below. Then the unit will perform an automatic self-test routine which takes several minutes. After the self-test, the unit will begin sampling automatically.

**Note:** *If no keypad activity is detected for several minutes after power-up, the E-BAM will automatically begin sampling based on the existing SETUP options and settings, as long as filter tape is installed and no hardware or voltage failures are detected. This makes it possible to fully configure and calibrate the unit in the lab, then simply deploy it to the field and power it up with no further actions required.*

## 2.4 Power-up Settings Verification and Automatic Self-Test

The E-BAM will prompt you to verify several setup parameters whenever it is powered on. These setup screens can also be viewed or edited in the SETUP menu under the main E-BAM menu system. See Section 7 for detailed descriptions of the SETUP parameters.

When power is applied to the E-BAM, the unit will show the firmware revision and unit serial number for a moment, then display the welcome screen:

```
WELCOME TO E-BAM
ARE YOU READY TO
START?
YES
```

Press the YES soft key, and the clock screen is displayed as shown below. If the time and date are correct, press the YES key. If you need to change the time or date, press NO and the display will show the time/date set screen. Use the arrow keys to change the values, then press SET. Or press CONTINUE to go on without making changes.

```
DATE : 19-NOV-2008
TIME : 16:36:37
IS THIS CORRECT?
NO YES
```

```
19-NOV-2008 16:36:42
SET CONTINUE
```

After the time is verified, the unit will display the AVERAGE PERIOD screen shown below. This menu is important to understand. See Sections 6.2 and 7.2 for detailed descriptions of these parameters. Press OK if the settings are correct. If the settings need to be changed, press the EDIT key to enter the edit mode. Select the parameter to be changed with the ◀▶ keys, and modify the settings with the ▲▼ keys and press SAVE. Press CONTINUE to exit the edit mode without making changes.

```

LOCATION: 01
TAPE ADVANCE: 24 HRS
REALTIME AVG: 10 MIN
EDIT          OK

```

```

LOCATION: 01
TAPE ADVANCE: ▼24 HRS
REALTIME AVG: ▼10 MIN
SAVE          CONTINUE

```

**LOCATION** is an ID number which will appear in the data array to indicate which unit collected the data, and to enable tracking of measurement information. This is used instead of a UNIT ID because the E-BAM is portable. This may be any number from 01 to 99.

**TAPE ADVANCE** is how often the E-BAM will automatically advance to a new spot of filter tape. This value can be set to 1, 2, 3, 4, 6, 8, 12, or 24 hours. The default setting is 24 hours for maximum tape life. The unit will override this setting and automatically advance the filter tape if the concentration is too high and the filter tape becomes clogged. If the filter tape is advanced due to high concentrations, an alarm will be recorded in the alarm log. **Note:** the tape advance setting does not change how often the concentration is calculated or stored.

**REALTIME AVG** is the averaging period for the real-time concentration value. The real-time concentration measurement is updated every minute, and the REALTIME AVG is the mean of these real-time values over the selected time period. The REALTIME AVG may be set to the following time periods: 1, 5, 10, 15, 30, or 60 minutes. This also sets the averaging period for the datalogger. See Sections 6.2 and 7.2 for important considerations regarding this setting.

After the real-time settings are verified, the E-BAM will go on to display the MACHINE TYPE screen. Press EDIT to change the setting with the arrow keys, or press OK to go on without changes:

```

MACHINE TYPE: PM10
< SEE PICTURE
EDIT          OK

```

**MACHINE TYPE** tells the E-BAM which type of inlet it is equipped with, PM<sub>2.5</sub> or PM<sub>10</sub>. *The only difference between the two is whether a PM<sub>2.5</sub> cyclone is installed or not.* The E-BAM will put the machine type setting onto the data array, so that you can tell if the collected data was PM<sub>2.5</sub> or PM<sub>10</sub>. The screen refers the user to a picture located inside the door of the E-BAM for easy identification of the two possible inlet types:

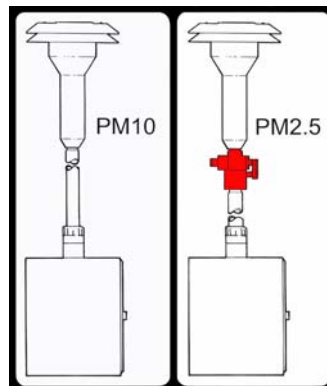

E-BAM Door Label for Inlet Identification

After the MACHINE TYPE is set or verified, the E-BAM will raise the nozzle and check to see if the stainless steel shipping shim is installed under the nozzle. **Note:** The shim is attached to the unit with a tether chain, and is also used for the zero portion of the span membrane test. The shim should be installed any time the E-BAM is shipped or transported in order to prevent nozzle damage. The unit can sense the shim with a photo sensor. If the shim is still in place the unit will display the message “PLEASE REMOVE NOZZLE PACKING MATERIAL”.

After the nozzle shim has been removed, the E-BAM will check if a roll of filter tape installed. If tape is already installed, the unit will go on to the power status screen. If no tape is detected, the unit will prompt you to install a new roll:

```
CHECKING FOR
LOADED TAPE .

PLEASE WAIT . . .
```

```
PLEASE LOAD TAPE !
E-BAM WILL NOT
OPERATE WITHOUT
TAPE !           CONTINUE
```

Install a roll of filter tape as described in Section 2.5. When the filter tape is installed, press CONTINUE. The unit will again try to detect the tape. If tape is detected, the unit will go on to display the power status screen. This is mostly useful if the unit is powered with batteries:

```
BATTERY: 14.3 VOLTS
ESTIMATED OPERATION
TIME FOR 100 AMP-HRS
IS 33 HRS.   CONTINUE
```

Press CONTINUE to proceed. The unit will begin the self-test process and will show “SELF TEST RUNNING...” on the display. The self-test takes several minutes and can only be bypassed by pressing the ESC key. The unit will test the nozzle, tape motor, beta detector, pump, flow sensor, and pressure sensors. If a fault is detected during the self-test, the hardware failure screen will be shown. Press CONTINUE to view the cause of the failure. See Section 8.1 for error descriptions. In the example below, the operator has forgotten to connect the 9250 ambient temperature sensor to the E-BAM. The unit has indicated that the sensor is not operational. If a hardware failure is detected, the problem must be corrected before proceeding. Press the MENU key to enter the menu system if needed. Other hardware failures that will hinder E-BAM operation include:

- Ambient or filter temperature sensor missing or failed.
- Ambient or filter pressure sensor failure.
- Broken or missing filter tape.
- Low battery voltage or DC input voltage below 10 volts DC.

```
WARNING
HARDWARE FAILURE

CONTINUE
```

```
25-NOV-2008 10:08:00
SENSOR FAILURE
Ambient Temp
-29.6
```

If the self-test finishes without errors, the screen will display that the unit is functioning properly. Press CONTINUE to go on to the start operation screen as shown below. Press YES to immediately start the E-BAM sampling on a normal operating cycle. Press MENU to forgo operation and enter the main E-BAM menu system instead.

SELF TEST COMPLETE:  
E-BAM FUNCTIONING  
PROPERLY .  
CONTINUE

WARNING  
START OPERATION?  
MENU YES

This is the end of the automatic E-BAM start-up sequence. It is recommended that you perform a leak check and flow check/calibration as described in Section 5. *Become comfortable with these checks, as they will be performed often.*

## 2.5 Filter Tape Loading

Filter tape must be loaded into the E-BAM for sampling. One roll of tape will last anywhere from a few weeks to more than a year, depending on the TAPE ADVANCE setting and ambient particulate levels. It is important to have several spare rolls of tape available to avoid data interruptions. Some agencies save used rolls of tape for post-sampling analysis, although there is no guarantee that the sampled spots have not been contaminated. Used filter tape should never be “flipped over” or re-used! This will result in measurement problems. Loading a roll of filter tape is a simple matter using the following steps:

1. If the sample nozzle is in the down position, it will need to be raised. Enter the LOAD TAPE screen in the main E-BAM menu. The unit will raise the nozzle and prompt you to load the tape.
2. If you are replacing a used roll of tape. Remove the old roll, then thoroughly clean the nozzle and vane as described in Section 5.1.
3. An empty core tube must be installed on the left (take-up) reel hub. This provides a surface for the used tape to spool-up on. Met One supplies a plastic core tube to use with the first roll of tape. After that, you can use the empty cardboard core tube left over from your last roll to spool-up the new roll. Never fasten the filter tape directly to the aluminum hub!
4. Load the new roll of filter tape onto the right (supply) reel, and route the tape through the nozzle area as shown below. Attach the loose end of the filter tape to the empty core tube with tape.
5. Rotate the tape roll to remove excess slack, then install the plastic spool covers **tightly**. The spool covers clamp the tape rolls to the hubs to prevent them from slipping.

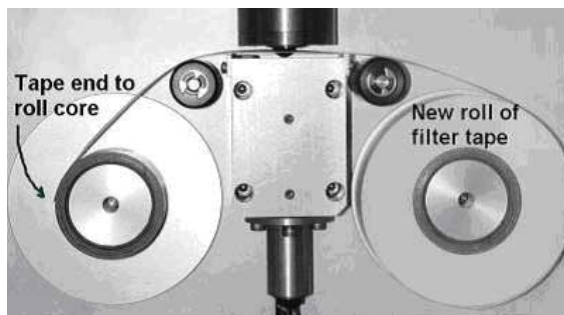

## **2.6 Warm-up Period**

The E-BAM must warm up for at least one hour before optimum accuracy of the concentration data can be obtained. This is because the beta detector contains a vacuum tube which must stabilize. This applies any time the unit is powered up after being off for more than a moment. Setups, tests, and flow calibrations can be performed during this warm up time. The first hour of data should often be discarded or ignored. Some agencies choose to discard the first few hours of concentration data after the E-BAM unit is powered up.

### 3 E-BAM USER INTERFACE and MENU SYSTEM

This section describes the E-BAM user interface system, and describes the functions of the main menu options, including how to view data and errors.

#### 3.1 The User Interface - Keypad and Display Functions

The E-BAM user interface consists of a 4x20 character vacuum fluorescent display (VFD) and a dynamic keypad. The two white keys under the display are called “soft keys”. These are dynamic keys which change in response to a menu option displayed directly above the key on the bottom row of the display. The function of these keys depends on which menu is shown on the display, and are often used for functions such as “save”, “edit”, and “set”.

The four red arrow (cursor) keys are used to scroll up, down, left, and right, to navigate in the menu system, and to select items or change fields on the screen. The arrow keys are also often used to change parameters or increment/decrement values in the menu system. The right arrow key can be used to wake up the display if it has turned off to save power.

The MENU/SELECT key is used to enter the main menu or to select an item in a list. The ESC key is used to escape or exit out of a menu.

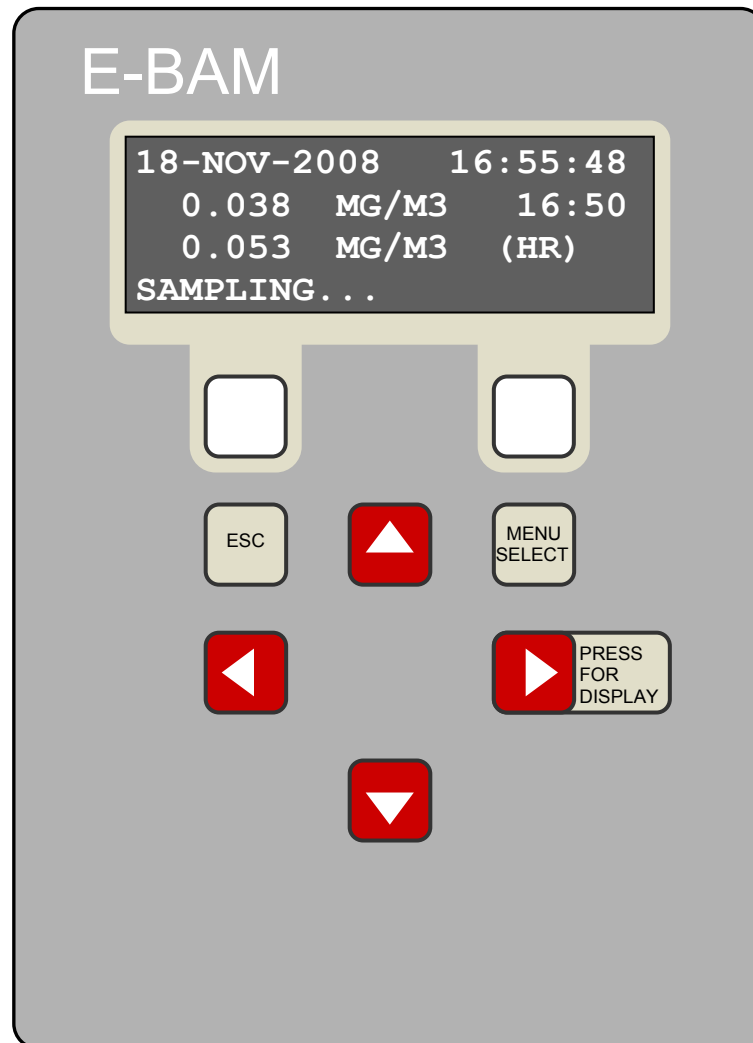

**E-BAM User Interface**

### 3.2 Using the Main Sampling Screen

The E-BAM display shows the Sampling screen when the unit is in normal operation. The active display area shows the current date and time, the latest real-time average concentration, and the last hourly concentration. Also shown is a status message, such as "SAMPLING...". To view the rest of the instantaneous sensor parameters which do not all fit on the display at once, press the down ▼ arrow. The date and time will remain at the top of the display at all times.

To view past data, use the left ◀ arrow key to scroll back to previous data records. There will be one complete data record for every real-time average interval, indicated by the time/data stamp at the top of the screen. For example, if the real-time average is set to 10 minutes, then there will be a complete data record stored every 10 minutes as shown below. Again, you can use the ▼ key to view the rest of the sensor parameters for that record. Press the ESC key at any time to return to the current concentration sampling screen.

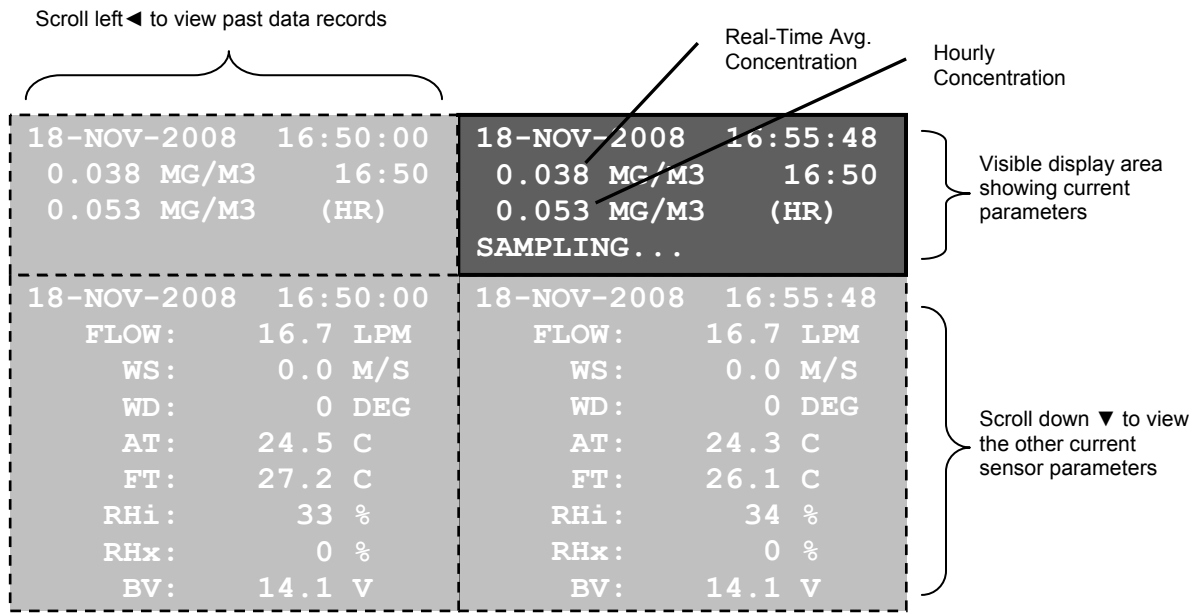

**Main Sampling Screen Format**

Below is a table which describes the other parameters visible in the main sampling display as shown above. In addition to the hourly and real-time average concentrations, these are all of the logged parameters in the E-BAM:

Parameter	Description
<b>FLOW</b>	Primary air flow rate in actual LPM or standard SLPM.
<b>WS</b>	Wind speed in meters per second (if equipped).
<b>WD</b>	Wind direction in degrees (if equipped).
<b>AT</b>	Ambient temperature in degrees C.
<b>FT</b>	Filter temperature in degrees C.
<b>RHi</b>	Internal filter RH.
<b>RHx</b>	External ambient RH (if equipped).
<b>BV</b>	Battery voltage (or DC input voltage).
<b>FLOW</b>	Secondary flow in LPM. Only appears if primary flow is set to SLPM.

### 3.3 Using Main E-BAM Menu System

The main E-BAM menu system can be entered at almost any time by pressing the MENU/SELECT key. Use the ▲▼ arrow keys to select the desired menu option, then press the MENU/SELECT key to enter the selected sub-menu. The functions in the FIELD CALIBRATION menu are described in Section 5. The functions in the SETUP menu are described in Section 7. All of the other main menu functions are described below.

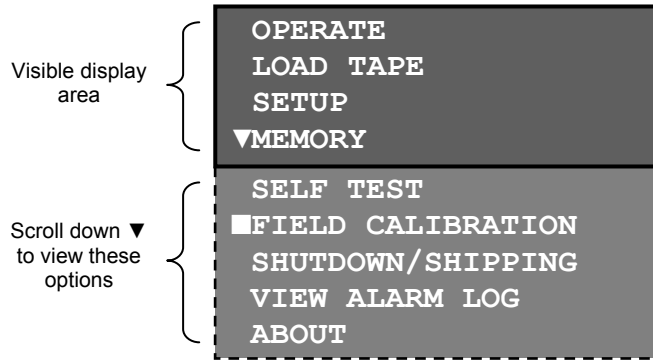

The Main E-BAM menu

**OPERATE:** This menu option starts the E-BAM into normal operation mode and starts a new sample cycle. You will see a message which says "WARNING: START OPERATION?" Press the YES key to start a new sample. If the unit is already sampling, this option will simply exit the main menu and display the main sampling screen.

**LOAD TAPE:** This menu option is used for filter tape installation. If this option is selected, the E-BAM will simply raise the sample nozzle for easy tape loading, then display "PLEASE LOAD TAPE." Load the tape and press the CONTINUE key to go back to the main menu.

**SETUP:** This is the setup menu for the E-BAM. All of the setup parameters in this menu are described in Section 7.

**MEMORY:** This menu option displays the amount of memory left in the E-BAM digital data system as shown below. To erase the memory, press the CLEAR key. Use the arrow keys to select either the DATA LOGGER or ALARM LOG to be cleared, then press the CLEAR key again. The unit will show a CAUTION screen. If you are sure you want to erase the selected log, press the YES key.

**CAUTION! Once the data log or the error log is cleared, the erased data can never be recovered.**

<pre> MEMORY 99 % REMAINING 30.3 DAYS REMAINING CLEAR                               EXIT         </pre>	<pre> CLEAR MEMORY CLEAR:▼DATA LOGGER CLEAR                               EXIT         </pre>	<pre> &gt;&gt;&gt;&gt; CAUTION &lt;&lt;&lt;&lt; CLEAR DATA LOGGER MEMORY? NO                               YES         </pre>
---	---	---

The unit contains memory for **4369** data records. The memory will fill up faster the shorter the real-time average interval is set to, as shown in the table below. This is another reason why the 1 and 5



minute RT averages are rarely used. **Note: When the memory is full, the unit over-writes the oldest data.**

Real-Time Average Setting	Records Stored Per Hour	Memory Capacity (Days)
1 min	60	3.03
5 min	12	15.1
10 min	6	30.3
15 min	4	45.5
30 min	2	91
60 min	1	182

**SELF TEST:** This menu option starts the E-BAM on an automatic self-test cycle, just like the self-test it performs when powered on. Press the ESC key to escape from the self-test and return to the main menu.

**FIELD CALIBRATION:** This is the field calibration menu for the E-BAM. All of the calibrations and tests in this menu are described in Section 5.

**SHUTDOWN / SHIPPING:** This menu option is used to prepare the E-BAM for transport. When you enter this screen, the nozzle will raise, and the display will show “PLEASE INSERT NOZZLE PACKING MATERIAL”. This is the empty zero membrane shim which is connected to the unit with a tether chain. This shim prevents damage of the nozzle during transport or shipment. Insert the shim under the nozzle with the tab extending through the slot. The E-BAM will automatically lower the nozzle onto the shim, then display: “OK TO TURN OFF E-BAM”. The power cord can now be unplugged to power off the E-BAM. **Note:** It is OK to power off the E-BAM at almost any time during normal operation. This menu simply allows the opportunity to insert the nozzle shim.

**VIEW ALARM LOG:** This menu option allows you to quickly view the error log entries in the E-BAM without having to download the digital data. The screen will display the type or error, as well as the time and date when the error occurred. Scroll through the error records using the ◀▶ arrow keys. Press the MENU/SELECT key to return to the main menu.

**ABOUT:** This menu option displays the E-BAM firmware version and revision, as well as the E-BAM serial number as shown in the example below. The up/down arrow keys may be pressed to change which firmware version is shown. The E-BAM has two separate firmware files. One is for the master CPU and the other is for the 3610 I/O control board. Press the MENU/SELECT key to return to the main menu.

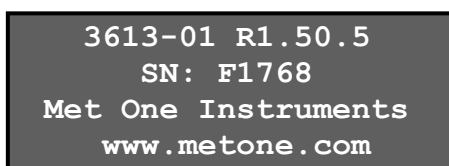

**Note:** If the ESC key is pressed while the E-BAM is displaying the ABOUT screen, the unit will prompt the user for a password. This is for entry into an advanced factory test menu. Do not enter this system unless instructed to do so by a Met One technician.

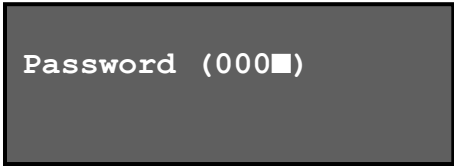

## 4 SAMPLE SITE SELECTION

Use the following criteria when deciding on a sampling location for the E-BAM. Always consider the safety and security of the unit as well as the suitability of the sampling environment.

### 4.1 Site Selection Requirements

Selection of a proper site for the E-BAM is critical for accurate measurements. In many cases, these items must be correctly addressed in order for the collected data to be acceptable for regulatory requirements, such as FEM, ARM or SPM methods. U.S. EPA Specifications for the site selection can be found in the EPA documents listed below:

- 40 CFR, Part 58 Appendix E.
- Quality Assurance Guidance Document 2.12 “*Monitoring PM<sub>2.5</sub> in Ambient Air Using Designated Reference or Class I Equivalent Methods*” Section 5.1.2.

The following is a summary of the primary site requirements. In any case, the Code of Federal Regulations takes precedence where applicable. Refer to the EPA website at [www.epa.gov](http://www.epa.gov).

#### Inlet Height:

- The inlet should be located in the “breathing zone”, between 2 and 15 meters above ground level. When installed on the standard tripod, the E-BAM PM<sub>10</sub> inlet is positioned just over two meters above the ground or other mounting surface. A PM<sub>2.5</sub> cyclone will add about five inches.
- If the inlet is located on (or through) a rooftop, the total height should be no more than 15 meters from the ground level.
- If the BAM-1020 is to be co-located with other particulate instruments, such as FRM filter-type samplers or other BAM units, then the air inlet must be the same height as the inlet of the other samplers, within one meter vertically. Within one foot is preferred.
- If the E-BAM inlet is the highest point on a building, then lightning rods must be installed to prevent destruction of the unit during electrical storms.

#### Inlet Radius Clearance:

- The E-BAM inlet must have a one meter radius free of any objects that may influence airflow characteristics, including the inlet of another instrument.
- If a E-BAM is to be co-located at a station with other BAM or FRM sampler, the inlets of each sampler must be no less than one meter apart from each other, and no more than four meters apart. Two meter spacing is recommended where possible.
- If installed near a PM<sub>10</sub> Hi-Volume sampler, then the distance between the inlet of the E-BAM and the Hi-Vol must be no less than two meters.
- The E-BAM inlet must be located away from obstructions such as short walls, fences, and penthouses, so that the inlet is unobstructed for two meters in all directions.
- If located beside a major obstruction (such as a building) then the distance between the E-BAM and the building must be equal to twice the height of the building.
- The inlet must be at least 20 meters from the drip line of any overhanging trees.
- There must be at least a 270 degree arc of unrestricted airflow around the inlet. The predominant direction of concentration movement during the highest concentration season must be included in the 270 degree arc.

### **Artificial Particulate Sources:**

To avoid possible errors in the concentration measurements, the inlet must be located as far as possible from any artificial sources of particulate, such as blowers, vents, or air conditioners on a rooftop. Especially if any of these types of devices blow air across the inlet of the E-BAM. Even sources of filtered air must not blow across the inlet.

### **Spacing from Roadways:**

The E-BAM should usually not be located directly next to a major highway or arterial roadway, as vehicle exhaust will dominate the concentration measurement. This effect can be difficult to predict accurately as shifting winds may direct the plume toward or away from the E-BAM inlet.

- Roads with a daily traffic volume of less than 3,000 vehicles are generally not considered major sources of pollutants, and in this case the E-BAM must be located at least five meters from the nearest traffic lane.
- The E-BAM must be located at least 25 meters from any elevated roadway greater than five meters high.
- The unit should be located as far as possible from unpaved roadways, as these also cause artificial measurements from fugitive dust.
- The unit should not be installed in unpaved areas unless year-round vegetative ground cover is present, to avoid the affects of re-entrained fugitive dust.

## **4.2 Fall Hazard and Security Cautions**

If the E-BAM is to be installed more than three meters above ground level, then the tripod legs must be bolted down to prevent the unit from falling to the ground. An accidental fall of more than three meters may compromise the containment of the radioactive source and the unit will need to be returned to the factory for testing. In addition, dropping the E-BAM from any height will cause a potential safety hazard for those below, and may damage the unit beyond repair.

The E-BAM tripod should be secured to the mounting surface in windy conditions to prevent the unit from falling over, even at ground level. This is especially important in winds over 30 mph. If bolt-down is not possible, then the tripod legs may be weighted down with sand bags to secure the unit. Wind or fall damage is not covered under warranty.

The E-BAM should be secured from theft or vandalism to the extent possible. A limited-access rooftop or a fenced lot are often good places to deploy the unit. Solar panels and batteries are also highly susceptible to theft and should be secured.

## **4.3 Confined Sampling Locations**

Because of the portable nature of the unit, the E-BAM is sometimes deployed in confined or non-ambient locations to monitor highly localized particulate sources, such as tunnels, mines, quarries, shopping malls, train stations, etc. Each of these applications are unique and present various challenges. We recommend that you contact a Met One Service representative to determine the suitability of the unit if you plan a custom deployment like this.

#### **4.4 Smoke and Ash Monitoring**

A primary design use for the standard E-BAM is for tracking smoke and ash plumes from wildfires, prescribed burns, agricultural burns, and even volcanic activity. In these cases, the unit is often sited at the outskirts of a populated area in the expected path of the smoke plume. The unit is usually equipped with the optional EX-034 wind speed and direction sensor for these applications, in order to correlate changing wind patterns with particulate events. The wind sensor is plug-and-play, and only requires an extended cross-arm for the tripod mount. The EX-034 will need to be oriented to the north for accurate wind direction measurements.

In smoke tracking applications, the filter tape may be consumed at a much faster rate than normal. This is because the E-BAM may automatically advance the filter to a new spot if the particulate loading becomes excessive, **regardless of the user-defined tape advance setting**. This is based on the measured pressure drop across the filter tape. This feature protects the pump, preserves accurate flow control, and prevents damage to the filter tape.

#### **4.5 Remote Monitoring With Solar or Battery Power**

The standard version of the E-BAM is designed to be deployable in remote areas where AC power is not available. These applications require deep-cycle batteries, and sometimes a solar panel array as well. The E-BAM is rated for a worst-case continuous power draw of 50 Watts (approximately 4.1 amps at 12 volts DC).

##### **Battery Operation:**

The simplest method for remote deployment is to use batteries. The most common type for this application are 12 volt, 110 amp-hour, gel-cell or AGM, deep cycle batteries. The E-BAM is supplied with a battery cable which plugs into the power connector on the bottom of the unit. The other end connects to the battery terminals. The batteries are typically enclosed in a plastic box on the ground near the E-BAM.

Assuming a continuous E-BAM current draw of 4.1 amps, a single fully-charged 110Ah battery would have the theoretical capacity to run the unit for 26.8 hours. However, the general rule is that a lead-acid battery should not be discharged by more than 2/3 of its capacity, especially in temperatures below 40 degrees F, so:

$$((110\text{Ah} / 4.1\text{A}) * .67) = \mathbf{18.0} \text{ hours of run time per battery.}$$

Additional run time is achieved by connecting more batteries **in parallel** to the first battery. Additional batteries **must** be of the same type! A set of three fully charged 110Ah batteries in parallel should run an E-BAM for at least 54 hours under worst-case conditions. When the battery voltage discharges below 10.0 volts, the unit will shut itself down until fresh batteries are supplied and the restart voltage threshold is exceeded. See Section 7.10.

##### **Solar Operation:**

Some remote applications require operating the E-BAM with a solar array. Care must be taken to ensure that the solar array is designed correctly, and is specified to meet the power requirements of the unit. Many people greatly underestimate the amount of solar wattage required to run a particular load continuously year-round. If the solar array is not large enough, the batteries will eventually become depleted and the E-BAM will shut down. The size of the solar array will vary depending on the Peak Sun-Hour (PSH) rating of the sample location. PSH ratings are usually based on worst

case winter conditions at a particular location. Summer sun ratings at the same location will be considerably higher. Sun rating maps can be found on the National Renewable Energy Laboratory website at [www.nrel.gov](http://www.nrel.gov). The table below shows some estimated solar array wattages required to run a 50 Watt DC E-BAM continuously in various sun ratings:

Local PSH Sun Rating kWh/m <sup>2</sup> /day	Minimum Solar Array Wattage	Battery Array for 5 Days Backup
2.0	1010	7 x 110Ah
2.5	810	7 x 110Ah
3.0	675	7 x 110Ah
3.5	580	7 x 110Ah
4.0	500	7 x 110Ah
4.5	450	7 x 110Ah
5.0	400	7 x 110Ah
5.5	370	7 x 110Ah
6.0	340	7 x 110Ah
6.5	310	7 x 110Ah
7.0	290	7 x 110Ah

A bank of parallel batteries is required to run the E-BAM when using a solar array, to ensure function during the night and cloudy weather. The solar panels must be wired to charge the batteries through an appropriate charge controller. The E-BAM runs off of the battery pack only. **Never connect a solar panel directly to the E-BAM power input!** The E-BAM will be immediately damaged because solar panels output a high DC voltage during sunlight hours. The E-BAM will only run on 12 to 16 VDC. Ensure that the charge controller output does not exceed 16 volts when connected to the battery pack, or damage to the E-BAM can result.

A solar array for the E-BAM tends to end up being fairly large, heavy, and expensive. It is usually easiest and cheapest to contact your local solar shop for help in building the array. You may also contact a service representative at Met One for assistance. Met One Instruments can also supply complete E-BAM solar systems on a custom order basis.

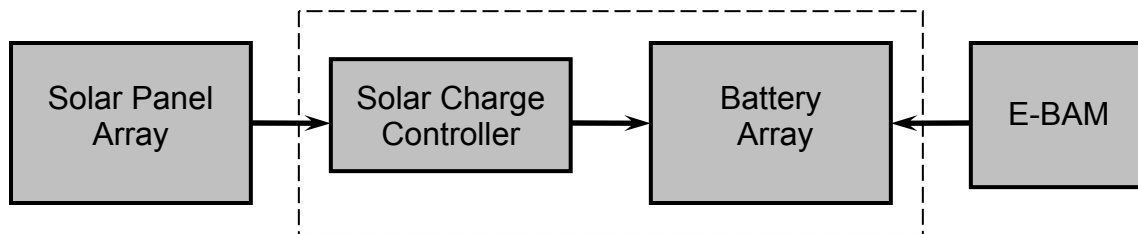

**Simplified E-BAM Solar System Block Diagram**

## 5 FIELD CALIBRATIONS AND FLOW CHECKS

This section describes the audit and calibration process for the E-BAM flow system, ambient temperature sensor, barometric pressure sensors, filter sensors, analog output, and span membrane. **The most important maintenance parameters are the leak checks, nozzle/vane cleaning, and flow checks!** The audit screens for the parameters described here are all found in the FIELD CALIBRATION menu under the main E-BAM menu as shown below:



The main E-BAM menu

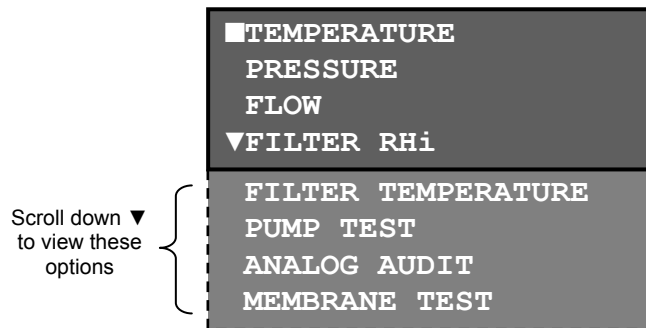

The FIELD CALIBRATION menu

### 5.1 Leak Checks and Nozzle/Vane Cleaning

The E-BAM flow system *must be checked for leaks before any flow calibrations are performed.* Scroll to the PUMP TEST line and press the MENU/SELECT key to enter the leak test and pump test menu. The pump will turn on automatically when this screen is entered:

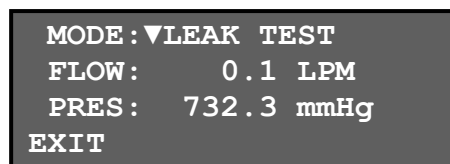

The MODE parameter selects either the LEAK TEST or the PUMP TEST mode. The LEAK TEST mode is used to check for flow leaks and to measure the leakage at the filter tape nozzle interface. The PUMP TEST mode is used to test the capacity of the pump to determine when it needs to be replaced.

The FLOW parameter is the instantaneous output from the unit's internal flow sensor. This is the parameter that you are auditing. The PRES parameter is not used during the leak test.

### Perform the leak check as follows:

1. Verify that a fresh spot of tape is located beneath the nozzle. If the tape is damaged it may be difficult to pass the leak check.
2. Remove the PM<sub>10</sub> head from the inlet tube. Install a BX-305 leak test valve (or equivalent valve for leak checking FRM samplers) onto the inlet tube. Turn the valve to the OFF position to prevent any air from entering the inlet tube. If a PM<sub>2.5</sub> inlet cyclone is used, it is usually best to install the leak valve above the cyclone in order to test it for leaks as well.
3. Enter the PUMP TEST screen as described above, and set the MODE to LEAK TEST. The pump should turn on automatically and ramp up to full speed.
4. The flow rate should drop below **1.0 lpm**. If the leak value is greater than 1 lpm, then the nozzle and vane need cleaning, or there may be another leak somewhere in the system.
5. Resolve the leak and perform the check again. A properly functioning E-BAM with a clean nozzle and vane will usually have a leak value of about **0.6 lpm or less** using this method, depending on the type of pump used.
6. When finished, exit the TEST PUMP menu, remove the leak test valve, and re-install the inlet heads.



### Important Notes About Leak Checks:

Leak checks should be performed at least monthly and whenever the filter tape is changed. Almost all air leaks in the E-BAM system occur where the nozzle contacts the filter tape. **The E-BAM has no way of automatically detecting a leak at this interface!** This is because the airflow sensor is located downstream of the filter tape. There will normally be a small amount of leakage at the tape, but an excessive leak lets an unknown amount of air enter the system through the leak instead of the inlet. This will cause the air volume calculation and the concentration measurement to be incorrect. **Allowing a leak to persist may cause data to be invalidated back to the last known good leak check.**

The 1.0 lpm leak check allowance is due to the test conditions. With the inlet shut off, the vacuum in the flow system is several times greater than during normal sampling, which exaggerates any leaks. If the leak reading during this test is less than 1.0 lpm, there should not be a significant leak during normal operation.

Some agencies choose to adopt tighter tolerances for the leak test, such as requiring a leak value of 0.5 lpm or less after the nozzle and vane are cleaned. Most agencies perform as-found leak checks (before cleaning the nozzle and vane) for data validation purposes. The typical recommended threshold for invalidating data is an as-found leak value (before cleaning nozzle and vane) of 1.5 lpm or higher. Again, some agencies adopt tighter standards, such as invalidating data if the as-found leak value is greater than 1.0 lpm.

### Nozzle and Vane Cleaning:

The nozzle and vane (located under the tape) must be cleaned regularly to prevent leaks and measurement errors. The cleaning must be done at least each time the filter tape is changed, though monthly cleaning is highly recommended. Some sites will require more frequent cleaning as determined by the site administrator. The worst environment for nozzle contamination seems to be hot, humid environments. This is because damp filter tape fibers more easily stick to the nozzle and



vane. The fibers can quickly build up, creating air leaks or punching small holes in the filter tape which will cause measurement errors. Use the following steps to clean the parts:

1. It is advisable to perform an as-found leak check before cleaning the nozzle, in order to validate past data as being leak-free.
2. If the nozzle is down, raise it by entering the LOAD TAPE screen in the main E-BAM menu. The nozzle will automatically raise.
3. Remove the filter tape (if installed) from the nozzle area so that you have access to the vane.
4. Thoroughly clean the nozzle sealing surface and the vane crosshairs with a cotton-tipped applicator and isopropyl alcohol. Any hardened deposits may have to be carefully scraped off with the wooden end of the applicator.
5. Inspect the nozzle lip and vane for any burrs which may cause leaks or tape damage.
6. After the cleaning process, it is recommended to use canned dusting air to blow down through the vane crosshairs. This removes any filter debris from the face of the beta detector, which is located directly under the vane. Be careful not to damage the beta detector window!
7. Reinstall the filter tape and perform a final leak check.

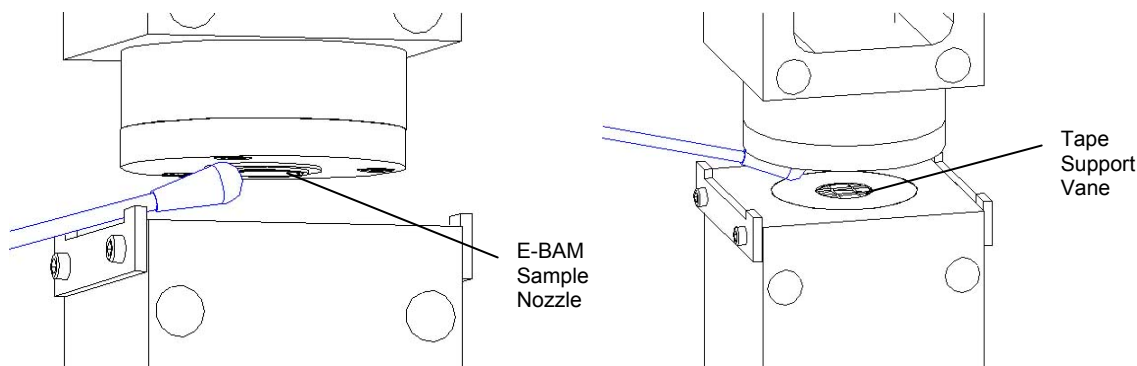

**Cleaning the E-BAM nozzle and Vane with a cotton-tipped applicator**

The figure below shows the difference between good and bad filter tape spots. The tape on the right is from an E-BAM with a clean nozzle and vane. The particulate spots have crisp edges, are perfectly round, and are evenly distributed. The tape on the left is from a unit with a dirty vane. A spot of debris has built up, and is punching a pin-hole at the edge of each spot. The spots also show a “halo” effect from an air leak because the debris has built up to the extent that the nozzle no longer seals correctly. These faults are easily prevented by keeping the nozzle and vane clean.

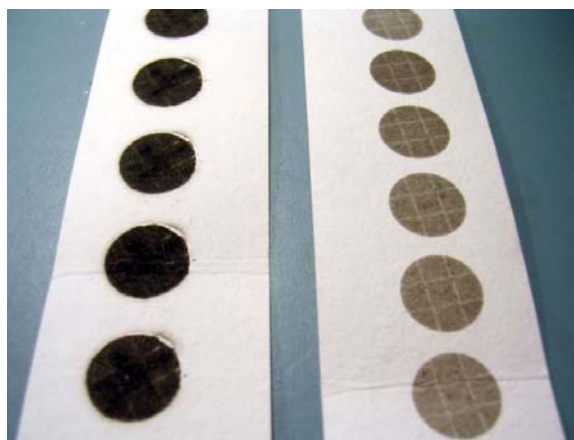

**E-BAM Filter Tape Examples**

## 5.2 Ambient Temperature Sensor Audit

The ambient temperature must be audited or calibrated before any flow calibrations are performed. Scroll to the TEMPERATURE line and press the MENU/SELECT key to enter the ambient temperature sensor calibration menu:

```
POINT:▼HIGH
E-BAM: 23.6 C
REF: 23.9 C
CALIBRATE      DEFAULT
```

```
POINT:▼LOW
E-BAM: -10.2 C
REF: -10.8 C
CALIBRATE      DEFAULT
```

The POINT parameter selects either the HIGH or LOW calibration point. The HIGH point is the normal ambient calibration point which is used for all field calibrations. The LOW point is only used for laboratory ice-bath calibrations of the ambient temperature sensor. Select HIGH to perform an ambient temperature sensor calibration.

The E-BAM parameter is the instantaneous output from the unit's ambient temperature sensor. This is the parameter that you are auditing.

The REF parameter is the field where you enter the correct temperature as shown on your traceable reference standard temperature audit device. After you have entered the correct temperature using the arrow keys, press the CALIBRATE key to correct the E-BAM sensor reading. The E-BAM and REF parameters should now match. Press the ESC key when finished.

If difficulty is encountered during the process, the DEFAULT key can be pressed to erase all field calibration factors from the temperature sensor and to start over with factory default calibration factors. Then try the calibration again.

## 5.3 Ambient Barometric Pressure Sensor Audit

The ambient barometric pressure sensor must be audited or calibrated before any flow calibrations are performed. Scroll to the PRESSURE line and press the MENU/SELECT key to enter the ambient pressure sensor calibration menu:

```
PRESSURE
E-BAM: 732.8 mmHg
REF: 737.9 mmHg
CALIBRATE      DEFAULT
```

The E-BAM parameter is the instantaneous output from the unit's ambient barometric pressure sensor. This is the parameter that you are auditing.

The REF parameter is the field where you enter the correct pressure as shown on your traceable reference standard barometric pressure audit device. After you have entered the correct pressure using the arrow keys, press the CALIBRATE key to correct the E-BAM sensor reading. The E-BAM and REF parameters should now match. Press the ESC key when finished.

If difficulty is encountered during the process, the DEFAULT key can be pressed to erase all field calibration factors from the pressure sensor and to start over with factory default calibration factors. Then try the calibration again.

### 5.4 Flow Audits and Calibrations

The flow calibration is performed after the temperature and pressure sensors are audited, because the E-BAM uses these parameters to calculate flow. In addition, *the nozzle and vane must be clean, and a leak check must be performed before the flow calibration.* You will need to remove the PM<sub>10</sub> inlet head and install your traceable reference standard flow audit device (BGI deltaCal<sup>®</sup> or equivalent) onto the top of the E-BAM inlet tube to measure the flow.

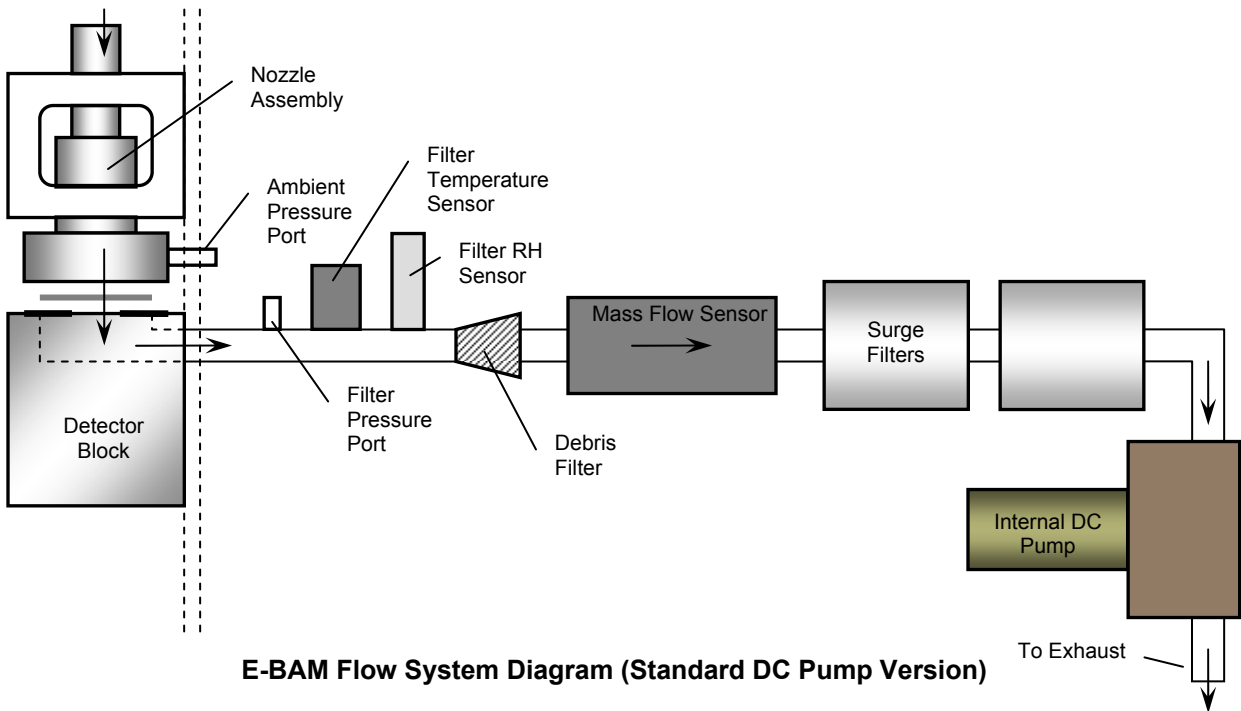

Scroll to the FLOW line and press the MENU/SELECT key to enter the flow sensor calibration menu as shown:

SETPOINT: ▼17.5 LPM E-BAM: 17.5 LPM REF: 17.4 LPM CALIBRATE      DEFAULT	SETPOINT: ▼14.0 LPM E-BAM: 14.0 LPM REF: 14.1 LPM CALIBRATE      DEFAULT	SETPOINT: ▼16.7 LPM E-BAM: 16.7 LPM REF: 16.6 LPM EXIT
---	---	---

The SETPOINT parameter selects which flow point is to be calibrated. The E-BAM uses a two-point flow calibration at 17.5 and 14.0 lpm. The 16.7 lpm point can only be audited, not calibrated. Notice that there is no CALIBRATE option when the SETPOINT is set to 16.7. Use the arrow keys to select the 17.5 lpm setpoint first. The E-BAM will automatically turn the pump on and regulate the flow until the internal flow sensor output matches the 17.5 lpm setpoint. It may take a moment for the flow to regulate to the setpoint. Note: The high flow point also verifies the pump’s ability to maintain adequate head room above the 16.7 lpm sample flow rate, so make sure that the unit can regulate to this point.

The E-BAM parameter is the instantaneous output from the unit's internal flow sensor. This is the parameter that you are auditing.

The REF parameter is the field where you enter the correct flow as shown on your traceable reference standard flow audit device. After you have entered the correct flow using the arrow keys, press the CALIBRATE key to correct the E-BAM sensor reading. The E-BAM should then re-regulate the flow to the setpoint, and the E-BAM and REF parameters should match.

Set the SETPOINT to 14.0 lpm and repeat the calibration process. After the 17.5 and 14.0 lpm points are calibrated, select the 16.7 lpm setpoint and verify that the E-BAM flow and the flow from your traceable standard match within 0.1 lpm. Press the ESC key to exit the flow calibration menu when finished.

If difficulty is encountered during the process, the DEFAULT key can be pressed to erase all field calibration factors from the flow sensor and to start over with factory default calibration factors. Then try the calibration again.

To audit the flow system without performing any calibrations, simply select the 16.7 lpm setpoint without calibrating the other setpoints first. Allow the E-BAM flow to regulate to the setpoint, then compare the E-BAM flow reading to your traceable standard and record the results. If the audit device flow and the E-BAM flow differ by 4% (about 0.67 lpm) or more, then a full flow calibration must be performed. Most agencies adopt tighter standards. Met One recommends that the flow be maintained within  $\pm 0.2$  lpm, which is well within the units capabilities.

**Flow Calibrations on E-BAMs Operated in STANDARD Flow Type:** If your E-BAM is set to report in EPA Standard flow conditions instead of actual (volumetric) flow conditions, then the flow reading in the FLOW calibration screens shown above will indicate SLPM instead of LPM. **It is critical that the flow type of your traceable flow audit device matches the flow type of the E-BAM.** Flow calibration on E-BAM units operated in STANDARD flow mode can be done a couple of different ways:

- The easiest method is to simply use a traceable flow audit device which reports STANDARD flow values, such as the BGI deltaCal which reports both STANDARD ( $Q_s$ ) and ACTUAL ( $Q_a$ ) flow.
- The second option is to change the FLOW TYPE from STANDARD to ACTUAL in the E-BAM SETUP menu, then perform a regular flow calibration as described above. If this method is used, be sure to set the unit back to STANDARD flow when finished.
- The third option is to convert the ACTUAL flow output from your traceable reference flow meter to STANDARD conditions ( $Q_s$ ) using a formula:

$$Q_s = Q_a * (P_a / T_a) * (298 / 760)$$

$T_a$  = Ambient Temperature Kelvin (Kelvin = Celsius + 273)

$P_a$  = Ambient Barometric Pressure (mmHg)

$Q_a$  = Actual Volumetric Flow from Reference Meter

## 5.5 Filter RH Sensor Audit

The filter relative humidity sensor is used to measure the humidity of the sample air and to control the inlet heater to prevent moisture from being sampled as particulate mass. Scroll to the FILTER RHi (RH internal) line and press the MENU/SELECT key to enter the filter RH sensor calibration menu:

```
FILTER RHi
E-BAM: 32 %
REF: 35 %
CALIBRATE      DEFAULT
```

The E-BAM parameter is the instantaneous output from the unit's filter RH sensor. This is the parameter that you are auditing.

The REF parameter is the field where you enter the correct RH as shown on your traceable reference standard relative humidity audit device. After you have entered the correct RH using the arrow keys, press the CALIBRATE key to correct the E-BAM sensor reading. The E-BAM and REF parameters should now match. Press the ESC key when finished.

If difficulty is encountered during the process, the DEFAULT key can be pressed to erase all field calibration factors from the RH sensor and to start over with factory default calibration factors. Then try the calibration again.

**Important Note:** It is often difficult to calibrate the sensor if the E-BAM is warm, as the heating of the unit will reduce the sample RH (as it should) making it difficult to compare the E-BAM filter RH reading to an ambient RH traceable standard reading. If the sensor is to be calibrated, it is best to do it when the E-BAM is cold (equilibrated to ambient) and the nozzle is lifted up. It is recommended to leave the sensor at the factory default calibration. The E-BAM filter RH sensor is only a  $\pm 4\%$  device when functioning properly, and will typically read a completely unreasonable value if it fails, such as 135% or -25%.

## 5.6 Filter Temperature Sensor Audit

The filter temperature sensor is used to measure the temperature of the sample air and to monitor the function of the inlet heater. Scroll to the FILTER TEMPERATURE line and press the MENU/SELECT key to enter the filter temperature sensor calibration menu:

```
FILTER TEMPERATURE
E-BAM: 23.8 C
REF: 24.6 C
CALIBRATE      DEFAULT
```

The E-BAM parameter is the instantaneous output from the unit's filter temperature sensor. This is the parameter that you are auditing.

The REF parameter is the field where you enter the correct temperature as shown on your traceable reference standard temperature audit device. After you have entered the correct temperature using

the arrow keys, press the CALIBRATE key to correct the E-BAM sensor reading. The E-BAM and REF parameters should now match. Press the ESC key when finished.

If difficulty is encountered during the process, the DEFAULT key can be pressed to erase all field calibration factors from the temperature sensor and to start over with factory default calibration factors. Then try the calibration again.

**Important Note:** It is often difficult to calibrate the sensor if the E-BAM is warm, as the heating of the unit will increase the sample temperature (as it should) making it difficult to compare the E-BAM filter temperature reading to an ambient temperature traceable standard reading. If the sensor is to be calibrated, it is best to do it when the E-BAM is cold (equilibrated to ambient) and the nozzle is lifted up. It is recommended to leave the sensor at the factory default calibration. The E-BAM filter temperature sensor very rarely fails.

## 5.7 Pump Tests

The E-BAM pump should be periodically tested to ensure it has sufficient vacuum capacity for normal operation. Scroll to the PUMP TEST line and press the MENU/SELECT key to enter the leak test and pump test menu. The pump will turn on automatically when this screen is entered:

```
MODE:▼PUMP TEST
FLOW: 14.3 LPM
PRES: 398.3 mmHg
EXIT
```

The MODE parameter selects either the LEAK TEST or the PUMP TEST mode. The PUMP TEST mode is used to test the capacity of the pump to determine when it needs to be replaced.

The FLOW parameter is the instantaneous output from the unit's internal flow sensor.

The PRES parameter is the filter pressure reading which indicates the vacuum beneath the filter tape. This is used to measure the vacuum capacity of the pump during the pump test.

Perform the pump test as follows:

1. Remove the PM<sub>10</sub> head and install the BX-305 leak test valve onto the inlet tube. Turn the valve to the OFF position to prevent any air from entering the inlet tube.
2. Enter the PUMP TEST screen as described above, and set the MODE to LEAK TEST. The pump should turn on automatically and ramp up to full speed.
3. **Very slowly** open the leak check valve on the inlet just a small amount, so that the FLOW reading on the E-BAM display increases to between 14 and 15 lpm, with the pump still at full speed. Allow the flow reading to stabilize.
4. Compare the PRES (vacuum) value from the E-BAM display to the chart below for the particular flow rate. The PRES value should be less than or equal to the values in the chart. If the PRES value on the E-BAM display is higher than the "poor" value in the chart at that particular flow rate, then the E-BAM pump may need to be replaced.

Flow Rate	Vacuum Measurement Value		
	Good	Marginal	Poor
14.0	390.5	406.1	429.5
14.1	391.6	407.3	430.8
14.2	393.8	409.6	433.2
14.3	395.0	410.8	434.5
14.4	396.5	412.3	436.1
14.5	398.5	414.5	438.4
14.6	399.5	415.5	439.5
14.7	401.1	417.2	441.3
14.8	403.2	419.3	443.5
14.9	404.5	420.7	445.0
15.0	406.0	422.2	446.6

**Notes on Pump Testing:** The test above is simply a way to quantify the pump capacity. The true indicator of pump function is its ability to maintain 16.7 lpm during normal operation, despite filter loading and altitude. The simplest and most effective way to verify the pump capacity is to just verify that the E-BAM flow can regulate at the 17.5 lpm flow rate during the normal flow calibrations. The internal DC diaphragm pump in the standard version of the E-BAM has an estimated lifetime of six to nine months in continuous operation, or at least 4000 hours in intermittent operation. Actual lifetime varies depending on concentration levels and ambient temperature. The pump is not rebuildable, and must be replaced. Contact the Met One Service Department to obtain a replacement.

### 5.8 Analog Output Audits

If the E-BAM is used with an external analog datalogger, then the analog voltage output of the E-BAM must be periodically checked to ensure data integrity. Scroll to the ANALOG AUDIT line and press the MENU/SELECT key to enter the analog output test menu:

MODE : ▼AUDIT  SETPT : 0.500 V EXIT	MODE : ▼HIGH OUTPUT : 0.990 V ADJUST : 0.000 SAVE                      DEFAULT	MODE : ▼LOW OUTPUT : 0.010 V ADJUST : 0.000 SAVE                      DEFAULT
--	---	--

The MODE parameter selects either the AUDIT mode, or the HIGH or LOW adjustment modes as shown above. In the AUDIT mode, the user can use the arrow keys to change the SETPT voltage to any value between 0.000 and 1.000 volts DC. The actual voltage measured on the E-BAM analog output wires must match this setting within  $\pm 0.001$  volts. If not, the analog output on the E-BAM will need to be adjusted.

In the HIGH mode, the analog output is forced to 0.990 volts. Measure the actual voltage output of the E-BAM, and if it does not match, the ADJUST field can be set (using the arrow keys) to adjust the voltage up or down by as much as 0.100 volts. In the LOW mode, the analog output is forced to 0.010 volts. Measure the actual voltage output again and make any adjustments. The LOW mode can only be adjusted from -0.016 to 0.100 volts. After the HIGH and LOW modes are adjusted, go back to the AUDIT mode and make sure that all voltage points from 0.000 to 1.000 volts now match your voltmeter within  $\pm 0.001$  volts.

**Notes About the Analog Output Tests:** Only a high quality voltmeter should be used for this test. Cheap voltmeters usually do not give accurate measurements at millivolt levels. The E-BAM analog output should also be checked with the external datalogger connected, in order to make sure that the logger or cables are not affecting the voltage.

The E-BAM analog output is split out of the serial communications cable. If your serial cable does not have an analog output breakout, contact the Met One Service department.

### 5.9 Span Membrane Tests

The membrane test is used to audit the E-BAM beta particle measurement system by simulating a particulate load with a polyester foil. The test consists of four 4-minute beta count steps for a total of about 16 minutes.

Step	Count Type	Description
1	BLANK ZERO COUNT	4-min count through filter tape only.
2	CAL ZERO COUNT	4-min count through tape and zero (empty) membrane.
3	BLANK SPAN COUNT	4-min count through filter tape only.
4	CAL SPAN COUNT	4-min count through tape and span membrane foil.

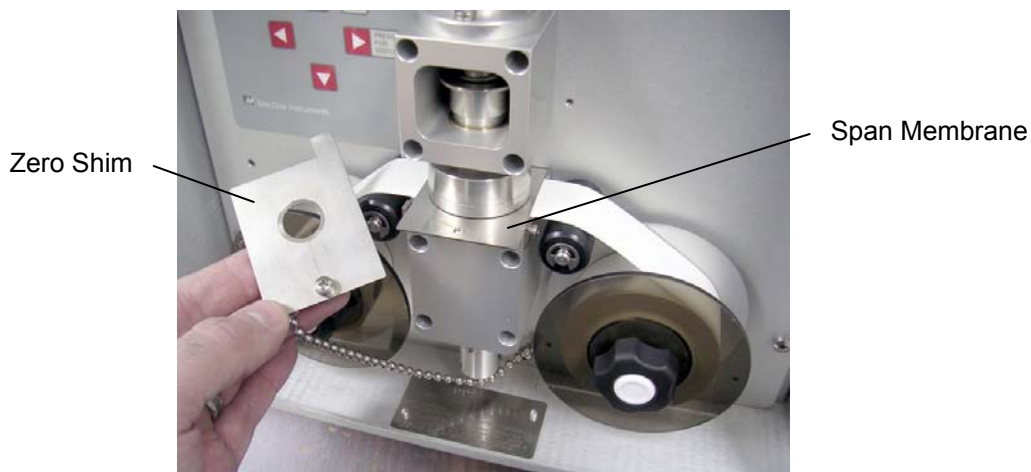

Span Membrane and Zero Shim

Scroll to the MEMBRANE TEST line and press the MENU/SELECT key to enter the membrane test menu. The E-BAM will ask to start the test as shown below. Press the START key to begin the test. The unit will advance the filter tape and begin a 4-minute blank zero count. Then the unit will raise the nozzle and prompt you to enter the insert the zero membrane. This is the same shim that is used to protect the nozzle during shipment and is connected to the unit with a chain:

<p>MEMBRANE TEST START ZERO TEST.</p> <p>START</p>	<p>BLANK ZERO COUNT</p> <p>■■■■ 172</p> <p>CANCEL</p>	<p>INSERT ZERO MEMBRANE</p> <p>CANCEL</p>
--	---	---

Insert the zero membrane (on top of the filter tape) so that the tab protrudes through the transport plate and triggers the photo sensor. The nozzle will lower and the unit will begin a 4-minute count



with the zero membrane in place. After the zero count, the unit will prompt you to remove the zero membrane. The unit will then start a 4-minute blank span count without any membrane in place:

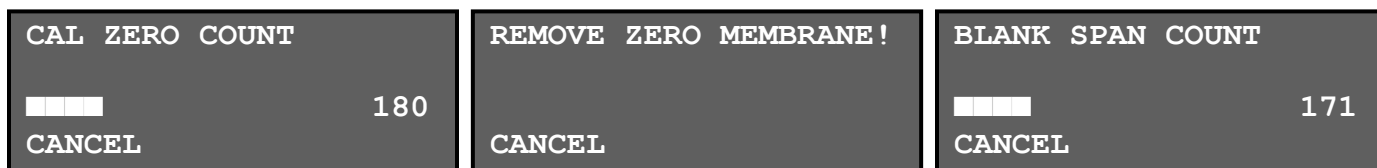

The unit will then prompt you to insert the span membrane. This is located in a pouch inside the E-BAM door. Handle the span membrane very carefully to avoid damaging the fragile film. Insert the span membrane into the E-BAM above the filter tape. The unit will perform the final 4-minute span count and display the results:

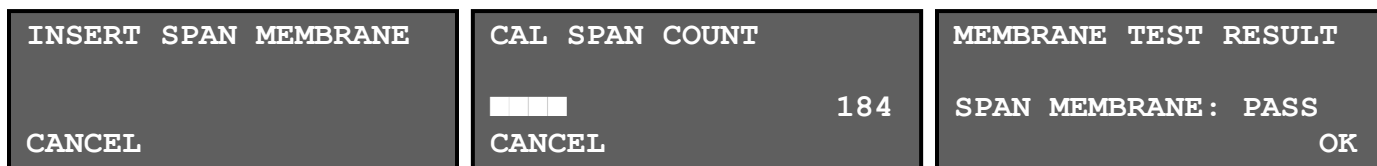

This is a pass/fail test in which the E-BAM will compare the measured mass of the span membrane to the expected mass (ABS) for that exact foil which has been programmed into the E-BAM memory. See Section 7.12. If the measured and expected values are within 5%, the test will pass. If the values are outside of 5%, a failure will be generated. If the test fails, the most common causes are a failing or dirty beta detector, or a dirty or damaged span membrane.

The measured span value from the test can be viewed. Press the ▼ (down arrow) button on the E-BAM while it is displaying the pass or failure message at the end of the test. The display should show the ZERO and SPAN values the unit just measured. Compare the SPAN value from the display to the expected mass of the membrane (ABS value).

The ZERO and SPAN values from a failed membrane test may also be downloaded through the serial port of the E-BAM with a computer. Download the Error Log, and find the appropriate Membrane Test Failure record and look for the “Z” and “S” values.

## 6 THE E-BAM MEASUREMENT CYCLE

This section describes the measurement and timing cycles of the E-BAM instrument. A clear understanding of the measurement is helpful for the effective operation of the unit and for data analysis. For advanced information on the underlying theory and mathematics of the measurement see Theory of Operation, Section 11.

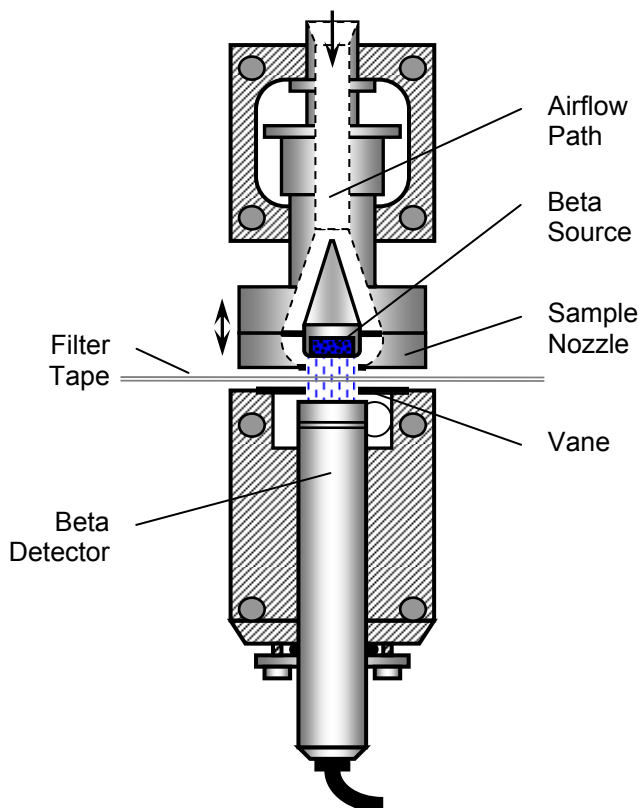

E-BAM Beta Measurement System (not to scale)

### 6.1 The Hourly Measurement Cycle

The E-BAM will always make an hourly concentration measurement *regardless of how the real-time average is set*. This hourly measurement is stored to the data array each hour, and is a fixed data parameter which cannot be modified or removed from the array. *The hourly value is the most accurate concentration measurement made by the E-BAM*. Daily averages are computed by taking the 24-hour mean of these hourly data points.

The hourly concentration is based on two four minute long beta counts, one at the beginning and one at the end of each sample hour. At the beginning of the sample hour (minutes 2 to 5), the E-BAM counts the beta particles through the filter tape for four minutes to establish a zero reading. Particulate then accumulates on the tape spot throughout the hour. At the end of the sample hour (minutes 57 to 60) the unit makes another four minute long beta count through the dirty filter tape to establish a span reading. The two beta counts are used to calculate the particulate mass on the tape, and the air flow data over the sample hour is used to determine the particulate concentration in milligrams per cubic meter of air. As soon as the new hour starts, the E-BAM stores the previous hourly concentration to the data array, and starts a new hourly measurement.

**Note: The hourly E-BAM concentration measurement is not an hourly average of the real-time measurements!** These are two completely separate measurements. For example, if the E-BAM is set for a real-time average of five minutes, then the unit will store 12 real-time values over the course of an hour. The average of these twelve real-time values may not exactly match the hourly value for that same hour, though they should be fairly close.

When the filter tape advances in the middle of a sample hour due to heavy particulate loading on the sample spot, the E-BAM is still able to make the hourly concentration measurement for that hour. This is known as a “split cycle” measurement, and is based on a time-weighted average of the concentration before and after the tape advance. This is because a tape advance could occur at any time during the sample hour. The hourly concentration data point will still appear in the data array, along with a pressure drop alarm flag. The hourly data points that occur during these tape advance hours are somewhat less reliable than normal hourly measurements because the original four minute beta count cannot be used as a baseline for the final four minute count at the end of the hour. For this reason, some agencies omit these points from their 24 hour averages. If the E-BAM records pressure-drop tape advances every day, it is advisable to simply shorten the automatic tape advance setting.

## **6.2 The Real-Time Average Measurement Cycle**

The beta source and beta detector are located inside the air path of the E-BAM. This allows the E-BAM to simultaneously measure the beta attenuation of the particulate *as it is being deposited on the filter tape*, resulting in a quasi real-time output. The vacuum pump is always running except when the tape is moved, and the E-BAM is constantly measuring the beta particle signal throughout the entire sample period. The unit generates raw real-time concentration measurements which are updated every 60 seconds. The Real Time Average stored by the E-BAM is a user-selected average of these 60-second measurements over a 1, 5, 10, 15, 30, or 60 minute period. See Section 7.2 for details on how to decide which real-time average to use, and how to set the average. The real-time average is intended for particulate trending throughout the sample hour, especially for smoke plume tracking.

Several factors conspire to make real-time beta measurement difficult. First, very little particulate is deposited on the filter tape in such a short time, resulting in a poor signal-to-noise ratio except in high concentrations. Second, very little air is sampled in such a short time, increasing the detection limit of the real-time output. Third, the sample air is flowing around the beta source and beta detector, so correction factors for air density and temperature are used by the E-BAM to compensate for the effect on the beta signal. *All of these factors become less significant the longer the real-time average period is set to.* For these reasons, any single real-time average measurement from the E-BAM (especially a 1 or 5 minute average) may not be an accurate representation of the true particulate level at that exact moment, but it will be useful for trending and detecting sudden spikes in concentration. However, the main advantage of the E-BAM style real-time output over other methods (such as laser based nephelometers) is that the beta method does not require any K factors or slope corrections for changes in variables such as particle size, color, or chemical composition.

E-BAM real-time measurements are based on a constant series of one minute long beta particle count totals. These one minute counts are averaged into a four minute rolling average, so each minute a new one minute count value is added to the average, and the oldest value is dropped out. To make a concentration measurement, the E-BAM needs two of these rolling averages, an initial or “zero” count average ( $I_0$ ) and a final count average ( $I_X$ ) separated by some time period for particulate to accumulate. Each minute, both of the four minute rolling averages are advanced by one minute, and a new concentration value is calculated and stored. These are the raw 60-second real-time values which are averaged together over 5, 10, 15, or 30 minutes to form the user-selected real-time average concentration values.

- At the beginning of a new sample period, such as when the unit is started up, or whenever the filter tape is advanced to a fresh spot, The unit must start all counts and rolling averages over.
- For the first four minutes after any tape advance, there will be no 60-second real-time concentration values generated, because the four minute rolling average for the zero beta count has not finished loading up.
- At the end of minute five, the E-BAM will have the two required four minute rolling averages, but they will be overlapping. The  $I_0$  count will be a rolling average of the count totals from minutes 1 to 4, and the  $I_X$  count will be a rolling average of the count totals from minutes 2 to 5. A 60-second raw real-time concentration value will be calculated from these.
- At the end of minutes 6 and 7 additional 60-second raw real-time concentrations will be calculated, again based on overlapping four minute rolling averages of the beta counts. Each minute the final  $I_X$  rolling average gets farther away from the  $I_0$  rolling average, reducing the noise of the resulting concentration values.
- At the end of minutes 8, 9, 10, and 11, the concentration values are still generated based on the  $I_0$  rolling average from minutes 1 to 4, but the  $I_X$  rolling average continues to get farther away each minute and is no longer overlapping the  $I_0$  rolling average.
- At the end of minute 12, the first “normal” 60-second raw real-time concentration is calculated when there are a *full eight minutes between the end of the  $I_0$  rolling average (minute 4) and the end of the  $I_X$  rolling average (minute 12)*.
- Each minute after minute 12, both the  $I_0$  and the  $I_X$  rolling averages advance by one minute, so that the end of each of the two average are always separated by exactly eight minutes. The 60-second raw real-time concentration values generated during and after this time are all normal and useful values.
- At the first user-selected real-time average period (such as 10 or 15 minutes), The unit averages all of the 60-second raw real-time concentration values over that selected time period into the REALTIME AVERAGE, and stores it to the data array.
- The process continues until the next time the filter tape is advanced to a fresh spot.

The 60-second raw real-time concentration values generated during the first 11 minutes after a filter change tend to be noisy due to the shortened time between the count averages. For this reason, the first real-time average of these raw values is often disregarded after an E-BAM tape advance.

The following chart shows the four minute rolling average count sequences that the E-BAM uses to generate the real-time output as described above. In this example the tape has advanced at minute zero, and the real-time average period is set to fifteen minutes.

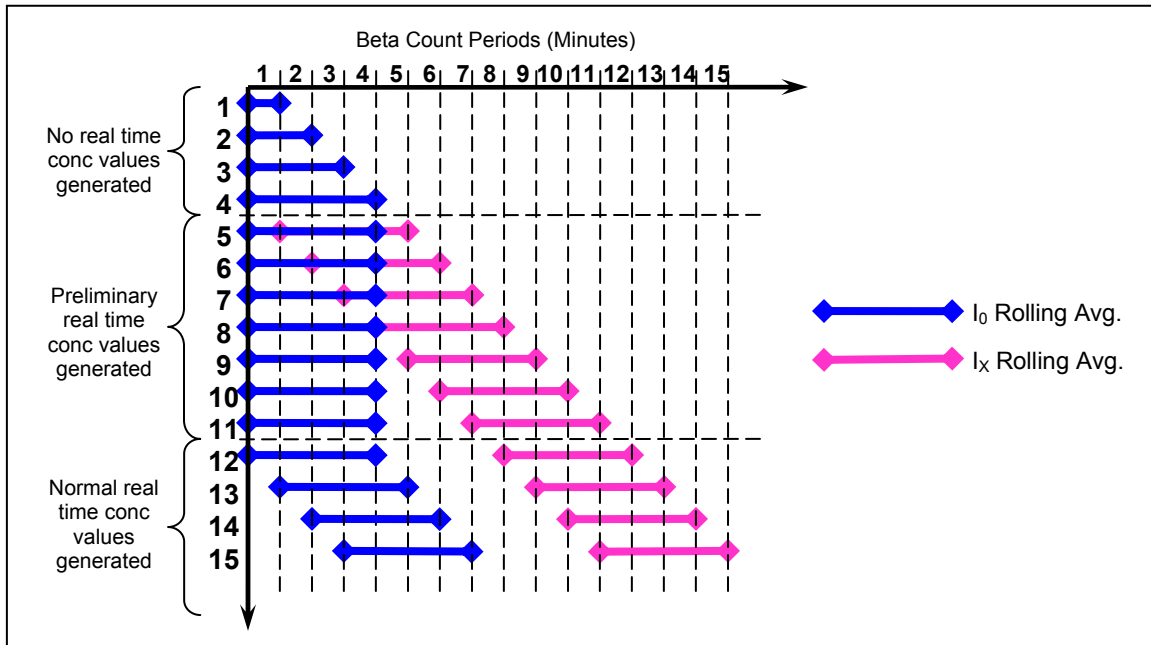

The table below shows the relationship between the  $I_0$  and  $I_x$  four minute rolling average counts, the 60-second raw real-time concentration values, and the resulting real-time averages. Notice how the real-time values load up after the tape advance as described above. In this example, after fifteen minutes a real-time average is generated and is held constant until minute 30 when it is updated again. The first real time average will not include the first four minutes after a filter change.

Minute	Real-Time	Real-Time	Real-Time	15-Min
	$I_0$	$I_x$	60-sec Conc	RT Average
	Minutes	Minutes	mg/m3	mg/m3
1	---	---	None	---
2	---	---	None	---
3	---	---	None	---
4	1-4	---	None	---
5	1-4	2-5	preliminary	---
6	1-4	3-6	preliminary	---
7	1-4	4-7	preliminary	---
8	1-4	5-8	preliminary	---
9	1-4	6-9	preliminary	---
10	1-4	7-10	preliminary	---
11	1-4	8-11	preliminary	---
12	1-4	9-12	normal	---
13	2-5	10-13	normal	---
14	3-6	11-14	normal	---
15	4-7	12-15	normal	Avg min 5-14
16	5-8	13-16	normal	Avg min 5-14
17	6-9	14-17	normal	Avg min 5-14
18	7-10	15-18	normal	Avg min 5-14
19	8-12	16-19	normal	Avg min 5-14
20	9-13	17-20	normal	Avg min 5-14

### 6.3 Comparing the Hourly and Real-Time Values

The chart below shows data collected by an E-BAM over a two day period. The unit is set for a real-time average of 5 minutes. The 5 minute data predicts the hourly values, and is very responsive to sudden spikes in concentration, but the noise band (and thus the detection limit) of the 5 minute data is high enough to make it generally unsuitable in concentrations below about 40 micrograms. The average of the 5 minute data over these two days is 34.2  $\mu\text{g}$ , and the average of the hourly data is 34.8  $\mu\text{g}$ . Remember that the hourly data values represent air actually sampled during the *previous* hour.

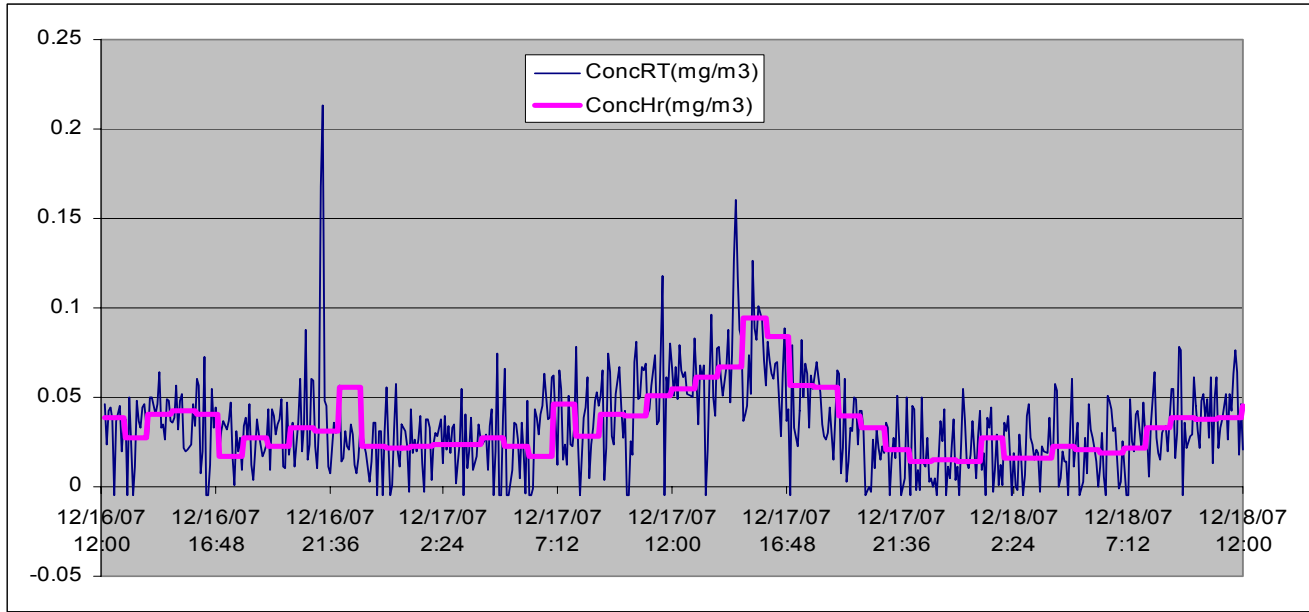

The chart below shows the same data collected over the same two day period by the same E-BAM, only this time the real-time average period was set to 15 minutes. The real-time values still predict and trend the hourly values, but the noise band of the RT values is improved, making the 15 minute data useful at lower concentrations. The average of the 15 minute data over these two days is 34.4  $\mu\text{g}$ , and the average of the hourly data is 34.8  $\mu\text{g}$ .

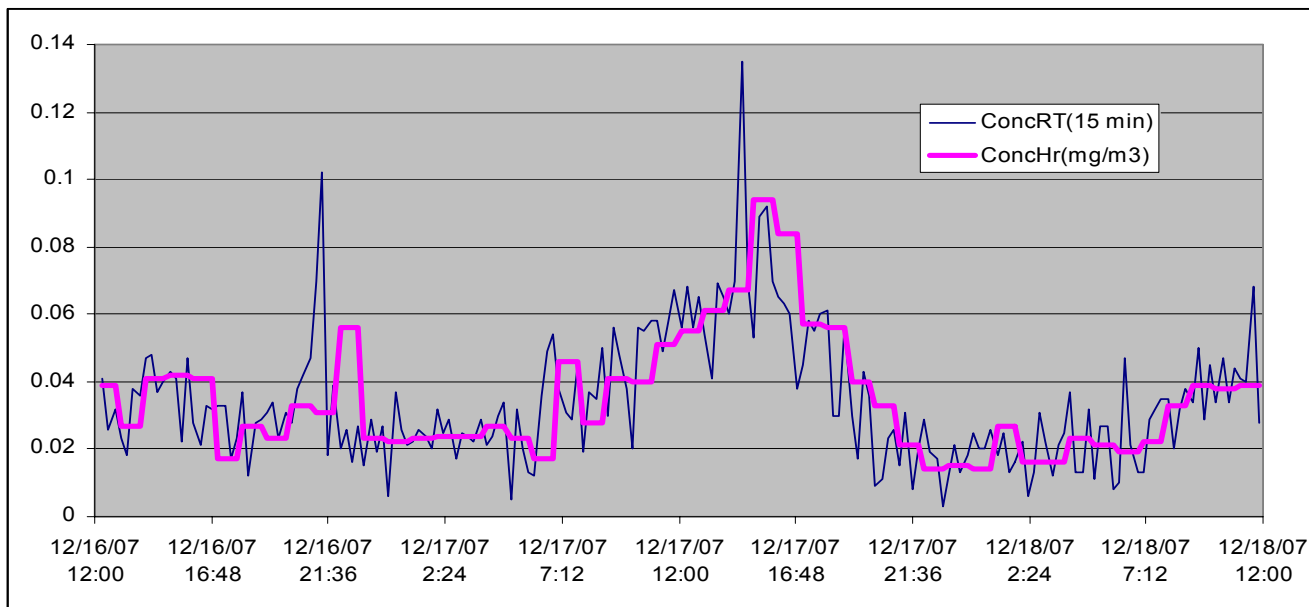

## 7 SETUP MENU DESCRIPTIONS

The E-BAM has a system of setup menus which contain all of the settings and parameters needed to perform the measurement and operation of the unit. Many of these settings are set at factory default values which are correct for most applications, but may be altered by the operator to suit the specific needs of your monitoring program. This section describes the SETUP menu in detail, and should be reviewed to ensure desired operation. Once set, most of the values in the SETUP menu will not need to be changed by the site operator. The settings will not be lost if the unit is unplugged or powered down.

The SETUP menu is located in the main E-BAM menu. Use the arrow keys to select the SETUP option in the main menu, then press the MENU/SELECT key to enter the setup menu. **Note: Some of these setup screens are the same ones that the E-BAM automatically prompts you to verify each time you power the unit up.** When entered, the SETUP menu will guide you through each of the following screens in a sequential manner.

### 7.1 The Clock Setup Screen

When the SETUP menu is entered, the clock setup screen is displayed first as shown below. If you need to change the time or date, use the arrow keys to change the values, then press SET. Press CONTINUE when finished, or to go on without making changes.

```
19-NOV-2008  16:36:42
SET           CONTINUE
```

### 7.2 The Tape Advance and Real-Time Average Setup Screen

The unit will next display the average period setup screen shown below. This menu is important to understand. If the settings need to be changed, select the parameter to be changed with the ◀▶ keys, and modify the settings with the ▲▼ keys and press SAVE. Press CONTINUE when finished, or to go on without making changes.

```
LOCATION:      01
TAPE ADVANCE: ▼24 HRS
REALTIME AVG: ▼10 MIN
SAVE         CONTINUE
```

**LOCATION** is an ID number which will appear in the data array to indicate which unit collected the data, and to enable tracking of measurement information. This is used instead of a UNIT ID because the E-BAM is portable. This may be any number from 01 to 99.

**TAPE ADVANCE** is how often the E-BAM will automatically advance to a new spot of filter tape. This value can be set to 1, 2, 3, 4, 6, 8, 12, or 24 hours. The default setting is 24 hours for maximum tape life. The unit will override this setting and automatically advance the filter tape if the concentration is too high and the filter tape becomes clogged. If the filter tape is advanced due to

high concentrations, an alarm will be recorded in the alarm log. **Note:** the tape advance setting does not change how often the concentration is calculated or stored.

**REALTIME AVG** is the averaging period for the real-time concentration value. The real-time concentration measurement is updated every minute (see Section 6.2). The REALTIME AVG is the mean of these real-time values over the selected time period. The REALTIME AVG may be set to the following time periods: 1, 5, 10, 15, 30, or 60 minutes. The following are some Important notes about the REALTIME AVG setting:

- The E-BAM always measures and stores a separate hourly concentration measurement *regardless of how the REALTIME AVG is set*. For this reason, it is usually not useful to set the REALTIME AVG to 60 minutes also.
- **The hourly measurement is always the most accurate concentration data!** The real-time data function is intended for trending purposes only.
- The shorter the average period is (such as 5 minutes), the noisier the real-time data will be. This is because very little particulate is typically sampled in such a short amount of time, resulting in a poor detection limit. The 1 and 5 minute real-time averages are intended only for smoke plume tracking in extremely high concentrations.
- Because the real-time averages are a completely separate measurement from the hourly measurement, taking an hourly average of the real-time averages might not result in an exact to the E-BAM hourly measurement taken over the same time period.
- The shorter the REALTIME AVG is set, the faster the E-BAM memory is filled up. If the real-time average is set to 60 minutes, the memory will last 182 days before the oldest data is overwritten. If a 1 minute real-time average is selected, the E-BAM memory will be filled up in just three days!
- The REALTIME AVG setting also sets the averaging period for the internal datalogger for the meteorological sensors, such as a wind sensor. Some wind sensor applications require the shorter average periods.
- For ambient monitoring in normal concentrations, a 10 or 15 minute REALTIME AVG is recommended. This is a good balance between time resolution, accurate measurements, and memory capacity.

### 7.3 The MACHINE TYPE PM<sub>10</sub>/PM<sub>2.5</sub> Setup Screen

After the real-time settings are verified, the E-BAM will go on to display the MACHINE TYPE setup screen. If needed, change the setting with the arrow keys and press SAVE. Press CONTINUE when finished or to go on without changes:



**MACHINE TYPE** simply tells the E-BAM which type of inlet it is equipped with, PM<sub>2.5</sub> or PM<sub>10</sub>. *The only difference between the two is whether a PM<sub>2.5</sub> cyclone is installed or not.* The E-BAM will put the machine type setting onto the data array, so that you can tell if the collected data was PM<sub>2.5</sub> or PM<sub>10</sub>. The screen refers the user to a picture located inside the door of the E-BAM for easy identification of the two possible inlet types.



## 7.4 The Analog Output Setup Screen

The next screen is the analog output setup menu. This screen contains the settings for the voltage output, when the E-BAM is used with an external analog datalogger. See Sections 5.8 and 9.1. Use the arrow keys to edit the values, then press SAVE. Press CONTINUE when finished, or to go on without changes.

```
ANALOG FS:▼1.0 V
          MODE:▼HOURLY
REF DAC FS:▼ 8.0 V
SAVE          CONTINUE
```

**ANALOG FS** is the setting for the desired full-scale range of the E-BAM analog output voltage. This can be set to **1.0**, **2.5**, or **5.0** volts. The analog output will then have a range from zero up to the selected voltage. The default setting is 1.0 volts, so that 0.000 to 1.000 volts equals 0.000 to 1.000 mg/m<sup>3</sup> concentration on the output. **Note:** The analog output concentration range is always 0.000 to 1.000 mg/m<sup>3</sup> regardless of the full scale voltage setting. Concentration values higher than this range must be downloaded from the digital data file.

**MODE** sets whether the HOURLY or the REAL TIME concentration is represented on the analog output. If this is set to HOURLY, the voltage output will hold constant at the previous hourly concentration value. If this is set to REAL TIME, the analog output will update based on the REALTIME AVG setting; for example every 10 or 15 minutes.

**REF DAC FS** is the digital-to-analog system rail voltage. This is factory-set and will never be changed unless instructed by Met One technicians. Default is 8.0V for all new E-BAMs. Only older units were set to 10.0V.

## 7.5 The Serial Port Setup Screen

Next is the serial port setup screen. This is used to select the baud rate for the E-BAM digital RS-232 serial port. The E-BAM baud rate can be set to **300**, **600**, **1200**, **2400**, **4800**, **9600**, **19200**, or **38400** baud. Use the fastest baud possible, while still able to communicate reliably with the computer. The 9600 baud setting is the default and is adequate for most applications. Settings slower than this are almost never used. Use the arrow keys to edit the values, then press SAVE. Press CONTINUE when finished, or to go on without changes.

**Note:** When a computer is connected to the E-BAM for digital data retrieval, it will need to be set to the same baud rate as the E-BAM or communication will not occur.

```
SERIAL PORT
BAUD RATE:▼9600

SAVE          CONTINUE
```

## 7.6 The RH Control Setup Screen

Next is RH control setup menu. These settings determine how the inlet heater is used to control the RH of the sample air stream. Use the arrow keys to edit the values, then press SAVE. Press CONTINUE when finished, or to go on without changes.

```
RH SETPOINT: 045 %  
DELTA-T SETPT: 20 C  
RH CONTROL: ▼ON  
SAVE          CONTINUE
```

**RH SETPOINT** is the threshold at which the E-BAM turns on the inlet heater to limit the RH of the sample air. This can be set from 0 to 100%. When the sample RH exceeds this setpoint, the inlet heater turns on to drive down the humidity through mild 15 watt heating. When the RH drops 1% below the setpoint, the heater turns off. The default setting is 45%, which is adequate for many applications. If the sample RH levels exceed this level, moisture can be absorbed by the particulate on the filter tape and measured as mass. This causes errors in the particulate measurement. A lower set point such as 35% is often used to further reduce the potential for sample RH effects, although this results in some additional power consumption due to longer heater cycles.

**DELTA-T SETPT** The Delta Temperature Setpoint is a parameter which overrides the RH SETPOINT. The sample air stream is heated whenever the inlet heater is turned on, in order to reduce sample RH. If the sample air temperature exceeds the ambient air temperature by more than 1 degree above this setpoint, the inlet heater is turned off regardless of the sample RH level. This is used in areas with high volatile compound levels in order to prevent overheating of the sample, particularly when the TAPE ADVANCE is set to 24 hours. The value can be set from 0 to 20 degrees C. The default is 15 C which is adequate in most applications. If this value is set to 0 C, then the inlet heater will be virtually disabled.

**RH CONTROL** is the ON/OFF setting for the inlet heater. If this is set to OFF, the heater is disabled entirely to save power. When this is set to ON, the heater is governed by the above parameters for RH and Delta-T. **Note:** If the RH CONTROL is set to ON, but the filter RH sensor fails, then the E-BAM will stop operation and generate an alarm. Also, any time the pump turns off, the heater will also turn off to save power.

## 7.7 The Flow Rate and Flow Type Setup Screen

Next is the flow setup screen. This is where the airflow settings for the E-BAM are located. Use the arrow keys to edit the values, then press SAVE. Press CONTINUE when finished, or to go on without changes.

```
FLOW  
SETPOINT: 16.7 LPM  
TYPE: ▼ACTUAL  
SAVE          CONTINUE
```

**FLOW SETPOINT** is the airflow rate at which the E-BAM will regulate for all sampling. The E-BAM is designed to operate at 16.7 liters per minute (l/min or lpm). This is important, because the PM<sub>10</sub> inlets and PM<sub>2.5</sub> sharp-cut cyclones require this flow rate in order to separate the correct sizes of

particles from the air stream. The flow setpoint value can be set to other flow rates from **10.0** to **17.5** lpm, primarily for testing the pump capacity or for special applications.

**TYPE** is the flow type setting which determines what flow conditions are reported by the E-BAM. This can be set to either ACTUAL or STANDARD flow. All E-BAM units have a mass airflow sensor, barometric pressure sensor, and ambient temperature sensor, so the unit can be set for either type of flow. The flow types are described below:

#### **STANDARD Flow Control:**

STANDARD flow type is often selected when required by specific EPA monitoring regulations, such as PM<sub>10</sub> reporting. At low altitudes and moderate temperature, standard flow can be very close to the actual volumetric flow rate. At high altitudes or extreme temperatures the difference between standard and actual flow will be very significant.

- Because the E-BAM has ambient temperature and pressure sensors, the flow rate will be controlled to *actual conditions*, but reported in standard conditions, meaning that the volume of air is calculated with the assumption that the ambient temperature is 0, 20, or 25 degrees C (user-selectable), and the barometric pressure is 760mmHg, regardless of the actual temperature and pressure.
- The concentrations will be reported in standard conditions (based on the standardized air volume).
- The flow is designated on the display as “SLPM”.
- The flow rate in the Flow Test and Pump Test field calibration screens will also be controlled to standard conditions.

#### **ACTUAL Flow Control:**

ACTUAL (volumetric) flow type is the most accurate flow control mode, and is required for all PM<sub>2.5</sub> monitoring. The actual flow type is also the easiest and fastest to calibrate and audit. The unit uses actual ambient air temperature and barometric pressure to calculate the flow rate, and the flow rate is continuously and automatically adjusted to correct for changes in ambient conditions and filter loading.

- The flow values will be *controlled and reported* in actual conditions.
- The concentrations will be reported in actual conditions (based on the actual air volume).
- The flow is designated on the display as “LPM”.
- The flow rate in the Flow Test and Pump Test field calibration screens will also be controlled to actual conditions.

### **7.8 The Ambient RH Sensor Setup Screen**

The next setup screen asks you if the E-BAM is equipped with an external (ambient) RH sensor, such as the EX-593. Most applications do not use the ambient RH sensor. If the RH sensor is to be connected to the E-BAM, use the arrow keys to set this field to YES, then SAVE and continue. This setting determines if the E-BAM will attempt to validate the sensor by monitoring its output voltage.

**Note:** If an RH sensor is not connected to the input, but the setting is set to YES, then the E-BAM will measure the floating input voltage, assume the sensor has failed, and generate an alarm.

```
EXTERNAL
RH CONNECTED: ▼NO
SAVE          CONTINUE
```

### 7.9 The Pump Protection Setup Screen

The next setup screen is the pump protection setting. If this field is set to ON, the E-BAM will automatically turn the pump off and shut down any time the ambient temperature exceeds 48 degrees C. The pump will then remain off until the temperature drops back below 45 degrees C. This can slightly extend the lifetime of the internal DC vacuum pump in certain environments. This feature should always be set to OFF unless recommended by a Met One technician, in order to avoid sample interruptions.

```
PUMP PROTECT: ▼OFF
SAVE          CONTINUE
```

### 7.10 The Restart Voltage Setup Screen

Next is the setup screen for the DC power input restart voltage. This is an important parameter to understand if the unit is to be run on batteries or solar power. The E-BAM will automatically shut down when the external battery voltage (input voltage) drops to 10.0 volts. Then the MINIMUM RESTART VOLTAGE is *the lowest input voltage at which the E-BAM will resume functioning after this shutdown*, such as after the battery has been recharged or replaced. This can be set anywhere from 10.0 to 15.0 volts. This allows the batteries enough time to adequately recharge before the E-BAM turns back on, particularly when used with a solar panel array, and prevents the unit from rapidly cycling on and off when the batteries are low. If unsure, set this parameter to 12.0 volts for most applications. Consult your battery documentation for the optimal recharge profile. Use the arrow keys to change the setting, then press SAVE and CONTINUE.

```
MINIMUM RESTART
VOLTAGE: 12.0V
SAVE          CONTINUE
```

### 7.11 The STANDARD Temperature Setup Screen

Next is the standard temperature setup screen. This setting is the temperature value that will be used to calculate the flow volume whenever the unit is set to STANDARD flow type. This can be set to **25**, **20**, or **0** degrees C. In the United States, 25C is almost always used for standard temperature. Some other countries use 20 or zero degrees instead. If the E-BAM is set to ACTUAL flow type, the unit will ignore this setting and use the actual ambient temperature for the flow calculations.

```
STANDARD CONDITIONS
TEMPERATURE: ▼25 C

SAVE          CONTINUE
```

### 7.12 The Span Membrane Setup Screen

Next is the BAM span calibration setup menu. These are the parameters that govern the reference membrane span test. These should already be set to the correct factory-determined values for your particular E-BAM. The values can be changed with the arrow keys, then saved. **Note:** The SAVE soft-key can be changed to DEFAULT using the arrow keys. Pressing the DEFAULT key will revert these settings back to the factory-set parameters in the event that they are accidentally changed. Press CONTINUE when finished.

```
BAM Calibrate
ZERO: 0.350 mg/cm2
SPAN: 0.832 mg/cm2
▼SAVE          CONTINUE
```

**ZERO** This value is set to a default of 0.350 mg/cm<sup>2</sup>. This value is not used by the E-BAM.

**SPAN** is the expected value of the span membrane foil used for the span test. Each membrane foil has a unique mass, but typically the value is around 0.800 mg/cm<sup>2</sup>. The mass of the membrane which was included with the E-BAM should already be entered here. This field is editable in case the user needs to replace the membrane assembly, or if a different membrane is used for a special application. This is sometimes called the “ABS” value.

**This is the end of the SETUP menu system. The E-BAM will exit to the main menu when finished.**

## 8 MAINTENANCE and TROUBLESHOOTING

This section provides information about routine maintenance of the E-BAM, and for performing more detailed diagnostic tests if a problem is encountered. The E-BAM often generates error messages on the display or in the data log if a failure or other problem is detected. Many times there is a simple solution, but persistent errors often signify a failure which will require investigation. The E-BAM error codes are described in this section.

### 8.1 E-BAM Error Displays, Error Logs, and Error Codes

The E-BAM contains a comprehensive system of error and alarm codes which are used to alert the operator of any problems with the unit. These error codes may be generated during normal operation, during a self-test routine, or when the E-BAM attempts to start a new sample cycle.

The errors appear on the E-BAM display, and are also stored in the digital error log as a detailed record of the time and type of the error. In addition, errors are stored in the digital data log as a code number in the data array, and are reported on the analog concentration output as a full-scale voltage. A single dry contact closure relay output is also provided to indicate an unspecified error to external devices such as alarms or dataloggers.

The following table describes each of the error and alarm types which can be generated by the E-BAM, along with the conditions which cause the alarms. Most of these alarms indicate critical parameters which must be working correctly for machine operation.

Alarm/Error Message	Alarm Description
<b>POWER OUTAGE</b>	<p>This alarm message indicates that the E-BAM power has been cycled off and then back on. This can mean that there was a power failure or that someone simply unplugged the unit to turn it off. The E-BAM alarm display will show an OFF time indicating how long the power was off, and an ON time indicating how long the power was on before the power failure.</p> <p>A second type of power alarm can be shown on the display as a COP RESET. This means "Computer Operating Properly", and will only occur when the E-BAM firmware is flash updated by the user. This is normal and does not indicate a failure.</p>
<b>INTERNAL HARDWARE</b>	<p>This alarm indicates that there was an internal SPI bus failure, preventing the CPU from communicating with the I/O board for 10 seconds or more. The time and date of the error will be displayed. The E-BAM will stop operation until internal communication is restored. If these errors occur regularly you will need to contact the Met One Service Department.</p>
<b>NOZZLE FAILED UP or NOZZLE FAILED DOWN</b>	<p>This alarm indicates that the E-BAM attempted to move the nozzle gearmotor up or down for 20 seconds, but did not sense the nozzle motor reaching the up or down position. The motor has a single-slot encoder disk on its shaft which triggers a separate photo sensor when the motor is in the up or down position. This alarm could mean that the motor has failed, or that the photo sensors have failed or are out of alignment. The E-BAM will stop operation until the nozzle is functional. The time and date of the error will be displayed.</p>
<b>SHIPPING DEVICE INSERTED</b>	<p>This alarm indicates that the zero membrane shim (also called the nozzle shipping shim) is inserted under the nozzle. The alarm will be generated if the shim is left in place during the startup process, or if it is detected when the E-BAM attempts to start an operation cycle. The unit senses the shim with a photo sensor which is triggered by the tab on the shim which extends through the transport plate when it is inserted. The E-BAM cannot operate with the shim in place.</p>
<b>TAPE BROKE</b>	<p>This alarm indicates that the tape is broken or has run out. The E-BAM has a motor which drives the left (take up) reel. The right (supply) reel has a clutch and an encoder. If the E-BAM drives the take up reel motor for 20 seconds but senses no corresponding rotation of the supply reel, the error is generated and the E-BAM will not operate. The time and date of the error will be displayed.</p>

<b>BETA COUNT FAILED</b>	This alarm indicates that the beta count signal was less than the minimum of 40,000 counts in a 1 minute period, during either a self-test or during normal operation. This can indicate that the beta detector window is dirty or obstructed, or that the detector has failed. The E-BAM will not operate until the count rate is above the threshold. The display will show the actual count total, and the time and date of the error. If the error cannot be fixed by cleaning the detector window, you will need to contact the Met One Service Department.
<b>PRESSURE SENSOR FAILED</b>	This alarm indicates that the internal barometric pressure sensors did not pass the static or dynamic criteria during the self-test process. The alarm is generated if the ambient and the filter pressure sensors are not within 2% of each other with the pump off, or if they are within 5% of each other with the pump on. The alarm display will show the INLET (ambient) pressure and the FILTER pressure, as well as the time and date of the error. Frequent alarms of this type generally indicate that one of the two digital pressure sensors inside the unit has failed. Contact the Met One Service Department.
<b>FLOW FAIL or FLOW OUT OF REGULATION</b>	This alarm indicates that the flow system failed one of two criteria during operation. The regulation alarm will be generated if the E-BAM flow is more than 0.4 lpm out of regulation for more than 5 minutes. If the 5 minute rolling average of the flow (checked once per minute) is less than 5.0 lpm or greater the 19.6 lpm, the failure alarm will be generated and the E-BAM will stop operating and attempt to auto restart. The alarm display will show the actual flow rate and the time and date of the error.
<b>MEMBRANE FAILED</b>	This alarm indicates that the E-BAM failed the manual span membrane test. This occurs if the mass measurement of the span foil does not match the expected value within 5%. The time and date of the error will be displayed. Press the down arrow key to view the measured span mass from the test. This can be compared to the known mass of the foil. Also shown is a zero reading which is not used. The Z and S values are also available in the error log download file. This alarm can indicate that the membrane is dirty or damaged, that the beta detector window is dirty or damaged, or that the detector tube is failing.
<b>LOW BATTERY</b>	This alarm indicates that the DC input voltage dropped below 10.0 volts, which is the minimum operating voltage for the unit. The E-BAM will stop operation and will not restart until the voltage is back above the user-selected restart threshold. The time and date of the error will be displayed, along with the actual voltage.
<b>HIGH TAPE DELTA-PRES</b>	This alarm indicates that the pressure drop across the filter tape has exceeded the maximum allowable limit, due to heavy particulate loading on the filter tape during normal operation. The E-BAM will stop sampling, advance the filter tape to a fresh spot, then resume sampling. The alarm display will show both the measured DELTA-P pressure drop, and the LIMIT value in mmHg. The time and date of the alarm will be displayed. The alarm can also be generated if the pressure drop exceeds a lower max limit while the ambient temperature is above 38 degrees C. If these alarms occur frequently, set the TAPE ADVANCE to a shorter interval.
<b>HIGH DELTA TEMPERATURE</b>	This alarm indicates that the delta temperature (filter temperature minus ambient temperature) of the unit exceeded the allowable setpoint by more than 1 degree C while the unit was sampling and RH control was enabled. The E-BAM will turn the heater off. The alarm display will show the measured DELTA-T value and the set LIMIT value. The time and date of the alarm will be displayed. This alarm is generally ignored.
<b>PUMP OVER TEMP</b>	This alarm indicates that the internal DC pump was turned off because the ambient temperature exceeded 48 degrees C while the unit was sampling with the pump protection feature enabled. The E-BAM will not resume sampling until the temperature drops below 45 degrees. The display will show the ambient temperature and the time and date of the error. This feature can be used to prevent the pump from wearing out early due to high temperature operation, but is almost always just disabled in the SETUP menu.
<b>SENSOR FAILURE</b>	This alarm indicates that one of the sensors in the unit is not responding, or is measuring a value outside of its specified range. The display will show the time and date of the alarm, the type of sensor which has failed, and the faulty measurement from the sensor. The E-BAM will not operate until the sensor is operational. The most common sensor failures occur if the ambient temperature sensor is disconnected from the E-BAM, or if the filter RH sensor or one of the digital pressure sensors fail. The error can also occur if the SETUP menu has been set to expect an ambient RH sensor which is not connected. If the error occurs even though the indicated sensor is connected correctly, you will need to contact the Met One Service Department.

The following are some examples of how the alarm and error records appear when shown on the main E-BAM display as a current error or, when viewed as a historical error record in the user interface system:

16-DEC-2008 16:25:20 POWER OUTAGE OFF: 0.00:02:10 ON: 5.06:05:31	16-DEC-2008 16:25:20 BETA COUNT FAILED 15461	16-DEC-2008 16:25:20 FLOW FAIL FLOW: 15.7 LPM
16-DEC-2008 16:25:20 TAPE BROKE!	16-DEC-2008 16:25:20 HIGH TAPE DELTA-PRES DELTA-P: 300.1 mmHg LIMIT: 266.7 mmHg	16-DEC-2008 16:25:20 SENSOR FAILURE AT 61.0 C

The normal E-BAM digital data array also contains an “alarm” code column to indicate if there were any alarm or error flags during that particular sample period. An example of an E-BAM data record is shown below. The alarm header and alarm code are shown in bold:

```

AutoMet Data Log Report
18-DEC-2008 16:22:45,
SN,F1768

Time, ConcRT(mg/m3), ConcHr(mg/m3), Flow(l/m), WS(m/s), WD(Deg), AT(C), RHx(%), RHi(%), BV(V), FT(C), Alarm, Type
03-DEC-2008 18:00:00,0.018,0.015,16.7,0.3,0,26.4,0,34,14.2,25.8,0,1
    
```

The following table defines the possible error codes that can appear in the “alarm” column of the E-BAM data records:

Code	Error/Alarm Type
<b>0</b>	No alarm
<b>1</b>	Tape Break
<b>2</b>	Beta Count Failure
<b>4</b>	High Tape Delta Pressure (Tape Advance)
<b>8</b>	Pressure Sensor Failure
<b>16</b>	Flow Failure
<b>32</b>	Nozzle Failure
<b>64</b>	Internal Hardware (SPI bus) Failure
<b>128</b>	Low Battery
<b>256</b>	Delta Temperature Setpoint Exceeded
<b>512</b>	Pump Over Temp 48C

**Note:** If multiple errors or alarms occur in the same data period, then the alarm code stored in the data array will be the *sum of the two individual code numbers*. This is a rare occurrence.



When the digital error log is retrieved from the E-BAM using Comet software or ESCAPE commands, the error report will contain the same information about the alarms as described above, only in the following format:

```
E-BAM Error Log Report
18-DEC-2008 16:25:56,
SN,F1768

20-NOV-2008 20:00:00, Power outage: 0.00:20:17 On: 5.02:30:22
20-NOV-2008 20:00:00, Internal Hardware: CS:2 Header:0
20-NOV-2008 20:00:00, Nozzle Failed UP!
20-NOV-2008 20:00:00, Shipping device inserted!
20-NOV-2008 20:00:00, Tape broke!
20-NOV-2008 20:00:00, Beta count failed: 13357
20-NOV-2008 20:00:00, Pressure test failed: %:4.87 Inlet: 267.01 Filter: 280.02
20-NOV-2008 20:00:00, Flow failed: Setpt: 16.7 Flow: 15.2
20-NOV-2008 20:00:00, Membrane failed: Z: 0.285 S: 0.705
20-NOV-2008 20:00:00, Low battery: 9.46
20-NOV-2008 20:00:00, High Tape Delta-Pressure: 270.1 mmHg Limit: 266.7 mmHg
20-NOV-2008 20:00:00, High Delta-T: 18.1 C Limit: 15.0 C
20-NOV-2008 20:00:00, Pump Over Temp: 49.1 C Limit: 48.0 C
20-NOV-2008 20:00:00, Sensor Failure: Inlet Pressure Value: 820.0
```

In each case, the alarm log record indicates the time and date of the error, and the specific parameter which generated the alarm. The measured value of the parameter, compared to the acceptable limits, is also recorded where applicable.

## **8.2 Contact Closure Alarm Relay Output**

The E-BAM has a single channel contact closure alarm relay output available. This is used to signal an external datalogger that the E-BAM has encountered an unspecified error. The relay contacts are located on the main E-BAM power input connector (pins 3 and 4), so you will need a special power cable which has a break-out for the relay wires, as the standard power cables do not. The two relay contacts are normally closed (shorted together) when the E-BAM is operating correctly, and will open up whenever an error occurs. The relay is rated for up to 100V<sub>DC</sub> @ 0.5A max. The only alarm flags which can cause the relay output to activate are:

- Tape Broken
- Beta Count Failure
- Sensor Failure
- Pressure Sensor Failure
- Flow Failure
- Nozzle Failure
- Internal Hardware Failure
- Low Battery
- Pump Over Temperature

### 8.3 Basic Problem and Cause/Solution Table

The following table contains information on some of the more common E-BAM problems which may be encountered, and some steps to identify and remedy the problems. Met One welcomes customer suggestions for new items to include in this section of future manual revisions! If the solution cannot be found in the following table, then contact one of our expert service technicians for help in resolving your problem.

<b>Problem:</b>	<b>The E-BAM won't start a measurement cycle.</b>
<b>Cause/Solution:</b>	<ul style="list-style-type: none"> <li>• The E-BAM will not start a measurement cycle if it detects a hardware failure, such as low beta count signal, nozzle failure, pressure sensor failure, or pump failure.</li> <li>• The unit will not start a cycle if the input DC voltage is below the restart threshold, such as 10 volts DC.</li> <li>• The unit will not start a cycle if the zero membrane plate (shipping shim) is inserted.</li> <li>• The unit will not start a cycle if the ambient temperature sensor is not connected.</li> <li>• The unit will not start a cycle if the filter tape is not installed correctly.</li> <li>• The unit will usually display an error message on the display if it cannot start a cycle.</li> <li>• If the unit is left in a SETUP or FIELD CALIBRATION screen, it should still try to start a cycle after several minutes of inactivity, unless a failure is detected.</li> </ul>
<b>Problem:</b>	<b>The analog output voltage concentration readings are full-scale.</b>
<b>Cause/Solution:</b>	<ul style="list-style-type: none"> <li>• The unit will force the analog output to the full scale voltage (1, 2.5 or 5 volts) to indicate an error. Download the error log to view any possible errors.</li> <li>• The full-scale analog output is usually scaled to represent 1.000 mg/m<sup>3</sup>. If this concentration is recorded by an external datalogger which is measuring the E-BAM analog output, then either there is an error in the E-BAM, or the particulate concentrations have exceeded the range of the analog output.</li> </ul>
<b>Problem:</b>	<b>The E-BAM records frequent "Pressure Drop Excessive" errors.</b>
<b>Cause/Solution:</b>	<ul style="list-style-type: none"> <li>• This usually indicates that the filter tape is automatically advancing in response to being clogged due to heavy particulate loading.</li> <li>• If frequent pressure-drop errors are encountered, try setting the TAPE ADVANCE setting to a shorter interval.</li> </ul>
<b>Problem:</b>	<b>The E-BAM concentration indicates negative values.</b>
<b>Cause/Solution:</b>	<ul style="list-style-type: none"> <li>• It is possible for the unit to occasionally record negative hourly values if the actual particulate concentration is very low, such as below 3 micrograms. This is because the E-BAM has an hourly random noise band of several micrograms.</li> <li>• If the unit is reading negative numbers hour after hour, it is probably punching holes in the filter tape. These holes can be very small and hard to see. This is almost always caused by debris on the nozzle or vane. Clean the parts.</li> <li>• The real-time averages of the E-BAM (especially the 1 and 5 minute averages) are considerably noisier than the hourly measurements. These noise spikes may indicate negative concentrations unless the true concentrations are high.</li> <li>• The noise performance of the E-BAM may be audited. Met One supplies the BX-302 zero filter kit for auditing the zero readings of the unit.</li> </ul>
<b>Problem:</b>	<b>The airflow won't regulate at the correct rate of 16.7 lpm.</b>
<b>Cause/Solution:</b>	<ul style="list-style-type: none"> <li>• This usually indicates that the air pump is losing vacuum capacity due to wear.</li> <li>• The internal DC pump in the E-BAM will need to be replaced after about 6 to 9 months of continuous use. The internal DC pump cannot be rebuilt.</li> <li>• Check for leaks at the nozzle. This will often cause the inlet flow to be low even though the flow sensor is measuring the correct flow rate. This is because the flow sensor is downstream of the filter tape and nozzle. Clean the nozzle and vane.</li> <li>• The standard version of the E-BAM regulates the internal pump by pulse-width modulation. There are no valves or flow controllers inside the unit.</li> <li>• Perform a flow calibration. If the flow regulates at the lower calibration point, but not</li> </ul>

	<p>the higher point, the pump is probably worn out or there is a leak.</p> <ul style="list-style-type: none"> <li>• The gray plastic pump mufflers used on the Medo pump (external pump models only) clog up after several months. Replace it or drill a hole in the end of it.</li> <li>• External pump box models <u>do</u> have a flow controller inside the pump box.</li> <li>• Check the inlet and PM heads for obstructions.</li> <li>• The E-BAM pump may have difficulty regulating to 16.7 lpm under certain circumstances at very high altitudes due to the thin air.</li> </ul>
--	---

<b>Problem:</b>	<b>The nozzle gets stuck in the UP position, or won't press down onto the tape fully.</b>
<b>Cause/Solution:</b>	<ul style="list-style-type: none"> <li>• The nozzle o-ring eventually breaks down and needs to be replaced. Contact Met One for detailed instructions. No special tools are required.</li> <li>• With the nozzle down, lift it with your fingers and determine if it feels sticky or gritty. This often indicates that the nozzle o-ring needs to be replaced.</li> <li>• The nozzle motor lifts the nozzle with a cam, but the nozzle is lowered by the spring compression only. The nozzle is not driven down. The E-BAM monitors the nozzle motor position with photo sensors, but it is possible for the nozzle itself to become stuck in the up position, even if the motor is working and there are no alarms.</li> <li>• If the nozzle photo sensors or the nozzle motor fails, the E-BAM should generate frequent nozzle failure alarms.</li> </ul>

<b>Problem:</b>	<b>The unit has flow leaks, even after cleaning the nozzle and vane.</b>
<b>Cause/Solution:</b>	<ul style="list-style-type: none"> <li>• The nozzle may be sticking as described above. Verify that the nozzle up/down motion is smooth and complete. If the nozzle feels sticky or gritty, it will not seal properly.</li> <li>• Check the o-rings on the sharp-cut cyclone (if used). These frequently leak.</li> <li>• Check for bad o-rings on the E-BAM inlet receiver.</li> <li>• Make sure the two fittings on the ends of the short internal tube are seated correctly. This is the short tube directly above the nozzle assembly. It is sealed with o-rings</li> <li>• The E-BAM transport assembly may be removed from the enclosure to inspect the air fittings inside the unit. This should only be done after all other leak points up stream of the vane are eliminated as possibilities.</li> </ul>

<b>Problem:</b>	<b>The unit over-measures or under-measures concentrations compared to a collocated FRM filter sampler.</b>
<b>Cause/Solution:</b>	<ul style="list-style-type: none"> <li>• Moisture may be getting onto the filter tape or being absorbed by the particulate. Review the inlet heater settings for proper operation.</li> <li>• Test the filter RH sensor calibration, and download the RH<sub>i</sub> values. The filter RH should be effectively controlled to the setpoint, typically 45%.</li> <li>• Verify the flow rate and temperature and pressure calibrations.</li> <li>• Check for leaks at the nozzle. A leak can cause either a positive or a negative measurement bias depending if the air leaking around the nozzle is cleaner or dirtier than ambient air.</li> <li>• Verify the collocation setup requirements, especially making sure the inlets are spaced correctly and the same height.</li> <li>• If the analog output of the E-BAM is being logged by an external datalogger, make SURE the logger's scaling of the E-BAM output is correct! A 0.000 volt <u>analog output</u> on the E-BAM equals 0.000mg. There is no -0.005 or -0.015 offset value in the E-BAM analog output, unlike the BAM-1020! See Section 7.4. Periodically verify that the digital data log from the E-BAM matches the external logger data.</li> <li>• Perform a 48-hour BX-302 zero filter test to verify the average zero reading. If the average is not close to zero, it can appear as an offset of several micrograms in the E-BAM concentration data. The background value cannot be edited in the E-BAM without special instructions. Contact Met One.</li> <li>• Single event FRM samplers often perform better than multi-channel FRM samplers. If a multi-channel unit is used, then filter collection should still be performed on a daily basis. If the FRM filters are not properly collected and retained every day, then correlation results with the E-BAM can suffer.</li> <li>• Make sure that no error-flagged hours are included in your 24 hour E-BAM</li> </ul>

	<p>averages.</p> <ul style="list-style-type: none"> <li>Sometimes very large particles can become stuck inside the E-BAM nozzle where the air flows around the beta source. This can cause slight under-reporting of TSP concentrations under certain atmospheric conditions. Do not disassemble the nozzle! It must be cleaned with compressed air only. Section 8.6.</li> </ul>
--	---

<b>Problem:</b>	<b>The unit will not pass the span membrane test.</b>
<b>Cause/Solution:</b>	<ul style="list-style-type: none"> <li>This often just indicates the membrane foil surface is dirty or damaged. It can be cleaned with water rinse. Damaged membranes must be replaced.</li> <li>If the membrane is in good condition, but the unit fails span tests, then the most common problem is debris on the beta detector window. Carefully blow through the vane with canned dusting air to blow debris off of the detector window and try again.</li> <li>Newer E-BAM beta detectors can be removed and cleaned. Older detectors cannot be cleaned or damage will result. Consult Section 8.7 of this manual about cleaning the detector before attempting to remove it from the E-BAM.</li> <li>If the detector is clean and the membrane is in good condition, then failed span tests can indicate that the detector is wearing out. Contact the Service Department.</li> </ul>

<b>Problem:</b>	<b>The clock settings are lost when the unit is powered down.</b>
<b>Cause/Solution:</b>	<ul style="list-style-type: none"> <li>There is a large lithium battery inside the unit which maintains the clock and other settings when the unit is powered off. After several years the battery may need to be replaced if the clock resets when the E-BAM is powered off.</li> <li>The lithium battery may simply have become unplugged from the 3210 board. The battery is a black module inside the E-BAM which is retained with a strip of hook-and-loop material. It has a two-wire harness.</li> <li>It is normal for the clock to drift as much as 2 minutes per month.</li> </ul>

## 8.4 Met One Suggested Periodic Maintenance

The following table shows the Met One recommended periods for routine maintenance items. Some of these items will need to be performed more or less often depending on the exact characteristics of your location. The program administrator should review these items and establish SOPs appropriate for your application.

Maintenance Item	Suggested Period
Replace the filter tape (depends on the TAPE ADVANCE setting)	As needed
Leak check	Monthly
Nozzle and tape vane cleaning	Monthly
Flow audit (and calibration if needed) including ambient temperature and pressure	Monthly
Clean PM10 inlet particle trap	Monthly
Clean PM2.5 cyclone particle trap	Monthly
Check error log	Monthly
Download digital data log	Monthly
Set the E-BAM clock	Monthly
Span membrane test	Monthly
Clean the inside of the sample nozzle with compressed air	2 Months
Check pump capacity	2 Months
Replace the pump muffler (external pump box versions only)	6 Months
Test filter RH and filter temperature sensors	6 Months
Test analog output voltage (if used)	6 Months
Replace internal DC vacuum pump (or as needed)	12 Months
Rebuild AC pump (external pump box versions only)	24 Months
Factory recalibration. Not required except for units sent in for major repairs.	---

## **8.5 DC Pump Replacement**

The internal DC dual diaphragm pump used in the standard version of the E-BAM is one of the smallest and lowest power consuming models available which can still maintain a 16.7 lpm flow rate under load. The pump is rated for at least 4000 hours of operation under normal conditions. The typical area of wear on these pumps are the motor brushes and motor bearings. The pump is not rebuildable, so it will need to be replaced approximately every 6 to 9 months of continuous operation when it can no longer regulate at the normal 16.7 lpm flow rate. The exact lifetime of the pump will vary depending on concentration levels and ambient temperatures. The E-BAM is designed for fairly easy pump replacement without having to remove the transport assembly from the enclosure. Consult the Service Department if difficulty is encountered.

1. Turn off power from the E-BAM before accessing the pump.
2. Remove the two 8-32 screws which fasten the pump cover plate. Unplug the door switch harness which is mounted in the cover plate and set the plate aside.
3. Remove the two small screws which fasten the small clear plastic cover in front of the vertical sample tube. Set the parts aside.
4. Remove the vertical sample tube and inlet heater assembly by sliding the two sealing collars upward. The collars have o-ring seals and are compression fit only. Unplug the inlet heater harness and set the sample tube and heater assembly aside.
5. Unplug the pump from the J17 connector on the 3610 PCB.
6. Remove the three 6-32 screws which mount the pump assembly to the transport plate. The pump assembly will be loose except for the tube connections.
7. Unplug the four 3/8" ID tube connections from the front of the pump. Mark the tubes if necessary to make sure they are replaced in the exact same positions.
8. Completely remove the hose clamp which clamps the pump to the mounting bracket.
9. Turn the pump assembly upside down and locate the two 6-32 screws which are visible through the holes in the sheet metal bracket. Loosen but do not remove the screws. The pump should now slide away from the bracket assembly. Set aside the old pump. You may have to cut a zip tie which retains the harness.
10. Orient the new pump onto the bracket assembly and slide it into place so that the slots on the pump fully engage the two square nuts that you just loosened to remove the old pump. Tighten the two screws/square nuts securely. Make sure the pump harness is on top as shown in the drawings.
11. Reattach the hose clamp to tightly secure the pump to the bracket.
12. Reinstall the pump assembly into the E-BAM making sure the tube connections are in the same positions they were for the old pump. Fasten the three mounting screws.
13. Reinstall the sample tube heater assembly. Make sure to plug the heater back into its harness and to reposition the two sealing collars.
14. Plug the new pump harness into J17 of the 3610 PCB. Make sure the harness does not interfere with the fan blades. Replace the pump cover plate.

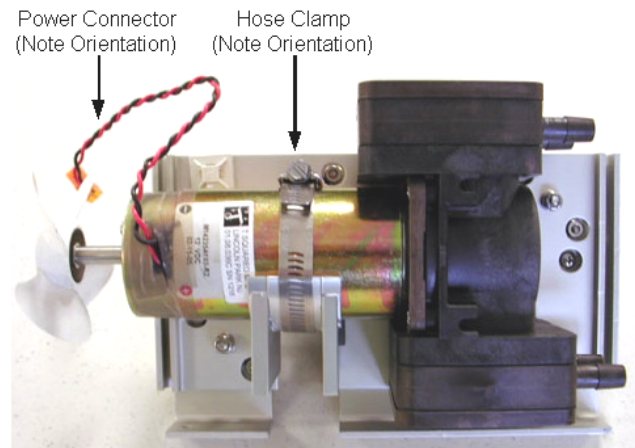
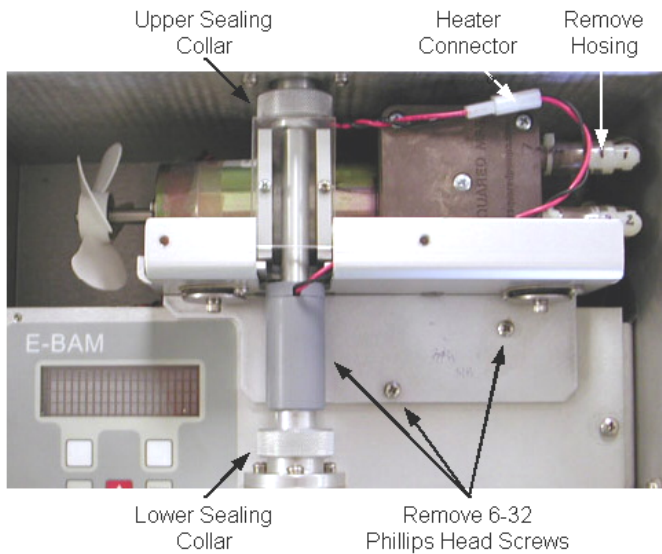

Loosen 6-32 Phillips Head Screws

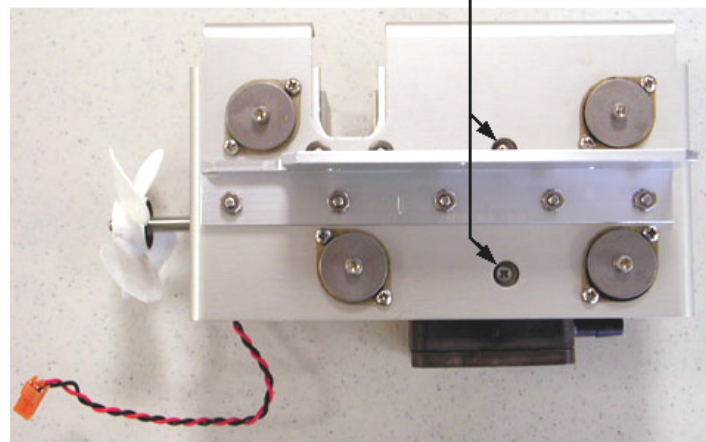

**Pump Replacement Diagrams**

## 8.6 ***Cleaning the Inside of the Sample Nozzle Assembly***

The inside of the E-BAM sample nozzle should be periodically cleaned to remove any particulate which may have settled on the inside surfaces. This cleaning prevents any buildup of particulate which could result in artifacts falling out of the nozzle and onto the tape, causing undesired positive concentration spikes. The cleaning involves blowing low pressure compressed air through the nozzle assembly only. **CAUTION: Never attempt to remove or disassemble the nozzle assembly! The beta source is housed inside the nozzle.**

1. Advance the filter tape to a fresh spot.
2. Remove the pump cover plate, clear heater cover, and sample tube/heater assembly as described above for pump removal. You now have access to the top of the nozzle assembly.
3. Use a can of dusting air with a long plastic nozzle to blow through the nozzle and filter tape. This will dislodge any particulate from the inside of the nozzle and deposit it onto the tape.
4. Repeat the process until the tape spot no longer shows signs of particulate. You may need to advance the spot to determine this.
5. Replace the sample tube and cover plates when finished.

Blow air here to clean inside the nozzle assembly

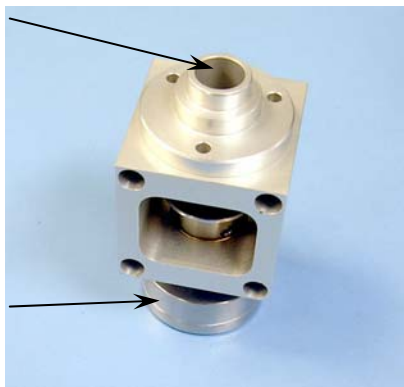

Do not disassemble the sample nozzle

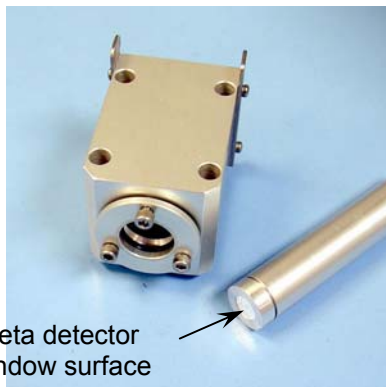

Beta detector window surface

## 8.7 Cleaning the Beta Detector Assembly

The beta particle detector in the E-BAM is located directly underneath the filter tape support vane. The entry window of the detector can occasionally become covered with a layer of fine white filter tape debris (glass fibers) or particulate deposits. This debris can reduce the beta signal to the point where the E-BAM cannot function correctly. The first attempt to clean the detector window is simply to blow canned air through the vane to dislodge the debris. This is often adequate to solve the problem. In some cases, the debris may be stuck to the detector window to the point where the detector tube will need to be removed and cleaned thoroughly. This involves removing the E-BAM transport from the weatherproof enclosure.



**Important Note: E-BAMs built before July, 2006 should never have the beta detector window touched or cleaned with any kind of solvent, unless the detector has been upgraded by Met One!** The detector window on these older units is coated with a thin reflective coating which will be badly damaged if it is rubbed or abraded in any way. The only way to clean these windows is with a very soft sable lens brush. E-BAMs built after July, 2006 (some units with serial prefix F, and all units with serial prefix G or later) have an improved detector assembly with a hardened window which may be carefully cleaned with solvent such as water or alcohol. **If you are unsure about which type of detector you have, contact the Met One Service Department before proceeding!** Use the following steps to remove and clean the detector:

1. Turn off the E-BAM power and remove the power cord. Remove any other cables or connections from the bottom of the unit.
2. Remove the pump cover plate and the vertical sample tube/heater assembly from the inside of the E-BAM.
3. Unscrew the four large screws which retain the transport plate to the inside of the enclosure. Remove the two smaller screws on the bottom of the E-BAM near the connectors.
4. Carefully remove the transport assembly from the enclosure by rocking the top of the transport out first. Be careful not to damage any wires or tubing, as the fit is tight!
5. Set the transport on a static-free flat surface.
6. Loosen but do not remove the three hex head screws in the compression collar at the base of the detector tube. The detector tube should slide out of the bottom of the flow block. Carefully pull out the detector without stressing the harness.
7. Inspect the silver window on top of the detector before doing any cleaning. Make sure the window is not broken or damaged.

8. If the E-BAM has an older style detector, *very carefully* clean the window with canned air and a soft lens brush only, but no solvent of any kind. If the E-BAM has a newer style detector, clean the window with a soft cotton-tipped applicator wet with distilled water. If water does not work, isopropyl alcohol may be used. Do not scrub the window with any force.
9. Make sure the vane area is completely clean before reinserting the detector.
10. Reinsert the beta detector into the flow block. The detector will slide up until it contacts a stop pin which will not allow the detector to go any further. **Note: It is critical that the detector be fully inserted!**
11. Tighten the three screws in the compression collar to secure the detector in place. Do not over-tighten the compression collar!
12. Replace the E-BAM transport assembly into the enclosure and fasten with the screws.
13. Power up the E-BAM and perform allow it to warm up for at least one hour. Perform a span membrane test. The unit should pass the test if the detector is working properly. If difficulty is encountered contact the Met One Service Department.

**Note:** Units which have the older style detector window can be factory upgraded with the new style detector, if the unit is located in an environment where frequent detector fouling is encountered. Contact the Service Department for details.



## 9 DATA RETRIEVAL and COMMUNICATIONS

This section describes the methods used to retrieve data files from the E-BAM. The unit has an RS-232 two-way serial port which may be used with a computer, laptop, modem, or digital datalogger. This serial port handles all digital data transfer, and can be directly connected to a computer, or can be used with an optional modem for remote communications through a phone line, cell system, radio link, or IP addressable serial converter. Access to the data through the serial port is a simple command driven interface. An analog voltage output is also available for special applications.

### 9.1 Analog Voltage Output

The E-BAM has an analog voltage output available which represents the hourly or real-time concentration values. The analog output signal is located on the same E-BAM connector as the serial data output, due to limited connector availability. The analog output is rarely used because of the portable nature of the E-BAM, so the standard E-BAM serial cable that comes with the unit does not have access to the analog output signal. If the analog output is to be used, you will need to acquire a special cable which has a breakout for the white voltage output wire (CONC signal) and the black (ground) wire as shown in the cable drawing below. These two wires are then routed to your analog datalogger input to record the output. The E-BAM analog output can be set to 0-1, 0-2.5, or 0-5 volts, which represents a fixed range of 0 to 1.000 milligrams of concentration. **Note:** Negative concentrations cannot be represented on the analog output. See Section 7.4 for details about how to set up and configure the analog output. See Section 5.8 for instructions about how to test the output voltage.

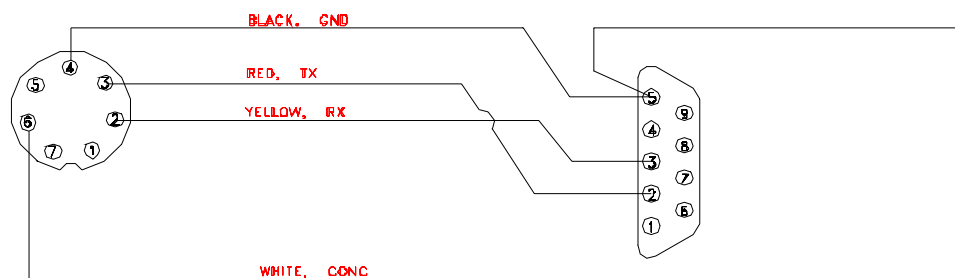

E-BAM Serial Cable Wiring, (with Analog Output)

### 9.2 Serial Port Connections to a Computer

The E-BAM can be directly connected through the supplied E-BAM serial cable to most standard desktop computers that have a 9-pin (DB-9) RS-232 serial port connector (COM1 to COM4). The E-BAM can also be connected to most laptop computers, though newer laptops do not usually have 9-pin serial ports, so a converter may have to be used. The simplest type is a USB-to-RS232 serial adapter. Met One recommends the Belkin F5U109, available from Met One or a local electronics store. You will still need the standard E-BAM serial cable. Certain laptops occasionally have difficulty communicating through this type of adapter. Another option is an RS-232 serial PCMCIA card, such as the Quatech SSP-100 which installs in an expansion card slot in the laptop and provides a serial port for the E-BAM. This type of adapter is very reliable, but more expensive and takes longer to install and configure. See [www.quatech.com](http://www.quatech.com) for more information.

The E-BAM settings are 9600 Baud, 8 data bit, no parity, one stop bit. The baud rate is a default setting which may be changed to a faster value. The other communications settings are fixed.

### 9.3 Comet™ Data Retrieval Software

The E-BAM is supplied with a CD containing a free copy of the Comet™ program, which is a simple Windows-based communications terminal program developed by Met One Instruments. This is the recommended method for all E-BAM data retrieval, since Comet allows the user to easily download the data logs, error logs, and settings (EEPROM) files from the E-BAM without the user having to know any of the underlying communications protocols. The Comet CD also contains a very comprehensive pdf user's manual for the program. Install the program onto the computer that you will be using for data retrieval, and review the manual for complete data examples. Comet replaces the obsolete TUS (Terminal Utility Software) program. **Note:** If you use Comet for E-BAM data retrieval, you will not need to use any of the terminal program setups or "AutoMet" commands shown in the following two sections of this manual.

### 9.4 Downloading Data Using HyperTerminal or other Terminal Programs

E-BAM data can also be easily downloaded through the serial port using HyperTerminal® or other simple terminal programs. Most PCs running Microsoft Windows 95® or later operating systems (except Vista®) already include the HyperTerminal program. This section describes how to set up HyperTerminal for communication with the E-BAM.

1. Connect the RS-232 port on the bottom of the E-BAM to your computer or laptop Com1 serial port using the E-BAM serial cable. A USB adapter may be required for laptops.
2. Open HyperTerminal. (Usually located in the Programs\Accessories\Communications directory). The program will ask you to type a name for the connection. Type "E-BAM" or another name of your choice, then click "OK".
3. The "Connect To" window will open. Select COM1 (or another serial port if used) from the drop-down menu in the "Connect using:" field. Click "OK". Note: You could also set up the program to dial the BAM through a modem in this window.
4. The "COM1 Properties" window will open. Set the following values in the drop-down menus, then click "Apply" and "OK".

<b>Bits per second:</b>	<b>9600 (or set to match E-BAM baud setting)</b>
<b>Data bits:</b>	<b>8</b>
<b>Parity:</b>	<b>None</b>
<b>Stop bits:</b>	<b>1</b>
<b>Flow control:</b>	<b>None</b>

5. The main HyperTerminal connection window should now be open. Press the ENTER (carriage return) key three times. The E-BAM should respond with an asterisk (\*) command prompt indicating that the terminal program has established communication with the unit.
6. Once communication is established, retrieve the desired files from the E-BAM using the appropriate "AutoMet" commands shown in the next section.
7. HyperTerminal will only display 100 lines of data in the window. To capture larger files (such as All Data), first select Transfer > Capture Text from the drop-down menu. Select a location for the file, then click the "Start" button. Retrieve the desired files, and HyperTerminal will automatically store them to the text file as they are downloaded. Click the "Stop" button in the same drop-down menu to stop the text capture when finished.
8. When you exit HyperTerminal, it will ask if you want to save your connection. Click "Yes" and a file named "E-BAM.ht" (or other connection name) will be created in the HyperTerminal folder, which will have all of the communication settings saved. You can use this connection for future communications with the unit.

**Importing the text file into a spreadsheet:** The data saved in a text file from a terminal download can be viewed by simply opening the text file. However, the data is often somewhat hard to view in the raw text format due to the comma-separated layout of the data fields. The easiest way to analyze the data is to import it as a .csv file into a spreadsheet program such as Excel®:

1. Open the text file of the data, located in the directory you selected for the text capture.
2. Delete all of the title text rows (download date, serial number, etc.) and the empty rows at the top of the file, down to the data header row which defines each of the columns of data. **Do not delete the data header row**, since you will want it to appear in the spreadsheet. There must be no blank spaces or other characters before the data header.
3. Scroll to the end of the data and make sure there are no blank spaces or empty rows after the last data record. If so, delete them.
4. Save the text file and close it.
5. Rename the file extension from .txt to .csv . This will change the file from a text file to a “comma-separated values” data file.
6. The .csv file should be able to be opened directly by Excel. Each data parameter should appear in its own spreadsheet column, with the correct data header at the top of each column. You can then save the file as a .xls or other spreadsheet file if desired.

### 9.5 “AutoMet” Data Retrieval Commands Through the Serial Port

When a serial connection between the computer terminal program and the E-BAM has been established, you will have access to the E-BAM data files by sending the following commands through serial port with keyboard strokes or ASCII characters. **Note:** After a few minutes, the E-BAM will stop waiting for a command and you will have to send another series of three carriage returns to reestablish the command prompt connection.

Command	Function
<b>2</b>	Prints <b>all records</b> in the Data Log file.
<b>3</b>	Prints all <b>new records</b> in the Data Log file since the last data download.
<b>4</b>	Prints the <b>last record</b> in the Data Log file only.
<b>5</b>	Prints all records in the Data Log file in 24 hour daily format.
<b>c</b>	Clears all records in the Data Log file.
<b>d</b>	Set date.
<b>t</b>	Set time.
<b>? or h</b>	Identifies unit type and firmware type. Example: “E-BAM 3613-01 R1.50”

The following is an example of the data response from the E-BAM after a “2” command (all data records) was sent to the unit. The report starts with a printout of the time and date of the download and the serial number of the E-BAM. Then a data header row is printed which defines each of the columns in the data field. The column are separated by commas to make it easy to import the data into a spreadsheet, or to parse out data fields in an automatic data collection system. Each column is a certain data parameter. Each row is one complete data record consisting of all stored parameters. In this example, the real-time average is set to 10 minutes, so there was a complete record stored to memory every 10 minutes. Data parameters such as wind speed/direction and external RH will always appear in the data array even if no sensors were connected for those channels. In this example, only a couple of hours worth of data was stored in the memory:

\* 2

AutoMet Data Log Report  
18-DEC-2008 16:22:36,  
SN,F1768

```
Time,ConcRT(mg/m3),ConcHr(mg/m3),Flow(l/m),WS(m/s),WD(Deg),AT(C),RHx(%),RHi(%),BV(V),FT(C),Alarm,Type
03-DEC-2008 16:40:00,0.016,0.013,16.7,0.3,0,26.2,0,33,14.2,25.5,0,1
03-DEC-2008 16:50:00,0.012,0.013,16.7,0.3,0,26.2,0,32,14.2,25.6,0,1
03-DEC-2008 17:00:00,0.015,0.018,16.7,0.3,0,26.5,0,33,14.2,25.6,0,1
03-DEC-2008 17:10:00,0.022,0.018,16.7,0.3,0,26.6,0,33,14.2,25.7,0,1
03-DEC-2008 17:20:00,0.020,0.018,16.7,0.3,0,25.2,0,32,14.2,26.3,0,1
03-DEC-2008 17:30:00,0.017,0.018,16.7,0.3,0,26.4,0,33,14.2,25.7,0,1
03-DEC-2008 17:40:00,0.013,0.018,16.7,0.3,0,26.6,0,33,14.2,25.8,0,1
03-DEC-2008 17:50:00,0.019,0.018,16.7,0.3,0,26.7,0,34,14.2,25.8,0,1
03-DEC-2008 18:00:00,0.018,0.015,16.7,0.3,0,26.4,0,34,14.2,25.8,0,1
```

If a “3” command is sent (new data records), the data response from the E-BAM is formatted as shown above, but includes only the data logged since the last time the data was downloaded, based on the position of a data pointer. This command saves time by not retrieving old data that has already been downloaded before.

If a “4” command is sent (last data record), then the data response from the E-BAM is formatted the same, except that only the latest data record in memory is printed as shown below:

\* 4

AutoMet Data Log Report  
18-DEC-2008 16:22:45,  
SN,F1768

```
Time,ConcRT(mg/m3),ConcHr(mg/m3),Flow(l/m),WS(m/s),WD(Deg),AT(C),RHx(%),RHi(%),BV(V),FT(C),Alarm,Type
03-DEC-2008 18:00:00,0.018,0.015,16.7,0.3,0,26.4,0,34,14.2,25.8,0,1
```

The following table defines the data parameters as they appear in the header of the data reports:

Field	Description
<b>Time</b>	Time and data stamp of the data record.
<b>ConcRT</b>	Real-time average concentration in mg/m3.
<b>ConcHr</b>	Last hourly concentration in mg/m3.
<b>Flow (l/m)</b>	Average air flow for the data logging period in liters per minute.
<b>WS (m/s)</b>	Average wind speed for the data logging period in meters per second.
<b>WD (Deg)</b>	Average wind direction for data logging period in degrees.
<b>AT (C)</b>	Average ambient temperature for the data logging period in °C.
<b>RHx (%)</b>	Average external RH for the data logging period in %.
<b>BV (V)</b>	Average battery or input voltage for the data logging period in volts.
<b>FT (C)</b>	Average filter temperature for the data logging period in °C.
<b>Alarm</b>	Error code. 0 = no errors. See Section 8.1 for error descriptions.
<b>Type</b>	E-BAM machine type: 0 = PM2.5, 1 = PM10.

## 9.6 Advanced Communications – Escape Commands

The communications “escape” command set shown in the table below is not typically used except for advanced data transfer or custom data retrieval software applications. Each command and response string must begin with an Escape character (27, 0x1B) and end with a carriage return (13, 0x0D) and a line feed character (10, 0x0A). An ASCII check sum follows each response (X9999). The hardware protocol is RS-232, 8 data bits, no parity, 1 stop bit.

The E-BAM supports five data files: The EEPROM file (**E**), the Channel Descriptor file (**1**), the AutoMet data log file (**2**), the Error log file (**3**), and the One-Minute diagnostic data log file (**4**). The lowercase **x** in the following commands specifies one of these five files. File modes can be linear (**L**) or circular (**C**). All files are record based.

Function	Command	Response
Read Model and Version	RV	RV E-BAM V1.23
Read File Info (FCB)	RFI	RFI Then print the FCB.
Read record index.	RFx R	RFx R n L RFx R n C
Read data file starting with absolute record index or the last (-n) records from the current record index.	RFx D n RFx D -n	RFx D n Then XMODEM file transfer
Print File Report starting with absolute record index or the last (-n) records from the current record index.	PFx n PFx -n	PFx n Then print the report.
Stop printing report.	PFS	PFS
Clear File Data (x: 2, 3, 4)	WFx C	WFx C
Read Date (mm-dd-yy)	RD	RD 05-10-01
Write Date (mm-dd-yy)	WD 05-10-01	WD 05-10-01
Read Time (hh:mm:ss)	RT	RT 09:08:02
Write Time (hh:mm:ss)	WT 09:08:02	WT 09:08:02

## 9.7 Modem Options for Remote Data Retrieval

The Met One Instrument EX-996 modem is recommended for use with the E-BAM, as it is designed to reliably communicate when other modems may not. Other brands of modems must be set in “dumb” or pass-through mode with no handshaking. If you are using one of the Met One Instruments data acquisition programs such as Air Plus, or MicroMet Plus, you need only enter the telephone number of the site in the system setup menu of the program. Multiple telephone numbers can be entered for connection to multiple remote sites.

If you are communicating with a terminal program such as HyperTerminal<sup>®</sup> you will need to define the serial port configuration in the setup of the terminal program. Set the baud rate to 9600, with 8 data bits, no parity, and 1 stop bit. Use the terminal program’s internal dialing command sequence to dial up the E-BAM. Verify the connection to the unit by pressing the <Enter> key until the command prompt asterisk (\*) appears. If not, verify the cabling and communications settings. Once connected, the access to the E-BAM is the same command driven interface as used for the direct PC connection. Cell phone, radio, and TCP/IP addressable modems are also available for the E-BAM. Because these technologies are always changing, they are handled on a semi-custom basis. Contact Met One for details.

## 9.8 Flash Firmware Upgrades



The E-BAM has the capability for flash firmware upgrades. This allows the field operator to reprogram or update the E-BAM flash EEPROM through the serial port using the Firmware Update Utility program. A Met One technician may supply the firmware update files on a CD or by e-mail if a bug fix is released or if additional features are added to the firmware program that controls the E-BAM operation. The following tasks must be performed whenever the E-BAM firmware is upgraded:

1. **Download and save the data log and error log from the E-BAM before proceeding. These will be cleared from memory during the upgrade process!**
2. Firmware Update Utility is a PC-based utility program which used to update firmware in Met One products equipped with FLASH memory technology. You will need a PC or laptop with an available RS-232 COMM port. Install the Firmware Update Utility program onto the computer by following the prompts after the CD is inserted.
3. Connect the E-BAM serial port to the computer COMM port (usually COMM 1) with the serial cable that came with the E-BAM.
4. Make sure that the computer and the E-BAM are both set to the 9600 baud rate.
5. **Take great effort to ensure that the power source to the E-BAM and the computer will not be interrupted during the update process! A power interruption may cause the E-BAM firmware to become inoperative! If this happens the unit will have to be returned to the factory.** Be especially careful with laptops and USB serial converters to make sure the serial connection does not come loose for the same reason.
6. Run the Firmware Update Utility. From the computer "Start" menu, go to: Programs/Met One/E-BAM/E-BAM Master Program Installer.
7. The program will prompt you for the COMM port number. Enter the number (usually 1) and press ENTER to begin the update.
8. A "**Done!**" message will be displayed at the end of the update process. Execution time is approximately five to fifteen minutes.
9. The E-BAM can now be operated with the new firmware.





## 10 ACCESSORIES and PARTS

### 10.1 Consumables, Replacement Parts, and Accessories

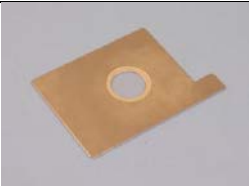

The following parts are available from Met One for maintenance, replacement, service, and upgrades. If unsure about a part you need, please contact the Service department. Some of these parts require technical skills or special considerations before use or installation.

Description	Part Number	Graphic
<b>Consumables</b>		
Filter Tape Roll, Glass Fiber, 30mm x 21m	<b>460130</b>	
Filter Tape Core Tube, Gray Plastic	<b>8150</b>	
Cotton-Tipped Applicators, nozzle cleaning, 100 pack Solon #362	<b>995217</b>	







#### Tools

Span Membrane Assembly, 0.800 mg/cm <sup>2</sup> Replacement part	<b>9325</b>	
Membrane Assembly, Mid-Range, 0.500 mg/cm <sup>2</sup>	<b>EX-301</b>	
Zero Membrane Shim, Nozzle Shipping Shim	<b>9166</b>	
Flow Inlet Adapter Kit (Leak Test Valve)	<b>BX-305</b>	
Zero Filter Calibration Kit, with valve Same as BX-305 but with 0.2 micron filter	<b>BX-302</b>	
Volumetric Flow Calibration Kit (BGI deltaCal™) Flow, Temp, and Pressure Reference Standards Met One recommended flow audit meter	<b>BX-307</b>	



## Flow System Components

E-BAM Internal DC Pump Replacement	<b>9778</b>	
Pump Cover, Sheet Metal	<b>9233</b>	
Pump Purge Tank Filter, 2 per unit	<b>580255</b>	
Flow Sensor, Mass, 0-20 LPM, Internal Assembly	<b>80425</b>	
Filter RH Sensor, Replacement Only	<b>8624</b>	
Filter Temperature Sensor, Replacement Only	<b>8131</b>	
Flow Sensor Debris Filter, Sintered Bronze Element	<b>580299</b>	
O-Ring, Nozzle, 1 required	<b>720066</b>	
O-Ring, Inlet Tube Receiver, 2 required	<b>720069</b>	



## Inlet Components

PM10 Inlet Head, EPA Specified	<b>BX-802</b>	
TSP Sampling Inlet Cap, Harsh Environment with insect screen and rain cap	<b>BX-803</b>	
PM2.5 Sharp Cut Cyclone	<b>BX-807</b>	
PM2.5 WINS Impactor	<b>BX-804</b>	
Inlet Tube Coupler Assembly, with o-rings Connects two inlet tubes together Inlet tube sold separately	<b>BX-821</b>	
Inlet Tube Extension Kit, 4 foot, with coupler and tube	<b>BX-822</b>	
Inlet Tube Extension Kit, 8 foot, with coupler and tube	<b>BX-823</b>	
Standard Inlet Tube, E-BAM, Aluminum, 9 inch	<b>9187</b>	
Inlet Tube, Custom Length Dash number is length in feet, 8' max per tube	<b>8112-X</b>	











Cross-arm Clamp, $\frac{3}{4}$ " x $\frac{3}{4}$ ", Aluminum Mounts cross-arms to the E-BAM tripod	<b>1552</b>	
Inlet Tube Seal, Black Plastic, Weatherproof	<b>480509</b>	
O-Ring Kit, for BX-807 Cyclone, set of 6	<b>720097</b>	
O-Ring Kit, for BX-802 PM10 Head, set of 3	<b>8965</b>	

### Meteorological Sensors

Wind Speed and Wind Direction Combination Sensor For use with E-BAM and E-SAMPLER.	<b>EX-034</b>	
9250 Ambient Temperature Sensor Standard E-BAM Accessory	<b>9250</b>	
Ambient Relative Humidity Sensor	<b>EX-593</b>	

### Miscellaneous Accessories

Display, Vacuum Fluorescent, 4x20 Character	<b>8966</b>	
Gear Motor Assembly Used for nozzle and tape reel	<b>8968</b>	
Wall Mount Bracket for E-BAM. Mounts the E-BAM enclosure to a mast, post, wall, or other vertical surface.	<b>CALL</b>	
Power Supply, E-BAM, 120/220V AC input, 12V DC output, Weatherproof	<b>EX-121</b>	

Tripod Assembly, E-BAM/E-SAMPLER	<b>EX-905</b>	
Tape Spool Cover, Replacement, 2 per unit	<b>9185</b>	
E-BAM Phone Line Modem Kit	<b>EX-996</b>	
E-BAM Cell Modem Kit	<b>EX-911</b>	
Power Cable, E-BAM to Battery	<b>9638</b>	
Power Cable, E-BAM to Battery, with relay output wires	<b>9638-1</b>	
Serial Cable, E-BAM	<b>9321</b>	
Serial Cable, E-BAM, with analog output wires	<b>9321-1</b>	
Belkin F5U109 USB-to-RS-232 Adapter	<b>550067</b>	

## 11 THEORY OF OPERATION and MATHEMATICAL ANALYSIS

When the high-energy electrons emanating from the radioactive decay of  $^{14}\text{C}$  (carbon-14) interact with nearby matter they lose their energy and, in some cases, are absorbed by the matter. These high-energy electrons emitted through radioactive decay are known as beta rays and the process is known as beta-ray attenuation. When matter is placed between the radioactive  $^{14}\text{C}$  source and a device designed to detect beta rays, the beta rays are absorbed and/or their energy diminished. This results in a reduction in the number of beta particles detected. The magnitude of the reduction in detected beta particles is a function of the mass of the absorbing matter between the  $^{14}\text{C}$  beta source and the detector.

The number of beta particles passing through absorbing matter, such as dust deposited on a filter tape, decrease nearly exponentially with the mass through which they must pass. Equation 1 shows this relationship.

**Equation 1**

$$I = I_0 e^{-\mu x}$$

In Equation 1,  $I$  is the measured beta ray intensity (counts per unit time), of the attenuated beta ray (dust laden filter tape),  $I_0$  is the measured beta ray intensity of the un-attenuated beta ray (clean filter tape),  $\mu$  is the absorption cross section of the material absorbing the beta rays ( $\text{cm}^2/\text{g}$ ), and  $x$  is the mass density of the absorbing matter ( $\text{g}/\text{cm}^2$ ).

Equation 1 very closely resembles the Lambert-Beers Law, which is used in spectrometric analysis. Just as the Lambert-Beers Law is an idealization of what is actually observed, Equation 1 is also an idealized simplification of the true processes occurring meant to simplify the corresponding mathematics. However, experimental measurement shows that in properly designed monitors, such as the BAM-1020, the use of this equation introduces no substantial error.

Equation 1 may be rearranged to solve for  $x$ , the mass density of the absorbing matter. This is shown in Equation 2.

**Equation 2**

$$-\frac{1}{\mu} \ln \left[ \frac{I}{I_0} \right] = \frac{1}{\mu} \ln \left[ \frac{I_0}{I} \right] = x$$

In practice, the absorption cross section is experimentally determined during the calibration process. Once  $I$  and  $I_0$  are experimentally measured, it is a simple matter to calculate  $x$ , the predicted mass density.

In practice, ambient air is sampled at a constant flow rate ( $Q$ ) for a specified time  $\Delta t$ . This sampled air is passed through a filter of surface area  $A$ . Once  $x$ , the mass density of collected particles, has been determined, it is possible to calculate the ambient concentration of particulate matter ( $\mu\text{g}/\text{m}^3$ ) with Equation 3.

### Equation 3

$$c \left( \frac{\mu\text{g}}{\text{m}^3} \right) = \frac{10^6 A(\text{cm}^2)}{Q \left( \frac{\text{liter}}{\text{min}} \right) \Delta t(\text{min}) \mu \left( \frac{\text{cm}^2}{\text{g}} \right)}$$

In Equation 3,  $c$  is the ambient particulate concentration ( $\mu\text{g}/\text{m}^3$ ),  $A$  is the cross sectional area on the tape over which dust is being deposited ( $\text{cm}^2$ ),  $Q$  is the rate at which particulate matter is being collected on the filter tape (liters/minute), and  $\Delta t$  is the sampling time (minutes). Combining these equations yields to the final expression for the ambient particulate concentration in terms of measured quantities. This is shown in Equation 4.

### Equation 4

$$c \left( \frac{\mu\text{g}}{\text{m}^3} \right) = \frac{10^6 A(\text{cm}^2)}{Q \left( \frac{\text{liter}}{\text{min}} \right) \Delta t(\text{min}) \mu \left( \frac{\text{cm}^2}{\text{g}} \right)} \ln \left( \frac{I_0}{I} \right)$$

The key to the success of the beta attenuation monitor is due in part to the fact that  $\mu$ , the absorption cross-section, is almost insensitive to the nature of the matter being measured. This makes the BAM-1020 very insensitive to the chemical composition of the material being collected.

It is instructive to perform a conventional propagation of errors analysis on Equation 4. Doing so, one can develop an equation for the relative measurement error ( $\sigma_c/c$ ) as a function of the uncertainty in each of the parameters comprising Equation 4. This leads to Equation 5.

### Equation 5

$$\frac{\sigma_c}{c} = \sqrt{\frac{\sigma_A^2}{A^2} + \frac{\sigma_Q^2}{Q^2} + \frac{\sigma_t^2}{t^2} + \frac{\sigma_\mu^2}{\mu^2} + \frac{\sigma_I^2}{I^2 \ln \left[ \frac{I}{I_0} \right]^2} + \frac{\sigma_{I_0}^2}{I_0^2 \ln \left[ \frac{I}{I_0} \right]^2}}$$

Inspection of Equation 5 reveals several things. The relative uncertainty of the measurement ( $\sigma_c/c$ ) is decreased (improved) by increasing the cross sectional area of the filter tape ( $A$ ), the flow rate ( $Q$ ), the sampling time ( $t$ ), the absorption cross-section ( $\mu$ ),  $I$  and  $I_0$ .

In practice, the uncertainty associated with the filter area ( $\sigma_A/A$ ), may be minimized by ensuring that the tape is in exactly the same position during the  $I_0$  measurement as in the  $I$  measurement phase. Careful design of the shuttle and tape control mechanisms inside of the BAM-1020 results in minimal error here.

The uncertainty in the flow rate ( $\sigma_Q/Q$ ) may be minimized by properly controlling the flow of the instrument. For BAM-1020 units with a manual flow valve, this value is on the order of  $\pm 3\%$ . For BAM-1020 units equipped with the mass flow controller device, ( $\sigma_Q/Q$ ) decreases to  $\pm 1\%$ .

The relative error due to the uncertainty in the absorption cross section ( $\sigma_\mu/\mu$ ), is due to its slight variation as a function of the chemical composition of the matter being monitored. Generally, this relative error is on the order of  $\pm 2-3\%$ , with judicious selection of the calibrated value of  $\mu$ .

The uncertainty associated with the measurement of I and I<sub>0</sub> has to do with the physical nature of the process leading to the emission of beta particles from the decay of <sup>14</sup>C. This process follows Poisson statistics. Poisson statistics show the uncertainty in the measurement of I (σ<sub>I</sub>/I) and I<sub>0</sub> (σ<sub>I0</sub>/I<sub>0</sub>) are minimized by increasing the sampling time. Mathematical analysis shows that doubling the sampling time and hence the measured intensity of I or I<sub>0</sub> will reduce the uncertainty of the measurement by a factor of 1.41 (square root of 2).

### 11.1 Converting Data Between EPA Standard and Actual Conditions

As described in this manual, the BAM-1020 can obtain concentration data using either actual or standard values for ambient temperature and pressure. In some cases, it is necessary to convert past concentration data collected in standard conditions to actual conditions, or the other way around. Note: temperature is in degrees Kelvin (C+273) and pressure is in mmHg.

#### Equation 6

$$C_{std} = C_{amb} * (P_{std} / P_{amb}) * (T_{amb} / T_{std})$$

Equation 6 can be used to calculate the standard concentration (C<sub>std</sub>) from the ambient concentration (C<sub>amb</sub>) data using ambient barometric pressure and temperature data (P<sub>amb</sub> and T<sub>amb</sub>) from the same time period in which the ambient concentration was recorded. P<sub>std</sub> and T<sub>std</sub> are the values of standard barometric pressure and standard ambient temperature. These values are usually the EPA mandated 760 mmHg and 298 degrees Kelvin (25 C). **Note:** Some other countries use different values for standard temperature and pressure.

#### Equation 7

$$C_{amb} = C_{std} * (P_{amb} / P_{std}) * (T_{std} / T_{amb})$$

Equation 7 can be used to calculate the ambient concentration (C<sub>amb</sub>) from the standard concentration (C<sub>std</sub>) data using the ambient temperature and pressure. It is necessary to have access to valid data for the ambient temperature and pressure for the desired sample hour in order to be able to make the calculations.

**Example:** You have a data value of 27µg from a BAM which was configured to report data in EPA Standard conditions (298K and 760 mmHg), but you need to know what the concentration would have been in actual conditions. The actual average temperature for the hour in question was 303K and the average pressure was 720mmHg.

$$\begin{aligned}
 C_{amb} &= C_{std} * (P_{amb} / P_{std}) * (T_{std} / T_{amb}) \\
 C_{amb} &= 27 * (720/760) * (298/303) \\
 C_{amb} &= 27 * 0.9474 * 0.9835 \\
 C_{amb} &= 25.1 \mu\text{g}
 \end{aligned}$$

## 12 SPECIAL E-BAM CONFIGURATIONS

Because of its modular nature, the E-BAM is often supplied in custom configurations in order to meet specific monitoring needs.

### 12.1 External Pump Box Configurations for the E-BAM

The E-BAM can be factory configured to use an external AC powered pump box module which replaces the internal pump that is included with standard E-BAM units. The E-BAM used for this configuration is a special model number E-BAM/9770, and the external pump box assembly has a model number EX-125 (115V) or EX-126 (220V). This gives the E-BAM longer pump life at the expense of portability. The general functionality of this version is the same as the regular E-BAM.

The external pump box sits on the ground under the E-BAM tripod. The E-BAM has the same four standard electrical connectors on the bottom, with the addition of a pump box control connector. This connection provides signals to the pump box so that the E-BAM can turn the pump on and off and drive the flow controller motor. Plug the Pump Box Control cable into the extra connector on the E-BAM. The pump box also has a built in power supply to power the E-BAM. Plug the power cable from the pump box into the normal E-BAM power input. Plug the pump box power cord into an AC outlet to power up the E-BAM and to supply power to the pump. A length of 10mm OD vacuum tubing must also be connected between the E-BAM and the pump box.

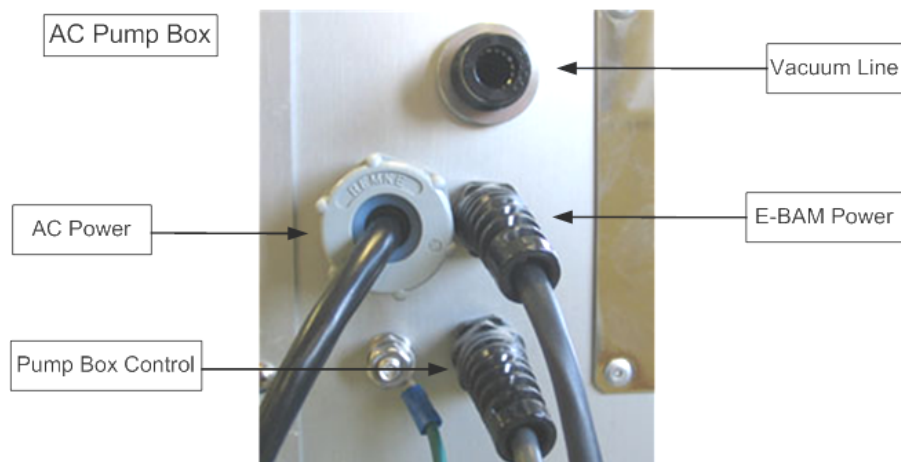
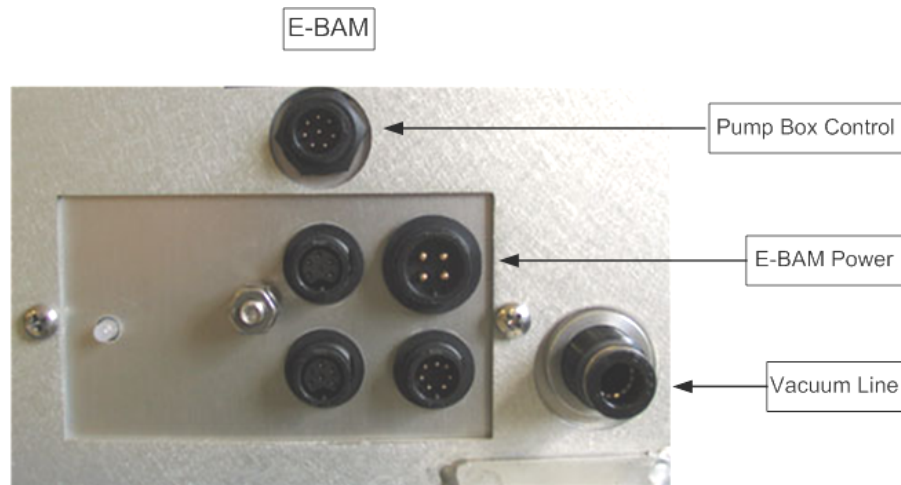

Another variation of the external pump box option is the E-BAM-5LPM model. This is a special E-BAM that runs at 5.0 liters per minute with a special PM10 inlet configuration. The external pump box used for this option contains a special pump and flow controller for the lower flow rate, and the E-BAM has special firmware to allow flow regulation and calibration at 5 LPM. This is for extreme particulate conditions only, where the ambient concentration can exceed several milligrams in only a few minutes. The detection limit of the E-BAM-5LPM is not suitable for normal ambient monitoring. This model is sold on a semi-custom basis only.

## **12.2 AIRSIS Satellite Uplink Option**

The E-BAM can be equipped with an optional Iridium satellite communications module which can download digital data from the E-BAM serial port and upload it through a satellite system. The module is designed by AIRSIS specifically for use with the E-BAM, and mounts directly onto the tripod. The system is widely used for remote deployments. Contact Met One for details about this configuration.

# 13 E-BAM AUDIT SHEET

Model:  Serial Number:

Audit Date:  Audited By: \_\_\_\_\_

Flow Audits			
Flow Reference Standard Used:	Model:	Serial No:	Calibration Date:
Temperature Standard Used:	Model:	Serial No:	Calibration Date:
Barometric Pressure Standard Used:	Model:	Serial No:	Calibration Date:

Leak Check Value:	as found:	<input type="text" value="lpm"/>	as left:	<input type="text" value="lpm"/>
Ambient Temperature:	as found:	<input type="text" value="C"/>	as left:	<input type="text" value="C"/>
Barometric Pressure:	as found:	<input type="text" value="mmHg"/>	as left:	<input type="text" value="mmHg"/>
16.7 lpm Flow Rate (Actual):	as found:	<input type="text" value="lpm"/>	as left:	<input type="text" value="lpm"/>
16.7 lpm Flow Rate (Standard):	as found:	<input type="text" value="slpm"/>	as left:	<input type="text" value="slpm"/>

## Mechanical Audits

Sample nozzle clean:	as found	<input type="checkbox"/>	as left	<input type="checkbox"/>	PM10 particle trap clean:	as found	<input type="checkbox"/>	as left	<input type="checkbox"/>
Tape support vane clean:	as found	<input type="checkbox"/>	as left	<input type="checkbox"/>	PM10 drip jar empty:	as found	<input type="checkbox"/>	as left	<input type="checkbox"/>
Tape spool covers tight:	as found	<input type="checkbox"/>	as left	<input type="checkbox"/>	PM10 bug screen clear:	as found	<input type="checkbox"/>	as left	<input type="checkbox"/>
	as found	<input type="checkbox"/>	as left	<input type="checkbox"/>	PM2.5 particle trap clean:	as found	<input type="checkbox"/>	as left	<input type="checkbox"/>

Analog Voltage Output Audit	N/A
DAC Test Screen	E-BAM Volt Output
0.010 Volts	Volts
0.500 Volts	Volts
0.990 Volts	Volts

Manual Span Membrane Test
Expected Span Mass (mg/cm2):
Measured Span Mass (mg/cm2):
Difference (mg/cm2):
% Difference:

Pump Test	
Flow Setpoint	E-BAM Flow
14.0 lpm	
16.7 lpm	
17.5 lpm	

Setup and Calibration Values								
Parameter	Expected	Found	Parameter	Expected	Found	Parameter	Expected	Found
Clock			Analog Mode			Flow Type		
Location			Baud Rate			Restart Voltage		
Tape Advance			RH Setpoint			Std Cond Temp		
Realtime Avg			Delta-T Setpoint					
Machine Type			RH Control					
Analog FS			Flow Setpoint					

## Last 6 Errors in E-BAM Error Log

Error	Date	Time	Error	Date	Time
1			4		
2			5		
3			6		

Audit Notes: \_\_\_\_\_  
 \_\_\_\_\_  
 \_\_\_\_\_





**ATTACHMENT 3  
E-BAM AUDIT CHECKLIST**

# 13 E-BAM AUDIT SHEET

Model:  Serial Number:

Audit Date:  Audited By: \_\_\_\_\_

Flow Audits			
Flow Reference Standard Used:	Model:	Serial No:	Calibration Date:
Temperature Standard Used:	Model:	Serial No:	Calibration Date:
Barometric Pressure Standard Used:	Model:	Serial No:	Calibration Date:

Leak Check Value:	as found:	<input type="text" value="lpm"/>	as left:	<input type="text" value="lpm"/>
Ambient Temperature:	as found:	<input type="text" value="C"/>	as left:	<input type="text" value="C"/>
Barometric Pressure:	as found:	<input type="text" value="mmHg"/>	as left:	<input type="text" value="mmHg"/>
16.7 lpm Flow Rate (Actual):	as found:	<input type="text" value="lpm"/>	as left:	<input type="text" value="lpm"/>
16.7 lpm Flow Rate (Standard):	as found:	<input type="text" value="slpm"/>	as left:	<input type="text" value="slpm"/>

## Mechanical Audits

Sample nozzle clean:	as found	<input type="checkbox"/>	as left	<input type="checkbox"/>	PM10 particle trap clean:	as found	<input type="checkbox"/>	as left	<input type="checkbox"/>
Tape support vane clean:	as found	<input type="checkbox"/>	as left	<input type="checkbox"/>	PM10 drip jar empty:	as found	<input type="checkbox"/>	as left	<input type="checkbox"/>
Tape spool covers tight:	as found	<input type="checkbox"/>	as left	<input type="checkbox"/>	PM10 bug screen clear:	as found	<input type="checkbox"/>	as left	<input type="checkbox"/>
	as found	<input type="checkbox"/>	as left	<input type="checkbox"/>	PM2.5 particle trap clean:	as found	<input type="checkbox"/>	as left	<input type="checkbox"/>

Analog Voltage Output Audit	N/A
DAC Test Screen	E-BAM Volt Output
0.010 Volts	Volts
0.500 Volts	Volts
0.990 Volts	Volts

Manual Span Membrane Test
Expected Span Mass (mg/cm2):
Measured Span Mass (mg/cm2):
Difference (mg/cm2):
% Difference:

Pump Test	
Flow Setpoint	E-BAM Flow
14.0 lpm	
16.7 lpm	
17.5 lpm	

Setup and Calibration Values								
Parameter	Expected	Found	Parameter	Expected	Found	Parameter	Expected	Found
Clock			Analog Mode			Flow Type		
Location			Baud Rate			Restart Voltage		
Tape Advance			RH Setpoint			Std Cond Temp		
Realtime Avg			Delta-T Setpoint					
Machine Type			RH Control					
Analog FS			Flow Setpoint					

## Last 6 Errors in E-BAM Error Log

Error	Date	Time	Error	Date	Time
1			4		
2			5		
3			6		

Audit Notes: \_\_\_\_\_  
 \_\_\_\_\_  
 \_\_\_\_\_



**ATTACHMENT 4  
ADDITIONAL BACKGROUND SUMMARY OF THE FORMER FORT ORD PRESCRIBED  
BURN AIR SAMPLING AND ANALYSIS PROGRAM**

## **Additional Background Summary of the former Fort Ord Prescribed Burn Air Sampling and Analysis Program**

The Army is conducting prescribed burns within the Impact Area Munitions Response Area (MRA) as part of the remedy for the cleanup of munitions and explosives of concern. The remedy was selected in accordance with the Comprehensive Environmental Response, Compensation, and Liability Act (CERCLA or Superfund) and documented in *Record of Decision, Impact Area Munitions Response Area Track 3 Munitions Response Site, Former Fort Ord, California* signed in 2008 (Track 3 ROD) (Administrative Record [AR] number: OE-0647).

The description of prescribed burning in the Track 3 ROD included air monitoring as a component. However, no federal or state regulatory requirement existed for conducting air monitoring during any prescribed burn. Therefore, the Track 3 ROD included a general description that indicated a monitoring program that would be implemented at the former Fort Ord. In coordination with various agencies, the Army has continued its particulate monitoring program built on the knowledge developed during previous air monitoring events (2003 and 2006 prescribed burns) conducted under the *Record of Decision, Interim Action For Ordnance and Explosives at Ranges 43-48, Range 30A, and Site OE-16* (Interim Action ROD) (AR number: OE-0414). In 2003, air emissions data were collected during the active ignition and smolder phases of the prescribed burn at Ranges 43-48, as well as before and after the prescribed burn to provide baseline data. Sampling locations consisted of two burn area stations, three on-base stations, nine public stations, and one mobile station. The results indicated:

- Munitions-related chemicals were not detected in any of the samples, even though: 1) the total area burned (1,500 acres) was three times the intended acreage, 2) two of the stations were within the burn area, and 3) the burn area was considered to have the highest concentration of explosive munitions.
- Elevated concentrations of a few particulate metals were observed at one station, but all are common to native soil and plant tissue and their presence would be expected in smoke from vegetation burning.
- Dioxins/furans were either not detected, or were present at concentrations below air screening levels, in all samples.
- Other than at two sampling locations within the burn area and one other sample, acetaldehyde and formaldehyde were not detected above the screening level.
- Except for the burn area during ignition and smolder days, and an anomalous occurrence at the Monterey Aquarium on the smolder day, acrolein concentrations appeared similar to ambient concentrations shown in various ambient air studies. In addition, acrolein concentrations were also recorded above the regulatory screening level at five stations during baseline sampling.

- Particulate matter less than 10 microns (PM<sub>10</sub>) concentrations (the best overall measure of smoke impacts) on the active ignition day were significantly above the screening level (the 24-hour based California Ambient Air Quality Standard [CAAQS]), at nearly every monitoring site. Elevated PM<sub>10</sub> concentrations on the second (smolder) day were even more widespread, with every site essentially at or above the screening level. Because of the possibility of short-term smoke impacts and because PM<sub>10</sub> was determined to be the best overall indicator of smoke impacts, it was recommended that monitoring for PM<sub>10</sub> be retained in future prescribed burn air monitoring programs.

The monitoring program provides data to support the program objectives: 1) to assess the adequacy of the burn prescription relative to smoke dispersion and downwind impacts and 2) monitor and evaluate whether the prescribed burns at the former Fort Ord result in downwind ambient concentrations of particulate matter that exceed the applicable health-based screening levels. The 24-hour National Ambient Air Quality Standard (NAAQS) for particulate matter less than 2.5 microns (PM<sub>2.5</sub>) of 35µg/m<sup>3</sup> is currently used as the screening level.

The history and rationale for initially evaluating a wide range of potential pollutants of interest, and arriving at a monitoring program that utilized 24-hour based PM<sub>10</sub> can be found in several documents. The *Final Track 3 Impact Area Munitions Response Area, Munitions Response Remedial Investigation/Feasibility Study*, (Track 3 RI/FS) (Administrative Record: OE-0596R) provides information and references on prescribed burning as part of the Track 3 remedy.

### Monitoring network

The current program to utilize a network of six (previously five) pre-selected (or fixed) stations, supplemented by one (previously two) additional station that is deployed on the day before the planned burn, has been implemented successfully and covers a wide area surrounding planned burn areas. To address potential gaps in the monitoring network, on the day before the planned prescribed burn, one of the five candidate locations is selected for use based on the meteorological conditions anticipated for the burn day (next day). One of the previous candidate locations was converted to pre-selected in 2015 based on historical knowledge of meteorological patterns during prescriptive conditions along with a review of historical air monitoring results. The rationale for this approach, including the data quality objectives (DQO) process, is described in detail in the Air Sampling and Analysis Plan included in the *Final Work Plan, MRS-BLM Burn Units 01-05 Munitions and Explosives of Concern Removal, Former Fort Ord, California* developed in 2008 (AR number: OE-0626L). This plan was developed in full coordination with the regulatory agencies and the public. The air sampling and analysis plans for 2008, 2009 and 2010 prescribed burns were issued as amendments to the initial plan, because the burn areas were of similar vegetation types and utilized similar burn prescriptions. The same rationale for the locations of air monitoring stations and their deployment continues to be applicable after the program transitioned in 2011 to monitor for PM<sub>2.5</sub>.

### Analyte and screening level

The Army has obtained PM<sub>10</sub> monitoring data during many burns which resulted in a conclusion that, while smoke can be experienced for short periods at any given location during the prescribed burns, because of the typical shifts in surface wind directions, PM<sub>10</sub> concentrations that exceed the screening level for a 24-hour period are not expected. Even though a PM<sub>10</sub>-based program would continue to provide data that can support the program objectives (to assess the adequacy of the burn prescription relative to smoke dispersion and downwind impacts and evaluate whether prescribed burns result in downwind ambient concentrations of PM<sub>10</sub> that exceed the applicable health screening levels), in 2011 the Army decided to implement a PM<sub>2.5</sub>-based air monitoring program considering the advice of Monterey Bay Air Resources District (MBARD) (formerly Monterey Bay Unified Air Pollution Control District [MBUAPCD]), comments from the regulatory agencies and the public, and the opportunity to obtain more information from the air monitoring program that could possibly lead to further improvements to the prescribed burn program at the former Fort Ord.

Initially, a regulatory health-based screening level was available to compare the PM<sub>10</sub> results (the 24 hour based CAAQS of 50 µg/m<sup>3</sup>). It should be noted that an ambient air quality standard is not directly applicable to emissions from a prescribed burn event or any other specific source of air emissions. The PM<sub>10</sub> program continued, allowing for ready comparison of data with historical air monitoring results.

The State of California has not set a 24-hour based ambient standard for PM<sub>2.5</sub>. Effective December 2006, the NAAQS for PM<sub>2.5</sub> was lowered from 65 µg/m<sup>3</sup> to 35 µg/m<sup>3</sup>. This standard is qualified with the specific “form” that is, to attain this standard, the 3-year average of the 98th percentile of 24-hour concentrations at each population-oriented monitor within an area must not exceed 35 µg/m<sup>3</sup>. This means the ambient standard is not violated unless a number of exceedances occur in a specific monitoring station that is part of the network of approved monitoring sites over multiple years. Therefore, the use of the current 24-hour based NAAQS for PM<sub>2.5</sub> as a screening level is considered very conservative. Again, an ambient air quality standard is not directly applicable to emissions from a prescribed burn event. However, MBARD considers PM<sub>2.5</sub> as the more appropriate indicator of prescribed burn smoke, since the majority of particulate matter in smoke from vegetation burns typically are in the smaller size range. Also, smaller size range of particulate matter can more easily be trapped deeper inside the lungs, so a higher health-based concern can be associated with PM<sub>2.5</sub>. For these reasons, MBARD considers the 24-hour based NAAQS of 35 µg/m<sup>3</sup> for PM<sub>2.5</sub> as the appropriate criteria to use as the health-based screening level for the air monitoring program.

### Sampling method

To obtain data that can be compared to the 24-hour based screening level, until 2013 the Army’s air monitoring program utilized a volumetric sampling method. Particulate matter in the air sample is collected on a filter, which is later weighted in a laboratory. The sample collection and analysis procedures met the requirements established by EPA for such measurements. Over time, the volumetric samplers



required increasing levels of maintenance, and in 2015, the Army decided to replace the air monitoring equipment. Several units were evaluated, and the Environmental Proof Instrument Beta Attenuation Monitor (E-BAM) was selected as a sampler that can provide the desired data in a manner that is easy to deploy, requires less maintenance, can provide near-real time data, and is cost effective if used for multiple years. As described in *Final Prescribed Burn Air Sampling and Analysis Plan, MRS-BLM Burn Units 11 and 12, Former Fort Ord, California* (AR number: OE-0851C), since 2015 the air monitoring program utilizes the E-BAM units that will be placed in the established network of sampling locations, to provide data that can be compared to the 24-hour based screening level for PM<sub>2.5</sub>.

Since 2010, MBARD has implemented near-real-time monitoring of PM<sub>2.5</sub> using E-BAM units at several locations in the community to improve public communication about smoke levels during prescribed burns and associated public health-related information. MBUAPCD has noted that its data is not intended to be used for the purpose of complying with ambient air quality standards.

**ATTACHMENT 5  
RESPONSE TO COMMENTS**



## RESPONSES TO COMMENTS

Document: Draft Final, Quality Assurance Project Plan, Former Fort Ord, California, Volume II, Appendix C, Prescribed Burn Air Monitoring

Commenting Organization: United States Environmental Protection Agency (EPA)

Name: Maeve Clancy

Date of Comments: November 16, 2016

### **Specific Comment 1:**

EPA has reviewed the *Draft Final Quality Assurance Project Plan, Former Fort Ord, California, Volume II, Appendix C, Prescribed Burn Air Monitoring* dated October 14, 2016, and the associated response to comments (RTC). We are satisfied with the draft final QAPP and RTC for all comments except general comment #2: "The QAPP does not address sharing air quality data collected during the prescribed burns externally. In Section 2.2 (Worksheet #11) Step 2, please add a study goal related to providing air quality data to stakeholders (i.e. Monterey Bay Air Quality Resources District, local jurisdictions, and community groups) and the general public in a timely manner. Update all steps in Worksheet #11, and the rest of the QAPP, as appropriate."

The RTC for comment #2 says the following: "Starting in 2016 the near-real-time raw data file from the Environmental Proof Instrument Beta Attenuation Monitor (E-BAM) units will be provided near-real time to Monterey Bay Air Resource District (MBARD) who will post the raw data on the MBARD website for public information. A row will be added for raw data in the QAPP Worksheet #29." We do not believe that updating worksheet #29 adequately addresses the comment, and would like to see changes made to worksheet #11.

### **Response to Specific Comment 1:**

The Army acknowledges EPA's interest in sharing available data with the public in a timely manner. The Army had worked with MBARD to make the prescribed burn air monitoring data available to the public in near-real time starting in 2016. The release of data to MBARD was added to the data management section of the QAPP (Worksheet #29).

As described in the document and previous responses to EPA comments, the Army conducts prescribed burn air monitoring designed to support the following program objectives: 1) to assess the adequacy of the burn prescription relative to smoke dispersion and downwind impacts and 2) to monitor and evaluate whether the prescribed burns at the former Fort Ord result in downwind ambient concentrations of PM<sub>2.5</sub> that exceed the applicable health-based screening levels. The 24-hour federal standard for PM<sub>2.5</sub> of 35µg/m<sup>3</sup> is used as the screening level.

## RESPONSES TO COMMENTS

The E-BAM units are capable of generating one-hour average concentrations. Based on this data MBARD will post three-hour average concentrations on its website. Real-time release of the data during the monitoring period does not relate to the study objectives to assess the burn prescription or to evaluate the results relative to the screening level. Therefore, the release of data to MBARD was added to the data management section of the QAPP (Worksheet #29). The Army will also describe in future site-specific prescribed burn air monitoring plans the manner in which the data would be made available to the public.



## RESPONSES TO COMMENTS

Document: Draft Final, Quality Assurance Project Plan, Former Fort Ord, California, Volume II, Appendix C, Prescribed Burn Air Monitoring

Commenting Organization: Fort Ord Community Advisory Group (FOCAG)

Name: Mike Weaver

Date of Comments: November 18, 2016

### **Specific Comment 1:**

The document's author is KEMRON. What are KEMRON's qualifications?

### **Response to Specific Comment 1:**

KEMRON is providing environmental remediation and munitions response services at the former Fort Ord under a contract with U.S. Army Corps of Engineers.

### **Specific Comment 2:**

There is no analysis of the exact locations of air monitoring stations and why they are considered appropriate. Since the policy was removed that required the air to be blowing out over the Pacific Ocean on a burn day, the heavy burn smoke is now almost guaranteed to blow south-east, directly towards the populated areas of Corral de Tierra and San Benancio. Once there the smoke surrounds the hillsides and then drops down into the valleys. Later it gets blown north-east towards and into the City of Salinas. From there down the Salinas Valley. Army technicians know this. Does KEMRON? Why isn't this included in the Project Plan?

### **Response to Specific Comment 2:**

The air monitoring network for the Fort Ord prescribed burn monitoring program is designed to include areas surrounding the burn area and are generally placed in areas within or adjacent to populated areas that are likely to experience the presence of smoke. The air monitoring locations adequately represent the areas in their immediate vicinities. This network has been developed in coordination with the regulatory agencies and the public, and has been updated based on comments and recommendations from the regulatory agencies. Results from previous air monitoring events were reviewed during the development of this document.

### **Specific Comment 3:**

A CD disc of information and responses to previous comments was included with this document. 410 pages worth of data, on CD. As reported before, it is hard to read on a computer.

## RESPONSES TO COMMENTS

### **Response to Specific Comment 3:**

No response is necessary.

### **Specific Comment 4:**

Where is the analysis of the cumulative impacts of all the recent smoke from the Soberanes Fire on this same population? Why is a 24-hour Federal standard for PM 2.5 of 35 ug/m<sup>3</sup> used? There are other circumstances such as the weeks-long Soberanes and Chimney fires recently. How about considering putting a Project Plan off until next year?

### **Response to Specific Comment 4:**

Conducting an analysis of smoke from wildfires is not necessary for the development of the monitoring network to be used during the Army's prescribed burns. The suggested delay to finalization of this document is not warranted. The 24-hour National Ambient Air Quality Standard for PM<sub>2.5</sub> of 35 µg/m<sup>3</sup> was determined as appropriate for use as the regulatory health-based screening level for the Army's prescribed burn air monitoring program. The selection of the screening level is described in Attachment 4 of this document. The Army will consider a prescribed burn if all meteorological and fuel moisture requirements are met and adequate fire resources are available.

### **Specific Comment 5:**

We read that MBARD will have a website - data for public information regarding burn smoke. How will this be advertised? How will people know how to access this? Who creates the website with explanations as to how to interpret and understand the data presented? Will monitoring locations be included so the public can know if the data being presented is even applicable to them or not? Will a phone number be provided to call with questions?

### **Response to Specific Comment 5:**

The Army works closely with Monterey Bay Air Resources District (MBARD) to provide prescribed burn information to the community. The MBARD website includes a section dedicated to providing air quality information to the public (<http://mbard.org/air-quality>). The Army's 2016 prescribed burn outreach materials advise readers that additional information is available from the MBARD website. For any questions about the Army's prescribed burns, community members are encouraged to call the Army's information line at 800-852-9699.

### **Specific Comment 6:**

Our concerns remain about the Army burn getting accidentally out of control as they have so many times in the past. We learn that unexploded ordnance can travel approximately 1/3 mile ...

## RESPONSES TO COMMENTS

red hot metal traveling outside the burn onto dry California hillsides. The Army does not carry insurance. They are the government. Does KEMRON carry insurance? What is the insurance risk factor for this Project Plan burn?

### **Response to Specific Comment 6:**

When planning for any prescribed burn a considerable effort is made, focusing on fire containment and minimizing smoke impacts to the community. To maintain the fire within the Fort Ord boundary, a containment line network and contingency plan are put in place for every burn. Combined with other measures, the Army takes extensive precautions to ensure that burns are conducted under appropriate weather conditions and are contained on former Fort Ord. These measures are described in site-specific prescribed burn plans.



## RESPONSES TO COMMENTS

Document: Draft, Quality Assurance Project Plan, Former Fort Ord, California, Volume II, Appendix C, Prescribed Burn Air Monitoring

Commenting Organization: United States Environmental Protection Agency (EPA)

Name: Maeve Clancy

Date of Comments: August 25, 2016

### **General Comment 1:**

QAPP Section 2.2 (Worksheet #11) identifies the first goal of the study as an assessment of the adequacy of the burn prescription relative to smoke dispersion (see Steps 1 and 2), but further information for how the proposed activities will address this study goal is not provided. For example, the information inputs (Step 3) do not define the data that will be used to assess the adequacy of the burn prescription, and decision statements (Step 5) are not provided for how the adequacy will be assessed and what actions will be taken. Further, the collection of data for this study goal is not discussed in Worksheets #14 or #16. Please revise the QAPP to include the assessment of the adequacy of the burn prescription in all steps in Worksheet #11 and the collection of data for this study goal in all applicable worksheets.

### **Response to General Comment 1:**

The Army acknowledges that the first goal of the study in Step 2 of the data quality objectives (DQOs) in Worksheet #11 did not communicate the study goals effectively. The bullet will be revised to: "Is the burn prescription adequate?" Burn prescription is developed for each planned burn, incorporating the current industry best practices for wildland prescribed burns, explosives safety considerations, and information from past burns including air monitoring data. Burn prescription will be described in site-specific prescribed burn plans. An example of a burn prescription is provided in Table 1.

While there is no federal or state regulation that requires the Army or any entity (public or private) to conduct particulate air monitoring during any prescribed burn, the Army conducts the particulate matter less than 2.5 microns (PM<sub>2.5</sub>) monitoring program because the monitoring data supported the program objectives: 1) to assess the adequacy of the burn prescription relative to smoke dispersion and downwind impacts and 2) monitor and evaluate whether the prescribed burns at the former Fort Ord result in downwind ambient concentrations of PM<sub>2.5</sub> that exceed the applicable health-based screening levels. The 24-hour federal standard for PM<sub>2.5</sub> of 35µg/m<sup>3</sup> is used as the screening level.



## RESPONSES TO COMMENTS

### **General Comment 2:**

The QAPP does not address sharing air quality data collected during the prescribed burns externally. In Section 2.2 (Worksheet #11) Step 2, please add a study goal related to providing air quality data to stakeholders (i.e. Monterey Bay Air Quality Resources District, local jurisdictions, and community groups) and the general public in a timely manner. Update all steps in Worksheet #11, and the rest of the QAPP, as appropriate.

### **Response to General Comment 2:**

Starting in 2016 the near-real-time raw data file from the Environmental Proof Instrument Beta Attenuation Monitor (E-BAM) units will be provided near-real-time to Monterey Bay Air Resources District (MBARD) who will post the data on the MBARD website for public information. A row will be added for raw data in the QAPP Worksheet #29.

### **General Comment 3:**

The QAPP does not provide the rationale for the number and locations of the pre-selected fixed locations and the five candidate monitoring locations. For example, it is unclear why these pre-selected locations were determined to provide adequate coverage to assess smoke impacts from the prescribed burns (e.g., wind direction is not discussed). In addition, Worksheet #11 indicates that the sampling network would be selected to cover the likely area of maximum impact, but this area is not discussed in Worksheet #17. Finally, it is unclear why six fixed locations were selected and why only one candidate location will be monitored. Please revise Section 3.0, Sample Design (Worksheet #17) to provide the rationale for why the number and selected monitoring locations was determined to be sufficient to assess the smoke impacts from the prescribed burn.

### **Response to General Comment 3:**

As described in additional background summary in Attachment 4, the current program to utilize a network of six pre-selected (or fixed) stations, supplemented by one additional station that is deployed on the day before the planned burn (previously five pre-selected and two additional), has been implemented successfully. The rationale for this approach is described in *Final Work Plan, MRS-BLM Units 01-05 Munitions and Explosives of Concern Removal, Former Fort Ord, California* developed in 2008. The placement of the sampling network stations for the prescribed burn program provides broad coverage surrounding the burn units, and are generally placed in areas within or adjacent to populated areas that are likely to experience the presence of smoke. As discussed in Worksheet #11, DQO Step 7, the network design considers the possibility that the location of the highest concentration of the PM<sub>2.5</sub> in air may vary during the monitoring event, as meteorological conditions evolve throughout the day. In addition,

## RESPONSES TO COMMENTS

Worksheet #18 describes that, to accommodate potential burn scenarios, the monitoring network locations were chosen to meet the air monitoring unit siting criteria; areas that may experience smoke and visual impacts based on typical, known weather patterns; and locations that ideally have AC power available. One of the five candidate stations will be selected on the day before the planned burn in consultation with the Army, EPA, DTSC and MBARD based on the meteorological conditions anticipated for the burn day (next day). Monitoring locations outside the former Fort Ord boundary require obtaining rights of entry which necessitates identifying and coordinating the monitoring locations (including the five candidate locations) well in advance of a prescribed burn.

### **General Comment 4:**

It is unclear how the one candidate station location to be monitored during the prescribed burn will be selected. The purpose of the candidate station is indicated in Section 2.2 (see Step 7 of Worksheet #11) to address potential gaps in the monitoring network coverage and to respond to the possibility that the location of the highest concentrations in air may vary throughout the day. This section also states, "Historical knowledge of meteorological patterns during prescriptive conditions along with a review of historical air monitoring results for the candidate stations were utilized to pre-select a candidate station from the five available candidate stations." However, the selected candidate location is not specified and rationale for why the location was selected to address data gaps and the potential variability of the highest concentrations is not provided. Further, Section 2.5 (Worksheets #14 and #16) indicates that the air monitoring team will recommend the candidate location prior to burn ignition. However, decision criteria for how this location will be selected are not provided in the QAPP. Please revise the QAPP to consistently indicate if the candidate location has been determined. If the location has been selected, please also revise the QAPP to specify the selected candidate location and the rationale for why it was selected. Alternatively, if the location has not yet been selected, please revise the QAPP to include decision statements for how the candidate station locations will be selected prior to burn ignition.

### **Response to General Comment 4:**

As stated earlier, the current network consists of six pre-selected (or fixed) stations, supplemented by one additional station that is deployed on the day before the planned burn. Previously the network consisted of five pre-selected (or fixed) and two additional (selected from several candidates) locations. One of the previous "candidate" locations was converted to "pre-selected" in 2015 based on historical knowledge of meteorological patterns during prescriptive conditions along with a review of historical air monitoring results for the candidate stations. To clarify, the sentence (in Worksheet #18) will be relocated to "additional background summary" in Attachment 4. To address potential gaps in the monitoring network, on the day before the

## RESPONSES TO COMMENTS

planned prescribed burn, one of the five candidate locations will be selected for use based on the meteorological conditions anticipated for the burn day (next day). KEMRON will provide a recommendation and rationale for the selection to the Army. The candidate station selections are then provided to the EPA and DTSC, as well as MBARD, for their review.

### **General Comment 5:**

The timing of the 24-hour sample is stated to start upon ignition of the burn and the 24-hour average will be compared to the 24-hour National Ambient Air Quality Standard (NAAQS) of 35  $\mu\text{g}/\text{m}^3$ . However, since the monitoring stations are not located directly next to the burned areas, it will likely take a certain amount of time for the released emission to transport to the monitoring stations. Also, results for comparison to the NAAQS are typically collected from midnight to midnight. Further, the method to be used is not an EPA-designated Federally Reference or Equivalent Method, so it is unclear if the data collected will be comparable to the NAAQS. Please revise the QAPP to provide the rationale for the proposed timing of the sample collection and why the collected data will be sufficient for comparison to the NAAQS.

### **Response to General Comment 5:**

As described in Worksheet #11, DQO Step 3, the 24-hour National Ambient Air Quality Standard for  $\text{PM}_{2.5}$  at 35  $\mu\text{g}/\text{m}^3$  was selected as the screening level for this program. The 24-hour monitoring interval is designed to capture the particulate matter present at the sampling locations during the two major phases of the burn events: the active ignition phase and the smolder phase. All monitoring units will use the same monitoring interval starting at the time of ignition. The 24-hour average results allow for comparison to the 24-hour based screening level.

The E-BAM is not currently designated as an EPA Federal Equivalent Method (FEM) for continuous monitoring of  $\text{PM}_{2.5}$ . This prescribed burn air monitoring program is event-specific and is not part of the state's regulatory compliance network for ambient air quality, therefore, the monitoring units do not need to be Federal Reference Method (FRM) or FEM. The E-BAM operations manual (Attachment 2) states that the unit is designed to accurately predict FRM or FEM measurements when operated in accordance with the manual. The E-BAM is intended as a rapid-deployment particulate monitor and is appropriate for use such as monitoring of prescribed burn events. The MBARD considers E-BAM as a portable air monitoring device that can provide precise, real-time measurement of fine particulate matter, and uses several units to conduct  $\text{PM}_{2.5}$  monitoring during prescribed burn and other air quality events (such as wildfires) in the local air basin.

### **General Comment 6:**

## RESPONSES TO COMMENTS

The measurement heights of the Environmental Proof Instrument Beta Attenuation Monitor (E-BAM) are identified as two (2) to 15 meters above ground level (agl), but it is unclear why an upper height level of 15 meters was selected. Since the source of the particulates is likely at ground level (i.e., burning vegetation) and the purpose of the collected data is to assess the impact on human health, it appears that all E-BAMs should be limited to the breathing zone. Please revise the QAPP to use a lower range of proposed heights for the E-BAMs (e.g., 2 to 5 meters agl).

### **Response to General Comment 6:**

All E-BAM monitoring units will be deployed in a manner that the sampling point will be located 2 to 5 meters agl with the exception of the candidate location located at the MBARD office (CS-1). The measurement height range of 2 to 15 meters agl (specified in Worksheets #14 and #16) is based on the E-BAM user manual in Attachment 2. This is consistent with siting criteria for probe height in the EPA handbook provided in Attachment 1. The EPA guidance specifies the probe height of 2 to 15 meters for neighborhood or larger scale PM<sub>2.5</sub> monitoring sites, and additional considerations when the sampling location is near obstacles such as a building.

### **General Comment 7:**

Section 6.6, Data Usability Assessment (Worksheet #37), discusses evaluating precision during testing and calibration of the E-BAMs. However, this section does not discuss the analysis of an additional E-BAM at one of the locations during the entire burn event, which would assess the precision of the results obtained for the event (i.e., an actual field duplicate). Please revise the QAPP to include a duplicate E-BAM at one of the sampling locations, so that the results of both instruments may be compared for field duplicate precision, or to provide justification for why this is not necessary.

### **Response to General Comment 7:**

As described in Worksheet #37, a co-located field duplicate test will be performed in advance of a prescribed burn. This test will consist of two E-BAM units set up and run side by side at the same location for 24 hours. The results of this test will be included in the air monitoring report. We will not have a field duplicate during the monitoring events. The description of the co-located field duplicate test in Worksheet #37 will be updated for clarification.

### **General Comment 8:**

The data validation procedures are not discussed in sufficient detail in the QAPP. Data validation will be performed by the Project Chemist and is stated to be a review for outliers from the rolling averages and a review of any power outages or other instrument errors that may introduce bias into the results. In addition, a manual recalculation may be performed without the

## RESPONSES TO COMMENTS

outlier data. However, it is unclear how these outliers will be determined and when the recalculation will be performed. Further, Worksheet #37 indicates that data impacted by poor accuracy will also be qualified and references templates in Attachment 2, but other QAPP worksheets do not discuss applying qualifiers as part of the validation. Please revise the QAPP to provide detailed data validation procedures and include information for how qualifiers will be applied to the data. Alternatively, provide specific references to where this information may be found.

### **Response to General Comment 8:**

The QAPP will be updated to state the Project Chemist will perform data verification rather than validation. Quality control and quality assurance will be met by ensuring the proper field calibrations, pump test, flow checks and audits are performed at periodic intervals (See *Maintenance Item list on page 54 of the EBAM Manual*). This includes leak checks, nozzle/vane cleaning, ambient temperature and pressure sensor audits. Flow audits and calibrations will be performed using a traceable standard flow audit device. Span Membrane Test will also be conducted which consist of a 4 Step zero and span calibration of the instrument, this test is pass/fail. Once all initial and preparatory phase inspections, calibrations, and testing are successfully completed the instrument is ready for service. During the follow-up phase any errors encountered during the set-up and operation of the E-BAM will be reviewed. All data points collected during a period in which the instrument falls out of normal operating parameters will be discarded. Please see the E-BAM audit checklist referenced in Worksheet #28.

### **Specific Comment 1:**

Section 1.4, Communication Pathways (Worksheet #6), Page 8: This worksheet does not indicate that regulatory agencies will be notified that significant corrective actions are needed or when changes to the Work Plan occur in the field. Please revise the table to specify that the regulatory agencies will be notified of significant corrective actions and when changes to the Work Plan occur, and include the form of communication and timeframe for this notification.

### **Response to Specific Comment 1:**

The QAPP table will be revised to state fieldwork variances and notices of corrective action requests will be forwarded to the regulatory agencies within 7 business days of issuance of a fieldwork variance or corrective action request.

### **Specific Comment 2:**

Section 2.1, Conceptual Site Model (Worksheet #10), Page 10: The second paragraph of the Background Information subsection states, "The military conducted munitions-related activities

## RESPONSES TO COMMENTS

(e.g., live-fire training) on the facility and as a result MEC [munitions and explosives of concern] including UXO and discarded military munitions (DMM) may be present in parts of the former Fort Ord.” While this statement is generally correct, it does not include the potential presence of munitions constituents (MC) that are present in high enough concentrations to pose an explosive hazard. As this level of concentration of MC is the third component of the definition of MEC (i.e., MEC is unexploded ordnance [UXO], discarded military munitions [DMM], and MC present in high enough concentrations to pose an explosive hazard), it should also be included in the cited statement. Please revise the noted sentence to include the MC component of MEC as being potentially present in parts of the former Fort Ord.

### **Response to Specific Comment 2:**

The cited statement will be revised to “The military conducted munitions related activities (e.g., live-fire training) on the facility and as a result MEC may be present in parts of the former Fort Ord.”

### **Specific Comment 3:**

Section 2.2, Project Data Quality Objectives (Worksheet #11), Page 14: The areal extent of the study is not defined in Step 4: Define the Boundaries of the Study. The text states that the study boundary is the “area downwind of the prescribed burn events that would be potentially impacted by the presence of smoke.” However, the estimated impacted area is not specified and it is unclear how far and in which direction(s) the smoke is likely to extend. If the impacted area cannot be estimated, the text should discuss how the impacted area will be determined. Please revise this section to discuss the estimated impacted area and/or how this area will be determined.

### **Response to Specific Comment 3:**

The monitoring network provides broad coverage surrounding the burn units. Monitoring units are placed in areas within or adjacent to populated areas that are likely to experience the presence of smoke. Based on historical knowledge of meteorological patterns, the surface wind direction is expected to shift during the course of the burn event. The monitoring locations are anticipated to be downwind from the burn area during portions of the monitoring interval, and would capture areas of maximum impact. The program is not intended to delineate the limits of smoke travel.

### **Specific Comment 4:**

Section 2.2, Project Data Quality Objectives (Worksheet #11), Page 15: The first paragraph in Step 6: Specify Performance or Acceptance Criteria states that the limits on decision errors are from the potential outcomes of the 2013 prescribed burn air monitoring lessons learned, but

## RESPONSES TO COMMENTS

further information for the lessons learned is not provided. Please revise this section to clarify how the 2013 prescribed burn air monitoring lessons learned will be used to provide the limits on decision errors.

### **Response to Specific Comment 4:**

The lessons learned from the 2013 prescribed burns are summarized in the Prescribed Burn After-Action Report for Units 7 and 10 (Administrative Record number: OE-0812B). The prescribed burn program incorporates the current industry best practices for wildland prescribed burns. The highest and most important goals are to conduct the burn operations without injuries to personnel or surrounding communities, and to hold the burn within the established containment lines, thus minimizing smoke impacts. The Prescribed Burn After-Action Report noted that the screening level was exceeded at some air monitoring locations for the first burn event, which was executed under prescribed conditions and generally considered successful. The screening level was exceeded at several monitoring locations for the second burn event, which burned 100 additional acres and extended the burning into a period of less than desirable conditions. The lessons learned identified potential measures that can be considered in future burns to reduce the risk of an escape and to shorten the smolder period to reduce smoke impacts. The cited sentence will be deleted, since the lessons learned from the 2013 prescribed burns are not part of the performance criteria for the air monitoring program.

### **Specific Comment 5:**

Section 2.3, Measurement Performance Criteria (Worksheet #12), Pages 18 to 19: This section provides specifications for the E-BAMs, but it is unclear how it will be ensured that these specifications are met. For example, it is unclear what quality control (QC) measurements/samples may be used to ensure a system accuracy of 10% for each hourly measurement. Please revise the QAPP to include the QC samples/measurements that will be used to ensure the quality of the data collected.

### **Response to Specific Comment 5:**

The E-BAM measures and records airborne PM<sub>2.5</sub> particulate concentration levels using the principle of beta ray attenuation. This method provides a simple determination of concentration in units of milligrams of particulate per cubic meter of air. A small <sup>14</sup>C (Carbon 14) element emits a constant source of high-energy electrons known as beta particles. These beta particles are detected and counted by a sensitive scintillation detector. A vacuum pump pulls a measured amount of dust-laden air through the filter tape, which is positioned between the source and the detector thereby causing an attenuation of the beta particle signal. The degree of attenuation of the beta particle signal is used to determine the mass concentration of particulate matter on the filter tape, and the volumetric concentration of particulate matter in ambient air. An in-depth



## RESPONSES TO COMMENTS

scientific explanation of the theory of operation and the related equations is included in the back of the E-BAM Manual. Complete descriptions of the measurement cycles are found in section 6 of the E-BAM manual.

As previously stated in response to general comment 8, the quality control and quality assurance will be met by ensuring the proper field calibrations, pump test, flow checks and audits are performed at periodic intervals (*See Maintenance Item list on page 54 of the EBAM Manual*). This includes leak checks, nozzle/vane cleaning, ambient temperature and pressure sensor audits. Flow audits and calibrations will be performed using a traceable standard flow audit device. Span Membrane Test will also be conducted which consist of a 4 Step zero and span calibration of the instrument, this test is pass/fail. Once all initial and preparatory phase inspections, calibrations, and testing are successfully completed the instrument is ready for service. During the follow-up phase any errors encountered during the set-up and operation of the E-BAM will be reviewed. All data points collected during a period in which the instrument falls out of normal operating parameters will be discarded.

Please see the E-BAM audit checklist referenced in Worksheet #28.

### **Specific Comment 6:**

Section 2.5, Project Tasks and Schedule (Worksheet #14 and #16), Page 23: This section indicates visual observations of the monitoring stations will be recorded and periodic checks of the sampling equipment will be performed during the burn event, but further information for the frequency of these checks is not provided. Please revise this section to specify how often the monitoring stations will be observed and checked during the burn event.

### **Response to Specific Comment 6:**

As described in Worksheets #14 and #16, after burn ignition, the sampling technicians will check the E-BAM units at least twice during the active ignition phase. Operation of the E-BAM units will be checked remotely by the Project Chemist who will access the data at least twice during the active ignition phase and at least twice more during the remainder of the monitoring period.

### **Specific Comment 7:**

Section 3.1, Sampling Locations and Methods (Worksheet #18), Page 28: The note at the bottom of this page states, "Adjustment may be needed to monition [sic] network locations for BLM Area B work areas will be considered in the future using the procedure explained above in this worksheet." However, this worksheet does not provide a specific procedure for adjusting the proposed monitoring locations. Please revise this section to specifically discuss how and why



## RESPONSES TO COMMENTS

the monitoring network may be adjusted. Also, please revise the quoted sentence to clarify its meaning.

### **Response to Specific Comment 7:**

Prescribed burns are identified as part of the planned remedy for BLM Area B. As shown in Figure 2-1, BLM Area B is located to the north of the Impact Area MRA. The burn prescription for the prescribed burns in BLM Area B may differ slightly from those used in the Impact Area in the past; therefore, adjustments to the air monitoring network may be warranted. The statement will be revised to:

“Adjustments to the monitoring network will be considered for future prescribed burns in BLM Area B.”

### **Specific Comment 8:**

Section 4.2, Field Quality Control Summary (Worksheet #20), Page 30: This table indicates seven collocated samples will be collected for the seven primary sampling locations, but also indicates that a total of seven samples will be collected. Please revise this table to resolve this discrepancy in the number of primary, collocated, and total samples that will be collected.

### **Response to Specific Comment 8:**

The number of co-located samples will be revised to zero.

### **Specific Comment 9:**

Section 6.6, Data Usability Assessment (Worksheet #37), Pages 45 to 47: The discussion of the assessments of sensitivity, precision, accuracy, representativeness, completeness, and comparability (PARCCS) indicate that the results of these evaluations will be reported in the After-Action Report, but it is unclear if the After-Action Report will simply summarize the data usability conclusions, or if it will discuss how these evaluations were performed along with sufficient information to support the data usability conclusions. Please revise Worksheet #37 to indicate that the After-Action Report will discuss how PARCCS were evaluated, along with sufficient information to support the data usability conclusions.

### **Response to Specific Comment 9:**

The references in this section to the After-Action Report will be replaced with air monitoring report. This section will simply summarize the data usability conclusions because all data points collected during a period in which the instrument falls out of normal operating parameters will be discarded.

## RESPONSES TO COMMENTS

### **Specific Comment 10:**

Section 6.6, Data Usability Assessment (Worksheet #37), Page 47: The discussion of completeness does not specify the completeness goal. Please revise this section to include the completeness goal for the project.

### **Response to Specific Comment 10:**

The goal is to collect a 24-hour data from each deployed sampling station during each burn event. All data points collected during a period in which the instrument falls out of normal operating parameters will be discarded. The air monitoring report will document the percent completeness value by dividing the number of acceptable hourly sample results by the total number of hours planned for this investigation.



## RESPONSES TO COMMENTS

Documents: Draft Final, MRS-BLM Units 25 and 31 Prescribed Burn Plan, Former Fort Ord, California  
Draft Final, Site-Specific Work Plan Munitions and Explosives of Concern Remedial Action, MRS-BLM Units 25 and 31, Former Fort Ord, California  
Draft, Quality Assurance Project Plan, Former Fort Ord, California, Volume II, Appendix C, Prescribed Burn Air Monitoring

Commenting Organization: Fort Ord Community Advisory Group (FOCAG)

Name: Mike Weaver

Date of Comments: September 02, 2016

### **General Comment 1:**

“The FOCAG's previous comments on these subject issues have been marginalized by KEMRON. The FOCAG's multiple concerns have been minimized. Responses to FOCAG letters have been vague and non-responsive, for example, your contractor, KEMRON's explanation as to the public's inability to find documents on both the fortordcleanup.com website and in the administrative record. KEMRON's explanation begs the question; Why would a member of the public call the Fort Ord Administrative Office to request assistance searching for a document they don't know exists?”

### **Response to General Comment 1:**

If a member of the public feels that he/she is unable to find documents on the fortordcleanup.com website, assistance is available by contacting the Administrative Record coordinator at 831-393-9693.

### **General Comment 2:**

“Multiple documents regarding essentially the same issues, the Fort Ord burns, (like the subject documents listed above) are sent to dissimilar distribution lists. Why? Only 10, 11, or 12 addresses are included in the distribution list for these Army training range land burn related documents. CalFire is not on any of the Distribution Lists. Why?”

### **Response to General Comment 2:**

The Army coordinates its environmental cleanup activities with various federal, state and local agencies and adjacent property owners as appropriate. For example, the Army coordinates its

## RESPONSES TO COMMENTS

planning, preparation and implementation of each prescribed burn with CalFire and local fire departments. These entities may or may not be identified in document distribution lists.

Documents generated as part of the Fort Ord environmental cleanup program (such as work plans and reports) are submitted to the regulatory agencies under the Federal Facility Agreement process. These documents are also made available in the Administrative Record. Documents in the Administrative Record are accessible to the public.

### **General Comment 3:**

“Searching for these documents in the Administrative record by the specific listed DCN on the respective documents, again turns up nothing found.”

### **Response to General Comment 3:**

Documents in the Administrative Record can be searched in a variety of ways: keyword, record type, author, author organization, date range, or any combination of the above. Members of the public who have questions about searching the Administrative Record may contact the Administrative Record coordinator for assistance.

The Army assigns the Administrative Record document number for each item in the Administrative Record, and the documents can be searched using the Administrative Record document number. Often, organizations have their own document control system and assign their document control number (DCN) to items submitted to the Army. Those DCNs are not used by the Army to track documents in the Administrative Record.

### **General Comment 4:**

“There is a sequence of Document Control Numbers missing from these three subject documents and missing from our FOCAG delivery list. These are respectively:

DCN: SH4914-098

DCN: SH4914-099

DCN: SH4914-100

DCN: SH4914-101

What are these documents?”

### **Response to General Comment 4:**

Please see response to comment 3.

## RESPONSES TO COMMENTS

### General Comment 5:

“Referencing Table 2, Previously Recovered MEC Items and Depths in Units 25 and 31

What are the estimated distances the following can travel, airborne, when set off by aluma-gel incinerated, intentional, and high heat fire?

Projectile 81 mm Mortar  
Signal Illumination ground parachute M131  
Projectile 37 mm, high explosive, MkII  
Projectile 75 mm, high explosive, Mk 1  
Various Grenade types”

### Response to General Comment 5:

Maximum Fragment Distances, Horizontal (MFD-H) are calculated for many ordnance types by Department of Defense. These distances are theoretical maximums for a fragment to travel. MFD-H's for the items listed in the question are included below.

Projectile 81 mm Mortar – 1579 ft for Projectile, 81mm, mortar, high explosive, M43A1 (largest MFD-H among various types of 81 mm mortars)  
Signal Illumination ground parachute M131 – not available  
Projectile 37 mm, high explosive, MkII – 982 ft  
Projectile 75 mm, high explosive, Mk 1 – 1873 ft  
Various Grenade types – 87 ft (applies to various types of hand grenades)

### General Comment 6:

“Will Army reconsider putting air monitoring equipment in better locations to more accurately measure the smoke impacts to off-site residential areas? Our understanding is the Air District is waiting for an Army determination on this. Because residential housing areas are most directly affected, offers from easily accessed private property locations should be considered. Don't you agree? If not, please give specific reasons why.”

### Response to General Comment 6:

The air monitoring network for the Fort Ord prescribed burn monitoring program is designed to include areas surrounding the burn area and are generally placed in areas within or adjacent to populated areas that are likely to experience the presence of smoke. The air monitoring locations adequately represent the areas in their immediate vicinities. As previously stated in response to similar FOCAG comments, placement of an air monitoring unit on private property is not as practical as compared to the planned locations. This network has been developed in

## RESPONSES TO COMMENTS

coordination with the regulatory agencies and the public, and has been updated based on comments and recommendations from the regulatory agencies.

### **General Comment 7:**

“Given the thousands of acres that have burned in both the Soberanes and Chimney fires in Monterey County, given the thousands of fire personnel that have been called in to assist on these fires, given the millions of dollars this is costing, and given the Army's poor fire record with their burns getting out of control, isn't it illogical to intentionally light a fire on dry California hillsides on former Fort Ord?”

### **Response to General Comment 7:**

The Army will not consider a prescribed burn unless all meteorological and fuel moisture requirements are met and adequate fire resources are available. The conditions under which the Army will execute a prescribed burn at Fort Ord are described in the prescribed burn plan.