

**Quality Assurance Project Plan**  
**Former Fort Ord, California, Volume I**  
**Appendix D, Revision 4**  
**Operable Unit 2 Landfills**



Prepared for:  
**U.S. Army Corps of Engineers**  
Sacramento District  
1325 J Street  
Sacramento, CA 95814-2922



On behalf of:  
**U.S. Department of the Army**  
Fort Ord BRAC  
4463 Gigling Road, Room 101  
Seaside, CA 93955

USACE Contract No. W91238-C-14-0048  
Amendment No. P00003  
Task No. 8



Prepared by:  
**Ahtna Environmental, Inc.**  
296 12<sup>th</sup> Street  
Marina, CA 93933-6001

Report Date: **December 18, 2019**  
Report Version: **Draft Final**

## Table of Contents

Acronyms and Abbreviations .....	iv
1.0 Introduction .....	1
2.0 Project Management .....	2
2.1 Worksheets #1 and #2: Title and Approval Page .....	2
2.2 Worksheets #3 and #5: Project Organization and QAPP Distribution.....	5
2.3 Worksheets #4, #7 and #8: Personnel Qualifications and Sign-off Sheet .....	6
2.4 Worksheet #6: Communication Pathways .....	9
2.5 Worksheet #9: Project Planning Session Summary.....	12
3.0 Project Quality Objectives .....	13
3.1 Worksheet #10: Conceptual Site Model .....	13
3.1.1 Background and History.....	13
3.1.2 Sources of Known or Suspected Hazardous Waste .....	15
3.1.3 Known Contaminants .....	15
3.1.4 Fate and Transport Considerations .....	15
3.1.5 Potential Receptors and Exposure Pathways .....	16
3.1.6 Land Use Considerations .....	16
3.1.7 Physiography and Topography .....	16
3.1.8 Geology and Hydrogeology.....	17
3.2 Worksheet #11: Project/Data Quality Objectives .....	18
3.2.1 DQO #1: TTU Source Testing.....	18
3.2.2 DQO #2: Operational Influent LFG Testing .....	21
3.2.3 DQO #3: Compliance Perimeter Probes.....	24
3.2.4 DQO #4: Monitoring Probes and Vents .....	26
3.3 Worksheet #12: Measurement Performance Criteria .....	29
3.3.1 Analytical Group/Method: Fixed Gases/ASTM D1945.....	29
3.3.2 Analytical Group/Method: Sulfur Gases/ASTM D5504.....	29
3.3.3 Analytical Group/Method: Volatile Organic Compounds (VOC)/TO-15 .....	30
3.4 Worksheet #13: Secondary Data Uses and Limitations .....	32
3.5 Worksheets #14 and #16: Project Tasks and Schedule .....	33
3.6 Worksheet #15: Laboratory-Specific Detection/Quantitation Limits <sup>1,2</sup> .....	34
3.6.1 Analytical Group/Method: Fixed Gases/ASTM D1945.....	34
3.6.2 Analytical Group/Method: Sulfur Gases/ASTM D5504.....	35
3.6.3 Analytical Group/Method: VOC/TO-15 – DQO #1: TTU Source Testing and DQO #2: Operational Influent LFG Testing (see Worksheet #11) .....	36
3.6.4 Analytical Group/Method: VOC/TO-15 – DQO #3: Compliance Perimeter Probes (see Worksheet #11).....	38
3.6.5 Mobile Laboratory Analytical Group/Methods – DQO #1: TTU Source Testing (see Worksheet #11).....	40
4.0 Sample Design .....	41
4.1 Worksheet #17: Sampling Design and Rationale .....	41
4.2 Worksheet #18: Sampling Locations and Methods.....	42
4.2.1 Operable Unit 2 Landfills .....	42
4.2.2 Thermal Treatment Unit/Extraction Points .....	50
5.0 Sampling Requirements.....	53

---

5.1	Worksheets #19 and #30: Sample Containers, Preservation, and Hold Times .....	53
5.2	Worksheet #20: Field Quality Control Summary.....	54
5.3	Worksheet #21: Field SOPs/Methods .....	55
5.4	Worksheet #22: Field Equipment Calibration, Maintenance, Testing, and Inspection.....	56
6.0	Analytical Requirements.....	58
6.1	Worksheet #23: Analytical SOPs .....	58
6.2	Worksheet #24: Analytical Instrument Calibration.....	59
6.3	Worksheet #25: Analytical Instrument and Equipment Maintenance, Testing, and Inspection .....	62
6.4	Worksheets #26 and #27: Sample Handling, Custody, and Disposal .....	63
6.5	Worksheet #28: Analytical Quality Control and Corrective Action .....	64
6.5.1	Analytical Group/Method/SOP: Fixed Gases/ASTM D1945/SOP #54.....	64
6.5.2	Analytical Group/Method/SOP: Sulfur Gases/ASTM D5504/A.5504.04.....	65
6.5.3	Analytical Group/Method/SOP: VOCs/TO-15/SOP #6 .....	66
7.0	Data Management and Data Review .....	67
7.1	Worksheet #29: Project Documents and Records .....	67
7.2	Worksheets #31, #32 and #33: Assessments and Corrective Action .....	68
7.3	Worksheet #34: Data Verification and Validation Inputs.....	71
7.4	Worksheet #35: Data Verification Procedures.....	72
7.5	Worksheet #36: Data Validation Procedures.....	73
7.6	Worksheet #37: Data Usability Assessment.....	74
8.0	References .....	79

## **Figures**

- 1 Location Map
- 2 Landfill Gas Monitoring Locations
- 3 Landfill Gas Extraction and Treatment System

## **Attachments**

- A Standard Operating Procedures
- B Analytical Laboratory Information
- C Field Documentation Forms
- D Three Phase Quality Control Process and Documentation
- E Electronic Data Deliverable File Specifications
- F Responses to Comments on the QAPP, Volume I, Appendix D, Draft Revision 4, Operable Unit 2 Landfills

## Acronyms and Abbreviations

°F	degrees Fahrenheit
µg/m <sup>3</sup>	micrograms per cubic meter
%	percent
%D	percent difference
%R	percent recovery
%v	percent [by] volume
ADR	Automated Data Review
Ahtna	Ahtna Environmental, Inc.
Air District	Monterey Bay Air Resources District
ARAR	applicable or relevant and appropriate requirement
Army	U.S. Department of the Army
bgs	below ground surface
BRAC	Base Realignment and Closure
Btu	British thermal unit(s)
Btu/hr	Btu per hour
CAMU	Corrective Action Management Unit
CAS	Chemical Abstracts Service
CCR	California Code of Regulations
CCV	continuing calibration verification
CERCLA	Comprehensive Environmental Response, Compensation, and Liability Act
CH <sub>4</sub>	methane
CO	carbon monoxide
CO <sub>2</sub>	carbon dioxide
COC	chemical of concern
CCRWQCB	Central Coast Regional Water Quality Control Board
DoD	Department of Defense
DQI	data quality indicator
DQO	data quality objective
DTSC	California Department of Toxic Substances Control
EDD	electronic data deliverable
ELAP	Environmental Laboratory Accreditation Program
EP	extraction point
EPA	U.S. Environmental Protection Agency
ESD	Explanation of Significant Differences
Eurofins	Eurofins Air Toxics, Inc.
EW	extraction well
FODIS	Fort Ord Data Integration System
FTL	Field Team Lead
GAC	granular activated carbon
GC	gas chromatograph
GCMS	gas chromatograph(y)/mass spectroscop(e/y)
H&S	Health and Safety
HHRA	human health risk assessment
HMP	Habitat Management Plan
ICAL	initial calibration
ICV	initial calibration verification

## Acronyms and Abbreviations (continued)

lb/MMBtu	pounds per million British thermal units
LCS	laboratory control sample
LDC	Laboratory Data Consultants
LFG	landfill gas
LOD	limit of detection
LOQ	limit of quantitation
MSL	mean sea level
N <sub>2</sub>	nitrogen
NA	not applicable
NELAP	National Environmental Laboratory Accreditation Program
NMOC	non-methane organic compounds
NO	nitrogen oxide
NOx	nitrogen oxides
O&M	operations and maintenance
O <sub>2</sub>	oxygen
OU2	Operable Unit 2
PARCCS	precision, accuracy, representativeness, comparability, completeness, and sensitivity
PCE	tetrachloroethene
PDL	project decision limit
PM	Project Manager
ppbv	parts per billion by volume
ppmv	parts per million by volume
QA	quality assurance
QAPP	Quality Assurance Project Plan
QC	quality control
QSM	Quality Systems Manual
RI	Remedial Investigation
ROD	Record of Decision
RPD	relative percent difference
RRT	relative retention time
RSD	relative standard deviation
RSL	regional screening level
SARA	Superfund Amendment and Reauthorization Act
scfm	standard cubic feet per minute
SL	screening level
SO <sub>2</sub>	sulfur dioxide
SOP	standard operating procedure
SSHO	Site Safety and Health Officer
THC	total hydrocarbons
TTU	thermal treatment unit
USACE	U.S. Army Corps of Engineers
VD	Passive Vent in Area D
VF	Passive Vent in Area F
VOC	volatile organic compound

## 1.0 Introduction

This Quality Assurance Project Plan (QAPP)<sup>1</sup> Appendix D Revision 4 describes the planning, implementation, acquisition, and assessment of data using effective methodologies and thorough quality assurance (QA) and quality control (QC) procedures to be used during sampling and analytical activities, so the data generated is accurate, precise, complete, representative of field conditions, and of sufficient quality to support project decisions. Ahtna Environmental, Inc. (Ahtna), on behalf of the U.S. Army Corps of Engineers (USACE), will implement the QAPP for sampling and laboratory analysis activities related to operations and maintenance (O&M) of the Operable Unit 2 (OU2) Landfills and landfill gas (LFG) extraction and treatment system at the Former Fort Ord, California (Figure 1). This QAPP also includes information for data management and analysis in support of the sampling program. The QAPP was updated and revised to:

- Update the TO-15 target analyte list based on the analytical results for samples collected in June 2019;
- Provide the Field Sampling Procedure Using Summa Canisters with RAVEqc Quick-Connect in Attachment A; and
- Update the laboratory analyses certifications in Attachment B.

The O&M activities are in accordance with the Record of Decision (ROD), Operable Unit 2, Fort Ord Landfills, Fort Ord, California (OU2 Landfills ROD; Army, 1994) and the *Operation and Maintenance Plan, Operable Unit 2 Landfills, Former Fort Ord, California* (O&M Plan; Shaw, 2008a). This document is intended for use by field operators, supervisors, and data processors and managers responsible for implementing and coordinating field activities for the project.

---

<sup>1</sup> This document is Appendix D to the *Quality Assurance Project Plan, Superfund Response Actions, Former Fort Ord, California, Volume I*. Volume I is also the governing document for sampling and analysis of groundwater (Appendix A), soil (Appendix B), and soil gas (Appendix C). Volume II of the QAPP pertains to the former Fort Ord military munitions response program.

## 2.0 Project Management

### 2.1 Worksheets #1 and #2: Title and Approval Page

**Site Name/Project Name:** Operable Unit 2 (OU2)

**Site Location:** Former Fort Ord, California

**Document Title:** Quality Assurance Project Plan, Former Fort Ord, California, Volume I, Appendix D, Draft Final Revision 4, Operable Unit 2 Landfills

**Lead Organization:** U.S. Army Corps of Engineers

**Preparer's Name, Organization, and Contact Info:** Eric Schmidt, Ahtna  
296 12<sup>th</sup> St, Marina, CA 93933.  
(831) 384-3735, eschmidt@ahtna.net

**Preparation Date:** December 18, 2019

**Revision Number:** 4

Project Role	Name Organization	Signature	Date
Investigative Organization's Project Manager	Derek S. Lieberman Ahtna		
Investigative Organization's Program Chemist	Christopher Ohland Ahtna		
Lead Organization's Technical Lead	Alex Kan USACE		
Lead Organization's Project Chemist	Jonathan Whipple USACE		



**Plans and reports from previous investigations relevant to this project:**

**Site Name/Project Name:** Former Fort Ord/Superfund Response Actions

**Site Location:** Monterey County, California

**Site Number/Code:** Not Applicable (N/A)

**Operable Units:** OU2

**Contractor Name:** Ahtna Environmental, Inc.

**Contract Number:** W91238-14-C-0048

**Contract Title:** Former Fort Ord Basewide Groundwater and Soil Vapor Treatment and Monitoring, Former Fort Ord, California

**Work Assignment Number:** N/A

Uniform Federal Policy for Quality Assurance Project Plans, Optimized UFP-QAPP Worksheets, March 2012, Revision 1

**Guidance used to prepare QAPP:** Department of Defense (DoD) Quality Systems Manual (QSM) for Environmental Laboratories, Version 5.3, May 2019

DoD General Data Validation Guidelines, Environmental Data Quality Workgroup, February 2018

**Regulatory Program:** Comprehensive Environmental Response Compensation and Liability Act (CERCLA) as amended by Superfund Amendment and Reauthorization Act (SARA)

**Approval Entities:** U.S. Environmental Protection Agency (EPA), California Department of Toxic Substance Control (DTSC), and Regional Water Quality Control Board, Central Coast Region (CCRWQCB)

**Data Users:** U.S. Department of the Army (Army), USACE, EPA (and its consultant TechLaw, Inc.), DTSC, CCRWQCB, Army/USACE contractors, citizen groups, and members of the public

**Organizational partners (stakeholders) and connection with lead organization:** USACE, Army (lead agency/owner), EPA (lead oversight agency), DTSC (support agency), and CCRWQCB (support agency)

**The QAPP is (select one):** Generic: \_\_\_\_\_ Project Specific:  X \_\_\_\_\_

Title	Company	Date
Record of Decision Operable Unit 2, Fort Ord Landfills Fort Ord, California	U.S. Department of the Army (Army)	07/15/1994
Explanation of Significant Differences, Operable Unit 2, Fort Ord Landfill	Army	08/03/1995

Title	Company	Date
Explanation of Significant Differences, No Further Action for Munitions and Explosives of Concern, Landfill Gas Control, Reuse of Treated Groundwater, Designation of Corrective Action Management Unit (CAMU) Requirements as Applicable or Relevant and Appropriate Requirements (ARARs), OU2, Fort Ord Landfills	Army	10/04/2006
Operation and Maintenance Plan Operable Unit 2 Landfills Former Fort Ord, California Revision 2	Shaw Environmental, Inc.	09/04/2008
Quality Assurance Project Plan, Former Fort Ord, California, Volume I, Appendix D, Final Revision 1, Operable Unit 2 Landfills	Ahtna	09/04/2016
Quality Assurance Project Plan, Former Fort Ord, California, Volume I, Appendix D, Final Revision 2, Operable Unit 2 Landfills	Ahtna	09/11/2017
Quality Assurance Project Plan, Former Fort Ord, California, Volume I, Appendix D, Final Revision 3, Operable Unit 2 Landfills	Ahtna	05/31/2019
Operations and Maintenance Plan Revision 3 Operable Unit 2 Landfills Former Fort Ord, California	Ahtna	07/23/2019

## 2.2 Worksheets #3 and #5: Project Organization and QAPP Distribution

Reporting relationships between organizations involved in the project, including the lead organization, contractors, and subcontractor organizations are identified below:

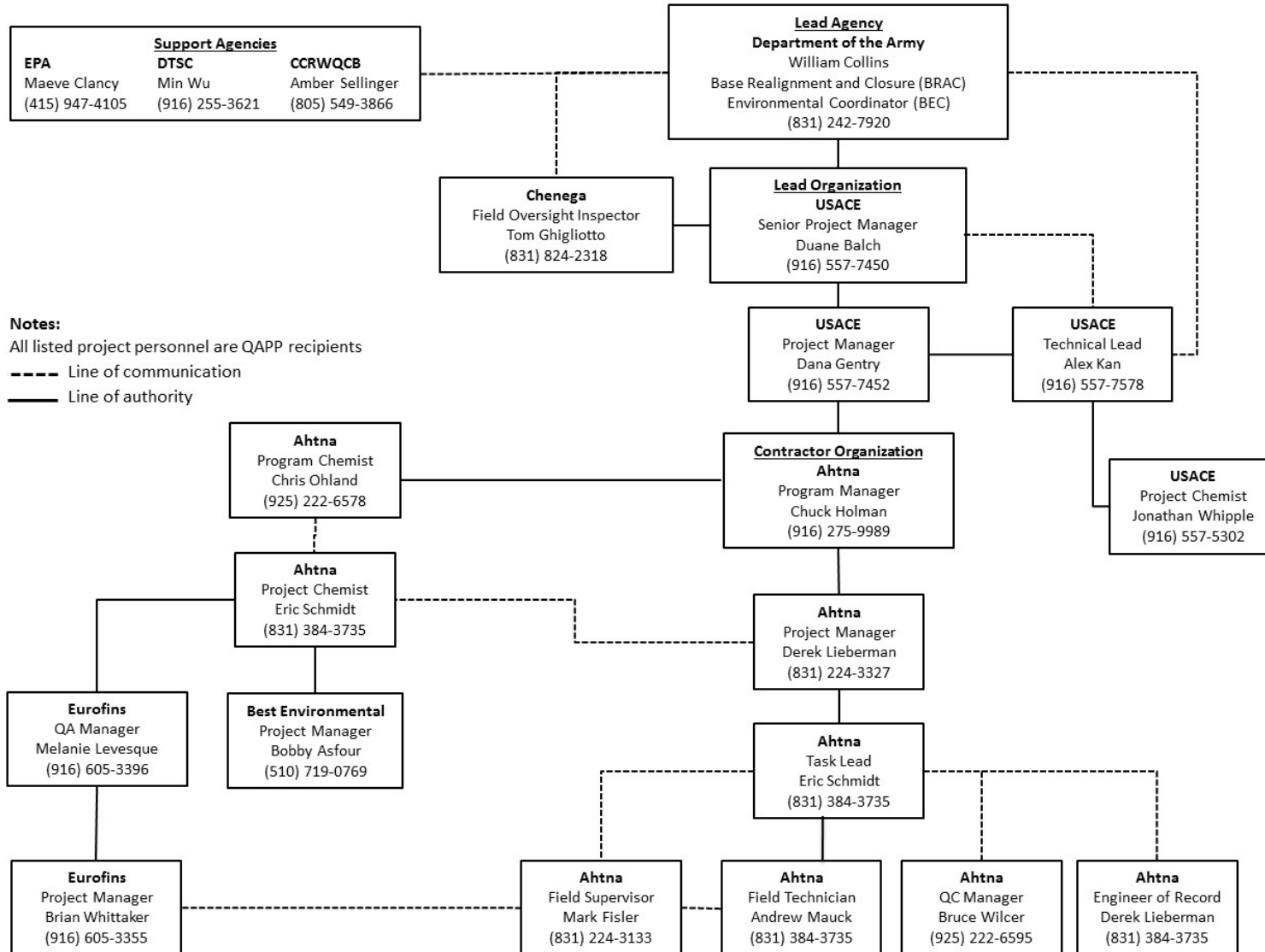

## 2.3 Worksheets #4, #7 and #8: Personnel Qualifications and Sign-off Sheet

### Ahtna

Name	Project Title/Role	Education/ Experience	Specialized Training/ Certifications <sup>1</sup>	Signature <sup>2</sup>	Date
Derek Lieberman	Project Manager/ Engineer of Record	Resume on file	First aid, CPR, MEC, PE, H&S, HAZWOPER		
Eric Schmidt	Project Chemist/Task Lead and Data Manager	Resume on file	First aid, CPR, MEC, HAZWOPER, CQM		
Mark Fisler	Field Supervisor	Resume on file	First aid, CPR, MEC, HAZWOPER, CQM		
Bruce Wilcer	QC Manager	Resume on file	HAZWOPER, CQM		
Andrew Mauck	Field Technician	Resume on file	First aid, CPR, MEC, HAZWOPER		

**Notes:**

<sup>1</sup>Specialized Training/Certifications Key:

CPR: cardiopulmonary resuscitation

CQM: Construction Quality Management.

H&S: health and safety training, including, but not limited to: hazard communication, fire extinguisher use, defensive driving, behavior-based safety, confined spaces.

HAZWOPER: 40-hour and current 8-hour annual refresher Hazardous Waste Operations and Emergency Response

MEC: munitions and explosives of concern recognition and safety training

PE: registered Professional Engineer

<sup>2</sup>Signatures indicate personnel has read and agree to implement this QAPP as written.

### Worksheets #4, #7 and #8: Personnel Qualifications and Sign-off Sheet

#### Laboratory: Eurofins Air Toxics, Inc. (Eurofins)

Name	Project Title/Role	Education/Experience	Specialized Training/Certifications	Signature <sup>1</sup>	Date
Brian Whittaker	Project Manager	Resume on file	Not applicable		
Melanie Levesque	QA Manager	Resume on file	Not applicable		

**Notes:**

<sup>1</sup>Signatures indicate personnel has read and agree to implement this QAPP as written.

## Worksheets #4, #7 and #8: Personnel Qualifications and Sign-off Sheet

### Mobile Laboratory: Best Environmental

Name	Project Title/ Role	Education/ Experience	Specialized Training/ Certifications	Signature <sup>1</sup>	Date
Bobby Asfour	Project Manager	Resume on file	Not applicable		

**Notes:**

<sup>1</sup>Signatures indicate personnel has read and agree to implement this QAPP as written.

## 2.4 Worksheet #6: Communication Pathways

Communication Driver	Organization	Name	Contact Information	Procedure (timing, pathways, documentation, etc.)
Regulatory agency interface	Army	William Collins	831-242-7920	Project materials and information will be submitted to EPA, DTSC, and CCRWQCB as appropriate by William Collins via email or hardcopy.
Point of contact with Army Base Realignment and Closure (BRAC) Office	USACE	Alex Kan	916-956-2752	Materials and information regarding the project will be forwarded to Army BRAC Office through USACE Technical Lead.
Point of contact for the Lead Organization Technical Lead	Ahtna	Derek Lieberman	831-384-3735	Oversees and reviews materials and information about the project.
Status Reports	Ahtna	Derek Lieberman	831-384-3735	Derek Lieberman will provide updates to USACE during weekly status calls.
Stop work due to safety issues	Ahtna	Any person	831-384-3735	Any individual has the ability to stop work based on an unsafe work condition, or a potential for an unsafe work condition.
QAPP variances in the field	Ahtna	Mark Fislér Andrew Mauck	831-384-3735	Notify Eric Schmidt by telephone or email of variances to QAPP made in the field and the reasons within 24 hours. Eric Schmidt will notify Alex Kan and the USACE Project Chemist about QAPP variances that could affect the data.
QAPP modifications and contract compliance	Ahtna	Eric Schmidt	831-384-3735	Prepares QAPP and QAPP amendments; issue valid QAPP variances with input from Project Manager (PM) and Sampling Team Lead. Assures Ahtna compliance with contract requirements. Eric Schmidt will notify Alex Kan and the USACE Project Chemist about QAPP modifications that could affect the data.
Field and analytical corrective actions	Ahtna	Chris Ohland	925-222-6593	The need for corrective action for analytical issues will be determined by Chris Ohland in

Communication Driver	Organization	Name	Contact Information	Procedure (timing, pathways, documentation, etc.)
				coordination with Alex Kan and the USACE Project Chemist.
QC and contract compliance	Ahtna	Bruce Wilcer	925-222-6856	Reviews project plans; assures Ahtna compliance with contract requirements.
Analytical contact with the field staff and laboratory	Ahtna	Eric Schmidt	831-384-3735	Oversees and reviews all analytical materials generated from the field and by the laboratory.
Reporting fixed lab data quality issues	Eurofins	Brian Whittaker Melanie Levesque	800-985-5955	QC issues with project field samples will be reported by the laboratory to Eric Schmidt within 2 business days. Identify required variances from QAPP. Eric Schmidt will report QC issues to Alex Kan and the USACE Project Chemist.
Reporting mobile lab data quality issues	Best Environmental	Bobby Asfour	510-719-0769	QC issues with mobile laboratory analysis will be reported to Eric Schmidt upon discovery. Identify required variances from QAPP and notify Alex Kan and the USACE Project Chemist.
Data import and export	Ahtna	Eric Schmidt	831-384-3735	Uploads field/fixed lab and data recorder data into the Fort Ord Data Integration System.
Hazardous or unsafe conditions that raise question of stopping work	Ahtna	Eric Schmidt Mark Fisler Andrew Mauck	831-384-3735	Confer with Derek Lieberman and/or the Ahtna Site Safety and Health Officer (SSHO) to determine whether work needs to be stopped; the Ahtna SSHO will report stop-work decision to the Ahtna PM.
Perform field QC checks to ensure proper sampling methods, custody procedures, packaging, and shipment are performed	Ahtna	Bruce Wilcer	925-222-6856	Report result of field checks to Derek Lieberman and Eric Schmidt.
Prepare initial write-up of field	Ahtna	Eric Schmidt	831-384-3735	Confer with Derek Lieberman on questions



<b>Communication Driver</b>	<b>Organization</b>	<b>Name</b>	<b>Contact Information</b>	<b>Procedure (timing, pathways, documentation, etc.)</b>
generated data to be included in final reports				and resolutions.
Database setup and data management planning	Ahtna	Eric Schmidt	831-384-3735	Provides information on sample and analytical reporting groups, and types of report tables required for project.
Data verification/data validation	Ahtna / Laboratory Data Consultants	Eric Schmidt	831-384-3735	Report result of analytical QC checks to Chris Ohland.
Data review issues and corrective actions	Ahtna	Eric Schmidt	831-384-3735	Report result of analytical QC corrective action to Chris Ohland and Derek Lieberman.

## 2.5 Worksheet #9: Project Planning Session Summary

**Date of Planning Session #1:** August 1, 2019

**Purpose:** Determine whether revisions are appropriate per data quality objectives (DQOs) identified in QAPP Worksheet #11.

### Participants:

Name	Title/Role	Affiliation	Telephone	email
Derek Lieberman	Project Manager	Ahtna	831-384-3735	dlieberman@ahtna.net
Eric Schmidt	Project Chemist/Task Lead	Ahtna	831-384-3735	eschmidt@ahtna.net

### Planning Session Summary:

- Reviewed contract requirements and QAPP schedule;
- Determined data review is necessary to evaluate changes in LFG monitoring frequency and target analyte lists per DQOs;

### Action Items:

Action	Responsible Party	Due Date
Data review to determine whether changes sampling frequency and target analyte lists are required for QAPP revision.	Eric Schmidt, Ahtna	August 7, 2019
Review QAPP for inconsistencies or errors and correct as needed.	Eric Schmidt, Ahtna	August 7, 2019
Update QAPP per results of data review and personnel changes.	Eric Schmidt, Ahtna	August 7, 2019
Internal Ahtna QC review of QAPP and issue preliminary draft QAPP for Army and USACE review.	Eric Schmidt, Ahtna	August 7, 2019

### 3.0 Project Quality Objectives

#### 3.1 Worksheet #10: Conceptual Site Model

##### 3.1.1 Background and History

The former Fort Ord is located in northwestern Monterey County, California, approximately 80 miles south of San Francisco. The OU2 Landfills formerly included six landfill areas (one area north and five areas south of Imjin Parkway) covering approximately 150 acres, including the immediate surrounding area (Figure 1). The former Area A Landfill, north of Imjin Parkway, was approximately 33 acres separated from the Areas B through F Landfills to the south of Imjin Parkway (Figure 2). The Areas B through F Landfills encompass approximately 120 acres of undeveloped land. The six landfill areas were used for residential and on-base waste disposal. The former Area A was used from 1956 to 1966. Areas B through F were operated from 1960 until 1987, when interim closure of the facility began, which effectively terminated waste disposal activities at the OU2 Landfills (Shaw, 2008a).

The remedial action at the former Area A was conducted from 1996 to 1998 in accordance with the requirements of the OU2 Landfills ROD (Army, 1994) and the *Explanation of Significant Differences, Consolidation of Remediation Waste in a Corrective Action Management Unit (CAMU), Operable Unit 2 Landfill* (CAMU ESD; Army, 1997a). Approximately 585,000 cubic yards of refuse were excavated during the remediation. This material was placed and compacted as part of the general fill in Areas B, C, D, and F of the OU2 Landfills (IT Corporation, 2001). Closure is being completed as a remedial action at the OU2 Landfills in accordance with the OU2 Landfills ROD (Army, 1994).

The selected remedial action presented in the OU2 Landfills ROD includes placing an engineered cover system over buried refuse at the OU2 Landfills. The *Record of Decision, Basewide Remedial Investigation Sites, Fort Ord, California* (RI Sites ROD; Army, 1997b) in conjunction with the CAMU ESD (Army, 1997a) and the *Explanation of Significant Differences, No Further Action for Munitions and Explosives of Concern, Landfill Gas Control, Reuse of Treated Groundwater, Designation of Corrective Action Management Unit (CAMU) Requirements as Applicable or Relevant and Appropriate Requirements (ARARs)* (Army, 2006) designate CAMU regulations as ARARs for the existing boundaries of Areas B through F. Such designation generally allows remediation waste to be placed at the OU2 Landfills and used as a foundation layer without triggering certain disposal regulations. Soil remedies for the RI Sites at the Former Fort Ord utilized the CAMU for placement of excavated soil and/or debris, which are managed, incorporated within the landfill foundation layer, and capped as part of the landfill.

The remedial actions for the debris and soil at the OU2 Landfills include a cover system, collection and removal of LFG (if necessary), institutional controls, and a groundwater extraction and treatment system for volatile organic compounds (VOCs). The Army completed construction of an engineered cover over Areas B through F from 1997 to 2002 (Shaw, 2005a) and began operating the groundwater extraction and treatment system in 1995. In 2001 the Army installed a pilot extraction and treatment system to mitigate LFG migration along the eastern perimeter of Area F where a residential area is located closest to the landfill (Shaw, 2005b). The system began operation on June 4, 2001 and included a series of LFG extraction wells (EWs), LFG treatment with granular activated carbon (GAC) to remove VOCs, and

potassium permanganate to remove vinyl chloride. Two 8-inch diameter perforated collector pipes, approximately 800 feet in total length, were installed in the foundation layer at Area E during construction in 2002 for possible future methane extraction. The collector pipes are collectively referred to as extraction point (EP) EP-36.

Based on the results of the pilot study, the extraction and treatment system was expanded by adding vertical extraction wells (EW) along the perimeter and within the interior of Area F, and replacing the existing treatment system with a thermal treatment unit (TTU), which started operation in April 2006. The TTU, unlike the GAC/potassium permanganate treatment system, removes and treats both VOCs and methane by combustion in an enclosed flare operating in excess of 1,400 degrees Fahrenheit (°F).

In 2008, an EW was installed in Area D to augment the methane output from the Area F extraction system. A conduit from EP-36 to the TTU also was installed as part of the LFG treatment system expansion (Shaw, 2008b). In April 2009, EP-36 was brought online to augment the methane output from the Area F extraction system. As part of Field Work Variance TII-138 to the O&M Plan (Shaw, 2008a), testing was performed on Area F passive vent (VF) VF-4 to determine if it was a viable source of methane that could be used in operation of the TTU. Results of this test determined that a significant increase in methane removal could be achieved through the addition of VF-4 into the extraction network. In June 2009, VF-4 was brought on line to augment the methane output from the Area F extraction system.

In February 2011, four additional passive vents in Areas D and F (VD-2, VD-3, VF-3, and VF-5) were converted to EPs to augment the methane output. These additions were documented in Field Work Variance TII-154 to the O&M Plan (Shaw, 2008a).

System monitoring includes all EPs and the combined collection points at the TTU. Since the remedy is being performed under the Comprehensive Environmental Response, Compensation, and Liability Act of 1980 (CERCLA; 42 USC 9601 et seq.), as amended by the Superfund Amendment and Reauthorization Act of 1986 (SARA), the Monterey Bay Air Resources District (Air District) does not have jurisdiction over these remedial actions, and a permit for the TTU and exhaust stack is not required. However, the Air District's substantive requirements are being implemented.

Due to the need for remediation at the Site 39 Inland Ranges, and the availability of additional remediation waste capacity at Area E, the Army proposed to place contaminated soil from the Site 39 Inland Ranges within the existing footprint of Area E as a vertical expansion. The Army prepared the *Record of Decision Amendment, Site 39 Inland Ranges, Former Fort Ord, California* (Army, 2009) to present the soil cleanup levels and the volume of soil to be addressed under the selected remedial action for the Site 39 Inland Ranges originally identified in the RI Sites ROD (Army, 1997b). Additional capacity at the OU2 Landfills was available by placing remediation waste within the existing Area E footprint on top of the existing engineered cover system. Construction of the vertical expansion involved placing additional remediation waste above the existing geomembrane and installing a new engineered cover consisting of a foundation layer, geomembrane, and vegetative layer over the remediation waste. The vertical expansion allows for placement of approximately 200,000 cubic yards of remediation waste in at least two phases. When the vertical expansion is complete, the additional remediation waste will be sealed above and below by a geomembrane. Phase 1 was completed in 2013

with approximately 150,000 cubic yards placed in the vertical expansion at Area E. Additional remediation of Site 39 and placement of soil in the Area E vertical expansion may be necessary for the future.

The technical assessment of the remedies for OU2 completed for the 4<sup>th</sup> Five-Year Review for the Fort Ord Superfund Site identified no issues for OU2. The OU2 remedies were deemed to be protective of human health and the environment and, in the interim, potential exposure pathways that could result in unacceptable risks are being controlled (Army, 2012).

### **3.1.2 Sources of Known or Suspected Hazardous Waste**

No detailed records were kept on the amount or types of wastes disposed of at the OU2 Landfills; however, household and commercial refuse, ash from incinerated infectious wastes, dried sewage sludge, demolition material, and small amounts of chemical waste (such as paint, waste oil, pesticides, electrical equipment, ink and epoxy adhesives) are believed to have been disposed of in the OU2 Landfills (Dames & Moore, 1993).

### **3.1.3 Known Contaminants**

Known contaminants at the OU2 Landfills are methane and VOCs in LFG. For methane, the primary release mechanism is emanation from decomposing organic waste. For VOCs, the primary release mechanisms are emanation (within LFG) and infiltration/percolation to groundwater.

### **3.1.4 Fate and Transport Considerations**

VOCs remaining in waste disposed of at the OU2 Landfills and VOCs detected in LFG have the potential to travel through soil pore space to exposure points via a number of mechanisms:

- Advection: mass transport due to bulk flow of water in which contaminants are dissolved.
- Dispersion: transport due to the groundwater flow whether or not a compound is dissolved.
- Diffusion: spreading of contaminants due to molecular diffusion in response to concentration gradients.
- Volatilization: loss of chemical vapor to the atmosphere.

VOCs naturally undergo biological degradation processes in soil, soil gas and groundwater; however, the rate of such degradation is limited by oxygen and nutrient sources depending upon the type of degradation that is occurring (aerobic vs. anaerobic). Further, degradation of compounds is dependent on the biological pathway available.

Groundwater contamination at OU2 affected the upper three groundwater aquifers as described in the *Final Remedial Investigation/Feasibility Study, Fort Ord, California, Volume II – Remedial Investigation Introduction and Basewide Hydrogeologic Characterization* (HLA, 1995). These three aquifers include the A-Aquifer, the Upper 180-Foot Aquifer, and the Lower 180-Foot Aquifer. In the vicinity of OU2, the tops of each of these aquifers typically are first encountered at depths of about 60 feet bgs, 150 feet bgs, and 250 feet bgs, respectively. In monitoring well MW-OU2-73-A, located at the OU2 Landfills Area F source area, tetrachloroethene and trichloroethene are below their Aquifer Cleanup Levels or not detected, but vinyl chloride is detected at the highest concentrations for the OU2 A-Aquifer. Vinyl chloride is a

breakdown product in the natural reductive dechlorination process and may indicate this process is occurring locally at OU2 Landfills Area F.

With implementation of the remedy as prescribed in the OU2 Landfills ROD (engineered landfill cover system, and groundwater extraction and treatment system) in addition to operation of the LFG extraction and treatment system, impacts to the underlying groundwater from the OU2 Landfills have been greatly mitigated.

### **3.1.5 Potential Receptors and Exposure Pathways**

A residential area is located adjacent to OU2 Landfills Area F, with the closest residence located approximately 368 feet from the OU2 Landfills perimeter. There is a potential for residents to be exposed to VOCs from inhalation of vapors in ambient air, which may enter buildings through open windows or ventilation systems. To evaluate risks associated with this scenario, the Army performed ambient air monitoring in 2000, 2001, 2002 and 2003 to determine LFG dispersion in ambient air on the east side of Area F. The data were used to complete a screening-level human health risk assessment (HHRA). The updated HHRA indicated that the OU2 Landfills are not a significant contributor of VOCs in ambient air or a significant risk to downwind receptors (Shaw, 2005c). The HHRA also noted that the LFG collection and treatment system installed at Area F prevents LFG from migrating off-site in the direction of the residential area. Since the onset of TTU operations, the methane concentrations in perimeter monitoring probes have remained below 5 percent (%) per the requirements of Title 27 California Code of Regulations (27CCR) Section 20921(a)(2) (Ahtna, 2017, 2018, and 2019).

### **3.1.6 Land Use Considerations**

The OU2 Landfills encompass approximately 120 acres of land that is undeveloped other than use as a landfill. A residential housing area for California State University Monterey Bay is located adjacent to OU2 Landfills Area F, with the closest residence located approximately 368 feet from the OU2 Landfills perimeter.

Other land immediately adjacent to the OU2 Landfills was transferred from the Army to the Fort Ord Reuse Authority in 2004 and 2006 and remains undeveloped. These parcels of land are identified in the *Installation-Wide Habitat Management Plan for Former Fort, California* (HMP) as containing habitat occupied or potentially occupied by several sensitive wildlife and plant species, some of which are listed or proposed for listing as threatened or endangered under the federal Endangered Species Act. Accordingly, this land is categorized as “Development with Reserve Areas or Development with Restrictions” in the HMP. While the land may be developed, there are specific restrictions to protect biological resources as identified in the HMP and the quitclaim deeds associated with the land.

The quitclaim deeds for land within 1,000 feet of the OU2 Landfills also include a notification stating landowners should refer to 27CCR Section 21190, which identifies protective measures for structures built on or within 1,000 feet of a landfill.

### **3.1.7 Physiography and Topography**

Elevations at Fort Ord range from approximately sea level at the beach to 900 feet mean sea level (MSL) at Wildcat Ridge. At the OU2 Landfills, elevations range from approximately 160 feet MSL at the west end of Area B to 255 feet MSL at the top of the Area E ridgeline. Runoff is minimal due to the high rate

of surface water infiltration into the permeable dune sand; consequently, well-developed natural drainages are absent throughout much of this area. However, erosion has been observed primarily where roads were cut into slopes. In these areas, small gullies are present, but generally end shortly after the topography flattens out. Closed drainage depressions typical of dune topography are common.

### **3.1.8 Geology and Hydrogeology**

Remedial investigation at the OU2 Landfills indicated that the landfill materials were buried in relatively uniform sand dune deposits in shallow trenches approximately 30 feet wide, 10 to 15 feet apart, and extending from ground surface to 10 to 30 feet below ground surface (bgs). Soil samples collected below the OU2 Landfills do not contain chemicals associated with the Landfills; however, chemicals associated with landfilled materials have been detected in soil vapor samples obtained from soil overlying the Landfills and in the groundwater collected from beneath the Landfills. The chemicals are believed to have migrated away from the landfilled materials as vapors or as solutes in leachate (Army, 1995).

Groundwater in the uppermost A-Aquifer in the area of the OU2 Landfills generally flows northwest toward the Monterey Bay; however, groundwater east of the OU2 Landfills generally flows northeast toward the Salinas River due to a groundwater divide located east of Area F. Due to extensive local and regional pumping of water from the Upper and Lower 180-Foot Aquifers for agricultural and domestic use, the natural westward flow of groundwater is reversed to the east toward the Salinas Valley. The Upper 180-Foot Aquifer is separated from the A-Aquifer by a relatively impermeable clay layer known as the Salinas Valley Aquitard; however, near the Monterey Bay, these two aquifers are connected because the aquitard pinches out in this area. Therefore, chemicals of concern (COCs) in the A-Aquifer have the potential to migrate into the Upper 180-Foot Aquifer (Army, 1995).

### 3.2 Worksheet #11: Project/Data Quality Objectives

Data quality objectives (DQOs) are qualitative and quantitative statements that outline the decision-making process and specify the data required to support corrective actions. DQOs specify the level of uncertainty that will be accepted in results derived from data. The DQO process used for developing data quality criteria and performance specifications for decision-making is consistent with the *Guidance on Systematic Planning Using the Data Quality Objectives Process*, EPA QA/G-4 (EPA, 2006). The DQO process consists of the following seven steps:

- Step 1: State the problem
- Step 2: Identify the goals of the study
- Step 3: Identify information inputs
- Step 4: Define the boundaries of the study
- Step 5: Develop the analytical approach
- Step 6: Specify performance or acceptance criteria
- Step 7: Develop the plan for obtaining data

There are DQOs for the three types of testing at the OU2 Landfills: (1) TTU source testing, (2) TTU operational influent LFG testing, and (3) LFG monitoring at the Landfills perimeter.

#### 3.2.1 DQO #1: TTU Source Testing

**Problem Statement.** Even though the Air District does not have jurisdiction over the TTU and the exhaust stack, the Army will perform annual source testing of the TTU to determine whether it operates efficiently and meets local regulatory standards. The optimum operating conditions, based on permits issued for similar facilities for the type of TTU at the OU2 Landfills, are:

- Minimum destruction efficiency of total hydrocarbons (THC) shall be 98% by weight, or reduction of the outlet non-methane organic compounds (NMOC) concentration to less than 20 parts per million by volume (ppmv), dry basis as hexane, at 3% oxygen (O<sub>2</sub>).
- Minimum destruction efficiency of methane shall be 99% by weight.
- Combustion temperature shall be maintained at a minimum of 1,400 °F within 30 minutes of any startup; minimum combustion residence time shall be 0.6 seconds.
- Instrumentation shall record combustion temperature continuously during operation.
- Nitrogen oxide (NO) emissions shall not exceed 0.06 pounds per million British thermal units (lb/MMBtu).
- Carbon monoxide (CO) emissions shall not exceed 0.18 lb/MMBtu.
- THC emissions shall not exceed 0.03 lb/MMBtu.
- Sulfur dioxide (SO<sub>2</sub>) emissions shall not exceed 0.2% by volume (%v; 2,000 ppmv).
- Inlet sulfur content shall not exceed 50 grains hydrogen sulfide per 100 cubic feet of gas.
- Instrumentation shall continuously record the amount of LFG flow to the flare during operation.
- No air contaminant which is as dark as or darker than Ringlemann 1 or equivalent (20% opacity) shall be discharged for more than an aggregate 3 minutes in any hour.
- No emission shall constitute a public nuisance.



Influent LFG and exhaust emission concentrations and flow rates (measured under maximum available throughput loads) will be used to calculate the mass emission rates of LFG constituents and the mass emission factors for secondary pollutants that result from the combustion process.

**Study goals.** The goals of the study are to determine whether the TTU operates efficiently under current operating conditions and meets local regulatory standards. The system may require adjustments to increase its efficiency and/or to achieve the target operating conditions.

**Information inputs.** To meet the goals of the study, the following inputs will be required:

Stack Emissions (Effluent)

- Gas stream volumetric flow rate
- Nitrogen oxides (NO<sub>x</sub>), CO, O<sub>2</sub>, carbon dioxide (CO<sub>2</sub>)
- NMOCs/THC
- SO<sub>2</sub> (calculated)
- Methane (CH<sub>4</sub>)
- VOCs listed in Worksheet #15 (Section 3.6.3)
- Flare temperature

Influent LFG

- Heating value (calculated based on hydrocarbon content; caloric content of gas)
- O<sub>2</sub>, CO<sub>2</sub>, nitrogen (N<sub>2</sub>)
- CH<sub>4</sub>
- VOCs listed in Worksheet #15 (Section 3.6.3)
- NMOCs
- Reduced sulfur compounds
- LFG flow rate

A certified mobile laboratory provided and staffed by Best Environmental will be on site to measure the above parameters (with the exception of VOCs, fixed gases, and reduced sulfur compounds, which will be analyzed in a certified fixed laboratory). Best Environmental is certified by the State of California Air Resources Board to conduct compliance testing pursuant to California Code of Regulations, Title 17, Section 91207. Section 6.0 provides details of the analytical methods to be employed. The LFG flow rate and flare temperature will be measured using a calibrated flow meter and thermocouple on site.

Sample data from stack emissions and influent LFG testing, in combination with gas flow rates and other parameters, will be used to perform calculations to determine whether the TTU achieves the optimum operating conditions.

**Study boundaries.** Emission samples will be collected from two sampling ports on the TTU stack. The sampling ports are in the same horizontal cross-section of the stack but are 90 degrees apart. Influent LFG samples will be collected from a sampling port located before the TTU.

**Analytical approach.** TTU stack emissions and the influent LFG concentrations for specific gases are measured to determine the TTU's efficiency, its ability to achieve optimum operating conditions, and its ability to meet regulatory standards.

- If mathematical calculations and direct measurement data obtained from stack emissions and influent LFG testing demonstrate that it meets the target operating conditions, then the TTU will be considered to be operating efficiently.
- If mathematical calculations and direct measurement data obtained from stack emissions and operational influent LFG testing do not demonstrate that it meets the target operating conditions, then the TTU may require adjustments to increase its efficiency and meet target operating conditions.
- If stack emission data show that the system does not achieve regulatory standards, then the TTU may require optimization or upgrading to achieve the regulatory standards.
- If stack emission data show that the system meets regulatory standards, then the TTU will not require further optimization.
- If a VOC has not been detected in any of the samples associated with the LFG extraction system (TTU influent, extraction legs, stack) for five consecutive annual monitoring events, the VOC will be removed from the TO-15 target analyte list (Worksheet #15) for operational extraction system sampling only.
- The eleven VOCs identified as COCs for groundwater in the OU2 Landfills ROD will remain on the TO-15 target analyte list, regardless of whether they have been non-detect for five consecutive annual monitoring events.
- If the list of VOCs identified as COCs for groundwater is revised in a subsequent OU2 decision document, then the most current list of COCs for groundwater will remain on the TO-15 target analyte list.
- To confirm compliance with regulatory standards, the full TO-15 list of VOCs will be reported once every 5 years<sup>2</sup> for samples associated with the TTU system. If a VOC that was previously removed from the TO-15 target analyte list for DQO #1 is detected, this VOC will be added to the TO-15 target analyte list for DQO #1 (Worksheet #15).
- These criteria are applied retroactively as part of a previous QAPP revision to include VOC analytical data collected since TTU operations began in April 2006 (Ahtna, 2016a).

**Performance or acceptance criteria.** Decisions could be affected adversely by errors in field and/or fixed laboratory measurements. By adhering to standard procedures, and approved methods to obtain the most reliable data, decision errors will be minimized and should not be a factor in making decisions.

**Plan for obtaining data.** The TTU should be operated and maintained properly to achieve continuous optimum performance and efficiency per the requirements of the O&M Plan (Shaw, 2008a). The field

---

<sup>2</sup> The full TO-15 list of VOCs was last reported in the *Final Annual Report, 2015, Operations and Maintenance, Operable Unit 2 Landfills, Former Fort Ord, California* (2015 Annual Report, Administrative Record No. OU2-703) and will next be reported in the 2019 Annual Report. The full TO-15 list of certified compounds is provided in Attachment B, Analytical Laboratory Information.

test methods, parameters, numbers of tests, durations of tests for stack emission testing, and information inputs for effluent LFG are:

Sample Parameter	Test Method	Number of Runs/Samples	Test Duration	Information Input Source
Flow Rate	EPA Method 19	3	40 minutes	Mobile Laboratory
O <sub>2</sub> , CO <sub>2</sub>	EPA Method 3A	3	40 minutes	Mobile Laboratory
CH <sub>4</sub> /NMOC/THC	EPA Method 25A	3	40 minutes	Mobile Laboratory
CO	EPA Method 10	3	40 minutes	Mobile Laboratory
NO <sub>x</sub>	EPA Method 7E	3	40 minutes	Mobile Laboratory
VOCs	EPA Method TO-15	1	NA	Fixed Laboratory

Access to the stack will be through a shared sample line provided by the source testing contractor. For all sample parameters except VOCs, a heated and filtered stainless steel probe will be used to extract the gas sample from the stack. A heated, 3/8-inch Teflon<sup>®</sup> line will transport the sample from the point of extraction to the non-contact gas conditioning chiller system. The gas conditioning system and all analytical equipment will be provided by the source testing contractor in a self-contained mobile test laboratory. The moisture will be condensed and removed from the gas stream, while the pollutants pass through to the analytical equipment. The analyzer will be located in a temperature-controlled area to minimize thermal effects on the calibration of the instrument used in taking the measurements. For VOCs, the sample is collected at the sample port on the stack, using a vacuum pump and Tedlar<sup>™</sup> bag, and shipped to the fixed laboratory (Eurofins) for analysis.

The laboratory test methods, parameters, numbers of tests, and information inputs for influent LFG are as follows:

Sample Parameter	Test Method	Number of Samples	Information Input Source
Heating Value (calculated), O <sub>2</sub> , CO <sub>2</sub> , NMOC	ASTM D1945	1	Fixed Laboratory
VOCs	EPA Method TO-15	1	Fixed Laboratory
Total Reduced Sulfurs	ASTM D5504	1	Fixed Laboratory
LFG rate	Field measurement	Continuous	Flow meter
Flare temperature	Field measurement	Continuous	Thermocouple

Source testing will be performed annually to demonstrate that the TTU is operating within the substantive requirements of Air District emission limits.

### 3.2.2 DQO #2: Operational Influent LFG Testing

**Problem Statement.** The composition and concentration of the operation influent gas stream need to be known in order to operate the TTU efficiently and to establish a schedule of treatment and extraction operations. The composition and characteristics from operational EWs need to be monitored to maintain compliance with 5%v standard at the property boundary. VOC mass extraction rates may need to be adjusted to maximize removal.

**Study goals.** The principal study goals are to determine the operational influent LFG composition and characteristics so that methane concentrations can be maintained below the lower explosive limit of 5%v, and to determine the composition and characteristics of operational EWs and other wells and probes to prevent adverse acute and chronic exposure to toxic and/or carcinogenic compounds.

**Information inputs.** To determine trends in composition and characteristics present in the TTU operational influent LFG and the EWs, the following inputs are required using a portable LFG analyzer:

Influent LFG

CH<sub>4</sub>

CO<sub>2</sub>

O<sub>2</sub>

Balance gas (a combination of the remainder of gases, but the majority is N<sub>2</sub>)

Temperature

Flow

Vacuum

Input will also come from the analysis by EPA Method TO-15 at a fixed-base laboratory for the list of VOCs provided in Worksheet #15 (Section 3.6.3).

**Study boundaries.** The boundaries of the study are the frequency and the locations of monitoring points for the TTU and the compliance perimeter probes and EWs on the Eastern side of Area F, where the OU2 Landfills are closest to a residential housing area.

**Analytical approach.** The composition of gases from the operational EWs and perimeter probes will be monitored.

- If the concentration of methane is below 40%v, and the flow rate is below 30 standard cubic feet per minute (scfm), or if methane is below 30%v and the flow rate is below 50 scfm as measured in the influent LFG, then the system parameters will be adjusted (e.g., EW flow rates may be adjusted, the TTU may be shut down and operated intermittently, or supplemental fuel may be added to operate the TTU continuously).
- If the concentration of methane is greater than 50%v, and the flow rate is 180 scfm or greater, or if the concentration of methane is greater than 30%v, and the flow rate is 300 scfm or greater, resulting in maximum influent conditions greater than 5 million Btu per hour (Btu/hr), then the system may be adjusted or shut down.
- If the methane concentrations exhibit a downward trend, possibly due to short-term over-extraction of the available LFG, then the TTU may be operated intermittently, or shut down, or fuel may be added to avoid permanently damaging the methane-generating potential of the waste and substantially reducing the long-term availability of fuel for self-sustaining TTU operations.
- If methane concentrations in the compliance perimeter monitoring probes associated with the eastern perimeter leg are greater than the regulatory compliance concentration of 5%v, then the eastern perimeter leg will be operated more frequently to maintain compliance.
- If methane concentrations in the eastern perimeter probes are below 5%v, then this leg may be shut down.

- If methane concentrations in the northern or southern perimeter leg are less than 10%v, then these leg(s) may be shut down.
- If methane concentrations in individual interior EWs at Area F are below 40%v, then the individual wells may be shut down.
- If methane concentrations in individual interior EWs at Area D are below 30%v, then the individual wells may be shut down.
- If methane concentrations in the interior legs of Area D or Area F are below 50%v, then operation of the TTU will be intermittent rather than continuous.
- If EW temperatures are greater than 120 °F, then the individual well(s) or the leg will be shut down.
- If a VOC has not been detected in any of the samples collected from the LFG extraction system for five consecutive annual monitoring events, the VOC will be removed from the TO-15 target analyte list (Worksheet #15) for LFG extraction system sampling only.
- The eleven VOCs identified as COCs for groundwater in the OU2 Landfills ROD will remain on the TO-15 target analyte list, regardless of whether they have been non-detect for five consecutive annual monitoring events.
- If the list of VOCs identified as COCs for groundwater is revised in a subsequent OU2 decision document, then the most current list of COCs for groundwater will remain on the TO-15 target analyte list.
- The full TO-15 list of VOCs will be reported once every 5 years<sup>3</sup> for samples associated with the operational LFG extraction legs. If a VOC that was previously removed from the TO-15 target analyte list for DQO #2 is detected, this VOC will be added to the TO-15 target analyte list for DQO #2 (Worksheet #15).
- These criteria will be applied retroactively as part of a previous QAPP revision to include VOC analytical data collected since TTU operations began in April 2006 (Ahtna 2016a).

**Performance or acceptance criteria.** Decisions could be affected adversely by errors in field and/or fixed laboratory measurements. By adhering to standard procedures and approved methods to obtain the most reliable data, decision errors will be minimized and should not be a factor in making decisions.

**Plan for obtaining data.** The TTU should be operated and maintained properly to achieve continuous optimum performance and efficiency. As required, field measurements will be performed using a portable LFG analyzer.

---

<sup>3</sup> The full TO-15 list of VOCs was last reported in the 2015 Annual Report (Administrative Record No. OU2-703) and will next be reported in the 2019 Annual Report. The full TO-15 list of certified compounds is provided in Attachment B, Analytical Laboratory Information.

Sample Parameter	Location	Test Method	Frequency
CH <sub>4</sub> , O <sub>2</sub> , CO <sub>2</sub> , balance gas, temperature, flow rate, vacuum	Interior Extraction Legs, and points (wells and vents) in operation	Portable LFG analyzer	Biweekly or when system is in operation
	Influent	Portable LFG analyzer	Biweekly or when system is in operation
VOCs	Influent	EPA Method TO-15	Annual (during source testing)
VOCs	Interior Extraction Legs	EPA Method TO-15	Annual

### 3.2.3 DQO #3: Compliance Perimeter Probes

**Problem statement.** To provide for the protection of public health and safety and the environment, methane concentrations will not exceed 5%v at the landfill perimeter and trace gases will be controlled to prevent adverse acute and chronic exposure to toxic and/or carcinogenic compounds.<sup>4</sup> Methane and VOCs are measured to determine whether concentrations are in compliance with the regulatory requirements or whether corrective actions need to be implemented.

**Goals of the study.** The primary decision is whether the concentrations of methane in the compliance perimeter probes meet the regulatory requirement. The secondary decision is whether the trace gas concentrations are at a level where they need to be controlled. The alternative actions that could result from these decisions are:

- Methane concentrations along the perimeter of the landfill do not exceed regulatory requirements, and no corrective actions are required, or methane concentrations along the perimeter of the landfill exceed the regulatory requirements and corrective actions need to be implemented.
- Methane concentrations along the eastern perimeter of Area F, where residential housing is located closest to the OU2 Landfills, are below 5%v and LFG migration is being controlled by operations of the TTU; or methane concentrations along the eastern perimeter of Area F are above 5%v and LFG migration is not being controlled by operations of the TTU and the operational schedule of the TTU needs to be modified.
- Trace gases need to be controlled to prevent adverse acute and chronic exposure to toxic and/or carcinogenic compounds, or trace gases do not need to be controlled.

**Identify information inputs.** To resolve the decision statement, methane and VOC concentrations will be measured at the compliance perimeter probes.

Twenty-one compliance perimeter probes will be sampled annually for VOCs. Samples will be analyzed using EPA Method TO-15 for the list of VOCs provided in Worksheet #15 (Section 3.6.4). Results will be compared to historical ranges.

Compliance perimeter probes will be monitored quarterly for methane. A portable LFG analyzer will be used in the field to measure CH<sub>4</sub>, O<sub>2</sub>, CO<sub>2</sub>, and balance gas.

<sup>4</sup> For the purposes of this QAPP, "trace gases" means VOCs.

**Study boundaries.** To determine the concentrations of methane and trace gases compliance perimeter probes installed along the perimeter of the OU2 Landfills will be monitored.

**Analytical approach.** The parameters of interest are the concentrations of the methane and trace gases at the OU2 Landfills perimeter. Compliance perimeter probes (Figure 2) will be monitored quarterly for methane and annually for VOCs.

The following decision rules apply to methane in the compliance perimeter probes:

- If the concentration of methane is less than 5%v, then there is no LFG migration and the OU2 Landfills are in compliance with the regulatory requirements.
- If the concentration of methane is greater than 5%v, then there is a potential for LFG migration, and corrective actions need to be implemented.
- If methane concentrations along the eastern perimeter of Area F, where residential housing is located closest to the OU2 Landfills, are less than 5%v, then LFG migration is being controlled by operations of the TTU.
- If methane concentrations along the eastern perimeter of Area F, where residential housing is located closest to the OU2 Landfills, are greater than 5%v, then LFG migration is not being controlled by operations of the TTU and the operational schedule of the TTU needs to be modified.

The following decision rules relate to VOCs and are based on comparison of current analytical data with historical data since startup of the pilot LFG extraction and treatment system:

- For compliance perimeter probes with previous measured detections greater than 1,000 times the most current DTSC residential air screening level (DTSC-SL) for vinyl chloride (1,000 times the DTSC-SL equals 9.5 micrograms per cubic meter ( $\mu\text{g}/\text{m}^3$ ) or 3.7 parts per billion by volume (ppbv) based on the current DTSC-SL (DTSC, 2019)), if the concentration of vinyl chloride exceeds the previous maximum recorded value, the probe will be sampled quarterly until two successive measurements show declining or constant concentrations.
- For compliance perimeter probes with previous measured detections greater than 1,000 times the most current DTSC-SL for tetrachloroethene (PCE) (1,000 times the DTSC-SL equals 460  $\mu\text{g}/\text{m}^3$  or 67.8 ppbv based on the current DTSC-SL (DTSC, 2019)), if the concentration of PCE exceeds the previous maximum recorded value, the probe will be sampled quarterly until two successive measurements show declining or constant concentrations.
- For compliance perimeter probes with previous measured detections greater than 100 times the most current EPA Residential Ambient Air Regional Screening Level (EPA-RSL) for chloroform (100 times the EPA-RSL equals 12  $\mu\text{g}/\text{m}^3$  or 2.5 ppbv based on the current EPA-RSL (EPA, 2019)): if the concentration of chloroform exceeds the previous maximum recorded value, the probe will be sampled quarterly until two successive measurements show declining or constant concentrations.
- For compliance perimeter probes with no previous measured detections greater than 1,000 times the most current DTSC-SL for vinyl chloride or PCE in gas: if the concentration remains less than 1,000 times the DTSC-SL, then no action is required.
- For compliance perimeter probes with no previous measured detections greater than 100 times

the most current EPA-RSL for chloroform in gas: if the concentration remains less than 100 times the EPA-RSL, then no action is required.

- For compliance perimeter probes with no previous measured detections greater than 1,000 times the most current DTSC-SL for vinyl chloride or PCE in gas: if the concentration exceeds 1,000 times the DTSC-SL, then the probe will be sampled quarterly until two successive measurements show declining or constant concentrations.
- For compliance perimeter probes with no previous measured detections greater than 100 times the most current EPA-RSL for chloroform in gas: if the concentration exceeds 100 times the EPA-RSL, then the probe will be sampled quarterly until two successive measurements show declining or constant concentrations.
- If a VOC has not been detected in any of the samples collected from compliance perimeter probes for five consecutive annual monitoring events, the VOC will be removed from the TO-15 target analyte list (Worksheet #15) for compliance perimeter probes only.
- The eleven VOCs identified as COCs for groundwater in the OU2 Landfills ROD will remain on the TO-15 target analyte list, regardless of whether they have been non-detect for five consecutive annual monitoring events.
- If the list of VOCs identified as COCs for groundwater is revised in a subsequent OU2 decision document, then the most current list of COCs for groundwater will remain on the TO-15 target analyte list.
- To confirm compliance with regulatory standards, the full TO-15 list of VOCs will be reported once every 5 years<sup>5</sup> for samples collected from compliance perimeter probes. If a VOC that was previously removed from the TO-15 target analyte list for DQO #3 is detected, this VOC will be added to the TO-15 target analyte list for DQO #3 (Worksheet #15).
- These criteria will be applied retroactively as part of a previous QAPP revision to include VOC analytical data collected since TTU operations began in April 2006 (Ahtna, 2016a).

**Performance or acceptance criteria.** Decisions could be affected adversely by errors in field and/or fixed laboratory measurements. By adhering to standard procedures and approved methods to obtain the most reliable data, decision errors will be minimized and should not be a factor in making decisions.

**Plan for obtaining data.** The compliance perimeter probes were installed at approximately 1,000 feet apart at the perimeter of the OU2 Landfills.

### 3.2.4 DQO #4: Monitoring Probes and Vents

**Problem statement.** To provide for the protection of public health and safety and the environment, methane concentrations will not exceed 5%v at the landfill perimeter and trace gases will be controlled to prevent adverse acute and chronic exposure to toxic and/or carcinogenic compounds. Methane needs to be measured at monitoring probes and vents to provide additional data to ensure compliance with the regulatory requirements and to determine whether corrective actions need to be implemented.

---

<sup>5</sup> The full TO-15 list of VOCs was last reported in the 2015 Annual Report (Administrative Record No. OU2-703) and will next be reported in the 2019 Annual Report.



**Goals of the study.** The primary decision is whether methane concentrations are exhibiting upward trends in the monitoring probes or landfill vents. The alternative actions that could result from these decisions are:

- Methane concentrations in the compliance perimeter probes adjacent to monitoring locations may be negatively impacted by increasing methane concentrations monitored in perimeter monitoring probes and landfill vents and corrective actions need to be implemented.
- Methane concentrations along the eastern perimeter of Area F, where residential housing is located closest to the OU2 Landfills, are below 5%v and LFG migration is being controlled by operations of the TTU; or methane concentrations along the eastern perimeter of Area F are above 5%v and LFG migration is not being controlled by operations of the TTU and the operational schedule of the TTU needs to be modified.

**Identify information inputs.** To resolve the decision statement, methane concentrations will be measured at the perimeter monitoring probes and landfill vents.

Forty-six monitoring probes will be sampled quarterly for methane. In addition to the monitoring probes, two shallow probes installed in the utility trench located within the OU2 Landfills also will be monitored. The 12 passive vents installed along the center ridgeline of each landfill area also will be monitored. Methane concentrations in all passive vents consistently are above 5%v; however, there is no regulatory standard for methane concentration in passive vents, nor are there any regulatory actions for methane concentrations exceeding 5%v in passive vents in solid waste landfills. Vents are not intended to be representative sampling locations for LFG conditions in the waste, and monitoring results are used as only a non-quantitative indicator of trends in LFG accumulation in the foundation cover soils. A portable LFG analyzer will be used in the field to measure CH<sub>4</sub>, O<sub>2</sub>, CO<sub>2</sub>, and balance gas.

Additional investigations, such as the installation of permanent or temporary probes, may be conducted to measure methane and/or VOCs. Additional investigations may be prepared and implemented as an amendment to this QAPP or as a separate plan.

**Study boundaries.** To determine any upward methane trends, monitoring probes and vents at OU2 Landfills will be monitored.

**Analytical approach.** The parameters of interest are the concentrations of the methane at the OU2 Landfills.

The following decision rules apply to methane in the perimeter probes:

- If the concentration of methane is greater than 5%v, an upward trend in concentration is observed, then there is a potential for LFG migration, and corrective actions need to be implemented.
- If methane concentrations along the eastern perimeter of Area F, where residential housing is located closest to the OU2 Landfills, are less than 5%v, then LFG migration is being controlled by operations of the TTU.
- If methane concentrations along the eastern perimeter of Area F, where residential housing is located closest to the OU2 Landfills, are greater than 5%v, then LFG migration is not being

controlled by operations of the TTU and the operational schedule of the TTU needs to be modified.

The following decision rules apply to monitoring frequency of the perimeter probes:

- Probes designated as Additional LFG Monitoring Probes (Figure 2) will be monitored quarterly for methane except:
  - If methane concentrations in the probe are less than 1%v for 20 consecutive quarterly monitoring events, then the probe will be moved to an annual monitoring schedule.
  - If methane concentrations in the probe are less than 1%v for five consecutive annual monitoring events, then the probe will be removed from the monitoring program.

These decision rules will be applied retroactively as part of a previous QAPP revision to include methane concentration data collected since TTU operations began in April 2006 (Ahtna, 2016a).

- If the TTU is unintentionally nonoperational for technical reasons or other unforeseen circumstances for more than 2 months, additional LFG Monitoring Probes in Area F that are on an annual monitoring schedule will be monitored for methane concentrations in the next quarterly monitoring event. Additional probes may be added to the monitoring program depending upon the results of the additional annual probes added. This data will be used to determine TTU operational parameters when the TTU is online again.

The following decision rules apply to methane in the utility trench probes:

- If the concentration of methane is less than 5%v, then there is no potential for LFG migration via the utility trench and the OU2 Landfills are in compliance with the regulatory requirements.
- If the concentration of methane is greater than 5%v, then there is a potential for LFG migration via the utility trench and corrective actions need to be implemented.

**Performance or acceptance criteria.** Decisions could be affected adversely by errors in field measurements. By adhering to standard procedures and approved methods to obtain the most reliable data, decision errors will be minimized and should not be a factor in making decisions.

**Plan for obtaining data.** The probes along the northern and eastern perimeters of Area F, which are closer to residential areas, are spaced a maximum of 500 feet apart due to the landfill proximity to the housing area. Additional investigations, such as the installation of permanent or temporary perimeter probes or ambient air monitoring, also may be conducted to characterize methane and trace gas concentrations.

### 3.3 Worksheet #12: Measurement Performance Criteria

The following sections provide measurement performance criteria for the fixed laboratory methods. For measurement performance criteria for the mobile laboratory continuous sampling EPA Methods 3A, 7E, 10 and 25A, refer to the method documentation.

#### 3.3.1 Analytical Group/Method: Fixed Gases/ASTM D1945

Estimated Concentration Level: Low

Matrix: Gas (ppmv)

Data Quality Indicators (DQIs)	QC Sample or Measurement Performance Activity	Measurement Performance Criteria
Precision	Field Duplicates	Relative Percent Difference (RPD) < 30%
Precision	Laboratory Duplicate	RPD < 25%
Accuracy	Laboratory Control Sample	85-115%
Bias/Sensitivity	Method Blanks	< Limit of Quantitation (LOQ) <sup>1</sup>
Completeness	Data Assessment	≥ 90%
Comparability	Data Review: compare results to previous sampling events	Same unit of measure and LOQs are consistent with previously collected data

#### 3.3.2 Analytical Group/Method: Sulfur Gases/ASTM D5504

Estimated Concentration Level: Low

Matrix: Gas (ppbv)

DQIs	QC Sample or Measurement Performance Activity	Measurement Performance Criteria
Precision	Field Duplicates	RPD < 30%
Precision	Laboratory Duplicate	RPD < 25%
Accuracy	Laboratory Control Sample	70-130%
Bias/Sensitivity	Method Blanks	< LOQ <sup>1</sup>
Completeness	Data Assessment	≥ 90%
Comparability	Data Review: compare results to previous sampling events	Same unit of measure and LOQs meet project decision limits (PDLs) <sup>1</sup>

<sup>1</sup>See Worksheet #15 for LOQ values

### 3.3.3 Analytical Group/Method: Volatile Organic Compounds (VOC)/TO-15

Estimated Concentration Level: Low

Matrix: Gas (ppbv)

DQIs	QC Sample or Measurement Performance Activity	Measurement Performance Criteria	
Precision	Field Duplicates	RPD < 30%	
Precision	Laboratory Duplicate	RPD < 25%	
Accuracy	Surrogate	1,2-dichloroethane-d4	50-150 %
		Toluene-d8	50-150 %
		4-Bromofluorobenzene	50-150 %
Accuracy	Laboratory Control Sample (LCS) <sup>1,2</sup>	Benzene	69-119 %
		Carbon Tetrachloride	68-132 %
		Chloroform	68-123 %
		1,1-Dichloroethane	68-126 %
		1,2-Dichloroethane	65-128 %
		cis-1,2-Dichloroethene	70-121%
		1,2-Dichloropropane	69-123%
		Dichloromethane (Methylene chloride)	62-115 %
		Tetrachloroethene	66-124 %
		Trichloroethene	71-123 %
		Vinyl chloride	64-127 %
Bias/Sensitivity	Method Blanks	<LOQ <sup>3</sup> (common laboratory contaminants) and < ½ LOQ (all other compounds)	
Completeness	Data Assessment	≥ 90%	
Comparability	Data Review: compare results to previous sampling events	Same unit of measure and LOQs meet PDLs <sup>3</sup>	

**Analytical Group/Method: Volatile Organic Compounds (VOC)/TO-15 (continued)**

**Notes:**

<sup>1</sup>Samples will be spiked for all compounds on the TO-15 project reporting list(s) (presented in Sections 3.6.3 and 3.6.4); however, only the compounds presented will be controlled per the requirements presented in the table. Compounds presented are those listed as COCs for groundwater in Table 1 of the OU2 Landfills ROD (Army, 1994). VOCs in LFG are not identified as COCs in the OU2 Landfills ROD (Army, 1994); however, ARARs identified in the OU2 Landfills ROD require control of trace gases to prevent adverse acute and chronic exposure to toxic and/or carcinogenic compounds; therefore, the comprehensive project report list(s) of TO-15 analytes are reported to ensure the substantive requirements of these ARARs are met.

<sup>2</sup>The remaining compounds need to meet the following requirements:

- a. Standard compounds: 70 - 130% for at least 90% of the compounds
- b. Non-standard compounds: 60 - 140% for at least 80% of the compounds
- c. Hexachlorobutadiene: 50-150%

<sup>3</sup>See Worksheet #15 for LOQs

### 3.4 Worksheet #13: Secondary Data Uses and Limitations

Secondary data and information that will be used, including originating sources, are identified below. How the secondary data will be used and the limitations on their uses are specified. Data from these documents will be utilized as appropriate.

<b>Data Type</b>	<b>Data Source</b> (originating organization, report title and date)	<b>Data Uses Relative to Current Project</b>	<b>Factors Affecting the Reliability of Data and Limitations on Data Use</b>
Soil Gas, Inspection Reports, Figures, Analytical Data	Gilbane Company Final Annual Report, 2014, Operations and Maintenance, Operable Unit 2 Landfills. July 2015	Trend analysis, design optimization	None
Soil Gas, Inspection Reports, Figures, Analytical Data	Ahtna Final Annual Report, 2015, Operations and Maintenance, Operable Unit 2 Landfills. April 2016	Trend analysis, design optimization	None
Soil Gas, Inspection Reports, Figures, Analytical Data	Ahtna Final Annual Report, 2016, Operations and Maintenance, Operable Unit 2 Landfills. July 2017	Trend analysis, design optimization	None
Soil Gas, Inspection Reports, Figures, Analytical Data	Ahtna Final Annual Report, 2017, Operations and Maintenance, Operable Unit 2 Landfills. May 2018	Trend analysis, design optimization	None
Soil Gas, Inspection Reports, Figures, Analytical Data	Ahtna Final Annual Report, 2018, Operations and Maintenance, Operable Unit 2 Landfills. May 2019	Trend analysis, design optimization	None

### 3.5 Worksheets #14 and #16: Project Tasks and Schedule

Sixty-nine monitoring probes and two utility trench probes are located around Areas B through F (Figure 2). Figure 2 also shows the locations of the probes designated as compliance probes for quarterly methane monitoring and annual VOC monitoring.

Annual monitoring is conducted to collect samples for VOCs for fixed-base laboratory analysis. Annual monitoring generally occurs in the second quarter. Source testing generally is concurrent with the annual VOC sampling.

Activity	Responsible party	Frequency	Deliverable(s)
TTU Monitoring	Ahtna	Biweekly or during TTU operation	Annual Report
Landfill O&M	Ahtna	After major rain events and as needed	Annual Report
TTU Inspection / maintenance	Ahtna	During operation, Quarterly	Annual Report
Landfill methane monitoring	Ahtna	Quarterly	Annual Report
Landfill Inspections	Monterey County Department of Health	Quarterly	Annual Report
Landfill Inspections	Ahtna <sup>2</sup>	Annually	Annual Report
VOC Monitoring	Ahtna	Annually <sup>1</sup>	Annual Report

**Notes:**

<sup>1</sup>The landfill methane monitoring frequency may be decreased to annual or discontinued based on decision rules presented in Worksheet #11, DQO #4.

<sup>1</sup>VOC monitoring frequency may be increased to quarterly based on decision rules presented in Worksheet #11, DQO #3.

<sup>2</sup>The annual landfill inspection will be performed by a California registered professional civil engineer.

### 3.6 Worksheet #15: Laboratory-Specific Detection/Quantitation Limits<sup>1,2</sup>

#### 3.6.1 Analytical Group/Method: Fixed Gases/ASTM D1945

Estimated Concentration Level: Low

Matrix: Gas (%)

CAS Number	Analyte	Laboratory DL	Laboratory LOD	Laboratory LOQ
7782-44-7	Oxygen	0.00430	NA <sup>3</sup>	0.10000
7727-37-9	Nitrogen	0.00570	NA <sup>3</sup>	0.10000
630-08-0	Carbon Monoxide	0.00130	0.00480	0.01000
74-82-8	Methane	0.00003	0.00005	0.00010
124-38-90	Carbon Dioxide	0.00430	0.00480	0.01000
74-84-0	Ethane	0.00004	0.00011	0.00100
74-85-1	Ethene	0.00003	0.00011	0.00100
74-86-2	Acetylene	0.00002	0.00011	0.00100
74-98-6	Propane	0.00003	0.00011	0.00100
75-28-5	Isobutane	0.00003	0.00011	0.00100
106-97-8	Butane	0.00001	0.00011	0.00100
463-82-1	Neopentane	0.00003	0.00011	0.00100
78-78-4	Isopentane	0.00003	0.00011	0.00100
109-66-0	Pentane	0.00003	0.00011	0.00100
C6+	NMOC (C6+)	0.00012	0.00011	0.01000
1333-74-0	Hydrogen	0.00150	0.00620	0.01000

**Notes:**

CAS = Chemical Abstracts Service

LOD = limit of detection

LOQ = limit of quantitation

NMOC = non-methane organic compound (quantified using calibration of hexane and heptane)

<sup>1</sup>Project action limits are not listed in Worksheet #15 because there are no action limits for LFG constituents identified in the OU2 Landfills ROD (Army, 1994); however, these analyses are performed to meet the substantive requirements of ARARs identified in the OU2 Landfills ROD.

<sup>2</sup>The laboratory will report results that are non-detect to the LOQ. Results will be quantified as estimated between the LOD and the LOQ.

<sup>3</sup>LOD analysis requires dilution of the lowest concentration standard, but O<sub>2</sub> and N<sub>2</sub> cannot be reported from a diluted analysis.



### 3.6.2 Analytical Group/Method: Sulfur Gases/ASTM D5504

Estimated Concentration Level: Low

Matrix: Gas (ppbv)

Analyte	CAS Number	DL (ppbV)	LOD (ppbV)	LOQ (ppbV)
Hydrogen Sulfide	7783-06-4	0.95	0.95	3.00
Carbonyl Sulfide / Sulfur Dioxide	463-58-1 / 7446-09-5	0.95	0.95	3.00
Methyl Mercaptan	74-93-1	1.40	1.40	4.50
Ethyl Mercaptan	75-08-1	1.40	1.40	4.50
Dimethyl Sulfide	75-18-3	1.46	1.46	4.70
Carbon Disulfide	75-15-0	2.93	2.93	9.30
Isopropyl Mercaptan	75-33-2	1.40	1.40	4.50
tert-Butyl Mercaptan	75-66-1	1.40	1.40	4.50
n-Propyl Mercaptan	107-03-9	1.40	1.40	4.50
Methylethylsulfide	624-89-5	1.46	1.46	4.70
sec-Butyl Mercaptan / Thiophene	513-53-1 / 110-02-1	0.95	0.95	3.00
iso-Butyl Mercaptan	513-44-0	1.40	1.40	4.50
Diethyl Sulfide	352-93-2	1.46	1.46	4.70
n-Butyl Mercaptan	109-79-5	1.40	1.40	4.50
Dimethyl Disulfide	624-92-0	2.93	2.93	9.30
2-Methylthiophene	554-14-3	0.95	0.95	3.00
3-Methylthiophene	616-44-4	0.95	0.95	3.00
Tetrahydrothiophene	110-01-0	0.95	0.95	3.00
Bromothiophene	1003-09-4	0.95	0.95	3.00
Thiophenol	108-98-5	0.95	0.95	3.00
Diethyl Disulfide	110-81-6	2.93	2.93	9.30

**Notes:**

CAS = Chemical Abstracts Service

LOD = limit of detection

LOQ = limit of quantitation

**3.6.3 Analytical Group/Method: VOC/TO-15 – DQO #1: TTU Source Testing and DQO #2: Operational Influent LFG Testing (see Worksheet #11)**

Estimated Concentration Level: Low

Matrix: Gas (ppbv)

Analyte	CAS Number	Laboratory DL	Laboratory LOD	Laboratory LOQ
1,1-Dichloroethane	75-34-3	0.11	0.40	0.50
1,1-Dichloroethene	75-35-4	0.15	0.25	0.50
1,2,4-Trimethylbenzene	95-63-6	0.060	0.250	0.500
1,2-Dichlorobenzene	95-50-1	0.060	0.250	0.500
1,2-Dichloroethane	107-06-2	0.18	0.25	0.50
1,2-Dichloropropane	78-87-5	0.13	0.25	0.50
1,3,5-Trimethylbenzene	108-67-8	0.060	0.250	0.500
1,3-Dichlorobenzene	541-73-1	0.060	0.250	0.500
1,4-Dichlorobenzene	106-46-7	0.060	0.250	0.500
1,4-Dioxane	123-91-1	0.43	1.00	2.00
2,2,4-Trimethylpentane	540-84-1	0.10	0.50	1.00
2-Butanone <sup>1</sup>	78-93-3	0.47	1.00	2.00
2-Hexanone	591-78-6	0.22	1.00	2.00
2-Propanol	67-63-0	0.29	1.00	2.00
3-Chloropropene	107-05-1	0.38	3.00	4.00
4-Ethyltoluene	622-96-8	0.080	0.250	0.500
4-Methyl-2-pentanone	108-10-1	0.20	0.25	0.50
Acetone <sup>1</sup>	67-64-1	0.80	1.00	5.00
Benzene	71-43-2	0.090	0.250	0.500
Bromomethane	74-83-9	0.33	1.00	5.00
Carbon disulfide	75-15-0	0.30	1.00	2.00
Carbon tetrachloride	56-23-5	0.070	0.250	0.500
Chlorobenzene	108-90-7	0.050	0.250	0.500
Chloroethane	75-00-3	0.24	1.00	2.00
Chloroform	67-66-3	0.070	0.250	0.500
Chloromethane	74-87-3	0.32	1.00	5.00
cis-1,2-Dichloroethene	156-59-2	0.10	0.25	0.50
Cumene	98-82-8	0.050	1.00	2.00
Cyclohexane <sup>1</sup>	110-82-7	0.080	0.250	0.50
Ethanol	64-17-5	0.55	1.00	2.00
Ethyl benzene	100-41-4	0.10	0.25	0.50
Freon 11	75-69-4	0.040	0.250	0.500
Freon 113	76-13-1	0.070	0.250	0.500
Freon 114	76-14-2	0.090	0.250	0.500

Analyte	CAS Number	Laboratory DL	Laboratory LOD	Laboratory LOQ
Freon 12	75-71-8	0.070	0.250	0.500
Heptane	142-82-5	0.13	0.25	0.50
Hexane	110-54-3	0.050	0.250	0.500
m,p-Xylene	108-38-3	0.060	0.250	0.500
Methyl tert-butyl ether	1634-04-4	0.26	0.25	0.50
Methylene chloride <sup>1</sup>	75-09-2	0.34	1.00	5.00
o-Xylene	95-47-6	0.11	0.25	0.50
Propylbenzene	103-65-1	0.040	1.000	2.000
Styrene	100-42-5	0.090	0.250	0.500
Tetrachloroethene	127-18-4	0.060	0.250	0.500
Tetrahydrofuran	109-99-9	0.18	0.25	0.50
Toluene	108-88-3	0.050	0.250	0.500
trans-1,2-Dichloroethene	156-60-5	0.19	0.25	0.50
Trichloroethene	79-01-6	0.050	0.250	0.500
Vinyl chloride	75-01-4	0.10	0.25	0.50

**Notes:**

CAS = Chemical Abstracts Service

LOD = limit of detection

LOQ = limit of quantitation

<sup>1</sup>Common laboratory contaminant

VOCs in LFG are not identified as COCs in the OU2 Landfills ROD (Army, 1994); however, Title 14 CCR Chapter 3, Article 8 (since superseded by 27CCR Chapter 3, Article 6 [Section 20921]) and Air District Rule 207 and Rule 1000 are identified as ARARs. These ARARs require control of trace gases to prevent adverse acute and chronic exposure to toxic and/or carcinogenic compounds; therefore, the full list of TO-15 analytes is reported once every 5 years (next in 2024) to ensure the substantive requirements of these ARARs are met. The list presented contains VOCs that have been consistently detected in samples associated with TTU source testing and operational influent testing (Ahtna, 2016b, 2017, 2018, and 2019). Reduction of VOCs from this list (or addition) is per the analytical approach of DQOs #1 and #2. Accordingly, 1,1,1-Trichloroethane, 1,3-Butadiene, Trans-1,3-dichloropropene, and Bromodichloromethane were removed from the list; 2,2,4-Trimethylpentane, 3-Chloropropene, Cumene, and Propylbenzene were added to the list.

### 3.6.4 Analytical Group/Method: VOC/TO-15 – DQO #3: Compliance Perimeter Probes (see Worksheet #11)

Estimated Concentration Level: Low

Matrix: Gas (ppbv)

Analyte	CAS Number	Laboratory DL	Laboratory LOD	Laboratory LOQ
1,1,1-Trichloroethane	71-55-6	0.070	0.250	0.500
1,1-Dichloroethane	75-34-3	0.11	0.25	0.50
1,2-Dichloroethane	107-06-2	0.18	0.25	0.50
1,2-Dichloropropane	78-87-5	0.13	0.25	0.50
1,4-Dichlorobenzene	106-46-7	0.060	0.250	0.500
1,4-Dioxane	123-91-1	0.43	1.00	2.00
2,2,4-Trimethylpentane	540-84-1	0.10	0.50	1.00
2-Butanone <sup>1</sup>	78-93-3	0.47	1.00	2.00
2-Hexanone	591-78-6	0.22	1.00	2.00
2-Propanol	67-63-0	0.29	1.00	2.00
3-Chloropropene	107-05-1	0.38	3.00	4.00
4-Methyl-2-pentanone	108-10-1	0.20	0.25	0.50
Acetone <sup>1</sup>	67-64-1	0.80	1.00	5.00
Benzene	71-43-2	0.090	0.250	0.500
Bromodichloromethane	75-27-4	0.060	0.250	0.500
Carbon disulfide	75-15-0	0.30	1.00	2.00
Carbon tetrachloride	56-23-5	0.070	0.250	0.500
Chloroethane	75-00-3	0.24	1.00	2.00
Chloroform	67-66-3	0.070	0.250	0.500
Chloromethane	74-87-3	0.32	1.00	5.00
cis-1,2-Dichloroethene	156-59-2	0.10	0.25	0.50
Cumene	98-82-8	0.050	1.00	2.00
Ethanol	64-17-5	0.55	1.00	2.00
Freon 11	75-69-4	0.040	0.250	0.500
Freon 113	76-13-1	0.070	0.250	0.500
Freon 114	76-14-2	0.090	0.250	0.500
Freon 12	75-71-8	0.070	0.250	0.500
Heptane	142-82-5	0.13	0.25	0.50
Hexane	110-54-3	0.050	0.250	0.500
m,p-Xylene	108-38-3	0.060	0.250	0.500
Methylene chloride <sup>1</sup>	75-09-2	0.34	1.00	5.00
Propylbenzene	103-65-1	0.040	1.000	2.000
Tetrachloroethene	127-18-4	0.060	0.250	0.500
Toluene	108-88-3	0.050	0.250	0.500

Analyte	CAS Number	Laboratory DL	Laboratory LOD	Laboratory LOQ
Trichloroethene	79-01-6	0.050	0.250	0.500
Vinyl chloride	75-01-4	0.10	0.25	0.50

**Notes:**

CAS = Chemical Abstracts Service

LOD = limit of detection

LOQ = limit of quantitation

<sup>1</sup>Common laboratory contaminant

VOCs in LFG are not identified as COCs in the OU2 Landfills ROD (Army, 1994); however, Title 14 CCR Chapter 3, Article 8 (since superseded by 27CCR Chapter 3, Article 6 [Section 20921]) and Air District Rule 207 and Rule 1000 are identified as ARARs. These ARARs require control of trace gases to prevent adverse acute and chronic exposure to toxic and/or carcinogenic compounds; therefore, the full list of TO-15 analytes is reported once every 5 years (next in 2024) to ensure the substantive requirements of these ARARs are met. The list presented contains VOCs that have been consistently detected in samples associated with compliance perimeter probe testing. Reduction of VOCs from this list (or addition) is per the analytical approach of DQO #3. Accordingly, 1,2,4-Trimethylbenzene, 1,3,5-Trimethylbenzene, 4-Ethyltoluene, Cyclohexane, Ethyl benzene, and o-Xylene were removed from the list; 2,2,4-Trimethylpentane, 3-Chloropropene, Cumene, and Propylbenzene were added to the list.

### 3.6.5 Mobile Laboratory Analytical Group/Methods – DQO #1: TTU Source Testing (see Worksheet #11)

Matrix: Gas (ppmv)

Analyte	EPA Method	CAS Number	Laboratory LOQ
Carbon monoxide	10	630-08-0	0.5
Nitrogen oxides	7E	10024-97-2/10102-44-0	0.5
Oxygen	3A	7782-44-7	0.25
Carbon dioxide	3A	124-38-9	0.25
Methane/NMOC/THC	25A	Various	1.0

**Notes:**

CAS = Chemical Abstracts Service

LOQ = limit of quantitation

NMOC = non-methane organic compounds

## 4.0 Sample Design

### 4.1 Worksheet #17: Sampling Design and Rationale

The O&M Plan (Shaw, 2008a) provides procedures for monitoring the operation of the TTU, including vents, probes, and EWs. Section 5.0 of the O&M Plan (Shaw, 2008a) describes the perimeter monitoring system that is used to test the operational influent and effluent LFG.

Passive vents were installed at 19 locations to minimize the potential for gas buildup beneath the geomembrane (Figure 2). Five vents (VD-2, VD-3, VF-3, VF-4, and VF-5) were converted to EPs to provide supplemental methane to the TTU. All other vents, with the exception of VE-7 and VE-8, were capped in 2001 to mitigate a potential fire hazard. VE-7 and VE-8 were placed in the vertical expansion portion of Area E and are left open because this is a sealed area of the landfill. The 14 passive vents are not monitored for compliance but are monitored quarterly for methane using a portable LFG analyzer. The vents that were converted to EPs are monitored during TTU operations.

To monitor LFG migration, 46 monitoring, 21 compliance, and 2 utility trench probes are located around Areas B through F. Twenty-one compliance probes were installed at a spacing of approximately 1,000 feet around the property boundary as required by 27CCR. The monitoring probes are used to measure CH<sub>4</sub>, O<sub>2</sub>, CO<sub>2</sub>, and balance gas (collectively termed LFG) at additional points around the OU2 Landfills at depths ranging from 12 to 32 feet bgs. A LANDTEC GEM™5000 instrument is used to measure these parameters. The utility trench probes are 4 feet deep. Samples collected from the 21 compliance probes are sent to an off-site laboratory annually for VOC analysis by EPA Method TO-15.

Two types of testing are conducted for the TTU: source testing and operational influent LFG testing. The primary objective of the source testing is to determine whether the TTU operates efficiently. A certified mobile laboratory conducts the source test, which includes analysis of the TTU influent and effluent for the parameters listed below.

Parameter	Monitoring and Analytical Protocols
NO <sub>x</sub> , CO, O <sub>2</sub> , and CO <sub>2</sub>	EPA Methods 7E, 10, and 3A
Outlet CH <sub>4</sub> /NMOC/THC and Speciated VOCs	EPA Method 25A and TO-15
Inlet NMOC and Speciated VOCs	ASTM D1945 and EPA Method TO-15
Inlet Total Reduced Sulfurs	ASTM D5504
LFG Higher Heating Value and Outlet Volumetric Flow Rate	ASTM D1945 and EPA Method 19

Operational influent LFG testing is used to establish the schedule of operations for optimum operation of the TTU. Operational influent LFG testing also aids in quantifying the amounts of VOCs that are being removed from the OU2 Landfills.

Figure 3 presents the locations of the EWs/vents, the collection system, and the TTU system. Section 3.2 lists the sampling locations and methods.

## 4.2 Worksheet #18: Sampling Locations and Methods

### 4.2.1 Operable Unit 2 Landfills

Area	Probe ID	Matrix	Type	Depth (feet)	Analytical Group	Sampling SOP Reference <sup>1</sup>	Frequency	Rationale
B	SGP-1B	LFG	Sample Port	12	Fixed Gases <sup>2</sup>	1	NA	Monitoring Point DQO#3
B	SGP-2B	LFG	Sample Port	12	Fixed Gases	1	Quarterly	Monitoring Point DQO#3
B	SGP-3B	LFG	Sample Port	12	Fixed Gases	1	Quarterly	Compliance DQO#3
					VOCs	2	Annually – Fixed Lab	
B	SGP-4B	LFG	Sample Port	12	Fixed Gases	1	Quarterly	Compliance DQO#3
					VOCs	2	Annually – Fixed Lab	
B	SGP-5B	LFG	Sample Port	12	Fixed Gases	1	NA	Monitoring Point DQO#3
C	SGP-1C	LFG	Sample Port	12	Fixed Gases	1	NA	Monitoring Point DQO#3
C	SGP-2C	LFG	Sample Port	12	Fixed Gases	1	Quarterly	Compliance DQO#3
					VOC	2	Annually – Fixed Lab	
C	SGP-3C	LFG	Sample Port	12	Fixed Gases	1	Quarterly	Compliance DQO#3
					VOCs	2	Annually – Fixed Lab	



Area	Probe ID	Matrix	Type	Depth (feet)	Analytical Group	Sampling SOP Reference <sup>1</sup>	Frequency	Rationale
D	SGP-1D	LFG	Sample Port	12	Fixed Gases	1	Quarterly	Monitoring Point DQO#3
D	SGP-1D	LFG	Sample Port	22	Fixed Gases	1	Quarterly	Monitoring Point DQO#3
D	SGP-2D	LFG	Sample Port	12	Fixed Gases	1	NA	Monitoring Point DQO#3
D	SGP-2D	LFG	Sample Port	22	Fixed Gases	1	NA	Monitoring Point DQO#3
D	SGP-3D	LFG	Sample Port	12	Fixed Gases	1	Annual	Monitoring Point DQO#3
D	SGP-3D	LFG	Sample Port	22	Fixed Gases	1	Annual	Monitoring Point DQO#3
D	SGP-4D	LFG	Sample Port	12	Fixed Gases	1	Quarterly	Compliance DQO#3
					VOCs	2	Annually – Fixed Lab	
D	SGP-4D	LFG	Sample Port	22	Fixed Gases	1	Quarterly	Compliance DQO#3
					VOCs	2	Annually – Fixed Lab	
D	SGP-5D	LFG	Sample Port	4	Fixed Gases	1	NA	Monitoring Point DQO#3

Area	Probe ID	Matrix	Type	Depth (feet)	Analytical Group	Sampling SOP Reference <sup>1</sup>	Frequency	Rationale
D	SGP-6D	LFG	Sample Port	12	Fixed Gases	1	Quarterly	Compliance DQO#3
					VOCs	2	Annually – Fixed Lab	
D	SGP-6D	LFG	Sample Port	22	Fixed Gases	1	Quarterly	Compliance DQO#3
					VOCs	2	Annually – Fixed Lab	
E	SGP-1E	LFG	Sample Port	12	Fixed Gases	2	Quarterly	Monitoring Point DQO#3
E	SGP-2E	LFG	Sample Port	12	Fixed Gases	1	Quarterly	Monitoring Point DQO#3
E	SGP-3E	LFG	Sample Port	12	Fixed Gases	1	Quarterly	Monitoring Point DQO#3
E	SGP-4E	LFG	Sample Port	12	Fixed Gases	1	Quarterly	Monitoring Point DQO#3
E	SGP-5E	LFG	Sample Port	12	Fixed Gases	1	NA	Monitoring Point DQO#3
E	SGP-6E	LFG	Sample Port	12	Fixed Gases	1	NA	Monitoring Point DQO#3
E	SGP-7E	LFG	Sample Port	12	Fixed Gases	1	Quarterly	Compliance DQO#3
					VOCs	2	Annually – Fixed Lab	

Area	Probe ID	Matrix	Type	Depth (feet)	Analytical Group	Sampling SOP Reference <sup>1</sup>	Frequency	Rationale
E	SGP-8E	LFG	Sample Port	12	Fixed Gases	1	Quarterly	Compliance DQO#3
					VOCs	2	Annually – Fixed Lab	
E	SGP-9E	LFG	Sample Port	12	Fixed Gases	1	Quarterly	Compliance DQO#3
					VOCs	2	Annually – Fixed Lab	
F	SGP-1F	LFG	Sample Port	12	Fixed Gases	1	NA	Monitoring Point DQO#3
F	SGP-1F	LFG	Sample Port	22	Fixed Gases	1	NA	Monitoring Point DQO#3
F	SGP-2F	LFG	Sample Port	12	Fixed Gases	1	NA	Monitoring Point DQO#3
F	SGP-2F	LFG	Sample Port	32	Fixed Gases	1	Quarterly	Monitoring Point DQO#3
F	SGP-3F	LFG	Sample Port	12	Fixed Gases	1	NA	Monitoring Point DQO#3
F	SGP-3F	LFG	Sample Port	32	Fixed Gases	1	NA	Monitoring Point DQO#3
F	SGP-4F	LFG	Sample Port	12	Fixed Gases	1	Quarterly	Monitoring Point DQO#3

Area	Probe ID	Matrix	Type	Depth (feet)	Analytical Group	Sampling SOP Reference <sup>1</sup>	Frequency	Rationale
F	SGP-4F	LFG	Sample Port	32	Fixed Gases	1	NA	Monitoring Point DQO#3
F	SGP-5F	LFG	Sample Port	12	Fixed Gases	1	NA	Monitoring Point DQO#3
F	SGP-5F	LFG	Sample Port	32	Fixed Gases	1	NA	Monitoring Point DQO#3
F	SGP-6F	LFG	Sample Port	12	Fixed Gases	1	NA	Monitoring Point DQO#3
F	SGP-6F	LFG	Sample Port	32	Fixed Gases	1	NA	Monitoring Point DQO#3
F	SGP-7F	LFG	Sample Port	12	Fixed Gases	1	NA	Monitoring Point DQO#3
F	SGP-7F	LFG	Sample Port	32	Fixed Gases	1	NA	Monitoring Point DQO#3
F	SGP-8F	LFG	Sample Port	12	Fixed Gases	1	Quarterly	Compliance DQO#3
					VOCs	2	Annually – Fixed Lab	
F	SGP-8F	LFG	Sample Port	22	Fixed Gases	1	Quarterly	Compliance DQO#3
					VOCs	2	Annually – Fixed Lab	

Area	Probe ID	Matrix	Type	Depth (feet)	Analytical Group	Sampling SOP Reference <sup>1</sup>	Frequency	Rationale
F	SGP-9F	LFG	Sample Port	22	Fixed Gases	1	NA	Monitoring Point DQO#3
F	SGP-10F	LFG	Sample Port	12	Fixed Gases	1	NA	Monitoring Point DQO#3
F	SGP-10F	LFG	Sample Port	22	Fixed Gases	1	NA	Monitoring Point DQO#3
F	SGP-11F	LFG	Sample Port	12	Fixed Gases	1	NA	Monitoring Point DQO#3
F	SGP-11F	LFG	Sample Port	32	Fixed Gases	1	Quarterly	Monitoring Point DQO#3
F	SGP-12F	LFG	Sample Port	32	Fixed Gases	1	NA	Monitoring Point DQO#3
F	SGP-13F	LFG	Sample Port	12	Fixed Gases	1	Quarterly	Compliance DQO#3
					VOCs	2	Annually – Fixed Lab	
F	SGP-13F	LFG	Sample Port	32	Fixed Gases	1	Quarterly	Compliance DQO#3
					VOCs	2	Annually – Fixed Lab	
F	SGP-14F	LFG	Sample Port	12	Fixed Gases	1	NA	Monitoring Point DQO#3

Area	Probe ID	Matrix	Type	Depth (feet)	Analytical Group	Sampling SOP Reference <sup>1</sup>	Frequency	Rationale
F	SGP-14F	LFG	Sample Port	32	Fixed Gases	1	NA	Monitoring Point DQO#3
F	SGP-15F	LFG	Sample Port	12	Fixed Gases	1	Quarterly	Compliance DQO#3
					VOCs	2	Annually – Fixed Lab	
F	SGP-15F	LFG	Sample Port	32	Fixed Gases	1	Quarterly	Compliance DQO#3
					VOCs	2	Annually – Fixed Lab	
F	SGP-16F	LFG	Sample Port	4	Fixed Gases	1	NA	Monitoring Point DQO#3
F	SGP-17F	LFG	Sample Port	12	Fixed Gases	1	Quarterly	Compliance DQO#3
					VOCs	2	Annually – Fixed Lab	
F	SGP-17F	LFG	Sample Port	32	Fixed Gases	1	Quarterly	Compliance DQO#3
					VOCs	2	Annually – Fixed Lab	
F	SGP-18F	LFG	Sample Port	12	Fixed Gases	1	NA	Monitoring Point DQO#3
F	SGP-18F	LFG	Sample Port	32	Fixed Gases	1	NA	Monitoring Point DQO#3
F	SGP-19F	LFG	Sample Port	12	Fixed Gases	1	NA	Monitoring Point DQO#3

Area	Probe ID	Matrix	Type	Depth (feet)	Analytical Group	Sampling SOP Reference <sup>1</sup>	Frequency	Rationale
F	SGP-19F	LFG	Sample Port	22	Fixed Gases	1	NA	Monitoring Point DQO#3
F	SGP-20F	LFG	Sample Port	12	Fixed Gases	1	NA	Monitoring Point DQO#3
F	SGP-20F	LFG	Sample Port	32	Fixed Gases	1	NA	Monitoring Point DQO#3
F	SGP-21F	LFG	Sample Port	12	Fixed Gases	1	NA	Monitoring Point DQO#3
F	SGP-21F	LFG	Sample Port	22	Fixed Gases	1	NA	Monitoring Point DQO#3
F	SGP-22F	LFG	Sample Port	12	Fixed Gases	1	Quarterly	Compliance DQO#3
					VOCs	2	Annually – Fixed Lab	
F	SGP-22F	LFG	Sample Port	32	Fixed Gases	1	Quarterly	Compliance DQO#3
					VOCs	2	Annually – Fixed Lab	

#### 4.2.2 Thermal Treatment Unit/Extraction Points

Area	TTU Location	Matrix	Type	Depth (feet)	Analytical Group	Sampling SOP Reference	Frequency	Rationale
D	VD-3	LFG	Sample Port	6	Fixed Gases	1	Biweekly	System Optimization DQO#2
D	EW-35	LFG	Sample Port	75	Fixed Gases	1	Biweekly	System Optimization DQO#2
D	VD-2	LFG	Sample Port	6	Fixed Gases	1	Biweekly	System Optimization DQO#2
F	VF-3	LFG	Sample Port	6	Fixed Gases	1	Biweekly	System Optimization DQO#2
F	EW-34	LFG	Sample Port	60	Fixed Gases	1	Biweekly	System Optimization DQO#2
F	VF-4	LFG	Sample Port	6	Fixed Gases	1	Biweekly	System Optimization DQO#2
F	EW-33	LFG	Sample Port	70	Fixed Gases	1	Biweekly	System Optimization DQO#2
F	EW-32	LFG	Sample Port	60	Fixed Gases	1	Biweekly	System Optimization DQO#2



Area	TTU Location	Matrix	Type	Depth (feet)	Analytical Group	Sampling SOP Reference	Frequency	Rationale
F	VF-5	LFG	Sample Port	6	Fixed Gases	1	Biweekly	System Optimization DQO#2
F	EW-31	LFG	Sample Port	60	Fixed Gases	1	Biweekly	System Optimization DQO#2
F	EW-30	LFG	Sample Port	60	Fixed Gases	1	Biweekly	System Optimization DQO#2
TTU	Area F Header	LFG	Sample Port	NA	Fixed Gases	1	Biweekly	System Optimization DQO#2
TTU	Mixed	LFG	Sample Port	NA	Fixed Gases	1	Biweekly	Source Test Calculation of quantity of VOCs removed DQO#1
					VOCs Fixed Gases Sulfur	2	Annually – Fixed Lab	
TTU	Stack Outlet	LFG	Sample Port	NA	VOCs	1	Annually – Fixed Lab	Source Test DQO#1
TTU	Area D Vents	LFG	Sample Port	NA	Fixed Gases	1	Biweekly	Trend analysis DQO#2
					VOCs	2	Annually – Fixed Lab	
TTU	Area F EWs	LFG	Sample Port	NA	VOCs	2	Annually – Fixed Lab	Trend analysis DQO#2

Area	TTU Location	Matrix	Type	Depth (feet)	Analytical Group	Sampling SOP Reference	Frequency	Rationale
TTU	Area E Header	LFG	Sample Port	NA	Fixed Gases	1	Biweekly	Trend analysis DQO#2
					VOCs	2	Annually – Fixed Lab	
TTU	Area F Extraction Vents	LFG	Sample Port	NA	VOCs	2	Annually – Fixed Lab	Trend analysis DQO#2

**Notes:**

<sup>1</sup>SOPs are listed on Worksheet #21.

<sup>2</sup>Fixed Gases include CH<sub>4</sub>, CO<sub>2</sub>, O<sub>2</sub>, and balance gas. Barometric pressure data is collected during probe monitoring, and induced vacuum is measured during system monitoring.

The sampling number system that will be employed is as follows: The three-digit area location is followed by the source location or probe identifier, followed by a sequential sample numbering system of up to four numbers for each location. For example, the stack outlet sample at the TTU will be recorded as TTU-FO-XXXX, and SGP-15F-depth will be recorded as OU2GMXXXX; where XXXX is the next four-digit sequential number.

EW = Extraction Well

LFG = landfill gas

NA = not applicable (the probe is no longer monitored per decision criteria presented in Worksheet #11, DQO #3)

OU = operable unit

SGP = soil gas probe

SOP = standard operating procedure

TTU = thermal treatment unit

VB = Passive Vent in Area B

VC = Passive Vent in Area C

VD = Passive Vent in Area D

VE = Passive Vent in Area E

VF = Passive Vent in Area F

## 5.0 Sampling Requirements

### 5.1 Worksheets #19 and #30: Sample Containers, Preservation, and Hold Times

Laboratory: Eurofins

180 Blue Ravine Road, Suite B

Folsom, CA 95630-4719

Telephone: 916-985-1000

Point of Contact: Brian Whittaker

Email: BrianWhittaker@eurofinsus.com

Sample Delivery Method: Courier or Hand Delivery

Analytical Group	Matrix	Analytical Method	Accreditation Expiration <sup>1</sup>	Containers (number, size, and type)	Preservation	Analytical Holding Time	Data Package Turnaround
Fixed Gases	Soil Gas	ASTM D1945	Oregon ELAP: 10-17-19; Certification No: CA30005-011 DoD ELAP: 04-18-18 through 04-27-20; Certificate Number: ADE-1451	Tedlar™ Bag <sup>2</sup>	None	72 hours	21 days
VOCs	Soil Gas	TO-15		6L-stainless steel SUMMA™ Canister	None	30 days	21 days
				Tedlar™ Bag	None	48 - 72 hours	21 days
Sulfur Gases	Soil Gas	ASTM D5504	South Coast Air Quality Management District exp. 11/30/19	Tedlar™ Bag	None	24 hours	21 days

**Notes:**

DoD = Department of Defense

ELAP = Environmental Laboratory Accreditation Program

NELAP = National ELAP

<sup>1</sup> The Oregon ELAP certification satisfies NELAP requirements.

<sup>2</sup> Tedlar™ bags used only during the annual source test.

## 5.2 Worksheet #20: Field Quality Control Summary

Matrix	Analytical Group	Preparation/ Analysis Reference	Approximate Number of Primary Sampling Locations <sup>1</sup>	No. of Field Duplicates	No. of LCSs	No. of Equipment Blanks	Total Number of Analyses
Soil Gas	Fixed Gases	ASTM D1945	1	1	1	NA	2
Soil Gas	VOCs	TO-15	28	3	3	NA	31
Soil Gas	Sulfur Gases	ASTM D5504	1	1	1	NA	2

**Notes:**

<sup>1</sup> Samples collected at different depths at the same location are counted as separate sampling locations or stations.

LCS = laboratory control sample

NA = not applicable

### 5.3 Worksheet #21: Field SOPs/Methods

This worksheet documents specific field procedures and methods that will be implemented for work conducted at the OU2 Landfills. The field SOPs will be readily available to all field personnel responsible for their implementation. The SOPs listed below are included in Attachment A.

SOP Reference Number	Title, Revision, Date	Equipment Type	Modified for Project Work? (Y/N)	Comments
1	GEM™5000 Gas Analyzer and Extraction Monitor, Operation Manual (LANDTEC, 2018)	Portable landfill gas analyzer	N	Includes instrument calibration procedures.
2	Guide to Air Sampling Canister and Bags (Eurofins, 2014)	SUMMA™ Canister or Tedlar™ Bag	N	Methods for sampling soil gas.
3	Field Sampling Procedure Using Summa Canisters with RAVEqc Quick-Connect (QT) Fittings (Eurofins, 2019)	Quick-Connect (QT) Fittings	N	Methods for sampling soil gas
4	DoD Environmental Field Sampling Handbook, Revision 1.0, April 2013, Chapter 3. "Common Sampling Procedures" (DoD, 2013)	NA	N	Includes sample documentation, packaging, shipping, and chain of custody requirements.

NA = not applicable

## 5.4 Worksheet #22: Field Equipment Calibration, Maintenance, Testing, and Inspection

Field Instrument specifications for source testing are as follows<sup>1</sup>:

<b>NOx/NO Chemiluminescent Analyzer – Ecophysics Model 70E</b>	
Zero drift	Negligible after 30-minute warm up
Linearity	±1% of full scale
Accuracy	±1% of full scale
Output	0-10 V
Range	0-50, 100 ppmv
<b>O<sub>2</sub> Analyzer, Fuel Type – Teledyne Model 326A</b>	
Accuracy	±1% of scale at constant temperature or ±1% of scale at ±5% of reading, whichever is greater, over the operating temperature range
Output	0-1 V
Range	0-10, 25%
<b>CO Infrared Analyzer – Horiba Model VIA 510</b>	
Zero drift	±1%
Span drift	±1%
Linearity	±1%
Output	0-1 V
Range	0-100 ppmv
<b>THC FID Analyzer – TECO Model 51</b>	
Zero drift	±1%
Span drift	±1%
Linearity	±1%
Output	0-10 V
Range	0-50 ppmv

**Notes:**

<sup>1</sup> See SOP ST-1, Source Test Protocol (Attachment B) for mobile laboratory equipment calibration, maintenance, testing, and inspection procedures.

Field Equipment <sup>1</sup>	Activity	SOP/ Method Reference	Responsible Person	Frequency	Acceptance Criteria	Corrective Action
Gas Analyzer	Calibration	Operations Manual	Field Team Lead (FTL)	Daily during use	Manufacturer's Specifications	Adjust instrument
Infrared Oxygen Analyzer	Calibration	EPA Method 3A		Daily during use prior to and after completion of analytical batch	2% of span	
	Bias Check				5% of span	
	Response time check				< 2 minutes	
Flame ionization detector	Calibration	EPA Method 25A		Daily, prior to and after completion of analytical batch	5% of span	
	Drift Test				3% of span	
Nondispersive infrared sensor CO analyzer	Calibration	EPA Method 10		Daily, prior to and after completion of analytical batch	2% of span	
	Calibration error check				3% of span	
	Bias Check				5% of span	
	Response time check				< 2 minutes	
Chemiluminescent Analyzer	Calibration	EPA Method 7E			2% of span	
	Bias Check				5% of span	
	Response time check				< 2 minutes	

**Notes:**

<sup>1</sup> See SOP ST-1, Source Test Protocol (Attachment B) for mobile laboratory equipment calibration, maintenance, testing, and inspection procedures.

## 6.0 Analytical Requirements

### 6.1 Worksheet #23: Analytical SOPs

The SOPs referenced below are the laboratory-specific procedures for the tests for which the laboratory is certified under DoD ELAP and NELAP (fixed laboratory) and California Air Resources Board (mobile laboratory). Copies of certifications, including the specifically referenced method, are included in Attachment B.

Data will be evaluated based on the guidance provided in the DoD QSM Version 5.3, published methods, and laboratory standard operating procedures.

SOP Reference Number	Title, Revision Date, and / or Number	Definitive or Screening Data	Matrix/ Analytical Group	Equipment Type	Modified for Project Work? (Y/N)
6	Analysis of Volatile Organic Compounds in SUMMA™ Polished Canisters by Modified EPA Methods TO-14A/TO-15, 03/24/15, Revision 737	Definitive	VOCs	Mass Spectrometer	N
54	Analysis of Natural Gases by Modified ASTM D1945 12/8/16, Revision 22	Definitive	Fixed Gases	Gas Chromatograph	N
A.5504.04	SOP, Determination of Sulfur Compounds in Natural Gas and Gaseous Fuels by Gas Chromatography and Chemiluminescence 9/11/2018, Revision 5	Definitive	Sulfur Gases	Sulfur Chemiluminescence Detector	N
ST-1 <sup>1</sup>	Source Test Protocol, Former Fort Ord, Monterey, CA. Thermal Treatment Unit (TTU). June 4, 2018	Definitive	Various	Various	N

**Notes:**

<sup>1</sup>SOPs is for mobile laboratory analysis used during the source test.



## 6.2 Worksheet #24: Analytical Instrument Calibration

Instrument	Calibration Procedure	Calibration Frequency	Acceptance Criteria	Corrective Action	Responsible Person(s)	SOP Reference <sup>1</sup>
Gas Chromatograph (GC)	Initial Calibration (ICAL)	Prior to sample analysis and annually	< 15% Relative Standard Deviation (RSD)	Correct problem, then repeat Initial Calibration.	Laboratory Analyst/Section Manager	54 ASTM D1945
GC	Initial Calibration Verification and Laboratory Control Sample (ICV and LCS)	After each initial calibration and once per analytical batch	85-115% Recovery (%R)	Check the system and reanalyze the standard. Re-prepare the standard if necessary. If the primary standard is found to be in error, re-prepare the primary and calibrate the instrument.	Laboratory Analyst/Section Manager	54 ASTM D1945
GC	Continuing Calibration Verification (CCV)	Daily prior to sample analysis and after every 20 reportable samples	Percent Difference (% D) < 15%	Check the system and reanalyze the standard. Recalibrate the instrument if the criteria cannot be met.	Laboratory Analyst/Section Manager	54 ASTM D1945
GC	ICAL	Prior to sample analysis	A minimum of 5 points (3 points may be accepted to meet sample hold times) RSD ≤ 30%	Evaluate system. Re-prepare and/or reanalyze calibration points.	Laboratory Analyst/Section Manager	A.5504.04 ASTM D5504
GC	ICV	With each ICAL; with each analytical batch	70 - 130% of the expected values for all the compounds	Check the system, re-prepare and/or reanalyze standard. Recalibrate instrument if CCV shows similar recoveries. If recoveries are high and no detections are expected, sample analysis may proceed. If hold time is at risk, flagging and narration of non-compliance may be appropriate.	Laboratory Analyst/Section Manager	A.5504.04 ASTM D5504

Instrument	Calibration Procedure	Calibration Frequency	Acceptance Criteria	Corrective Action	Responsible Person(s)	SOP Reference <sup>1</sup>
GC	CCV	Daily prior to sample analysis	%R: 70 - 130%	Check the system, re-prepare and/or reanalyze standard. Recalibrate instrument if reanalysis shows similar recoveries. If recoveries are high and no detections are expected, sample analysis may proceed. If hold time is at risk, flagging and narration of non-compliance may be appropriate.	Laboratory Analyst/Section Manager	A.5504.04 ASTM D5504

Instrument	Calibration Procedure	Calibration Frequency	Acceptance Criteria	Corrective Action	Responsible Person(s)	SOP Reference <sup>1</sup>
Gas Chromatograph/ Mass Spectrometer (GCMS)	Tuning Criteria	Prior to ICAL and prior to each 12- hour period of sample analysis	TO-15 ion abundance criteria	Retune instrument and verify	Laboratory Analyst/Section Manager	6 TO-15
GCMS	Minimum 5- Point ICAL	Prior to sample analysis	RSD ≤ 15%	Correct problem then repeat ICAL.	Laboratory Analyst/Section Manager	6 TO-15
GCMS	ICV (second source)	After each initial calibration curve, and daily prior to sample analysis	All reported analytes within ± 20% of true value	Correct problem. Rerun ICV. If that fails, repeat ICAL.	Laboratory Analyst/Section Manager	6 TO-15
GCMS	CCV	Daily before sample analysis; after every 12 hours of analysis time; and at the end of the analytical batch run.	All reported analytes and surrogates within ± 20% of true value. All reported analytes and surrogates within ± 50% for end of analytical batch CCV	Immediately analyze two additional consecutive CCVs. If both pass, samples may be reported without reanalysis. If either fails or if two consecutive CCVs cannot be run, perform corrective action(s) and repeat CCV and all associated samples since last successful CCV. Alternately, recalibrate if necessary; then reanalyze all associated samples since the last acceptable CCV.	Laboratory Analyst/Section Manager	6 TO-15

**Notes:**

<sup>1</sup> SOPs are listed on Worksheet #23.

<sup>2</sup> Applies only to compounds not listed as COCs for groundwater in Table 1 of the OU2 Landfills ROD (Army, 1994).

### 6.3 Worksheet #25: Analytical Instrument and Equipment Maintenance, Testing, and Inspection

Analytical instruments used for this project will be maintained in accordance with the requirements presented in the Eurofins QA Manual and the individual analytical method SOPs. The Eurofins QA Manual also presents the documentation requirements for maintenance activities.

Instrument/ Equipment	Maintenance Activity	Testing Activity	Inspection Activity	Frequency	Acceptance Criteria	Corrective Action	Responsible Person(s)	SOP Reference <sup>1</sup>
GCMS	Check for leaks, replace gas line filters, replace column, clean injection port/liner	VOC	Monitor instrument performance via tune and CCV	As needed	Calibration and QC criteria met	Replace connections, clean source, replace gas line filters, replace GC column, clip column, replace injection port liner, clean injection port, replace electron multiplier	Laboratory Analyst/ Section Manager	6
GC- Flame Ionization Detector	Clean injection port and replace liner, clip/replace column	Gases	Monitor instrument performance via Continuing Calibration	Daily	Calibration and QC criteria met	Change column instrument maintenance	Laboratory Analyst/ Section Manager	54
Sulfur Chemiluminescence Detector	Inspect the system, clean sample introduction line	Sulfur Gases	Monitor instrument performance via Continuing Calibration	Daily	Calibration and QC criteria met	Evaluate system	Laboratory Analyst/ Section Manager	13

<sup>1</sup>SOPs are listed on Worksheet #23.

#### 6.4 Worksheets #26 and #27: Sample Handling, Custody, and Disposal

Sampling Organization: Ahtna

Laboratory: Eurofins

Method of sample delivery (shipper/carrier): Overnight Courier

Number of days from reporting until sample disposal: No less than 30 days after final report sent to the client

Activity	Organization and Title or Position of Person Responsible for the Activity	SOP Reference <sup>1</sup>
Sample labeling	Ahtna/Field Technician	Field SOP #3
Chain of custody form completion		
Packaging		
Shipping coordination		
Sample receipt, inspection, & log-in	Eurofins Sample Management Supervisor	Not applicable
Sample custody and storage		
Sample disposal		

<sup>1</sup>Field SOPs are listed in Worksheet #21 and included in Attachment A.

## 6.5 Worksheet #28: Analytical Quality Control and Corrective Action

The following tables provide guidance for the evaluation of QC analyses and the implementation of corrective action for situations outside of acceptance limits. The method-specific acceptance criteria are presented in the applicable table in Worksheet #12 and Worksheet #15. For QC and corrective action specific to the field methods used by the mobile laboratory, refer to the method (EPA Methods 3A, 7E, 10, and 25A), which can be found at <https://www.epa.gov/emc/emc-promulgated-test-methods>.

### 6.5.1 Analytical Group/Method/SOP: Fixed Gases/ASTM D1945/SOP #54

QC Sample:	Frequency/Number	Method/SOP QC Acceptance Limits	Corrective Action	Responsible Person(s)	Project Measurement Performance Criteria
Method Blank	1 per extraction batch	Target analytes not detected $\geq$ LOQ and $>1/10$ the amount measured in any sample or $1/10$ the regulatory limit (whichever is greater)	Reanalyze samples; qualify as needed	Laboratory Analyst/Section Manager	Representativeness
LCS (Lab QC)	1 per batch	Laboratory-specific %R acceptance criteria	Evaluate system; reanalyze	Laboratory Analyst/Section Manager	Accuracy/Bias
Laboratory Duplicate	1 per batch	Laboratory-specific RPD acceptance criteria	Evaluate system; reanalyze	Laboratory Analyst/Section Manager	Precision
Relative Retention Time (RRT) Position	Confirmed at method setup and after major maintenance	RT windows established by calculating the standard deviation of the mean absolute retention time over a 72-hour period. 3 x standard deviation must be $<0.08$ min for analysis to proceed	Correct problem; recalibrate instrument; reanalyze results as necessary	Laboratory Analyst/Section Manager	Analyte Identification

**6.5.2 Analytical Group/Method/SOP: Sulfur Gases/ASTM D5504/A.5504.04**

QC Sample:	Frequency/ Number	Method/SOP QC Acceptance Limits	Corrective Action	Responsible Person(s)	Measurement Performance Criteria
Method Blank	1 per extraction batch	Target analytes not detected $\geq$ LOQ and $>1/10$ the amount measured in any sample or $1/10$ the regulatory limit (whichever is greater)	Reanalyze samples; qualify as needed	Laboratory Analyst/Section Manager	Representativeness
LCS (Lab QC)	1 per batch	Laboratory-specific %R acceptance criteria	Evaluate system; reanalyze	Laboratory Analyst/Section Manager	Accuracy/Bias
Laboratory Duplicate	1 per batch	Analyte-specific RPD acceptance criteria	Evaluate system; reanalyze	Laboratory Analyst/Section Manager	Precision

### 6.5.3 Analytical Group/Method/SOP: VOCs/TO-15/SOP #6

QC Sample:	Frequency/ Number	Method/SOP QC Acceptance Limits	Corrective Action	Responsible Person(s)	Measurement Performance Criteria
Method Blank	1 per extraction batch	Target analytes not detected >½ LOQ for all compounds with the exception of common laboratory contaminants which not detected >LOQ; and >1/10 the amount measured in any sample or 1/10 the regulatory limit (whichever is greater)	Reanalyze samples; qualify as needed	Laboratory Analyst/Section Manager	Representativeness
LCS (Lab QC)	1 per batch	See Worksheet #12	Evaluate system; reanalyze	Laboratory Analyst/Section Manager	Accuracy/Bias
Laboratory Duplicate	1 per batch	Analyte-specific RPD acceptance criteria	Evaluate system; reanalyze	Laboratory Analyst/Section Manager	Precision
Surrogate	1 per blank, sample, and standard	Surrogate-specific %R acceptance criteria	Evaluate system and samples; reanalyze	Laboratory Analyst/Section Manager	Accuracy/Bias
Internal Standard Performance	Every sample	Peak area ± 40 % of the peak area in the corresponding CCV; retention time within ±20 seconds of the corresponding CCV	Reanalyze or qualify results as necessary	Laboratory Analyst/Section Manager	Accuracy/Bias
RRT Position	Once per initial calibration and at the beginning of the analytical shift	RRT within ±0.06 RRT units for each analyte and surrogate	Correct problem; recalibrate instrument; reanalyze results as necessary	Laboratory Analyst/Section Manager	Analyte Identification
Mass Spectrometer Results	All positive results must be confirmed	Spectral match to reference spectrum	Analyst must evaluate results to confirm identification if spectral match does not meet criteria; Section Manager must review analyst's determination	Laboratory Analyst/Section Manager	Analyte Identification



## 7.0 Data Management and Data Review

### 7.1 Worksheet #29: Project Documents and Records

At a minimum, the following documentation will be used for sample collection and field measurement activities. Examples of field forms are presented in Attachment C.

<b>Sample Collection and Field Records</b>			
<b>Record</b>	<b>Generation</b>	<b>Verification</b>	<b>Storage location/archive</b>
Field notes/logbook	Field Team Lead	Project Manager	Project File*
Chain of custody forms	Field Team Lead	Project Manager	Project File
Laboratory raw data package	Eurofins	Project Chemist	Project File
PDF copy of analytical data	Eurofins	Project Chemist	Fort Ord Administrative Record
Audit/assessment checklists/reports	Field Team Lead/Project Chemist	Project Manager	Project File
Corrective action reports	Field Team Lead/Project Chemist	Project Manager	Project File
Laboratory sample custody log	Eurofins	Project Chemist	Project File
Laboratory equipment calibration logs	Eurofins	Project Chemist	Project File
Sample preparation logs	Eurofins	Project Chemist	Project File
Run logs	Eurofins	Project Chemist	Project File
Sample disposal records	Eurofins	Project Chemist	Project File
Validated data	Project Chemist	Program Chemist	Project File
Electronic Validated data	Data Validation Subcontractor	Project Chemist	Fort Ord Data Integration System (FODIS) chemistry database
Data Validation Reports	Project Chemist	Program Chemist	Project File
Annual Report	Task Manager	USACE Project Manager	Fort Ord Administrative Record

\*The Project File is maintained on a secure server accessible at the OU2 Groundwater Treatment Plant.

## 7.2 Worksheets #31, #32 and #33: Assessments and Corrective Action

### Assessments:

Assessment Type	Responsible Personnel and Organization	Number and Frequency	Assessment Deliverable	Deliverable Due Date
Review of QAPP, SOPs, and Accident Prevention Plan with Field Staff	FTL/Ahtna	Prior to sampling startup and with all new field staff prior to assignment	Completed acknowledgement signature pages	48 hours following assessment
Work performed in accordance with site-specific QAPPs	FTL/Ahtna	Ongoing during all phases of fieldwork	Daily progress reports	24 hours following conclusion of business day
Logbook and Field Form Review	FTL/Ahtna	Daily	NA; corrections will be made directly to reviewed documents	24 hours following assessment
Laboratory Assessment for Appropriate Certifications, Capacity, and QAPP Review with Staff	Project Chemist/Ahtna	Prior to sampling mobilization, as new laboratories are contracted	Receipt of copies of certifications. Email traffic concerning lab capacity prior to sampling startup. QAPP sign-off sheet received from laboratory	48 hours following assessment
Tailgate Safety Meeting	SSHO/Ahtna	Daily	Verbal debriefing and daily sign-off log. If a safety incident occurs, a Supervisor Injury Employee Report is completed	Weekly; any safety incidents will be reported to the PM and Corporate Health and Safety Officer immediately
Daily QC Reports	FTL/Ahtna	Ongoing during all phases of fieldwork	Three Phase Inspection Forms (Attachment D)	24 hours following conclusion of business day
Field Sampling and Chain of Custody Form Review Against QAPP Requirements	Project Chemist/Ahtna	Daily	Corrections will be made directly to reviewed documents; communication may be in the form of email	24 hours following assessment

Assessment Type	Responsible Personnel and Organization	Number and Frequency	Assessment Deliverable	Deliverable Due Date
Data Validation	Data Validation Chemist/ Laboratory Data Consultants	Per Sample Delivery Group	Communication may be in the form of email traffic. Amendment of the analytical report or corrective actions due to deficiencies identified in the validation process	24 hours following assessment
Laboratory Report Deliverables and Analytical Results Against QAPP Requirements	Project Chemist/Ahtna	As discrepancies are identified in the validation process	Memorandum or email to PM and Project Chemist	72 hours following assessment

**Assessment Response and Corrective Action:**

Assessment Type	Individual(s) Notified of Findings	Assessment Response Documentation	Time Frame for Response	Responsibility for Implementing Corrective Action	Responsibility for Monitoring Corrective Action
Review of QAPP, SOPs, and Accident Prevention Plan with Field Staff	FTL	Completed acknowledgement signature pages	48 hours following assessment	FTL	PM and QC Manager
Work performed in accordance with site-specific QAPP	PM	Interim CA documented pending final approval	By close of same business day	FTL	PM and QC Manager
Logbook and Field Form Review	FTL	Corrections will be made directly to reviewed documents	NA	FTL	PM
Laboratory Assessment for Appropriate Certifications, Capacity, and QAPP Review with Staff	Project Chemist	Response to email or memorandum	48 hours after notification	Laboratory PM	Project Chemist

Assessment Type	Individual(s) Notified of Findings	Assessment Response Documentation	Time Frame for Response	Responsibility for Implementing Corrective Action	Responsibility for Monitoring Corrective Action
Tailgate Safety Meeting	FTL	Included as part of the process of the Supervisor Injury Employee Report	24 hours after notification	Ahtna PM	Corporate H&S Manager
Daily QC Reports	FTL	Corrections will be made directly to reviewed documents	NA	FTL	PM and QC Manager
Field Sampling and Chain of Custody Form Review Against QAPP Requirements	Project Chemist	Response to email	48 hours after notification	FTL	PM and QC Manager
Data Validation	Project Chemist	If required, laboratory reports will be amended and corrections noted in the analytical narrative and contained with the validation report	1 business week	Data Validation PM	Project Chemist
Laboratory Report Deliverables and Analytical Results Against QAPP Requirements	Project Chemist	If required laboratory reports will be amended and corrections noted in the analytical narrative	72 hours after notification	Laboratory PM	Laboratory QA Manager/ Project Chemist

### 7.3 Worksheet #34: Data Verification and Validation Inputs

This worksheet lists the inputs that will be used during data verification and validation. Inputs include planning documents, field records, and laboratory records. Data verification is a check that all specified activities involved in collecting and analyzing samples have been completed and documented and that the necessary records (objective evidence) are available to proceed to data validation. Data validation is the evaluation of conformance to stated requirements, including those in the contract, methods, SOPs and the QAPP.

Item	Description	Verification (completeness)	Validation (conformance to specifications)
<b>Planning Documents/Records</b>			
1	Approved QAPP	X	
2	Contract	X	
4	Field SOPs	X	
5	Laboratory SOPs	X	
<b>Field Records</b>			
6	Field Logbooks	X	X
7	Equipment Calibration Records	X	X
8	Chain of Custody Forms	X	X
9	Sampling Diagrams/Surveys	X	X
10	Relevant Correspondence	X	X
11	Change Orders/Deviations	X	X
12	Field Audit Reports	X	X
13	Field CA Reports	X	X
<b>Analytical Data Package</b>			
14	Cover Sheet (laboratory identifying information)	X	X
15	Case Narrative	X	X
16	Sample Chronology (e.g., dates and times of receipt, preparation, and analysis)	X	X
17	LOD/LOQ Establishment and Verification	X	X
18	Standards Traceability	X	X
19	Instrument Calibration Records	X	X
20	Definition of Laboratory Qualifiers	X	X
21	Results Reporting Forms	X	X
22	QC Sample Results	X	X
23	CA Reports	X	X
24	Raw Data	X	X
25	Chromatograms	X	X
26	Electronic Data Deliverable	X	X

## 7.4 Worksheet #35: Data Verification Procedures

Records Reviewed	Requirement Documents	Process Description	Responsible Person, Organization
Methods	QAPP, SOP	Records support implementation of the SOP-sampling and analysis.	Project Chemist, Ahtna
Performance Requirements	QAPP, SOP	Verify laboratory method SOPs are sufficient to satisfy DQOs.	Program Chemist, Ahtna
Sampling Locations, Number of Samples	QAPP, SOP	Verify that sample locations and quantities will be sufficient to satisfy DQOs.	Program Chemist, Ahtna
Three phase inspection forms and Other Field Documentation	QAPP, SOP	Review daily sampling activity reports including pertinent field sampling data.	Project Chemist, Ahtna
Chain of Custody	QAPP, SOP	Examine traceability of data from sample collection to generation of project reported data.	Project Chemist, Ahtna
Deviations	QAPP, SOP	Determine impacts of any deviations from methods.	Program Chemist, Ahtna
Sensitivity	QAPP, SOP	Verify that LODs and LOQs are achieved as outlined in the QAPP and that the laboratory successfully analyzed a standard at the LOD.	Project Chemist, Ahtna
Precision	QAPP, SOP	Review data against performance criteria and determine impact of any result out of criteria.	Project Chemist, Ahtna
Accuracy	QAPP, SOP	Review data against performance criteria and determine impact of any result out of criteria.	Project Chemist, Ahtna
QC samples	QAPP, SOP	Ensure that a sufficient number of QC samples are analyzed, as outlined in the QAPP, to meet DQOs.	Project Chemist, Ahtna
Field Change Requests	QAPP, SOP	Review any change request or corrective action documentation. Determine impact to project objectives.	Project/Program Chemist, Ahtna
Electronic Data Deliverables (EDDs)	QAPP	Verify that acceptable EDDs have been qualified. The Laboratory Data Consultants Automated Data Review (LDC ADR) EDD format files will be uploaded into the FODIS chemistry database, EDD files will be submitted to USACE. EDD File Specifications are provided in Attachment E.	Project Chemist, Ahtna

## 7.5 Worksheet #36: Data Validation Procedures

Analytical Group/Method:	Volatile Organics – TO-15 (Modified)	Gases – ASTM D1945, D5504
Data deliverable requirements:	LDC ADR	LDC ADR
Analytical specifications:	Worksheet #28	Worksheet #28
Measurement performance criteria:	Worksheet #12	Worksheet #12
Percent of data packages to be validated:	100%	100%
Percent of raw data reviewed:	10%	10%
Percent of results to be recalculated:	10%	10%
Validation procedure:	DoD Data Validation Guidelines	DoD Data Validation Guidelines
Validation qualifiers:	See table below	See table below
Electronic validation program:	LDC ADR	LDC ADR

DoD Data Validation Guidelines = Department of Defense General Data Validation Guidelines Environmental Data Quality Workgroup (DoD, 2018)

LDC ADR = Laboratory Data Consultants Automated Data Review format

### Summary of Data Qualifiers

Qualifier	Definition
U	The analyte was not detected and was reported as less than the LOD or as defined by the customer. The LOD has been adjusted for any dilution or concentration of the sample.
J	The reported result was an estimated value with an unknown bias.
J+	The result was an estimated quantity, but the result may be biased high.
J-	The result was an estimated quantity, but the result may be biased low.
N	The analysis indicates the presence of an analyte for which there was presumptive evidence to make a "tentative identification."
NJ	The analyte has been "tentatively identified" or "presumptively" as present and the associated numerical value was the estimated concentration in the sample.
UJ	The analyte was not detected and was reported as less than the LOD or as defined by the customer. However, the associated numerical value is approximate.
X	The sample results (including non-detects) were affected by serious deficiencies in the ability to analyze the sample and to meet published method and project quality control criteria. The presence or absence of the analyte cannot be substantiated by the data provided. Acceptance or rejection of the data should be decided by the project team (which should include a project chemist), but exclusion of the data is recommended.

## 7.6 Worksheet #37: Data Usability Assessment

<b>Step 1</b>	<p><b>Review the project’s objectives and sampling design</b></p> <p>The goal for O&amp;M activities at Fort Ord is to implement remedies as necessary to protect human health and the environment while maximizing the number of site closures or advance sites as close to site closure as practicable during the Period of Performance in a cost-effective manner. The site-specific QAPPs will indicate the project objectives and sampling design. To that end, the usability assessment will incorporate the activities listed below.</p> <p><b>Field Certification</b></p> <p>Field personnel will generate field forms, maps, and notes describing the daily procedures. The three-phase inspection forms (Attachment D), generated during sampling, will discuss any successes and/or deviations from the QAPP. The FTL will review all field documentation as it is generated for consistency and errors. Any anomalies identified will be discussed with the project team to determine if any changes to the sampling design are needed. Any changes will be documented in a QAPP amendment.</p> <p><b>Data Quality Indicators: Precision, Accuracy, Representativeness, Comparability, Completeness, and Sensitivity (PARCCS)</b></p> <p>The PARCCS parameters will be used to help identify deficiencies in the sample data that would affect the achievement of the project DQOs. Laboratory limits and QC samples will be used as part of the PARCCS assessment to detect anomalies in the dataset. In addition, the laboratory will create trend charts to track variability in laboratory processes and establish in-house precision and accuracy criteria.</p> <p>Laboratory limits used in the sensitivity review consist of the LOD and LOQ. Laboratory QC samples consist of method blanks, LCSs, surrogates, and laboratory duplicates. All samples will be spiked with surrogate compounds where recommended or required by the method.</p> <p><b>Precision</b></p> <p>Precision is defined as the degree of mutual agreement between individual measurements of the same property under similar conditions and provides a measurement of the reproducibility of an analytical result. Precision will be evaluated through the analysis of field duplicate samples and LCSs. Field duplicate samples will be collected at a frequency of one per 10 field samples of a given matrix. The duplicate sample will not be reanalyzed when the RPD criteria are not met. Discussion of QC failures will be documented in the laboratory case narrative. The Project Chemist will work with the laboratory to determine the cause of the failure and to determine if any of the QC failures are due to matrix or sampling error and if the failures have an impact on the project objectives.</p> <p>The variance between the samples, in terms of RPD, is calculated according to the</p>
---------------	---



following equation:

$$RPD = \frac{|A - B|}{(A + B)/2} \times 100\%$$

where: A = First duplicate concentration

B = Second duplicate concentration

For this project, the goal for precision of field duplicates is listed in Worksheet #12. In the event that both of the duplicate sample results are less than the LOD, the RPD will not be calculated

### **Accuracy**

Accuracy is the degree of agreement between an analytical measurement and a reference accepted as a true value. The accuracy of a measurement system can be affected by errors introduced by field contamination, sample preservation, sample handling, sample preparation, or analytical techniques. A program of sample spiking will be conducted to evaluate laboratory accuracy. Accuracy will be evaluated by the percent recovery of the spiked compounds in the LCSs, surrogates, and proficiency samples (if requested by the PM). LCSs and surrogates will be spiked prior to extraction. LCS samples will be spiked with the method target compounds indicated in this QAPP, and surrogates will be added to every sample and spike. Proficiency samples will be taken through the entire sample preparation and analysis process. LCS or blank spike samples will be analyzed at a frequency of 5%, or one per sample delivery group/analytical batch (sample sets can be up to 20 field samples). Proficiency samples will be analyzed once per sampling event if required. The results of the spiked and proficiency samples are used to calculate the percent recovery for evaluating accuracy, using the following equation:

$$\text{Percent Recovery} = \frac{S - C}{T} \times 100$$

where:

S = Measured spike sample concentration

C = Sample concentration

T = True or actual concentration of the spike or proficiency

Worksheet #12 presents accuracy goals for this investigation based on the percent recovery of LCSs and surrogate spikes. The data reviewer will use the accuracy results to help determine if any of the QC failures are due to matrix or sampling error and if the failures have an impact on the project objectives.

The presence of high levels of target compounds in the sample chosen for spiking may necessitate a dilution of the sample, or may otherwise result in errors in spiked compound recovery. Discussion of laboratory QC failures will be documented in the

laboratory case narrative. The Project Chemist will work with the laboratory to determine the cause of the failure and to determine if any of the QC failures are due to matrix or sampling error and if the failures have an impact on the project objectives.

**Representativeness**

Representativeness expresses the degree to which sample data accurately and precisely represent the characteristics of a population, variations in a parameter at a sampling point, or an environmental condition that the data are intended to represent. For this project, representative data will be obtained through careful selection of sampling locations and analytical parameters, through proper collection and handling of samples to avoid interference and minimize cross-contamination, and through consistent application of the appropriate established field and laboratory procedures.

To aid in evaluating the representativeness of the sample results, laboratory blank samples will be evaluated for the presence of contaminants. Laboratory procedures will be reviewed to verify that SOPs were followed and method requirements were met during the analysis of project samples. Laboratory sample storage practices, holding times, sub-sampling procedures, method blanks, and will be assessed for potential impacts on the representativeness of the data. Data determined to be non-representative will be used only if accompanied by appropriate qualifiers and limits of uncertainty.

Representativeness as it relates to field procedures refers to the collection of samples that allow accurate conclusions to be made regarding the composition of the sample media at the entire site. Representativeness will be assessed qualitatively by evaluating whether the procedures described in this QAPP were followed.

**Completeness**

Completeness is a measure of the percentage of project-specific data that are valid. Valid data are obtained when samples are collected and analyzed in accordance with the procedures outlined in this QAPP and when none of the QC criteria used to determine the usability of the data is critically exceeded to the point of rejection.

When data validation is completed, the percent completeness value will be calculated by dividing the number of usable sample results by the total number of sample results planned for this investigation. The evaluation of completeness will help determine whether any critical deficiencies identified during the validation process resulted in non-attainment of project objectives.

Completeness will be evaluated by reviewing the tasks that contribute to the sampling event, such as sample handling and storage procedures, chain of custody procedures, analytical procedures, and data validation procedures. The procedures and determined impact on the sample results will be used to identify any problems along the data path that will render the decision-making process useless and the data set incomplete. The completeness goal for this project that still allows for attainment of the project objectives

is 90%.

$$\frac{\text{Number of possible analyte results} - \text{Number of rejected and unreported results}}{\text{Possible number of analyte results}} \times 100$$

The project team may determine that an individual sampling point or area is more critical than others for decision-making. Any sampling locations identified as such will have a completeness goal of 95% as determined by the validation process.

**Comparability**

Comparability expresses the confidence with which one dataset can be compared with another. Comparability of data will be achieved by following standard field and laboratory procedures outlined in SOPs and published methods. In addition, standard units of measurement will be used in reporting analytical and field data. Analytical and field methods selected for this investigation are consistent with the methods used during previous investigations of this type. Oversight by experienced team members will ensure that the procedures are conducted in a manner appropriate to attaining the project objectives. Any deviations from field or laboratory methods will be documented on a change request form. The project team will review the change request to determine if the change will impact the comparability of the data.

**Sensitivity**

The LOD, and LOQ will be evaluated by the project team prior to sample analysis to determine if the laboratory is able to attain the sensitivity required for the project. If project decision limits are too sensitive, it will be determined prior to sample analysis whether a sensitivity variance will be issued to the laboratory based on the method chosen and the technology available.

The LOD is the minimum quantity of an analyte that can be reliably detected for a specific analytical method at a 99% confidence level that the value is not a false negative. The LOQ represents the smallest quantity of an analyte that can be quantified accurately and reproducibly in a given sample matrix (e.g., three to five times the LOD). The LOD and/or the LOQ shall be sensitive enough to meet the project decision limits. The LOD and LOQ will be evaluated after sample analysis to determine if there were any matrix effects, operator errors, or analytical process errors that interfered with the ability to compare the results to the project decision limits. The LOD will be used to determine if detectable amounts of analytes are present. If no detectable amounts are reported, and all data are acceptable (as determined by the verification and validation process), then the data are usable. The LOD will be used to determine if any detectable amounts of contaminants of concern are present. If detectable amounts are reported and the verification and validation are acceptable, then the data are usable. Any detections falling between the LOD and LOQ will be qualified as estimated. If anomalies in sensitivity are present, the rationale for use or non-use of the affected samples will be discussed in the data

	validation reports. Worksheet #15 presents the laboratory LODs and LOQs for the selected analytical method(s) used to support the project decision limits.
<b>Step 2</b>	<p><b>Review the data verification and data validation outputs</b></p> <p>The outputs from the verification and validation process will be used to determine data usability. Data validation reports and three phase inspection forms will be reviewed. Data will be summarized as necessary using graphs, maps, and/or tables. The entire project team is responsible for assessing whether the data meet the project objectives. Personnel at all levels will generate data and documentation that will be reviewed to identify trends, relationships, and/or anomalies in the dataset.</p>
<b>Step 3</b>	<p><b>Implement the statistical method</b></p> <p>For each analytical method, the laboratory will use the LCS data to track and analyze trends in the laboratory. From these trends, they can recognize deficiencies in the method and create in-house acceptance criteria. For this project, the limits are based on laboratory control limits. The precision and accuracy of the entire dataset will be used to determine if any systemic problems have occurred during the sampling event that will result in deficiencies in the dataset. The occurrence of systemic problems and the resulting consequences will be discussed in the data validation report. The data reviewer will make every effort to identify any critical elements or trends that would result in non-usability of data as early as possible.</p>
<b>Step 4</b>	<p><b>Document data usability and draw conclusions</b></p> <p>Again, the entire project team is responsible for assessing whether the data meet the project objectives. The site-sampling layout, including sampling locations, frequency of sampling, and timing of sampling activities, will be reviewed by the project team. Data usability will be assessed in accordance with the guidance provided in DoD QSM Version 5.3 and additional applicable USACE and EPA guidance as well as the professional experience of the decision maker during data validation. The conclusions will be discussed in the final annual report. If the data indicate anomalies, the impacted data will be qualified as described in EM-200-1-10. The impact will be documented along with the rationale for limited use of the data.</p>

## 8.0 References<sup>6</sup>

- Ahtna Environmental, Inc. (Ahtna), 2016a. *Quality Assurance Project Plan, Former Fort Ord, California, Volume I, Appendix D, Final Revision 1, Operable Unit 2 Landfills, Former Fort Ord California*. May. AR# [OU2-702B](#).
- Ahtna, 2016b. *Final Annual Report, 2015, Operations and Maintenance, Operable Unit 2 Landfills, Former Fort Ord California*. May. AR# [OU2-703](#).
- Ahtna, 2017. *Final Annual Report, 2016, Operations and Maintenance, Operable Unit 2 Landfills, Former Fort Ord California*. July. AR# [OU2-708](#).
- Ahtna, 2018. *Final Annual Report, 2017, Operations and Maintenance, Operable Unit 2 Landfills, Former Fort Ord California*. May. AR# [OU2-712](#).
- Ahtna, 2019. *Final Annual Report, 2018, Operations and Maintenance, Operable Unit 2 Landfills, Former Fort Ord California*. May. AR# [OU2-718](#).
- California Department of Toxic Substances Control (DTSC). 2019. Human and Ecological Risk Office (HERO), Human Health Risk Assessment (HHRA) Note Number: 3, DTSC modified Screening Levels. June. <https://dtsc.ca.gov/wp-content/uploads/sites/31/2019/04/HHRA-Note-3-2019-04.pdf>
- Dames & Moore, 1993. *Baseline Risk Assessment, Remedial Investigation/Feasibility Study, Site 2 Landfills, Fort Ord, California*. June 7. AR# [OU2-218](#).
- Department of Defense (DoD), 2013. *DoD Environmental Field Sampling Handbook, Revision 1.0*. Chapter 3. Common Sampling Procedures. April. Available from: <http://docplayer.net/15449171-Dod-environmental-field-sampling-handbook-revision-1-0.html>. Accessed January 2017.
- DoD Environmental Data Quality Workgroup, 2019. Department of Defense Quality Systems Manual for Environmental Laboratories, Final Version 5.3. <https://www.denix.osd.mil/edqw/documents/documents/gsm-version-5-3-final/>
- DoD, 2018. Department of Defense General Data Validation Guidelines, Environmental Data Quality Workgroup, February. <https://www.denix.osd.mil/edqw/documents/documents/general-data-validation-guidelines-final/>
- Gilbane Company, 2015. *Final Annual Report, 2014, Operations and Maintenance, Operable Unit 2 Landfills, Former Fort Ord California*. July. AR# [OU2-696](#).
- Intergovernmental Data Quality Task Force (IDQTF), 2005. *Uniform Federal Policy for Quality Assurance Project Plans, Part 1: UFP-QAPP Manual, Final Version 1*. March.

---

<sup>6</sup> At the end of references included in the Fort Ord Administrative Record are the Administrative Record Numbers (AR#s) (e.g. OU2-123). To find the referenced document, this number may be typed into the online search tool at: <http://www.fortordcleanup.com/documents/search/>. Please note the referenced documents were available in the Fort Ord Administrative Record at the time this document was issued; however, some may have been superseded by more current versions and were subsequently withdrawn.

IDQTF, 2012. *Uniform Federal Policy for Quality Assurance Project Plans, Part 2a, Revision 1: Optimized UFP-QAPP Worksheets*. March.

IT Corporation, 2001. *Draft Final Remedial Action Confirmation Report and Post-Remediation Screening Risk Assessment Area A, Operable Unit 2 Landfills, Former Fort Ord, CA*. April. AR# [OU2-599A](#).

Shaw Environmental, Inc. (Shaw), 2005a. *Draft Final Remedial Action Construction Completion Report, Operable Unit 2 Landfills, Areas A through F, Former Fort Ord, California*. January 31. AR# [OU2-630B](#).

Shaw, 2005b. *Draft Final Evaluation Report, Landfill Gas Pilot Test, Operable Unit 2 Landfills, Former Fort Ord, California*. August 19. AR# [OU2-627A](#).

Shaw, 2005c. *Draft Final Report, 2003 Ambient Air Monitoring and Human Health Risk Assessment, Operable Unit 2 Landfills, Former Fort Ord, California, Revision 0*. March 3. AR# [OU2-647E](#).

Shaw, 2008a. *Operation and Maintenance Plan, Operable Unit 2 Landfills, Former Fort Ord, California, Revision 2*. September 4. AR# [OU2-593F](#).

Shaw, 2008b. *Final Construction Completion Report, Landfill Gas System Expansion, Operable Unit 2 Landfills, Former Fort Ord, California, Revision 0*. September 11. AR# [OU2-662F](#).

U.S. Department of the Army (Army), 1994. *Record of Decision, Operable Unit 2, Fort Ord Landfills, Fort Ord, California*. July. AR# [OU2-480](#).

Army, 1995. *Explanation of Significant Differences (ESD), Operable Unit 2, Fort Ord Landfills, Fort Ord, California*. August 3. AR# [OU2-406](#).

Army 1997a. *Explanation of Significant Differences Consolidation of Remediation Waste in a Corrective Action Management Unit (CAMU), Operable Unit 2 Landfill*. January 13. AR# [OU2-523](#).

Army, 1997b. *Record of Decision, Basewide Remedial Investigation Sites, Fort Ord, California*. January 13. AR# [RI-025](#).

Army, 2003. *Explanation of Significant Differences (ESD), Excavation and Segregation of Spent Ammunition from Soil, Site 39, Former Fort Ord, California*. October 31. AR# [BW-2274](#).

Army, 2006. *Explanation of Significant Differences, No Further Action for Munitions and Explosives of Concern, Landfill Gas Control, Reuse of Treated Groundwater, Designation of Corrective Action Management Unit (CAMU) Requirements as Applicable or Relevant and Appropriate Requirements (ARARs), Operable Unit 2, Fort Ord Landfills, Former Fort Ord, California*. August. AR# [OU2-656](#).

Army, 2009. *Record of Decision Amendment, Site 39 Inland Ranges, Former Fort Ord, California*. August 25. AR# [RI-041E](#).

U.S. Army Corps of Engineers (USACE), 1997. *Installation-Wide Habitat Management Plan for Former Fort, California*. April. AR# [BW-1797](#).

U.S. Environmental Protection Agency (EPA), 1999. *Compendium Method TO-15, Determination of Volatile Organic Compounds (VOCs) In Air Collected In Specially-Prepared Canisters And Analyzed By Gas Chromatography/Mass Spectrometry (GC/MS)*. January.

EPA, 2006. *Guidance on Systematic Planning Using the Data Quality Objectives Process*, EPA QA/G-4. February.

EPA, 2019. *Regional Screening Level (RSL) Resident Ambient Air Table (TR=1E-6, HQ=1)*. May.  
<https://semspub.epa.gov/work/HQ/199444.pdf>

## FIGURES



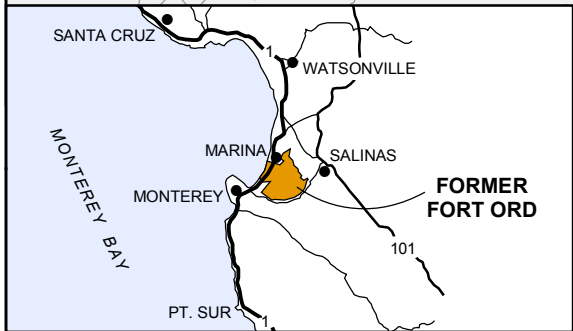
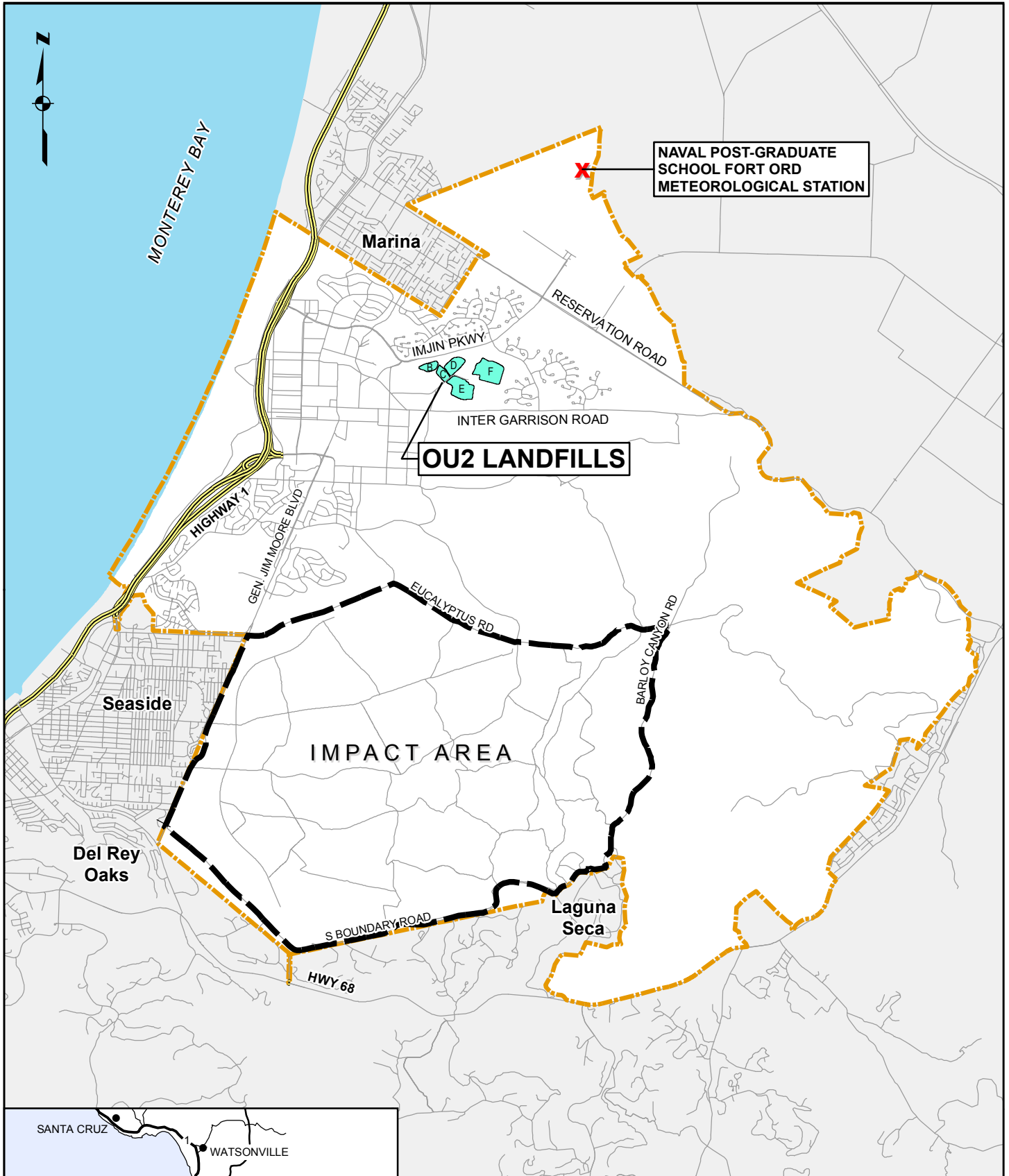

<b>FORMER FORT ORD</b>		
LOCATION MAP OU2 LANDFILLS		
		<b>FIGURE NUMBER</b> 1

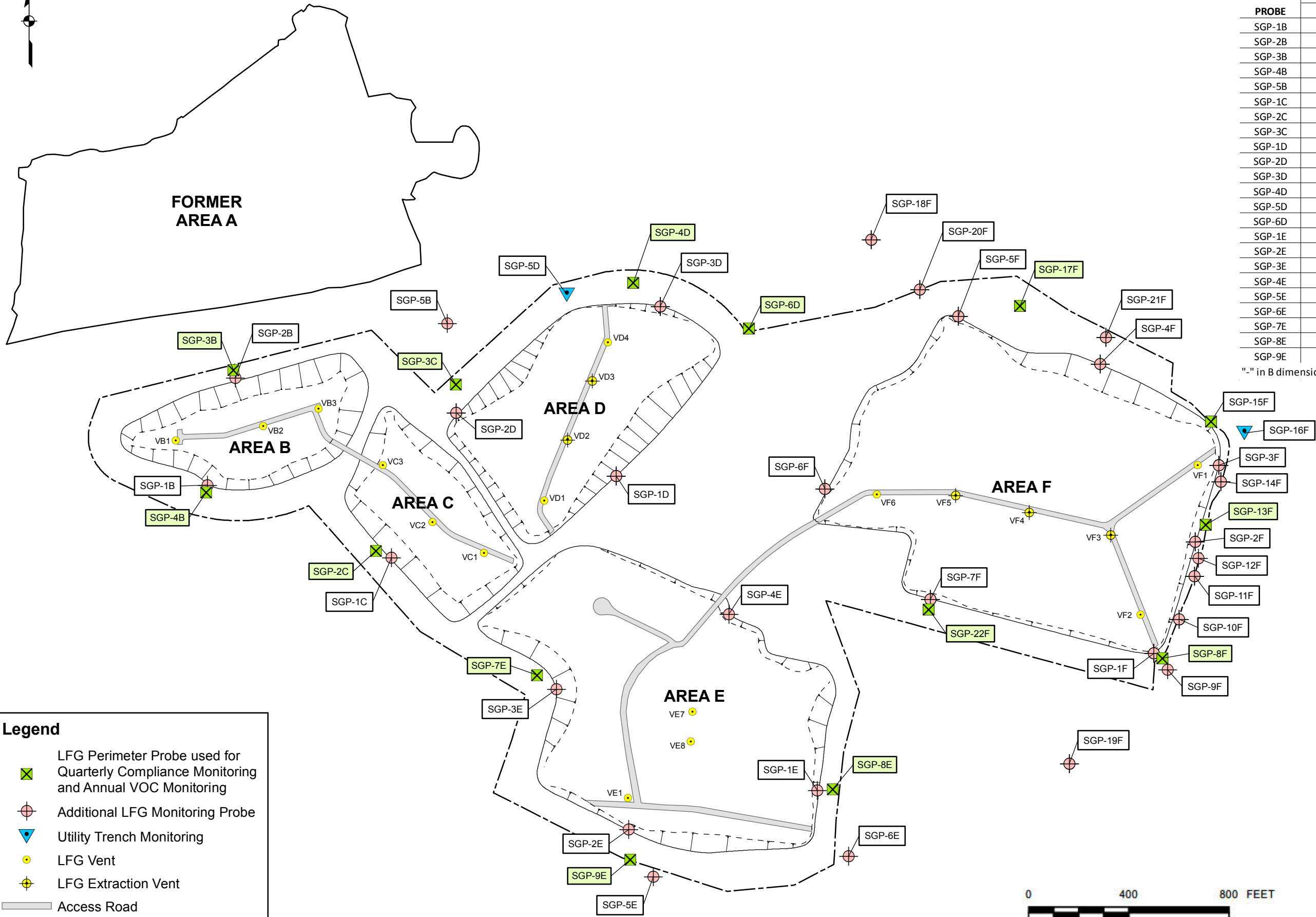

**PROBE DEPTH TABLE**

PROBE	DIMENSIONS (ft)		PROBE	DIMENSIONS (ft)	
	A	B		A	B
SGP-1B	12	-	SGP-1F	12	22
SGP-2B	12	-	SGP-2F	12	32
SGP-3B	12	-	SGP-3F	12	32
SGP-4B	12	-	SGP-4F	12	32
SGP-5B	12	-	SGP-5F	12	32
SGP-1C	12	-	SGP-6F	12	32
SGP-2C	12	-	SGP-7F	12	32
SGP-3C	12	-	SGP-8F	12	22
SGP-1D	12	22	SGP-9F	22	-
SGP-2D	12	22	SGP-10F	12	22
SGP-3D	12	22	SGP-11F	12	32
SGP-4D	12	22	SGP-12F	32	-
SGP-5D	4	-	SGP-13F	12	32
SGP-6D	12	22	SGP-14F	12	32
SGP-1E	12	-	SGP-15F	12	32
SGP-2E	12	-	SGP-16F	4	-
SGP-3E	12	-	SGP-17F	12	32
SGP-4E	12	-	SGP-18F	12	32
SGP-5E	12	-	SGP-19F	12	22
SGP-6E	12	-	SGP-20F	12	32
SGP-7E	12	-	SGP-21F	12	22
SGP-8E	12	-	SGP-22F	12	32
SGP-9E	12	-			

"-" in B dimension column means single probe

**Legend**

- LFG Perimeter Probe used for Quarterly Compliance Monitoring and Annual VOC Monitoring
- Additional LFG Monitoring Probe
- Utility Trench Monitoring
- LFG Vent
- LFG Extraction Vent
- Access Road
- Landfill Parcel Boundary



**FORMER FORT ORD**

Landfill Gas Monitoring Locations

FIGURE NUMBER  
2

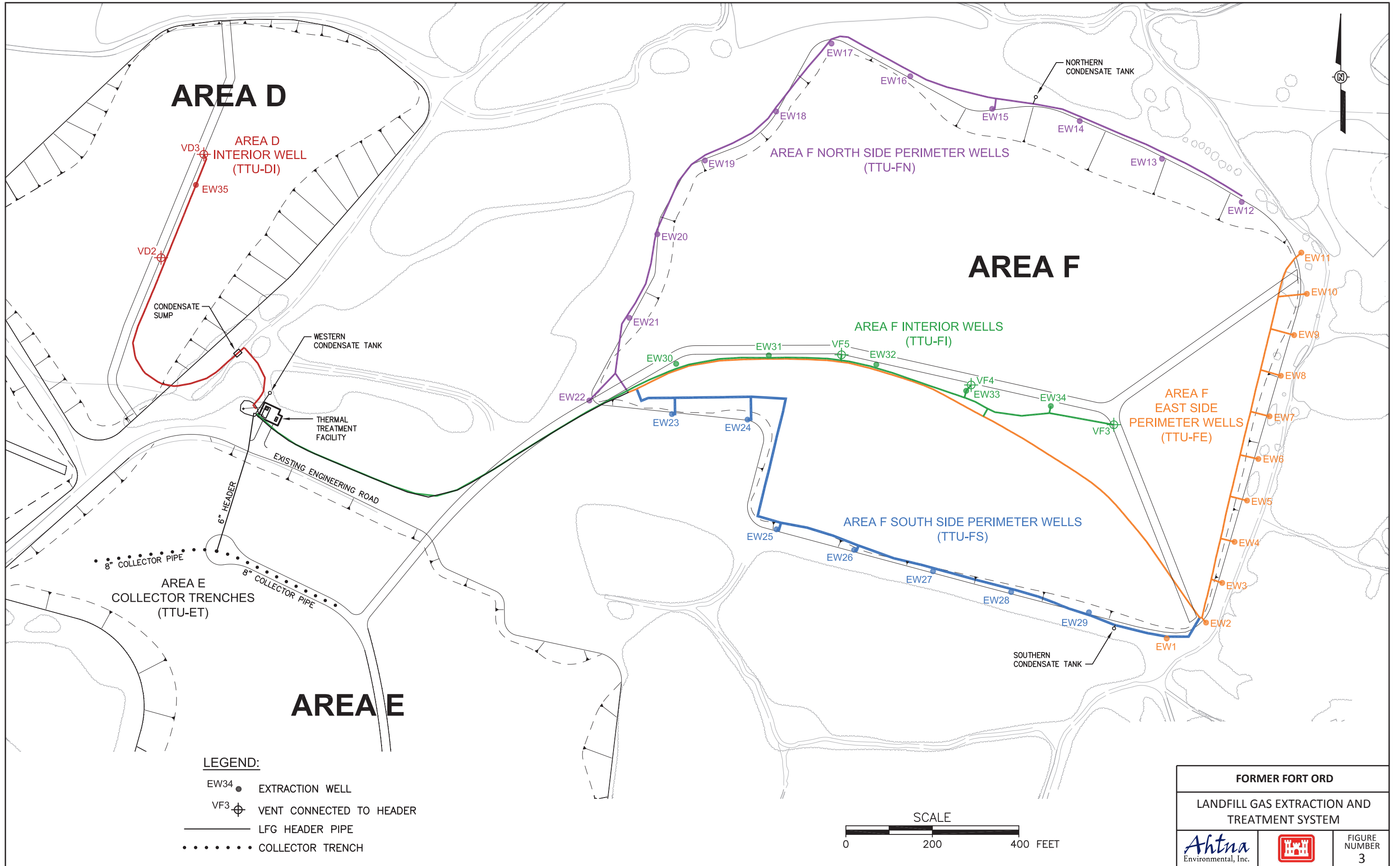

# AREA D

AREA D  
INTERIOR WELL  
(TTU-DI)

# AREA F

AREA F NORTH SIDE PERIMETER WELLS  
(TTU-FN)

AREA F INTERIOR WELLS  
(TTU-FI)

AREA F EAST SIDE PERIMETER WELLS  
(TTU-FE)

AREA F SOUTH SIDE PERIMETER WELLS  
(TTU-FS)

AREA E  
COLLECTOR TRENCHES  
(TTU-ET)

# AREA E

**LEGEND:**

- EW34 ● EXTRACTION WELL
- VF3 ⊕ VENT CONNECTED TO HEADER
- LFG HEADER PIPE
- ..... COLLECTOR TRENCH

<b>FORMER FORT ORD</b>		
LANDFILL GAS EXTRACTION AND TREATMENT SYSTEM		
		FIGURE NUMBER 3

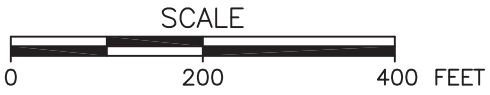

## **ATTACHMENTS**

## ATTACHMENT A

### Standard Operating Procedures (SOPs)

SOP No.	SOP Title	Author Organization
1	GEM™5000 Gas Analyzer & Extraction Monitor Operation Manual	LANDTEC
2	Guide to Air Sampling, Canisters and Bags	Eurofins
3	Field Sampling Procedure Using Summa Canisters with RAVEqc Quick-Connect (QT) Fittings	Eurofins
4	Common Sampling Procedures (Chapter 3 from DoD Environmental Field Sampling Handbook)	DoD



# GEM5000 Gas Analyzer

## Operating Manual



**QED Environmental Systems, Inc.**  
2355 Bishop Circle West  
Dexter, MI. 48130  
Tel: (800) 624-2026  
Fax : (734) 995-1170  
Email: [info@qedenv.com](mailto:info@qedenv.com)  
Website: [www.landtecna.com](http://www.landtecna.com)

Rev.2.1.2018

# GEM5000 Gas Analyzer

---

## Table of contents

<b>1.0</b>	<b>MANUAL GUIDELINES</b>	<b>5</b>
1.1	Hazard warnings and safety symbols	5
1.2	Notes	5
<b>2.0</b>	<b>INTRODUCTION</b>	<b>6</b>
2.1	Safety instructions	6
2.2	Instructions for safe use	7
2.3	MCERTS	9
2.4	CIRIA	9
<b>3.0</b>	<b>THE GEM5000 GAS ANALYSER</b>	<b>10</b>
3.1	The GEM5000	10
3.2	GEM5000 standard product	11
<b>4.0</b>	<b>GEM5000 OPTIONAL PRODUCTS AND ACCESSORIES</b>	<b>12</b>
4.1	Optional products	12
4.1.1	Pitot tube (optional)	12
4.1.2	Orifice plate (optional)	12
4.1.3	Temperature probe (optional)	12
4.1.4	Anemometer (optional)	12
4.1.5	H <sub>2</sub> S filter (optional)	13
4.1.6	LANDTEC Systems Gas Analyzer Manager – LSGAM	13
4.1.7	GPS (optional)	13
4.1.8	Bluetooth	13
<b>5.0</b>	<b>GEM5000 INSTRUMENT FEATURES</b>	<b>14</b>
5.1	Physical characteristics of the instrument panel	14
5.2	Analyser features and keys	145
5.3	Instrument connection points	156
<b>6.0</b>	<b>GENERAL OPERATIONAL INSTRUCTIONS</b>	<b>17</b>
6.1	Switching the instrument on	17
6.1.1	Power on self-test	17
6.2	Switching the analyser off	17
6.3	Instrument status icons	18
6.4	Instrument LED power states	19
6.5	Changing between parameters	19
6.6	Entering data	19
6.7	Instrument main gas read screen	20
6.8	Storage	20
6.9	Battery/charging	20
6.10	Cleaning instructions	21
6.11	Memory	22
6.12	Warning and error codes	22
<b>7.0</b>	<b>OPERATOR SETTINGS</b>	<b>22</b>
7.1	Menu key	22
7.2	Operation settings	23
7.2.1	Timers	23
7.2.2	Gas Check	24
7.2.3	View data	24
7.2.4	Set alarms	25
7.2.5	Adjust flow fail	26
7.2.6	Technician login	27
7.3	Device settings	28
7.3.1	Date and time	28
7.3.2	Bluetooth	29

# GEM5000 Gas Analyzer

---

7.3.3	Device information.....	30
7.3.4	Diagnostics.....	30
7.3.5	Navigation (optional).....	31
7.4	User settings.....	32
7.4.1	Operating language.....	32
7.4.2	Units of measurement.....	33
7.4.3	ID selection.....	34
7.4.4	Routes.....	36
7.4.5	Adjust backlight.....	36
7.4.6	Adjust volume.....	37
7.4.7	User Prompts.....	38
7.5	Exit menu.....	38
<b>8.0</b>	<b>TAKING READINGS.....</b>	<b>39</b>
8.1	Preliminary checks before taking readings (best practice).....	39
8.2	Change screen layout.....	41
8.3	Answering site questions.....	41
8.4	Answering ID questions.....	41
8.5	Special action.....	42
8.5.1	Configuration of the data logging option.....	43
8.5.2	Profiling option.....	43
8.6	GEM analyser in GA mode.....	44
8.7	The gas flow measurement screen.....	44
8.8	How to use an anemometer (optional).....	45
8.9	How to use a pitot tube (optional).....	48
8.10	How to use an H <sub>2</sub> S filter (optional).....	49
8.10.1	Cross gas effects on chemical cells.....	49
8.10.2	Cross-gas effects on methane, carbon dioxide and oxygen.....	50
8.11	How to use a temperature probe (optional).....	52
8.12	How to identify a borehole using the GPS feature (optional).....	53
8.13	Taking gas and flow measurement.....	56
<b>9.0</b>	<b>CALIBRATION.....</b>	<b>56</b>
9.1	Calibration introduction.....	56
9.2	Frequency of calibration – best practice.....	57
9.3	Calibration gases.....	58
9.4	Calibration set-up.....	58
9.5	Calibration equipment.....	59
9.6	Gas analyzer.....	60
9.7	Calibration processes – best practice.....	60
9.7.1	Gas Check in fresh air.....	61
9.7.2	Calibration – mixtures 1, 2, & 3.....	62
9.8	Restore to factory.....	63
9.9	Calibration history.....	63
9.10	Calibration summary.....	63
<b>10.0</b>	<b>THE LANDTEC GAS ANALYZER MANAGER SOFTWARE (LSGAM).....</b>	<b>64</b>
10.1	LANDTEC System Online Users.....	64
10.2	Offline Users.....	64
10.3	Installation with CD or Memory Stick.....	65
10.4	Start Up.....	66
10.5	Navigation.....	67
10.6	Connecting to the Instrument.....	68
10.7	Create a Project/Select a Project.....	69
10.7.1	ID Setup.....	70
10.7.2	Creating Comments.....	70
10.7.3	Creating ID's.....	71
10.7.4	Importing Data Field CS ID's.....	75
10.7.5	Create a New Project (ID's already in the instrument).....	75
10.7.6	Creating Site Questions.....	76



# GEM5000 Gas Analyzer

---

10.7.7	Working with Device ID's.....	78
10.7.8	Sending ID's to the Instrument.....	80
10.7.9	Clearing ID's or Deleting a Project.....	82
10.7.10	Clearing the Instrument Memory.....	84
10.7.11	Instrument Settings.....	85
10.7.12	Alarm Settings.....	86
10.7.13	Misc. Options.....	87
10.7.14	Units of Measurement.....	88
10.7.15	Downloading Readings.....	91
10.7.16	Clear Readings.....	93
10.7.17	Exporting Readings.....	94
<b>11.0</b>	<b>PROBLEM SOLVING .....</b>	<b>95</b>
<b>12.0</b>	<b>WARNING AND ERROR DISPLAY.....</b>	<b>95</b>
<b>13.0</b>	<b>SERVICE .....</b>	<b>96</b>
<b>14.0</b>	<b>WARRANTY POLICY .....</b>	<b>97</b>
<b>15.0</b>	<b>GLOSSARY OF TERMS .....</b>	<b>98</b>











# GEM5000 Gas Analyzer

## 1.0 Manual guidelines

### 1.1 Hazard warnings and safety symbols

	<p>Warning</p>	<p>Information in this manual that may affect the safety of users and others is preceded by the warning symbol.</p> <p>Caution - Failure to follow the correct information may result in physical injury which in some cases could be fatal. If the equipment is used in a manner not specified by the manufacturer, the protection provided by the equipment may be impaired.</p>
---	----------------	--

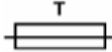
General product label symbols are listed as follows:

	<p>CE conformity-The CE-marking is the manufacturer's statement to the EU authorities that the product complies with all relevant CE-marking Directives.</p>		<p>If the CSA mark appears with the indicator "US" or "NRTL" it means that the product is certified for the U.S. market, to the applicable U.S. standards.</p>
	<p>VDE mark is a symbol for electrical, mechanical, thermal, toxic, radiological and other hazards.</p>		<p>Separate collection, handling and disposal for waste electrical and electronic equipment and its components.</p>
	<p>Electric shock warning.</p>		<p>Refer to operators manual.</p>
	<p>Double insulated construction - does not require an Earth.</p>		<p>Specific marking of explosion protection (ATEX only).</p>
<p>II 2G</p>	<p>Equipment group and category. G = gases; the type of explosive atmosphere.</p>		<p>IECEX licenced mark (IECEX only).</p>
	<p>Fuse.</p>		<p>Equipment for indoor use only.</p>

### 1.2 Notes

Important/useful information and instructions are shown clearly throughout the manual in a note format. For example:

✎ Note: For further information please contact Technical Support at (800) 968-2026 or email [landtec\\_support@qedenv.com](mailto:landtec_support@qedenv.com)

# GEM5000 Gas Analyzer

---

## 2.0 Introduction

This manual explains how to use the GEM5000 landfill gas analyzer. The GEM5000 has additional functionality to the GA5000 gas analyzer. The GA5000 measures gas concentrations only, whereas the GEM5000 measures flow and gas concentrations. The GEM5000 measures flow and calculates the calorific values of the gas as well as being a useful tool for balancing the gas field. The GEM5000 gas analyzer may be used to monitor, calculate, adjust and record the flow at each monitoring point.

This instrument may also be used in GA5000 mode of operation if required. The operator may change the analyzer between a gas extraction monitor (a GEM5000 gas analyzer) or a landfill gas analyzer (a GA5000 gas analyzer). The mode of operation can be changed from the 'Special Action' menu. Please refer to section '8.0 – Taking Readings' for further instruction.

The 5000 series of gas analyzers complies with Part 15 of the FCC Rules. Operation is subject to the following two conditions:

- 1) This device may not cause harmful interference.
- 2) This device must accept any interference received, including interference that may cause undesired operation.

## 2.1 Safety instructions

<p> <b>Warning</b></p>	<p>The 5000 series of gas analyzers can be used for measuring gases from landfill sites and other sources as described in this manual.</p> <p>The operator may be exposed to harmful gases during the use of the instrument. Inhaling these gases may be harmful to health and in some cases may be fatal.</p> <p>It is the responsibility of the user to ensure that he/she is adequately trained in the safety aspects of the gases being used and appropriate procedures are followed. In particular, where hazardous gases are being used the gas exhausted from the analyzer must be piped to an area where it is safe to discharge the gas.</p> <p>Hazardous gas can also be expelled from the instrument when purging with clean air.</p> <p>The instrument has been designed to be used in explosive atmospheres as defined by the classification. The instrument can be configured to measure low levels of several gases, but may not be certified for use in potentially explosive atmospheres of these gases. It is the responsibility of the operator to determine the protection concept and classification of equipment required for a particular application and whether these gases create a potentially explosive atmosphere.</p>
---	---

 **Note:** Gas analyzers are a sensitive piece of scientific equipment, and should be treated as such. If the equipment is used in a manner not specified by the manufacturer, the protection provided by the instrument may be impaired.

# GEM5000 Gas Analyzer

---

## 2.2 Instructions for safe use

### For ATEX and IECEx the 5000 series of gas analysers are certified to Hazardous Area Classification

**Ex II 2G Ex ib IIA T1 Gb (Ta = -10°C to +50°C)**

It is vital instructions are followed closely. It is the responsibility of the operator to determine the protection concept and classification required for a particular application.

(Reference European ATEX directive 2014/34/EU)

The following instructions apply to equipment covered by certificate numbers SIRA 11ATEX2197X and IECEx SIR 11.0089X:

- The equipment may be used with flammable gases and vapours with apparatus group IIA and temperature class T1.
- The equipment can contain gas sensing heads for the detection of particular gases. The inclusion of a sensor does not infer that the equipment is suitable for the use of gases with a temperature class of less than T1.
- The equipment is only certified for use in ambient temperatures in the range -10°C to +50°C and should not be used outside this range.
- The equipment must not be used in an atmosphere of greater than 21% oxygen.
- Repair of this equipment shall be carried out in accordance with the applicable code of practice.
- When used in a hazardous area only use GF5.2 temperature probe (SIRA 11ATEX2197X and IECEx SIR11.0089X). For connector C, the GF5.4 anemometer (BVS 04ATEXE194) for use with ATEX only. The analyser should not be connected to any other devices in the hazardous area including the GF-USB lead (connector A) or GF3.9 battery charger (connector B) supplied with the analyzer.

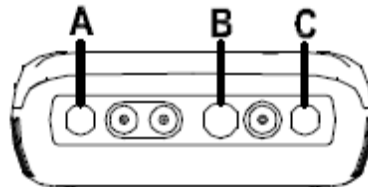

**Do not charge, recharge or open in a potentially explosive atmosphere.  
In hazardous area only use "Temperature Probe GF5.2" in Connector B.  
Connector C (Uo=10V,Io=5mA,Po=50mW,Ci=0,Li=0,Co=100uF,Lo=1000mH),  
Connector B (Uo=5V,Io=6mA,Po=7mW,Ci=0,Li=0,Co=100uF,Lo=1000mH)**

**MAXIMUM NON-HAZARDOUS SUPPLIES:  
Connector A - Um=6V Connector B - Um=10.1V**

- The safe area apparatus that is to be connected to the USB Port shall be a Safety Extra Low Voltage (SELV) or Protective Extra Low Voltage (PELV) circuit.
- Only a Geotechnical Instrument battery pack part number 20087 or 2011113 is permitted as a replacement. This battery pack is not field replaceable and shall only be changed in a safe area by QED personnel.
- Only Battery Charger type GF3.9 shall be used to recharge the batteries via Connector 'B'.
- If the equipment is likely to come into contact with aggressive substances, e.g. acidic liquids or gases that may attack metals, or solvents that may affect polymeric materials, then it is the responsibility of the user to take suitable precautions, e.g. regular checks as part of routine inspections or establishing from the material's data sheet that it is resistant to specific chemicals that prevent it

# GEM5000 Gas Analyzer

from being adversely affected, thus ensuring that the type of protection is not compromised.

- The relative pressure range is +/-500 mbar. Note, however, that the input pressure should not exceed +/- 500 mbar relative to atmospheric pressure and the output pressure should not exceed +/- 100 mbar relative to atmospheric pressure.

**For CSA (Canada) the 5000 series of gas analysers are certified to Hazardous Area Classification**

**CLASS 2258 03** - PROCESS CONTROL EQUIPMENT - Intrinsically Safe and Non-Incendive Systems - For Hazardous Locations



**Ex ib IIA:**

Model GA 5000, GEM 5000 and BIOGAS 5000 Methane Detectors; portable, battery powered with non-field-replaceable Battery Pack P/N 20087 or 2011113; intrinsically safe and providing intrinsically safe circuits (“[ib]” for Zone 1) to Model GF5.2 Temperature Probe (Connector B) and with entity output parameters as tabulated below; Temperature Code T1; -10 °C ≤ Tamb. ≤ +50°C.

Connector	Entity Parameters						
	Uo (V)	Io (mA)	Po (mW)	Co (uF)	Lo (mH)	Ci (uF)	Li (mH)
B	5.0	6	7	100	1000	0	0
C	10.0	5	50	100	1000	0	0

⚠ Note: This device has been investigated for electrical safety features only.

**For CSA (USA) the 5000 series of gas analysers are certified to Hazardous Area Classification**

**CLASS 2258 83** - PROCESS CONTROL EQUIPMENT - Intrinsically Safe and Non-Incendive Systems – For Hazardous Locations - CERTIFIED TO U.S. STANDARDS



**AEx ib IIA:**

Model GA 5000, GEM 5000 and BIOGAS 5000 Methane Detectors; portable, battery powered with non-field-replaceable Battery Pack P/N 20087 or 2011113; intrinsically safe and providing intrinsically safe circuits (“[ib]” for Zone 1) to Model GF5.2 Temperature Probe (Connector B) and with entity output parameters as tabulated below; Temperature Code T1; -10 °C ≤ Tamb. ≤ +50°C.

Connector	Entity Parameters						
	Uo (V)	Io (mA)	Po (mW)	Co (uF)	Lo (mH)	Ci (uF)	Li (mH)
B	5.0	6	7	100	1000	0	0
C	10.0	5	50	100	1000	0	0

⚠ Note: This device has been investigated for electrical safety features only.

## 2.3 MCERTS

MCERTS is the UK Environment Agency's Monitoring Certification Scheme. The scheme provides a framework within which environmental measurements can be made in accordance with the Agency's quality requirements. The scheme covers a range of monitoring, sampling and inspection activities.

MCERTS promotes public confidence in monitoring data and provides industry with a proven framework for choosing monitoring systems and services that meet the Environment Agency's performance requirements.

The Environment Agency has established its Monitoring Certification Scheme (MCERTS) to deliver quality environmental measurements. The MCERTS product certification scheme provides for the certification of products according to Environment Agency performance standards, based on relevant CEN, ISO and national standards.

MCERTS certified instruments have been tested by an independent body to ensure that they meet certain performance requirements. In addition the manufacturer of an MCERTS product is regularly audited to ensure that the performance requirements of the certification are being continually met.

The 5000 series of gas analyzers have been certified to Version 3.1 of the 'Performance Standards for Portable Emission Monitoring Systems'.

## 2.4 CIRIA

The CIRIA guideline 'Assessing the risks posed by hazardous ground gases to buildings' proposes that gas concentrations and flow rates should be monitored.

As an example methodology, they suggest using a gas analyser to first measure flow and pressure and then afterwards to measure gas concentration.

The logging profile option offers frequency of data to be collected within a timed period which, in return, identifies a gas profile of the sample point being monitored, information about whether the sample point is performing correctly, when the peaks occur and whether air is drawn in after a certain period. This logging option is available on firmware software version 1.6.5

Versions of the GA5000 analyzer range with internal flow on firmware version 1.6.5 and above have the ability to take measurements according to the CIRIA guidelines, while still allowing other users to take the measurements as before.

# GEM5000 Gas Analyzer

---

## 3.0 The GEM5000 Gas Analyzer

### 3.1 The GEM5000



The GEM5000 gas analyzer is designed to monitor landfill gas extraction systems.

#### Benefits:

- Allows balancing of gas extraction site.
- Maximize power generation from site.
- Field proven.
- Standardizes monitoring routines.
- Easy transfer of data.
- GPS for compliance.

#### Features:

- ATEX certified.
- MCERTS certified.
- H<sub>2</sub> compensated CO.
- Calculates flow (m<sup>3</sup>/hr) and calorific value (kW or BTU).
- Technician log-in.
- Event log.
- Two instruments in one (GA and GEM mode).
- Measures static and differential pressure.
- Simultaneous display of gases.
- Storage of changes in set-up of gas field.
- Data logging.

#### Applications:

- Gas extraction fields.
- Flare monitoring.
- Landfill sites.

# GEM5000 Gas Analyzer

---

## 3.2 GEM5000 standard product



### Reference:

- A Hard carry case
- B In-line water trap tubing & filter
- C Gas analyser instrument
- D H2S filter (optional – if the compensated CO cell is fitted)
- E 5000 series safety manual
- F Mains battery charger and adaptors:
  - UK
  - Europe
  - US
  - Australia



## 4.0 GEM5000 Optional Products and Accessories

### 4.1 Optional products

The GEM5000 gas analyzer has a number of optional products for purchase which enhance the usability and enable further analysis of data and reading information.

✍ Note: For more information on the features listed in this section please contact Sales at (800) 624-2026 or email [info@qedenv.com](mailto:info@qedenv.com)

#### 4.1.1 Pitot tube (optional)

The GEM5000 gas analyzer enables the use of a pitot tube to aid accurate flow measurement. The pitot tube is used for gas extraction systems and the pressure readings are taken in mbar. High gas flow is calculated in the analyzer in m<sup>3</sup>/hr (metres cubed per hour).

#### 4.1.2 Orifice plate (optional)

QED recommends the use of orifice plates as good practice when using the GEM5000 gas analyzer, enabling repeatability in flow measurement via a fixed method. Contact Sales at (800) 624-2026 or email [info@qedenv.com](mailto:info@qedenv.com) if the use of Orifice plates is required.

#### 4.1.3 Temperature probe (optional)

The GEM5000 gas analyzer has the facility to automatically display and record the borehole temperature via an optional temperature probe.

When a temperature probe is fitted the temperature reading will be displayed on the 'Main Gas Read Screen' and recorded with all other data.

✍ Note: Temperature probes with an Ex label are part of the GEM5000 Ex certification SIRA 11ATEX2197X and IECEx SIR11.0089X, and therefore certified for use under the same conditions as the analyzer.

#### 4.1.4 Anemometer (optional)

The GEM5000 gas analyzer has the facility to automatically display and record high flow via an optional anemometer probe. It is designed to plug into the instrument and instantly provide a flow indication. An anemometer probe adds flow measurements to the professional reporting ability of the GEM5000 range along with gas concentrations, pressure and temperature.

The anemometer has a simple connection, a narrow diameter measurement head (11mm), a wide temperature operating range (up to 80°C) and indicates flows up to 40 m/sec.

When an anemometer probe is fitted to the analyzer the flow will be displayed in the 'Main Gas Read Screen' and recorded with all other data.

Flow can be measured in either m/s (gas velocity) or m<sup>3</sup>/hr (volume flow rate). In order to calculate the volume flow rate the pipe diameter will need to be entered into the instrument, either manually or via the Landtec Systems Gas Analyser Manager, (LSGAM), software.

✍ Note: The anemometer probe is ATEX certified for use in a potentially explosive atmosphere under Ex certificate BVS 04ATEXE194.

# GEM5000 Gas Analyzer

---

## 4.1.5 H<sub>2</sub>S filter (optional)

The GEM5000 gas analyzer has the capability to use an H<sub>2</sub>S filter and is required as standard if the compensated CO cell is fitted and configured at the time the instrument is manufactured. H<sub>2</sub>S gas can have a cross-gas effect on the CO reading. By using a filter, the H<sub>2</sub>S is removed from the gas sample, therefore providing a more accurate CO reading.

The filter only needs to be used when you are trying to get rid of any possible cross gas effects H<sub>2</sub>S might have on other gases. Do not use the filter on all boreholes.

## 4.1.6 Landtec Systems Gas Analyzer Manager – LSGAM

Landtec Systems Gas Analyzer Manager (LSGAM) enables the operator to maximize the operation of the gas analyzer. It enables direct communication with the unit, features a simple upload and download facility and is fully compatible with the latest Microsoft™ operating systems.

### Features:

- Organization and transfer of borehole IDs and readings to and from the gas analyzer.
- Configuration of the gas analyzer.
- Flexible grouping of the IDs.
- Structured organization of transferred data.
- Automatic detection of instrument type and available options.
- Secure data mode to prevent tampering.
- First time set-up wizard.
- Enable flow measurements for GEM5000 gas analyzers.

## 4.1.7 GPS (optional)

An optional GPS feature is available for the GEM5000 gas analyzer. It enables the site engineer to automatically locate borehole IDs using GPS satellite signal from predefined borehole IDs uploaded from LSGAM or set on the analyzer when out in the field prior to taking a reading. The GPS reading data is stored for each measurement reading providing an audit trail confirming that a reading was taken.

## 4.1.8 Bluetooth

The analyzers are fitted with a Bluetooth receiver which enables the operator to download readings and upload IDs without the need to connect the analyzer to a PC via a USB cable.

# GEM5000 Gas Analyzer

## 5.0 GEM5000 Instrument Features

### 5.1 Physical characteristics of the instrument panel

Front view:



Reference:

- A Main Gas Read Screen
- B Soft-keys
- C Backlight Key
- D Menu Key
- E Pump key
- F LED Light
- G On/Off Key
- H Assistance key
- I Enter Key
- J Scroll up key
- K Scroll down key
- L Key 0 - Space key

Back view:



Reference:

- M Model Number
- N Serial number
- O Part number
- P Certificate number
- Q Recalibrated date

# GEM5000 Gas Analyzer

---

## 5.2 Analyzer features and keys

A	Main Gas Read Screen	Start and end screen when using the instrument.
B	Soft-keys	The function of the three 'soft-keys' on the front of the instrument panel is determined by menu options taken. Functions vary from screen to screen.
C	Backlight key	Enables the operator to turn the backlight on/off on the analyzer display panel.
D	Menu key	Press the 'Menu' key to view and maintain User, Device and Operation settings.
E	Pump key	Press the 'Pump' key to start or stop the pump.
F	LED light	LED power light is visible on the front of the analyzer when the instrument is powered on.
G	On/Off key	Press the 'On/Off' key for 2 seconds to switch the instrument on and off.
H	Assistance key	Press for on-screen assistance and help.
I	Enter key	Use to accept changes, options, user inputted answers etc.
J	Key 2 – Page Up	Also 'Key 2'. Press scroll up to view further information on the instrument screen.
K	Key 8 – Page down	Also 'Key 8'. Enables the operator to scroll down to display more information.
L	Key 0 – Space key	Also 'Key 0'. Press to enter a space when entering text on the instrument screen.
M	Model Number	Instrument model type identification.
N	Serial Number	Unique identification for the instrument. Verification of the serial number will be required if Technical Support assistance is needed.
O	Part Number	Manufacturer's part number.
P	Certification Number	Displays instrument certification information.
Q	Recalibrated Date	The date displayed is the date the instrument is due to be calibrated.

# GEM5000 Gas Analyzer

---

## 5.3 Instrument connection points

Top view:

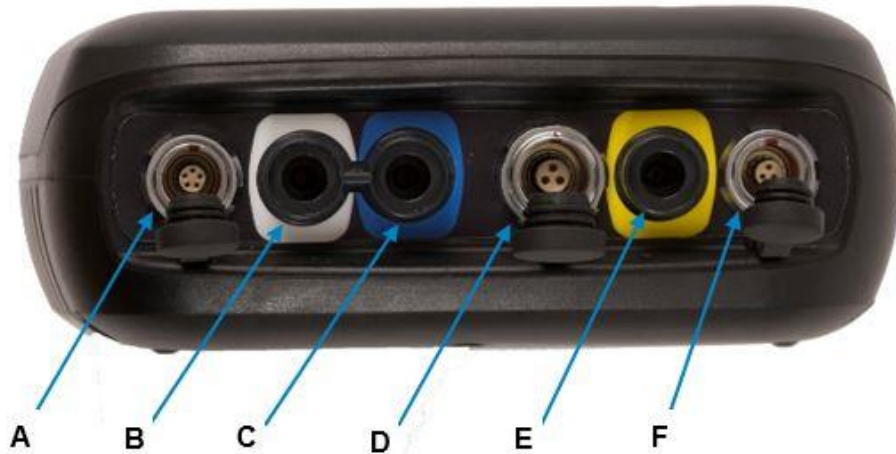

Ref:	Connection Point:	Function:
A	Connector A	Attach the USB cable for PC-to-analyzer connectivity.
B	Inlet Port & Static Pressure Port (White port)	Attach the sample tube to take a gas sample. Also used to measure the static pressure.
C	Differential Pressure Port (Blue port)	Attach the sample tube to measure differential pressure.
D	Connector B	Attach the temperature probe and also used to attach the mains charger to the analyzer for charging.
E	Gas Outlet Port (Yellow port)	The gas outlet port is the point at which the sample gas is expelled. Tubing may also be attached to the port.
F	Connector C	Attach the anemometer.

## 6.0 General Operational Instructions

### 6.1 Switching the instrument on

- 1) To switch on the analyzer, press and hold the 'On/Off' key. The Landtec logo will display followed by the instrument warm up.
- 2) Following the instrument warm up, the 'Date and Time' screen is displayed prompting the technician to set the date and time and required format.
- 3) When complete, select the soft-key to 'Exit' and the 'Power On Self-test' screen is displayed followed by instrument status. Instrument status displays the instruments service due date, serial number, options, service scheme and software version. Text will also display stating 'Self-test complete'.
- 4) Select the soft-key 'Next' to move onto the next screen and the 'Technician Login' screen is displayed.
- 5) Use the cursor keys to move through the list of ID's. Select either the required 'Technician ID' from the list followed by the soft-key 'Accept', or select 'Default' followed by the soft-key 'Accept' to continue to the 'Main Gas Read Screen'.

⚠ Note: The selected technician ID is displayed at the top left corner of the Main Gas Read Screen.

#### 6.1.1 Power on self-test

When switched on, the read-out will perform a pre-determined self-test sequence. During this time many of the analyzer's functions are tested, including:

- General operation
- Gas flow measurement
- Calibration
- Battery charge level

During the self-test the following information is also displayed:

- Manufacturer's service due date
- The last gas check date
- Software version programmed
- Date format
- Serial number
- Operating language
- The currently enabled sales option

⚠ Note: The self-test should only be done with the analyzer sampling fresh air.













### 6.2 Switching the instrument off

- 1) To switch off the analyzer, press and hold the 'On/Off' key, at which point a clean air purge will be carried out and the instrument will then switch off.
- 2) If for any reason the analyzer 'locks up' and will not switch off in this manner, press and hold the 'On/Off' key for 15 seconds; this will force the instrument to switch off.

# GEM5000 Gas Analyzer

## 6.3 Instrument status icons

The following icons may be displayed on the instrument screen:

Icon	Description	Icon	Description
	<b>Battery charge state</b> Gives the operator an estimation of the battery charge state. For example 100% gives about 8 hours use in the field and 50% would mean that there is approximately 4 hours battery life remaining.		<b>Battery charge state</b> Indicates less than 2 hours of charge remaining.
	<b>Pump status</b> This icon is displayed along with a counter showing the pump run-time. This counts down where the operator has specified the pump run-time; if not it counts up; the icon turns red when stalled.		<b>Pump stalled</b> This icon is displayed when the pump stalls. The instrument's gas inlet (or outlet) may be blocked. This warning is most commonly caused by a water-logged or dirty sample filter. Change the sample filter and check for obvious blockages in the sample tubes. Alternatively, a small amount of adjustment can be made to the low flow detection point to compensate for minor changes in the performance of the pump fitted to the instrument.
	<b>GPS signal strength</b> This icon shows the signal strength the analyzer's GPS module is able to provide. Full, okay and fair strength respectively.		<b>GPS failure</b> The GPS was unable to get a line of sight lock on enough satellites. Or, it may be that it hasn't had time to get a lock.
	This indicates when Bluetooth has been enabled. The color changes from gray to blue when connected.		<b>Language</b> This icon indicates the currently selected operating language. This can be changed via the main menu.
	<b>Data logging</b> This icon indicates that the data logging feature is in operation.		<b>Service overdue</b> This icon indicates that the analyzer is overdue for service
	<b>Legacy mode</b> This icon indicates that the analyzer is in legacy mode and hence is ready to connect to a PC.		<b>USB disabled</b> This icon indicates that the analyzer has reached a battery critical state, and hence has turned off its USB connectivity.

## 6.4 Instrument LED power states

When the instrument is powered on a LED power light is visible on the front of the analyzer, located above the 'On/Off' key. The following LED power light states are as follows:

<b>Steady yellow</b>	Unit turning on. This will extinguish when software has loaded correctly.
<b>Flashing (rapid)</b>	Unit is powering off.
<b>Flashing (slow)</b>	Power off is being delayed for purge/shutdown handling.
<b>Flashing yellow</b>	Unit is turning off due to power button being pressed.
<b>Flashing red</b>	Unit is turning off due to critically low battery.

✍ Note: Pressing and holding the power button for ~20s resets the analyser.

## 6.5 Changing between parameters

By default, the instrument displays the 'Main Gas Read Screen' (for gas measurement). The instrument will return to this screen after power on or when returning from the menus. The 'Scroll' keys can be used to switch to another measurement screen.

## 6.6 Entering data

During normal operation the operator may be prompted to enter data or information via the keypad, i.e. entering an ID code or setting an alarm level.

When entering data into the instrument all fields are fixed format and are populated from the left.

### Text:

Entering text uses similar multi-tap functionality as a mobile phone. Key the numeric/alpha key pad the required number of times to select the appropriate letter. To key numeric data continue to press the numeric/alpha key until the required number is displayed.

### Numeric data:

To enter a new date 09/15/16 the operator would type in 091516 using the numeric keypad in the following sequence:-

```
* 0_/_/_/___  
* 09/_/_/___  
* 09/1_/_/___  
* 09/15/_/___  
* 09/15/1_/_  
* 09/15/16
```

Press the 'Enter' key to confirm/accept data keyed.

Any mistakes can be corrected using the soft-key 'Delete' which will delete the last digit typed. Alternatively, the sequence can be retyped before the 'Enter' key is pressed and the existing numbers will be pushed off the screen.

✍ Note: The instrument will not allow invalid data to be entered; this should be deleted and re-entered.



# GEM5000 Gas Analyzer

## 6.7 Instrument main gas read screen

The 'Main Gas Read Screen' is considered to be the normal operating screen and all operations are carried out from this starting point.

The actual data shown on this display will depend on the version of the instrument and the options that have been selected.

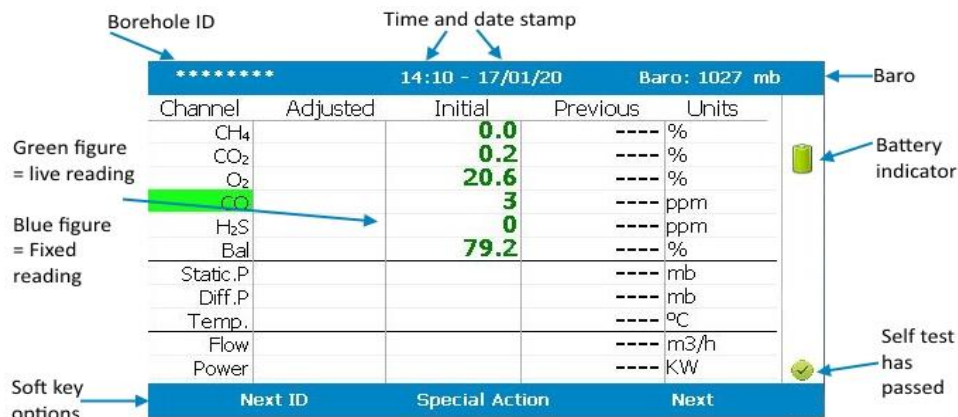

Main Gas Read Screen

You can also press key 2 and access a zoomed version of the main read screen, once you have entered this mode, simply use keys 4 and 6 to switch between the gases and pressures. Examples of both screens can be seen below:



Zoomed version

## 6.8 Storage

The analyzer should not be exposed to extreme temperature. For example, do not keep the analyzer in a hot car. When not in use, analyzers should be kept in a clean, dry and warm environment, such as an office. Protect the analyzer with either the soft carry case or store in the hard carry case provided with the instrument.

The instrument should be discharged and fully charged at least once every four weeks, regardless of indicated charge state.

## 6.9 Battery/charging

The battery used in the 5000 series of gas analyzers is nickel metal hydride and manufactured as a pack from six individual cells. This type of battery is not so susceptible to the top-off charging 'memory effects' as nickel cadmium batteries, although it is not recommended that the unit is given small top-off charges.

**Note:** To reach optimum charge, it is recommended that the instrument is switched off when being charged and remains switched off during the charging process.

# GEM5000 Gas Analyzer

A full charge will take approximately 4 hours from a fully discharged battery.

 <b>Warning</b>	<p>The battery charger is NOT covered by the Ex certification. The battery must be charged only in a safe area.</p>
--	---

The battery charger is intelligent and will indicate when the unit is charging and charged.

The instrument must be charged ONLY using the battery charger supplied with the instrument. The battery charger supplied is intended for indoor use only. Please ensure adequate ventilation while charging. Typically, a fully charged battery will last 7-8 hours. A quick 30 minute charge can be used to give approximately one hours use in the field but this may shorten the battery life. Temperature can dramatically affect the battery life; please take this into account when estimating battery life.

⚡ Note: Connect the charger to the mains attaching the appropriate adaptor.

## Power supply front and back drawing:

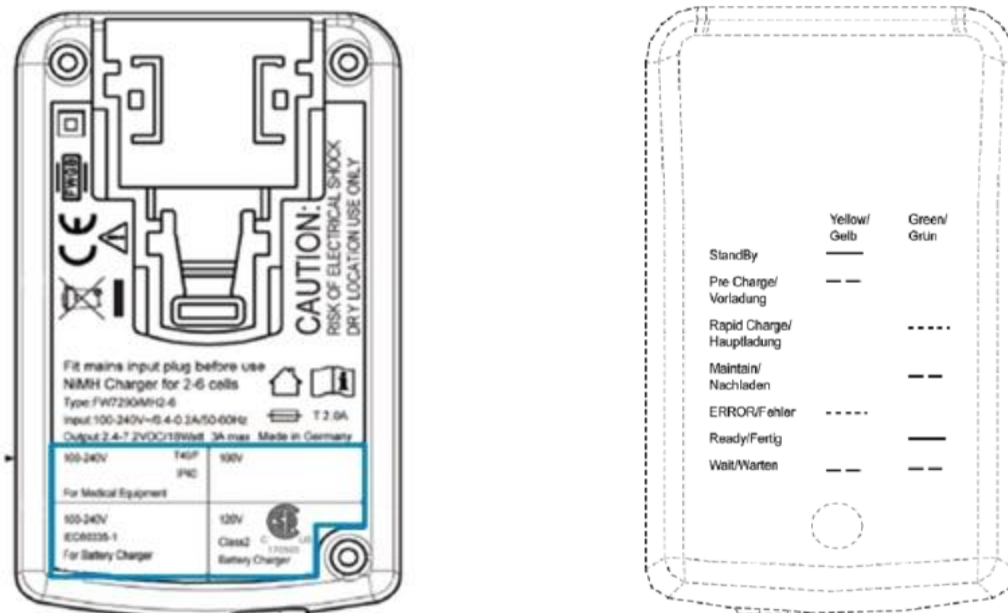

Charger: Input voltage: 100-240V AC +/- 10%  
 Input frequency: 50-60Hz +/- 10%  
 Input current: 0.4A@100VAC .. 0.2A@240VAC

Output voltage: 10.1VDC max  
 Output current: 1.5A max

⚡ Note: This charger has been internally restricted to 1.5A

## 6.10 Cleaning instructions

Do NOT use any cleaning agents to clean the analyzer or battery charger as they may have an adverse effect on the safe use of these devices.

# GEM5000 Gas Analyzer

## 6.11 Memory

The analyzer's memory is stored in a readings and configuration database. The analyzer will prompt when its memory is full, and you will not be able to store any further readings. Please download your readings via LSGAM or the Basic Download Software and then clear the memory.

✍ Note: The analyzer should never be stored for prolonged periods with valuable data in its memory. It is advisable to download all readings to LSGAM at the end of each day's monitoring. To clear the memory, please refer to the LSGAM operating manual.

## 6.12 Warning and error codes

When switched on the instrument will perform a predetermined self-test sequence taking approximately ten seconds. During this time many of the instrument's working parameters and settings are checked. If any operational parameters are out of specification or if the pre-programmed recommended calibration/service date has passed, errors or warnings may be displayed.

✍ Note: For further information please refer to section '10.0 Problem Solving'.

## 7.0 Operator Settings

### 7.1 Menu key



The 'Menu' key enables the operator to select options to set up specific parameters and perform operational tasks prior to sample readings being taken or to view data and information stored in the instrument.

- 1) Select the 'Menu' key on the front of the analyzer and the following screen is displayed:



- 2) Press the relevant numeric key on the analyzer keypad to select the required option.
- 3) To exit this menu, select the soft-key 'Exit' on the front of the analyzer and the operator is returned to Main Gas Read Screen.

## 7.2 Operation settings

To access the 'Operation settings' menu, select the 'Menu' key on the front of the analyzer. The following menu is displayed:



### 7.2.1 Timers



Data Logging

The timers function enables the operator to set standard purge times and set auto-power off if the unit is untouched for the period of time specified.

- 1) Select 'Key 1 – Timers' and the following screen is displayed:



- 1) Select 'Key 1' to edit the purge time. Enter the 'Pump Running Time' in seconds; this is the length of time you wish to run the pump to draw the sample, e.g. key in 030 then press the 'Enter' key to accept.
- 2) Select 'Key 2' to edit the auto power off time. Enter the 'Auto power off' in minutes; the instrument will automatically power off to preserve the battery life after the specified time if no activity has occurred on the instrument. Press the 'Enter' key to accept.
- 3) Select the soft-key 'Exit' key to exit the screen and return to the 'Operation settings' menu.

**Note:** Setting the purge time and auto power off functions to zero, disables the option. It is not recommended to reduce the purge time to below 30 seconds.

# GEM5000 Gas Analyzer

## 7.2.2 Gas Check



Gas Check

This option displays the 'Gas Check' menu and enables the operator to zero and span the gas channels on the instrument. Historical/previous gas checks data can also be viewed and factory settings can be restored.

- 1) Select the 'Menu' button on the front of the analyzer to display the 'Device Settings' menu. Press the soft key to display 'Operation Settings'.
- 2) Select 'Key 2 - Gas Check' and the following menu is displayed:



- 3) For more information about the Gas Check Menu please refer to section 9.0 - Calibration.
- 4) Select soft-key 'Exit' to exit operation settings and return to the main screen.

## 7.2.3 View data



View Data

This option enables the operator to view the readings collected and stored on the instrument. Readings may be downloaded to the optional LSGAM software if further analysis is required.

- 1) Select the 'Menu' button on the front of the analyzer to display the 'Device Settings' menu. Press the soft-key to display 'Operation Settings'.
- 2) Select 'Key 3 - View Data' and the following screen is displayed:

Gas	Unit	Value	Gas	Unit	Value
CH <sub>4</sub>	(%)	23.1	PEAKCH4	(%)	23.1
CO <sub>2</sub>	(%)	0.1	PEAKCO2	(%)	0.1
O <sub>2</sub>	(%)	17.0	MINO2	(%)	17.0
CO	(ppm)	0	SysP	(mb)	0.00
H <sub>2</sub>	(ppm)	----	Baro	(mb)	982
H <sub>2</sub> S	(ppm)	2	Temp	(°C)	----
Bal	(%)	59.7	Anemo	(m/s)	----
			Flow	(m <sup>3</sup> /h)	----

# GEM5000 Gas Analyzer

- 3) Toggle through the reading by selecting 'Key 4 – Scroll left' and 'Key 6 – Scroll right' on the analyzer. Select 'Key 2 – Page up' and 'Key 8 – Page down' to page through the auxiliary channels listed.
- 4) Select the soft-key 'Filter' to filter the data by sample point ID, or specify before or after date. Press the soft-key 'Exit' to exit the filter menu and return to the 'View Data' screen.



- 5) Select the soft-key 'Delete' followed by the appropriate soft-key to delete a single reading or all filtered readings. Press soft-key 'Cancel' to cancel the deletion request.
- 6) Select the soft-key 'Exit' to exit the view data screen.

## 7.2.4 Set alarms



Set Alarms

This option enables the operator to define the conditions for which an alarm/target will be triggered. These conditions apply to the general operation of the instrument and are not ID specific. A summary of the alarm settings can be found in 'Key 3 – Summary'.

### Types of alarms

**Common Alarms** – Are non-ID specific alarms which apply to all the readings taken with the analyzer.

**ID specific alarms** – Are ID specific, i.e. they will only trigger when a certain Id is being used.

**Tuning/targets** – You can also set targets for your gas channels; these will highlight gas channels green as oppose to when they alarm (yellow). These can be common or ID specific.

### Setting up alarms/targets

- 1) Select the 'Menu' button on the front of the analyzer to display the 'Device Settings' menu. Press the soft key to display 'Operation Settings'.

# GEM5000 Gas Analyzer

- 2) Select 'Key 4 – Set Alarms' and the following menu is displayed:



The screenshot shows the 'Alarms Summary' screen with the title '12:57 - 04/05/16' and 'Common'. It contains a table with columns 'Channel', 'Alarm', 'Low Limit', and 'High Limit'. The table lists five gas channels: CH<sub>4</sub> (%), CO<sub>2</sub> (%), O<sub>2</sub> (%), CO (ppm), and H<sub>2</sub>S (ppm). All are set to 'Disabled' with '--' for limits. A '0 Disable All' option is at the bottom left. Navigation buttons 'Initial', 'ID Alarms', and 'Exit' are at the bottom.

Channel	Alarm	Low Limit	High Limit
1 CH <sub>4</sub> (%)	Disabled	--	--
2 CO <sub>2</sub> (%)	Disabled	--	--
3 O <sub>2</sub> (%)	Disabled	--	--
4 CO (ppm)	Disabled	--	--
5 H <sub>2</sub> S (ppm)	Disabled	--	--

- 3) Select the corresponding key to select the gas for which you wish to set an alarm/target trigger for, followed by 'Key 1' to change the trigger condition of an alarm.
- 4) To manually adjust the alarm/target set press (<) 'Key 4 – Scroll left' or 'Key 6 – Scroll right' (>) and enter the trigger value. Once you are happy, press the middle soft key for 'save'.
- 5) For pressure, temperature and flow alarms, press the left soft key for 'Secondary' and then select the corresponding key to select the channel for which you wish to set an alarm trigger for, followed by 'Key 1' to change the trigger condition of an alarm/target. Once you are happy, press the middle soft key for 'save'.



The screenshot shows the 'Alarms Summary' screen with the title '12:57 - 04/05/16' and 'Common'. It contains a table with columns 'Channel', 'Alarm', 'Low Limit', and 'High Limit'. The table lists six channels: SysP (mb), Diff.P (mb), StaticP (mb), Temp (°C), Flow (m<sup>3</sup>/h), and (mK). All are set to 'Disabled' with '--' for limits. A '0 Disable All' option is at the bottom left. Navigation buttons 'Initial', 'ID Alarms', and 'Exit' are at the bottom.

Channel	Alarm	Low Limit	High Limit
1 SysP (mb)	Disabled	--	--
2 Diff.P (mb)	Disabled	--	--
3 StaticP (mb)	Disabled	--	--
4 Temp (°C)	Disabled	--	--
5 Flow (m <sup>3</sup> /h)	Disabled	--	--
6 (mK)	Disabled	--	--

- 6) To disable all alarm settings select key 0 – 'Disable All'

 Note: ID specific alarms cannot be added/edited on the analyzer, to add/edit ID specific alarms, please use the optional LSGAM Software.

## 7.2.5 Adjust flow fail



This option enables the operator to adjust the flow fail tolerance of the instrument, i.e. the operator can adjust the sensitivity for when the pump will stop operating on the presence of a blockage or low flow.

- 1) Select the 'Menu' button on the front of the analyzer to display the 'Device Settings' menu. Press the soft-key to display 'Operation Settings'.

# GEM5000 Gas Analyzer

- 2) Select 'Key 5 – Adjust Flow Fail' and the following screen is displayed:



- 3) Manual adjustment of the flow fail is available via this option and can be carried out with use of 'Key 4 – Scroll left' (<) less sensitive and 'Key 6 – Scroll right' (>) more sensitive.
- 4) Select the soft-key 'Save' to store the setting or select soft-key 'Exit' to exit the screen without saving the change.
- 5) The operator will return to the 'Operation settings' menu.

 Note: The default setting displays the bar in the centre. BEFORE altering this setting, please contact Technical Support at (800) 968-2026 or email [landtec\\_support@qedenv.com](mailto:landtec_support@qedenv.com)

## 7.2.6 Technician login



This option enables the operator to select or change a pre-defined technician login and all subsequent readings will be tagged with this Technician Login ID. The technician ID must already have been created using the LSGAM software and uploaded to the instrument.

- 1) Select the 'Menu' button on the front of the analyzer to display the 'Device Settings' menu. Press the soft key to display 'User Settings'.
- 2) Select 'Key 6 – Technician login' and the following screen is displayed:



- 3) Use the cursor keys to move throughout the list of IDs displayed; select the 'Enter' key to select choice of ID, default if no IDs are listed or soft-key 'Skip' to skip the selection.



# GEM5000 Gas Analyzer

4) The operator will return to the 'User settings' menu.

 Note: If no technicians are loaded via LSGAM, this section is skipped during start up and the 'Technician ID' icon is removed from the menu.

## 7.3 Device settings

To access the 'Device Settings' menu, select the 'Menu' key on the front of the analyzer to display the 'Operating Settings' menu followed by the soft-key to display 'Device Settings' menu. The following menu is displayed:



### 7.3.1 Date and time



This option enables the operator to set the instrument date and time or to receive and update the settings automatically from satellite signal.

- 1) Select the 'Menu' key on the front of the analyzer to display the 'Device Settings' menu followed by 'Key 1 – Date and Time' and the following screen is displayed:



- 2) Select 'Key 1 – Set Date' and key in the required date. Type the date using the numeric keypad. Press the soft-key 'Date Format' to toggle and select the required date format i.e. dd/mm/yy. Press the 'Enter' key to confirm and update the date setting.
- 3) Select 'Key 2 – Set Time' and key in the required time (hh:mm). Type the time using the numeric keypad and press the 'Enter' key to confirm the update.

# GEM5000 Gas Analyzer

---

- 4) The operator may also change the default time zone. Selecting the 'Key 4 Scroll-left' or 'Key 6 – Scroll right' to move through the different time zones. Press the 'Enter' key to confirm your default setting.
- 5) Select 'Key 3' to toggle between 'Manual Update' and 'Automatic Update' in order to choose how the date and time is set if updating from satellite signal.

Manual	Used to manually obtain and update the date and time from the satellite signal when requested. Select soft-key 'Set now' to set date and time from satellite when available.
Automatic	Used to automatically update the date and time received from the satellite signal when available. This option is only available when the GPS option is fitted to the analyser at the time of manufacture.

- 6) Select the soft-key 'Exit' to exit and return to the 'Device Settings' menu.

## 7.3.2 Bluetooth



This option enables the operator to set and utilize Bluetooth technology. This may be useful when downloading gas readings from the analyzer to the PC instead of connecting the analyzer to a PC via a USB cable. Bluetooth may also be used to transfer Site IDs to other 5000 series gas analyzers if required.

- 1) Select the 'Menu' key on the front of the analyzer to display the 'Device Settings' menu.
- 2) Select 'Key 2 – Bluetooth' and the following screen is displayed:



- 3) Enter the 'Pairing PIN' value when prompted by your computer for the device's pairing code.
- 4) Select soft-key 'Exit' to exit the screen and return to the 'Device Settings' menu.



# GEM5000 Gas Analyzer



Channel	ADC	Filt	Lin	Linz	Status
Ref (N/A)	10138	10134	+10134	+10134	✓
CH <sub>4</sub> (%)	-1	9944	0.2	0.2	✓
CO <sub>2</sub> (%)	5343	5343	2.6	2.6	✓
O <sub>2</sub> (%)	43511	43507	13.7	13.7	✓
S4Cell (0)					✗
CO (ppm)	32836	32836	0	0	✓
H <sub>2</sub> (ppm)	32833	32833	0	****	✓
H <sub>2</sub> S (ppm)	32866	32859	3	3	✓
PID (0)					✗

- 3) Select soft-key 'Next' to display the next screen, 'Previous' to return to the previous screen, or select soft-key 'Exit' to exit this screen and return to the 'Device Settings' menu.

✍ Note: For further information please contact Technical Support at (800) 968-2026 or email [landtec\\_support@qedenv.com](mailto:landtec_support@qedenv.com)

## 7.3.5 Navigation (optional)



Navigation is On

This option enables the operator to switch the 'GPS Navigation' functionality on or off. (This is optional and dependent upon purchasing the navigation option).

- 1) Select the 'Menu' key and the 'Device Settings' menu is displayed.
- 2) Select 'Key 5 - Navigation On' to switch on the GPS navigation functionality or 'Key 5 - Navigation Off' to switch the GPS navigation functionality off.



Navigation is On



Navigation is Off

✍ Note: For further information please refer to section '8.0 - Taking Readings'.

# GEM5000 Gas Analyzer

## 7.4 User settings

To access the 'User settings' menu, select the 'Menu' key on the front of the analyzer to display the 'Operating Settings' menu followed by the soft-key to display 'User Settings' menu. The following menu is displayed:



To exit the user settings menu select the soft-key 'Exit'.

### 7.4.1 Operating language



This option enables the operator to specify the operating language displayed for the instrument.

- 1) Select 'Key 1 - Operating Language' and the following screen is displayed:



# GEM5000 Gas Analyzer

---

Set the required language for the gas analyser by selecting the appropriate function key. Choose from, on the first page:

- |       |            |
|-------|------------|
| Key 1 | English    |
| Key 2 | Spanish    |
| Key 3 | French     |
| Key 4 | German     |
| Key 5 | Italian    |
| Key 6 | Portuguese |

Use the soft-keys to move to the next page for further language options, including simplified Chinese

- 2) To exit this option, select the soft-key 'Exit' and the operator is returned to the 'User Settings' menu.

## 7.4.2 Units of measurement



This option enables the operator to specify the default units of measurement for the instrument.

- 1) Select 'Key 2 – Units of Measurement' and the following screen is displayed:



- 2) To set the required units of measurement toggle and choose from the following:

- |       |             |                        |
|-------|-------------|------------------------|
| Key 1 | Temperature | °C<br>°F               |
| Key 2 | Flow        | scfm<br>m3/hr          |
| Key 3 | Measurement | Inches<br>Millimetres  |
| Key 4 | Pressure    | mb<br>"H2O             |
| Key 5 | Balance     | Balance<br>Residual N2 |

# GEM5000 Gas Analyzer

3) Select soft-key 'Exit' to exit this screen and return to the 'User Settings' menu.

## 7.4.3 ID selection

The ID selection screen allows the operator to scroll through all IDs, including those uploaded from LSGAM and added directly onto the instrument, and then make a selection. Detailed information regarding the currently selected ID, such as flow device type and pump runtime, are displayed below: -



By selecting 'Key 5' the operator can toggle between showing 30 IDs and showing 5 IDs with more detailed information relating to the chosen ID.



The technician can scroll between the IDs using the following keys on the instrument keypad:

- Two (2) and eight (8) move the selection up/down
- Four (4) and six (6) move the selection left/right on the list view
- One (1) and three (3) move the selection left/right a page in the list view only
- Seven (7) and nine (9) move the selection to first/last ID

Five (5) toggles between the 'ID with information' and 'ID list'  
Return/enter key selects the desired ID and proceeds to the navigation or reading screen.

If there are no IDs present the technician can either add a new ID or press the enter key on the instrument keypad to return to the previous screen.

# GEM5000 Gas Analyzer

---

Soft keys:

Left - Select 'No ID' and go to the purge/reading screen.

Center - Enabled when there is a list of IDs, allowing the technician to dynamically filter the IDs displayed in the list.

Right - Allows the technician to add a new ID to the instrument 'in the field'.

 Note: If your analyzer has firmware version v1.12 or greater, used IDs will have a strikethrough.

## Changing the sort order

By default the IDs are sorted in the order in which they were transferred to the instrument. To change the sort order between unsorted, sort by name or sorted by distance to travel press Key 0.



Sorted by original order (not sorted)



Sorted alphabetically



Sorted by distance to travel

 Note: Only available when GPS is enabled

For analyzers with firmware v1.12 and above:

- 1) Press the menu key
- 2) Press the middle soft key for 'User Settings'
- 3) Press key 3 - 'ID options'
  - a. Key 1 to change the sort order
  - b. Key 2 to change how the IDs are displayed
  - c. Key 3 to clear the line through on the current ID being used
  - d. Key 4 to remove the line through on all IDs





# GEM5000 Gas Analyzer

## 7.4.4 Routes

Using the optional LSGAM Software, you can upload a route. This is a predefined list of IDs that you can go through in an order. This feature is useful if you have a certain order to complete your IDS in.

Furthermore if your GA5000 has v1.12 or higher firmware it will strike through your IDs once you have used them.



 **Note:** If the analyzer is set to "route mode" (v1.12 and above), the filter box will no longer be there, as you cannot filter in this mode. It will be replaced by "Route" and the route name.

## 7.4.5 Adjust backlight



Adjust Backlight

This option enables the operator to adjust the backlight (brightness). Having this set to a darker setting will help preserve the battery power

- 1) Select 'Key 4 – Adjust Backlight' and the following screen is displayed:



- 2) Keys 4 and 6 can be used to adjust the brightness of the display screen.  
'Manual' disables the backlight timeout.
- 3) Select the soft-key 'Save' to store the setting or select soft-key 'Exit' to exit the screen without saving the change.
- 4) The operator will return to the 'User settings' menu.

# GEM5000 Gas Analyzer

Selecting 'Key 1' allows the operator to configure the dimmer settings from 'Auto Dim' to 'Auto Off' in order to help preserve power consumption when data logging.



This icon represents 'Auto Dim' – this enables the backlight idle timeout, which means the backlight will go dim after a specified period of inactivity. This will help save battery life.



This icon represents 'Auto Off' – this switches the backlight off, saving power.

*Note:* The manually set contrast setting is retained when the read-out is switched off and may require resetting when next switched on.

## 7.4.6 Adjust volume



Adjust Volume

This option enables the operator to adjust the volume for the internal speaker, for example the alarm tone. A lower setting will help preserve the battery power.

- 1) Select the 'Menu' button on the front of the analyzer to display the 'Device Settings' menu. Press the soft-key to display 'User Settings'.
- 2) Select 'Key 5 – Adjust Volume' and the following screen is displayed:

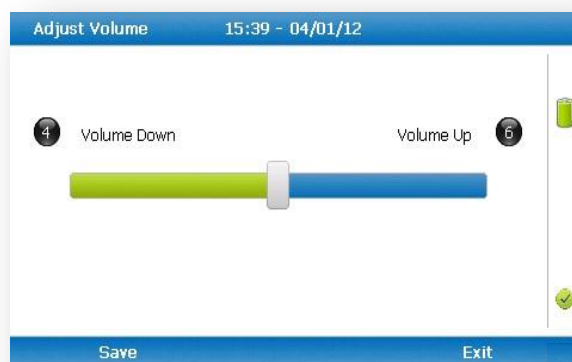

- 3) Manual adjustment of the volume is available via this option and can be carried out with use of 'Key 4 - Scroll left' (<) volume down and 'Key 6 - Scroll right' (>) volume up.
- 4) Select the soft-key 'Save' to store the setting or select soft-key 'Exit' to exit the screen without saving the change.
- 5) The operator will return to the 'User settings' menu.

## 7.4.7 User Prompts



This option enables the operator to either turn on or off the context-sensitive user prompts which are displayed during the gas sample process. The analyzer will have the user prompts on when it is first used, so if they are not required they can be switched off by selecting soft-key '6' and this will now be its default setting. Prompts can be switched back on at any time by returning to this menu and selecting soft-key '6'.

## 7.5 Exit menu

- 1) Press the 'Menu' button on the front of the analyzer to exit settings.

## 8.0 Taking Readings

### 8.1 Preliminary checks before taking readings (best practice)

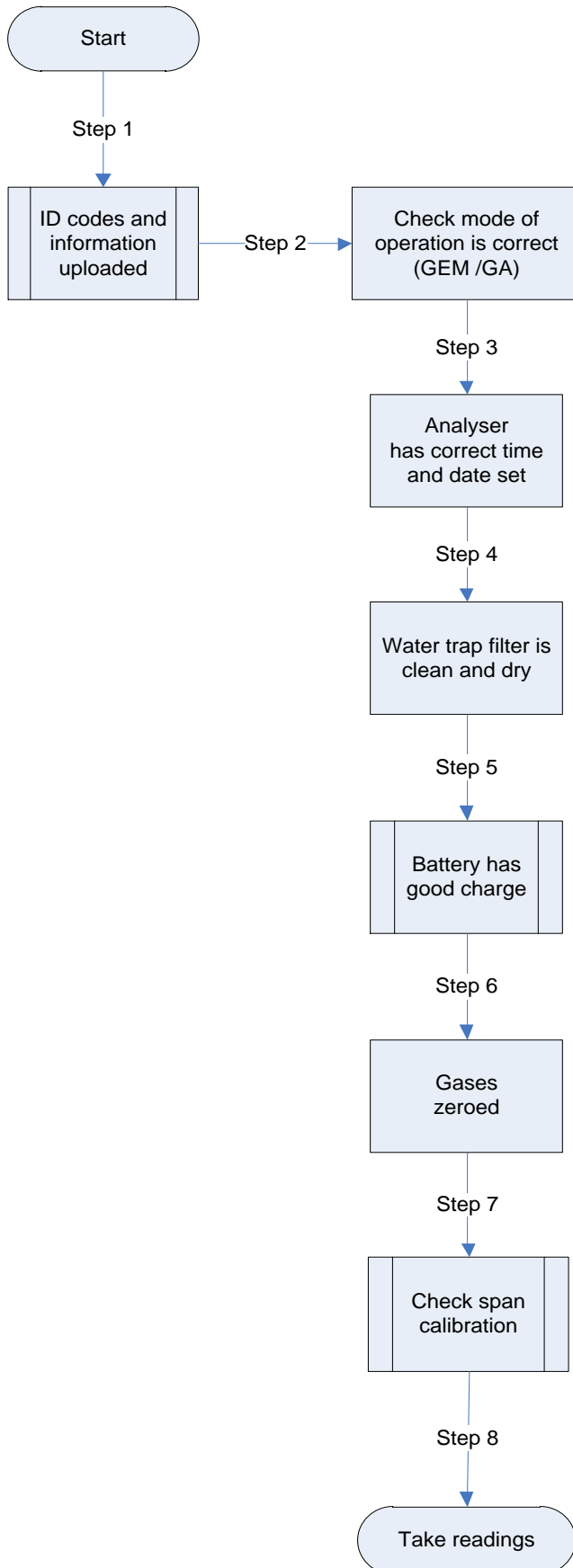

Prior to use, it is good practice to ensure that:

- Step 1** If using LSGAM - all necessary ID codes and information have been uploaded from LSGAM to the analyzer. Please see section 8.1.1 for more information on this.
- Step 2** Check the 'Mode of Operation' is correct. Choose either GEM5000 for gas extraction monitoring analyzer or GA5000 for landfill gas analyzer. Change using 'Special Actions'.
- Step 3** The instrument has the correct time and date set.
- Step 4** The water trap filter is fitted and is clean and dry.
- Step 5** The battery has a good charge (minimum 25% charge, even if only a few readings are required).
- Step 6** The gas channels have been zeroed, without gas concentration present.
- Step 7** If necessary check the span calibration with a known concentration calibration gas.
- Step 8** Take readings.

# GEM5000 Gas Analyzer

---

 <b>Warning</b>	Inhaling hydrogen sulphide gas (H <sub>2</sub> S) or other harmful gases can cause death. It is the responsibility of the user to ensure that he/she is adequately trained in the safety aspects of using H <sub>2</sub> S and other harmful gases. In particular, where hazardous gases are being used the gas exhausted from the analyser must be piped to an area where it is safe to discharge the gas. Hazardous gas can also be expelled from the instrument when purging with clean air.
--	---

## Good practice

- Travel to site with the gas analyzer in the vehicle's interior - not in the trunk or truck bed, where it may be subjected to extremes of temperature and possible shock damage. Do not place the gas analyzer against anything hot (e.g. gas extraction pipe, car body or in an unattended car during the summer) as this will cause a temperature increase in the gas analyzer and may cause erroneous readings.
- When moving around a site, protect the gas analyzer from strong direct sunlight and heavy rain.
- Always use the water trap! If the water trap becomes flooded, change the filter and ensure all tubes are clear of moisture before re-use.

 Note: If the exhaust of a 5000 series gas analyzer is connected to a pressurized system then this results in a flow of gas out of the inlet flow port.

# GEM5000 Gas Analyzer

## 8.2 Change screen layout

Use key 2 to toggle between 2 different ways of viewing the gas reading screen:

Channel	Adjusted	Initial	Previous	Units
CH <sub>4</sub>	81.7	81.7	81.3	%
CO <sub>2</sub>	1.6	1.6	1.7	%
O <sub>2</sub>	16.7	16.7	17.0	%
S5Cell	0	0	---	ppm
Bal	0.0	0.0	0.0	%
Static.P			---	mb
Diff.P			---	mb
Temp.			---	°F
Flow			---	m3/h
Power			---	KW

Default view

Channel	Adjusted	Initial	Previous	Units
CH <sub>4</sub>	80.8	80.8	0.0	%
CO <sub>2</sub>	1.7	1.7	0.1	%
O <sub>2</sub>	17.5	17.5	20.6	%
Bal	0.0	0.0	79.3	%

You can use key 4 and key 6 to switch between the gases page and the pressure & flow page. This feature is only available on analyzers running on firmware version 1.11 or later.

## 8.3 Answering site questions

Prior to taking the readings at a particular site, the site questions should be populated, this is only necessary when using site questions, if not, please proceed with the reading as normal. This is accessed via the 'Special Action' menu. The answers to these questions are then stored and appended to each reading stored thereafter, until the site questions are updated for another site. You will need LSGAM software to create site questions and if you are using LSGAM, this data will be uploaded to LSGAM along with the reading data.

## 8.4 Answering ID questions

Prior to, or after, you have taken the reading, the ID questions should be populated, this is only necessary when using ID questions, if not, please proceed with the reading as normal. When you have uploaded IDs with ID questions assigned to them (LSGAM software required), you will be prompted to answer these questions at the end of the reading, this means that the answer only equates to that reading.

## 8.5 Special action

This menu enables the operator to perform the additional following functions out of sequence if so desired.

- 1) From the 'Main Gas Read Screen' select the soft-key 'Special Action' and the following menu is displayed:

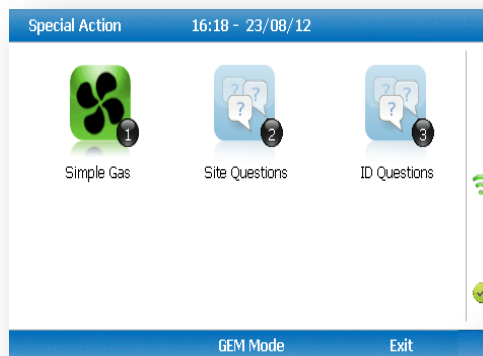

*Note:* The list of special action options displayed on the special action menu is dependent upon device type and sequence.

The following actions may be available:

Action	Function
Key 1 – Simple Gas	This action enables the operator to take a quick gas reading. The pump will start running automatically when this key is selected. The operator can stop the pump by pressing the pump key on the keypad at any time and the reading can then be stored by selecting soft-key 'Store'.
Key 2 – Site Questions	This action enables the operator to update site questions prior to taking a reading.
Key 3 – ID Questions	This action enables the operator to update ID questions specific to sample points prior to taking a reading.
Key 4 – Flow	This action enables the operator to measure internal flow first when taking a reading. Connect the blue hose to the sample point. The yellow hose can be vented a safe distance from the sample point or re-circulated back into the system. Select either soft-key 'Zero Flow', 'Flow Options' or 'Start' to commence internal flow. Select soft-key 'Store' to store and record the reading.
Key 5 – Enter Temperature	This action enables the operator to manually enter a temperature reading if not using a temperature probe prior to taking a gas measurement.
Key 6 – Start Logging	This action enables the operator to leave the analyzer unattended to take samples at a predetermined time. The reading interval and pump run times may be edited prior to commencing the logging cycle.

# GEM5000 Gas Analyzer

## 8.5.1 Configuration of the data logging option



- 1) Connect the gas inlet (white port) to the sample point. The yellow exhaust hose can be vented a safe distance from the sample point; do NOT re-circulate back into the system.
- 2) By selecting 'Next ID' the operator can select the ID which is being sampled at present.
- 3) Once the ID has been chosen the analyzer will commence and complete its clean air purge cycle.
- 4) To gain access to the data logging option the operator will be required to select the 'Special Action' key to obtain the special user options. The data logging option can then be selected via 'Key 6' to configure the logging parameters.
- 5) Once the operator has confirmed the logging parameters, select soft-key 'Start Logging'.
- 6) Once the logging function has been activated the analyzer will carry out a 30 second warm-up (displayed below the temperature read out at the right of the main gas read screen) and begin the first sample.
- 7) If for any reason during the logging cycle the inlet port becomes blocked, the analyzer will sense this as a 'Flow Fail' and the pump will automatically retry until the reading can be obtained. As such care must be taken when positioning the sample tubing to ensure water/moisture ingress does not occur.
- 8) Select soft-key 'Stop Logging' to stop logging if required.

## 8.5.2 Profiling option

- 1) The 'Logging Mode' center soft-key toggles between 'Logging Mode' and 'Profiling Mode' and pressing it will change the mode to the one the soft-key describes. For example, when on the profiling page the key will display as 'Logging Mode' and when on the logging page the key will display as 'Profiling Mode'.



- 2) To edit the parameter the operator will be required to select 'Key 3' to select the number of reading required. Once the number of readings has been updated press the return key to confirm parameter setting.
- 3) By selecting 'Key 2' the operator can edit the logging interval of their logging preferences and then confirm the amendments by pressing the return key.
- 4) Once the logging parameters are confirmed, commence the logging by selecting the 'Start Logging' key.
- 5) If for any reason during the logging cycle the inlet port becomes blocked, the analyzer will sense this as a 'Flow Fail' and the pump will automatically retry until the reading can be obtained. As such care must be taken when positioning the sample tubing to ensure water/moisture ingress does not occur.
- 6) Select soft-key 'Stop Logging' to stop logging if required.

Select the soft-key 'Exit' to exit this menu and return to the 'Main Gas Read Screen'.



# GEM5000 Gas Analyzer

## 8.6 GEM analyzer in GA mode

The operator may toggle between GEM (a gas extraction monitor) and GA (a landfill gas analyzer) mode of operation if required. From the 'Special Action' menu, select the middle soft-key to toggle between GEM and GA Mode.

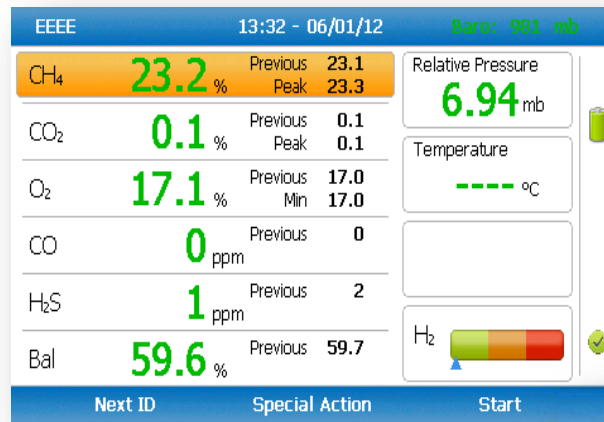

✍ Note: For operating instructions on how to use the GA5000 mode of operation, please refer to the GA5000 gas analyzer operating manual.

## 8.7 The gas flow measurement screen

The GEM5000 gas analyzer enables gas and flow measurements to be recorded by using:

- A flow device i.e. a PITOT tube, Orifice plate, Accu-Flo or anemometer.
- A temperature probe.

The GEM5000 instrument has the extra functionality to measure the calculated calorific value of the gas. The site engineer uses the information recorded by the analyzer to make adjustments to the gas flow for specific boreholes. The initial and adjusted flow rates are recorded.

# GEM5000 Gas Analyzer

---

## 8.8 How to use an anemometer (optional)



The GEM5000 gas analyzer has the facility to attach an anemometer device enabling the site engineer to measure the flow of gas within an extraction system. The anemometer can be set to display two values; m/s (meters per second) and m<sup>3</sup>/hr (metres cubed per hour).

It is best practice to take the gas reading first before taking the flow reading with the anemometer attached.

If using a 'borehole ID' the internal pipe diameter can be predetermined in the optional LSGAM software. Once set, the site engineer cannot edit the pipe diameter setting.

If the site engineer is not using a borehole ID or the pipe diameter is not set in LSGAM the operator will be prompted to enter a pipe diameter with a new ID on the analyzer. Select soft-key 'Next ID' from the Main Gas Read screen, followed by soft-key 'Add' and add a new borehole location.

In order to use the anemometer it is important to know the internal diameter (ID) of the pipe if you want to calculate the flow in m<sup>3</sup>/hr (metres cubed per hour). This must be the internal diameter not the outer diameter (OD) i.e. pipe outer diameter minus twice the pipe wall thickness.

# GEM5000 Gas Analyzer

**For example:**

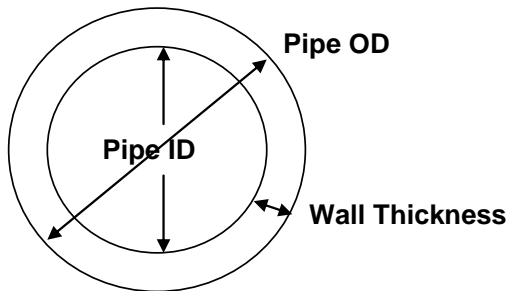

If you do not have any suitable monitoring points you will need to drill (tap of  $\frac{3}{4}$ " BSP pipe thread) a hole in the piping of between 25mm and 30mm in diameter to seat the conical fitting on the anemometer (which is roughly between 20mm to 34mm). When not in use the hole can be re-sealed with a  $\frac{3}{4}$ " BSP male bung.

⚠ Note: When the anemometer is not in use the conical fitting should be placed over the probe to protect it.

The anemometer must fit centrally (the conical fitting must be set on the probe to half the pipe ID before insertion). The arrow on the tip of the probe must point in the direction of the gas flow.

⚠ Note: Use the thumb screw to help align the direction of the probe into the gas stream.

Flow readings are most accurate when there is laminar flow (not turbulent). Turbulence can be caused by a change in pipe direction or restriction. Ideally, upstream you want at least 20 times the pipe ID along the length of the pipe without restriction or bend. Downstream, you want at least five times the pipe ID along the length of the pipe i.e. for a 100mm ID you need 2000mm of clear pipe upstream, 500mm downstream.

**Example to show anemometer fitting into the sample point:**

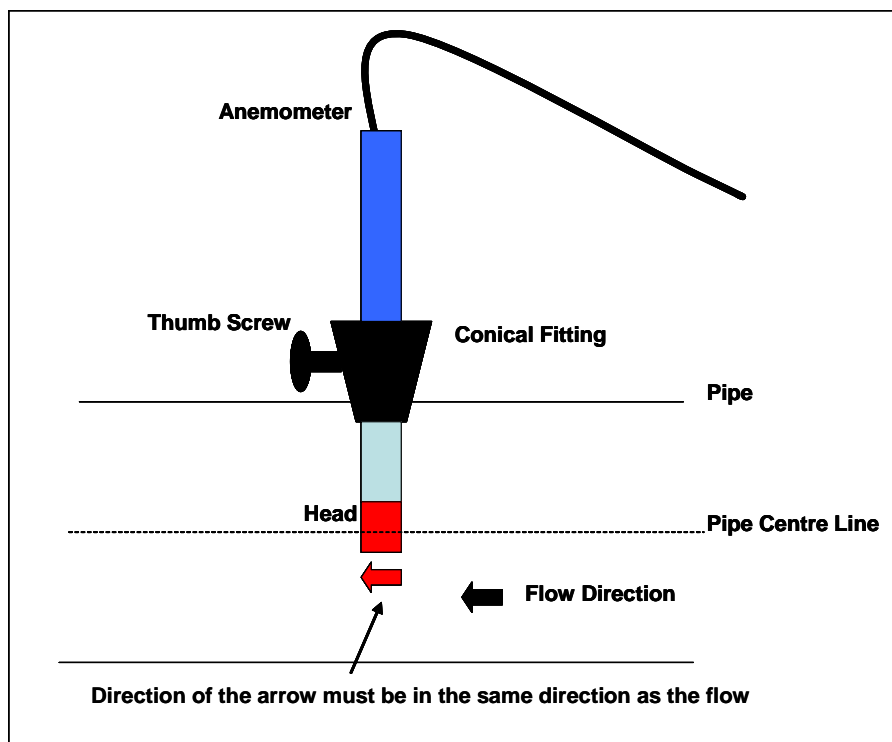

## **Instructions for use:**

- 1) Attach the anemometer to 'Connector C' (refer to section 5.3 – Instrument connection points).
- 2) Place the anemometer into the pipe (sample point) ready to take the reading.
- 3) To take a flow measurement when using an anemometer, follow the instructions displayed on the analyzer. When the reading has stabilized press the 'Enter' key to store the reading.

## **Anemometer cleaning instructions:**

### **General handling tips:**

- Protect the probes against severe vibration.
- Do not kink the connector cable (risk of cable breakage).
- Never allow hard objects to contact rotating impellers.
- Always carry out probe cleaning according to the cleaning instructions.
- Never immerse probes in solvent.
- Never blow probes through with compressed air.
- Allow hot probes to cool slowly, never cool by plunging them in cold water etc.

### **Cleaning instructions:**

- Instrument and probe must be switched off or disconnected prior to cleaning.

### **Vane probes:**

- As the probes are highly sensitive measuring instruments, they must be cleaned with great care.
- Fibres or other foreign bodies can be carefully removed with fine tweezers. When doing so, take care not to bend or otherwise damage the vanes or the spindle.
- The adjustment of the bearing screws must never be changed. This can result in an erroneous measurement.
- Never allow hard objects to contact rotating impellers.
- Cleaning agents that extract the plasticizer from the plastic are never to be used for plastic probes (practically all solvents).

### **Cleaning the probes – best practice:**

✍ Note: Use soapy water.

### **Cleaning example:**

- 1) Carefully, swish the top part of the impeller back and forth in clean soapy water for approximately 10 minutes. Then swish the top part of the impeller back and forth in clean soapy water. If soapy water is used as a cleaning agent it is advisable to wash out the soap solution thoroughly with distilled water.
- 2) After cleaning the probe, rub it dry with a clean, dry cloth.

## 8.9 How to use a pitot tube (optional)

The GEM5000 gas analyzer enables the site engineer to take gas measurements using a pitot tube. The pitot tube is used for gas extraction systems and the pressure readings are taken in mbar. Gas flow is calculated in the analyzer in m<sup>3</sup>/hr (metres cubed per hour).

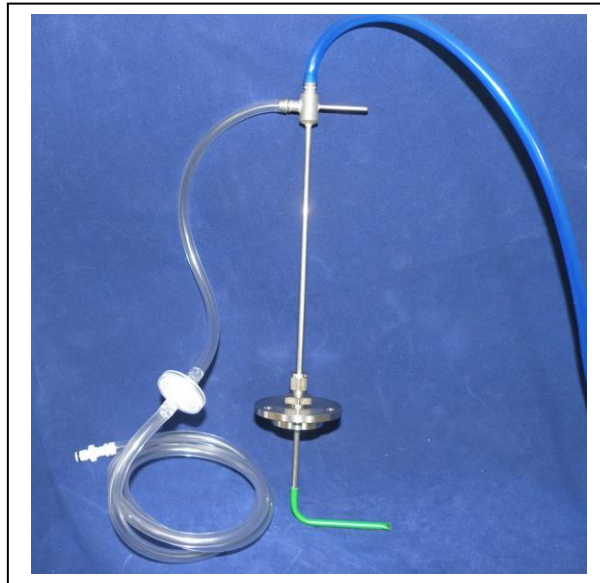

Example of a pitot tube

### **Fitting a pitot tube to the analyzer:**

- 1) It is important to seat the pitot tube into the monitoring point with the tip facing into the gas flow. The pitot tube should also be housed half way down the monitoring pipe. (Please refer to the anemometer instructions, which detail how to calculate the pipe diameter correctly).
- 2) Make sure that the sample tubing attached to the pitot tube fits correctly.
- 3) Attach the sample tube from the top connection of the pitot tube to the 'blue port' (the differential port) on the analyser making sure that the gas port connector secure into place.
- 4) Attach the sample tube from the side of the pitot tube to the 'white port' (inlet port/static pressure port) on the analyser making sure that the gas port connector secures into place.
- 5) House the pitot gland correctly onto the monitoring point.
- 6) When taking a gas reading and flow measurement follow the instruction as displayed on the front of the instrument.

✍ Note: Please refer to the following section for a diagram showing how to fit the tubing to the pitot tube.

# GEM5000 Gas Analyzer

## 8.10 How to use an H<sub>2</sub>S filter (optional)

### 8.10.1 Cross gas effects on chemical cells

Measurements of CO are important in landfill management. The GEM5000 analyzer incorporates an improved CO measurement.

Measurements of CO can be affected by two other gases that can be found in landfill gas – hydrogen and hydrogen sulphide.

To reduce the effect of hydrogen, the GEM5000 analyzer uses a technique that is hydrogen compensated. Hydrogen compensation is achievable up to a level of around 2000ppm. Above this level the CO reading will not be compensated for.

In order to assist the operator the GEM5000 instrument also indicates the level of hydrogen present as low, medium or high. If a high hydrogen reading is present then the CO reading may be affected.

The effect of hydrogen sulphide is eliminated by the use of a H<sub>2</sub>S filter.

#### CO measurement

The CO measurement is sensitive to hydrogen sulphide. The presence of hydrogen sulphide can cause the CO reading to elevate (not to be the true value due to the interfering gas). If the presence of hydrogen sulphide is suspected to be causing false CO readings, then it is recommended that the external hydrogen sulphide filter is used while obtaining the CO measurement.

The H<sub>2</sub>S filter only needs to be used when you are trying to remove of any possible cross gas effects H<sub>2</sub>S might have on other gas channels. Do not use the filter on all boreholes.

When using the H<sub>2</sub>S filter you will need to increase the gas sample and clean air purge run-time, as using an H<sub>2</sub>S filter decreases the response time of the analyzer.

✍ Note: There is an internal H<sub>2</sub>S filter incorporated in the chemical cell that removes the H<sub>2</sub>S; however this has a limited life span.

The electrochemical cells used to measure H<sub>2</sub>S and CO do suffer from cross-gas effects. Such effects are not accurately specified. However, the following table may be useful as a guide; it represents how many ppm would be read by a cell if 100 ppm of the interfering gas were applied, with no other cross-contaminates being present in the sample.

#### GEM5000

		Interfering Gas				
		CO	H <sub>2</sub> S	SO <sub>2</sub>	NO <sub>2</sub>	H <sub>2</sub>
Chemical Cell	CO (H <sub>2</sub> compensated)	100	0 / ~300*	0	0	<1
	CO	100	<4 / ~300*	0	-20 to +5	<60
	H <sub>2</sub> S	<4	100	20	<-25	<0.2

\*after internal filter depleted.

✍ Note: Other gases could cause cross-gas effects. If you suspect a cross sensitivity problem please contact Technical Support (800) 968-2026 or email [landtec\\_support@qedenv.com](mailto:landtec_support@qedenv.com)

# GEM5000 Gas Analyzer

## 8.10.2 Cross-gas effects on methane, carbon dioxide and oxygen

Methane is measured using dual beam infrared absorption. Analyzers are calibrated using certified methane mixtures and will give correct readings provided there are no other hydrocarbon gases present within the sample (e.g. ethane, propane, butane, etc.). If there are other hydrocarbons present, the methane reading will be elevated (never lower) than the actual methane concentration being monitored.

The extent to which the methane reading is affected depends upon the concentration of the methane in the sample and the concentration of the other hydrocarbons. The effect is totally non-linear and difficult to predict.

**Note:** The effect can be reduced by using an H<sub>2</sub>S filter as it can reduce higher order hydrocarbons. When using the H<sub>2</sub>S filter you will need to increase the gas sample and clean air purge run-time, as using an H<sub>2</sub>S filter increases the response time of the analyzer.

Carbon dioxide is measured by infrared absorption at a wavelength specific to carbon dioxide. Therefore, the carbon dioxide reading will not be affected by any other gases usually found on landfill sites.

The oxygen sensor is a galvanic cell type and suffers virtually no influence from CO<sub>2</sub>, CO, H<sub>2</sub>S, NO<sub>2</sub>, SO<sub>2</sub> or H<sub>2</sub>, unlike many other types of oxygen cell.

The infrared sensors will not be 'poisoned' by other hydrocarbons and will revert to normal operation as soon as the gas sample has been 'purged'.

### H<sub>2</sub>S filter:



### Instructions for use:

The following diagram shows how to modify the standard water trap and sample tubing to fit the H<sub>2</sub>S filter.

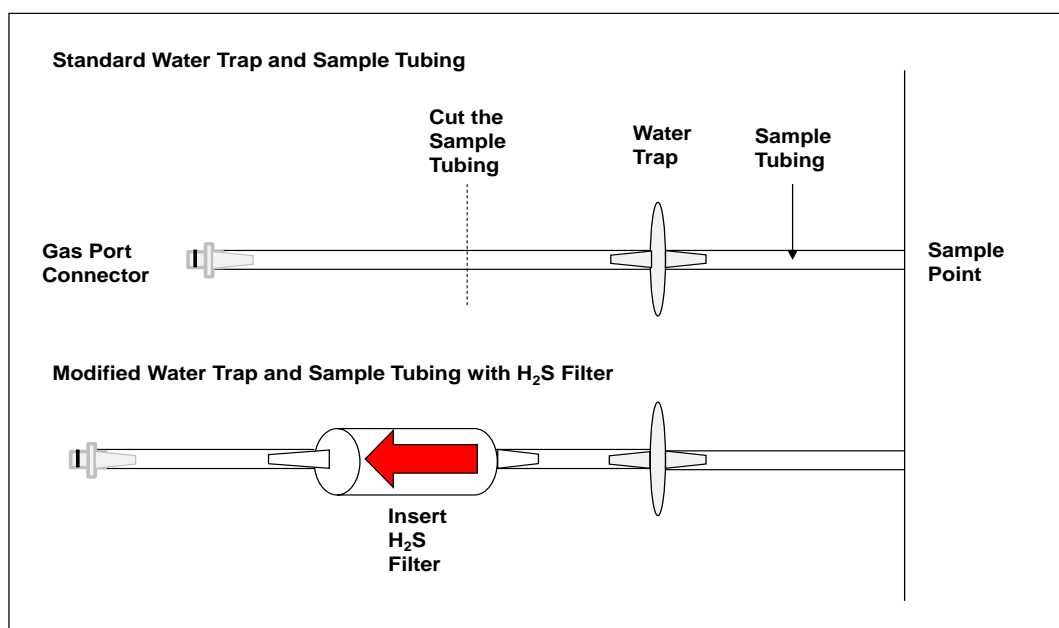

# GEM5000 Gas Analyzer

✍ Note: When onsite the site engineer must have an unmodified water trap assembly in addition to the modified water trap with a H<sub>2</sub>S filter in order to take readings with and without a filter.

- 1) Once the H<sub>2</sub>S filter is fitted follow the instructions as detailed on the front of the gas analyser displayed when taking readings using a H<sub>2</sub>S filter.

✍ Note: This is only for analysers fitted with the CO compensated cell.

## **Fitting a pitot tube to a sample point when using an H<sub>2</sub>S filter:**

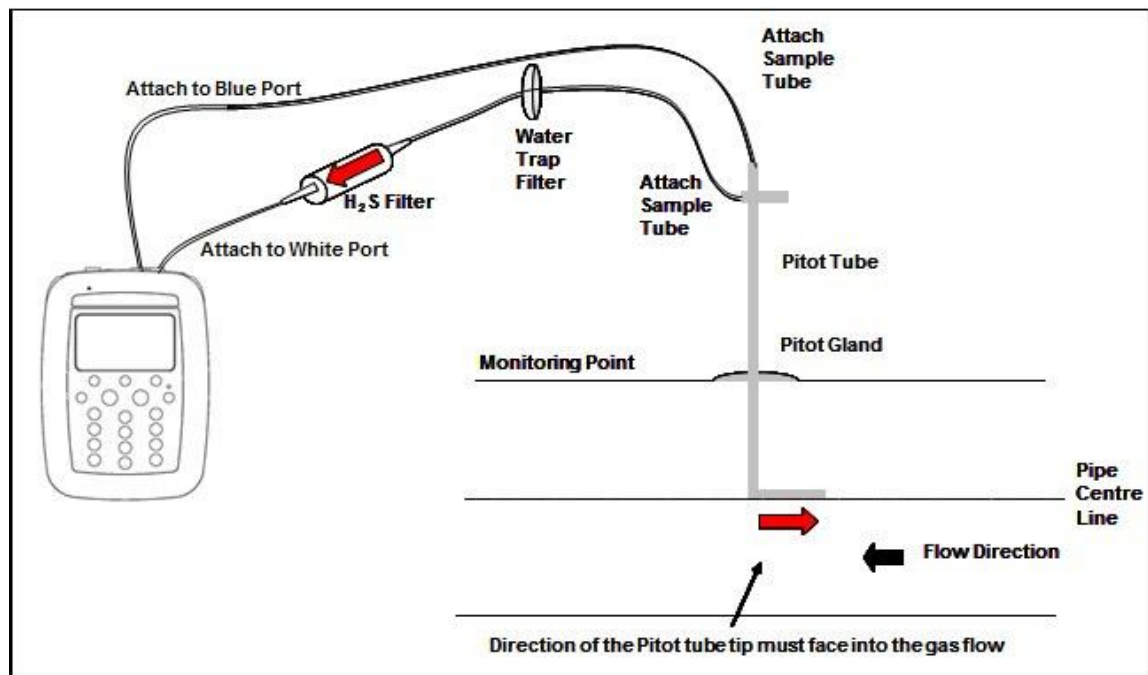

- 2) Make sure the water trap filter is fitted as close as possible to the pitot tube. This will help protect and trap moisture before it reaches the H<sub>2</sub>S filter. Make sure that the water trap filter is clean and dry.
- 3) Attach the sample tubing into the analyzer.
- 4) To take flow readings using a pitot tube, please follow the instructions displayed on the front of the instrument. The user will be prompted to complete each step and should follow the instructions on screen.

✍ Note: It is important to fit the pitot tube central and parallel with the pipe.



## 8.11 How to use a temperature probe (optional)

The temperature probe enables the site engineer to measure the temperature of the gas within a sample point. The GEM5000 gas analyzer uses the temperature of the gas to give more accurate flow measurement readings as part of the instrument calculation.



### **Instructions for use:**

- 1) The temperature probe reading is taken along with the gas measurement reading.
- 2) The analyzer must be at the 'Main Gas Read Screen'.
- 3) Attach the temperature probe to 'connector B' (refer to section 5.3 – Instrument connections points).
- 4) Insert the temperature probe into the sample point (borehole) at the same time as you attach the sample tube to the sample point (two sample points are required for the borehole).
- 5) Follow the instructions on the front of the instrument when taking your gas and measurement reading.
- 6) At the point in which the operator presses 'Enter' to store the gas reading the temperature is recorded.

 Note: Temperature probe readings can be analysed further when downloaded to LSGAM.

## 8.12 How to identify a borehole using the GPS feature (optional)

An optional GPS feature is available for the GEM5000 gas analyzer. It enables the site engineer to automatically locate borehole IDs using GPS satellite signal from predefined borehole IDs uploaded from LSGAM. The GPS reading data is stored for each measurement reading.

**Note:** Borehole IDs may be uploaded from LSGAM with or without location information. If location details are not uploaded the location longitude and latitude coordinates can be stored when the borehole is located and downloaded to LSGAM with the reading measurements.

### Screen navigation:

- 1) Switch on the analyzer and wait for the self-test warm-up to complete and the analyser will display the 'Main Gas Read Screen'.
- 2) In order to use the navigation function if configured, you must switch 'Navigation - On' on the analyzer. Select the 'Menu' key followed by 'Key 5' to toggle navigation to on. Select the 'Menu' key to exit and return to the 'Main Gas Read Screen'.
- 3) Select the soft-key 'Next ID', then select a borehole ID from the list displayed and press the 'Enter' key to continue.

<b>Warning</b>	Before entering the GPS Navigation Screen for the first time the following health and safety message will be displayed.  "Please be aware of the terrain when using this screen. You are responsible for your own safety whilst walking on-site!"
----------------	---

- 4) After reading the user warning message, select the soft-key 'Dismiss'. Use the tracking display to locate the borehole

**Note:** There is often a wait time frame of between 30 seconds to two minutes while getting a satellite signal. Be aware that heavy rain, trees overhead etc. will give a bad fix.

- 5) Once the operator selects a borehole ID the 'GPS Navigation' screen is displayed.



# GEM5000 Gas Analyzer

---

- 6) If required, select soft-key 'Options' to go to the 'Navigation Options' menu and the following screen is displayed:

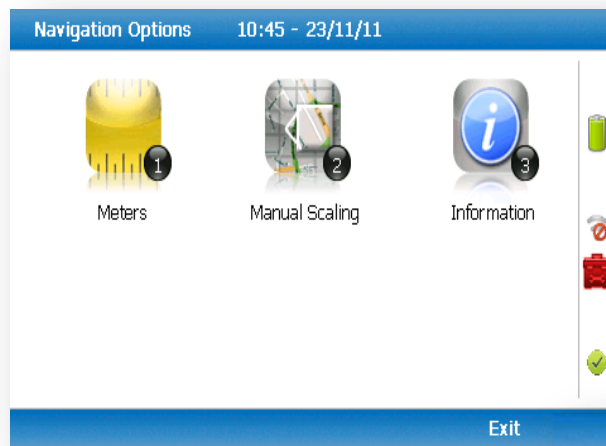

## Navigation options

- |             |   |
|-------------|---|
| Key 1       | Key 1 to toggle between 'Meters', 'Feet' or 'Yards' to define the unit of measurement.  |
| Key 2       | Key 2 to toggle between 'Manual Scaling' and 'Automatic Scaling' to locate a sample point using a satellite signal.   |
| Key 3       | Key 3 to display sample point information:  |
| Bearing:    | Direction.  |
| UTC time:   | 'Universal Time Code' received from the satellite and displays GMT.   |
| Latitude:   | Latitude displays as degrees, minutes, seconds and decimal seconds. The equator is 0.   |
| Longitude:  | E (East) or W (West) displays the longitude as degrees, minutes, seconds and decimal seconds. The Greenwich meridian defines the zero point.                          |
| Altitude:   | Altitude displays in meters, feet or yards.   |
| Satellite:  | This is the number of satellites that the system can select. Four satellites will give reasonable position accuracy; eight or more satellites will increase accuracy. |
| Horizontal: | Estimate of horizontal error on the indicated position. The location is accurate to horizontal error 1.6m.  |
| Vertical:   | Estimate of vertical error on the indicated position.   |
| HDOP:       | 'Horizontal Dilution of Precision' which measures the accuracy of the indicated position.   |

# GEM5000 Gas Analyzer

---

## Changing the selected ID

It is possible to change the currently selected ID (identified by green icon ) by pressing the 2 and 8 and keys to move the cursor up and down the list of visible IDs. To change the selection press Enter. Notice that the selected ID moves to the top of the list and its icon turns green.

## Changing the scale

You can change the display's scale by using the 4 and 6 keys to zoom in and out.

### GPS signal strength:



This icon shows the signal strength the analyzer's GPS module is able to provide. Full, okay and fair strength respectively.



GPS failure - the GPS was unable to get a line of sight lock on enough satellites. Or, it may be that it hasn't had time to get a lock.

- 7) Select soft-key 'Continue' and the operator is returned to the 'Main Gas Read Screen'.

## 8.13 Taking gas and flow measurement

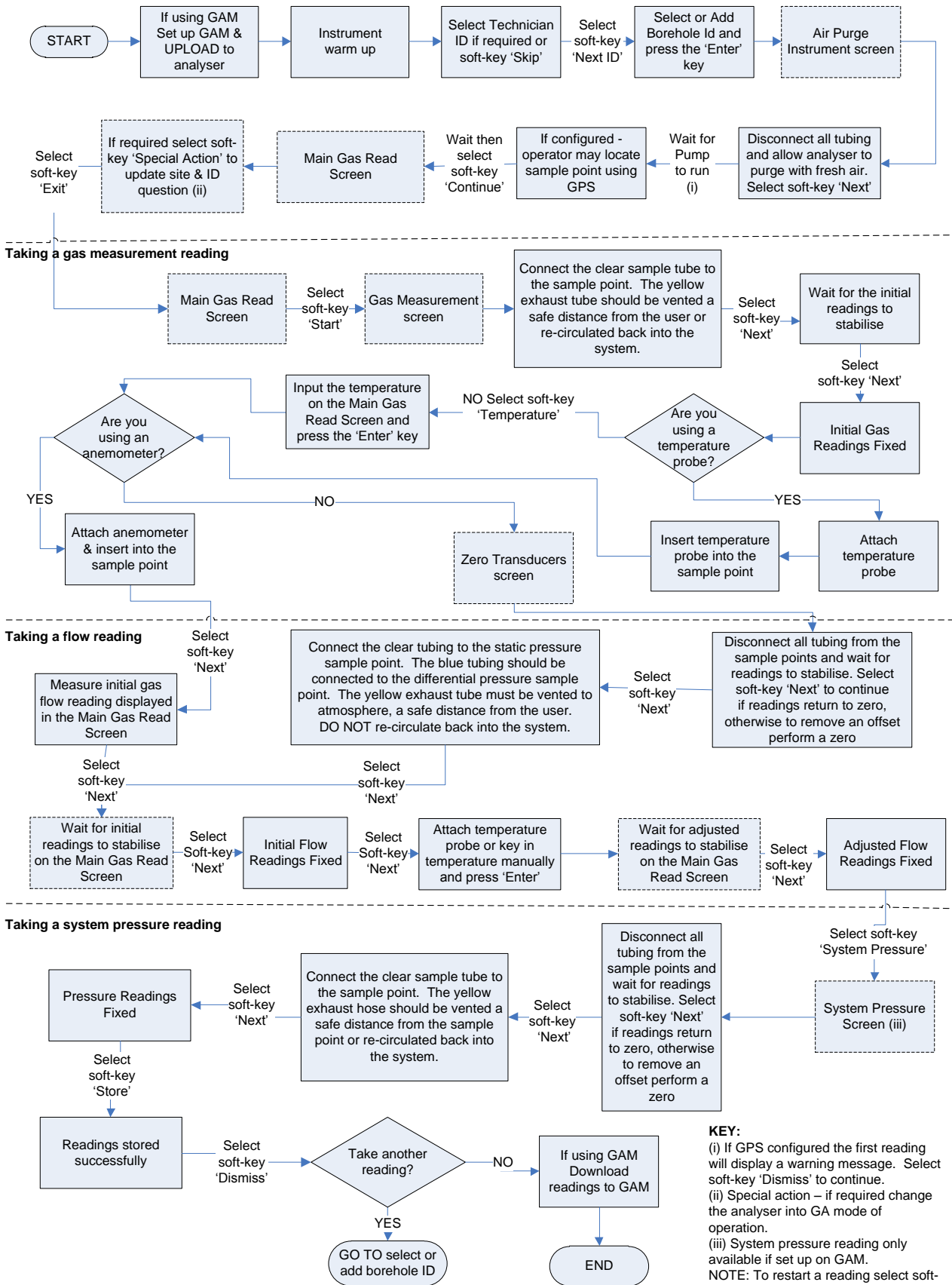

**KEY:**  
 (i) If GPS configured the first reading will display a warning message. Select soft-key 'Dismiss' to continue.  
 (ii) Special action – if required change the analyser into GA mode of operation.  
 (iii) System pressure reading only available if set up on GAM.  
 NOTE: To restart a reading select soft-key 'Special Action' followed by key 1 'Restart Process'.

## 9.0 Calibration

### 9.1 Calibration Introduction

The GEM5000 gas analyzer is carefully calibrated at manufacture and when returned for service. However, it is sometimes desirable to be able to carry out a calibration process between services.

This section outlines the correct procedures to enable the site engineer to field calibrate the gas analyzer.

✂ Note: This does not replace the factory service and calibration. If this calibration is completed incorrectly it may decrease the accuracy of the gas analyzer.

CH<sub>4</sub>, CO<sub>2</sub> and O<sub>2</sub> can be measured by GEM5000 gas analyzer as standard; these channels can be user calibrated. The analyzers have other gas channel options that are specified at manufacture; these too can be calibrated. This section will describe in detail how to calibrate the three standard gas channels plus the CO channel.

The GEM5000 instrument can have a H<sub>2</sub> compensated CO channel. This option requires that H<sub>2</sub> is used in the calibration process and is also set out within this section.

For the other gas channel options contact QED for advice.

Two important terms that are used within this section are 'Zero' and 'Span'.

**Zero:** The point at which the gas analyzer is calibrated when there is none of the target gases present.

**Span:** The point at which the gas analyzer is calibrated when a known quantity of the target gas is present.

### 9.2 Frequency of calibration – best practice

The GEM5000 gas analyzers can be checked against a known concentration of gas, to give confidence that the analyzer is operating as expected at the time and conditions in which it is being used.

It is recommended that the instrument is regularly serviced and calibrated by QED in accordance with the due date on the instrument.

When defining the frequency of user calibration, the following are factors to be considered:

- The frequency of use of the analyzer. (daily?/monthly?)
- The level of confidence and accuracy required for readings to be taken.
- Historical user calibration data.
- Site specific requirements or conditions.
- Historical understanding of expected readings on site.

Zeroing of the gas analyzer should be undertaken at the start of each day's monitoring.

Use historical data to drive your frequency of calibration.

If there is no historical data a good starting point for a daily monitoring round is performing a calibration once every week or every other week.

The results of the calibrations will need to be recorded to monitor over time whether the frequency of calibration needs to be increased or decreased relative to the confidence required.

# GEM5000 Gas Analyzer

---

The confidence required will be driven by the site specific / user requirements.

When undertaking the monitoring with an understanding of the history of the gas levels of that site, a calibration check could be triggered if the readings measured are different to what is expected.

✍ Note: For assistance please contact Technical Support at (800) 968-2026 or email [landtec\\_support@qedenv.com](mailto:landtec_support@qedenv.com)

## 9.3 Calibration gases

User calibration of a gas analyzer will greatly improve the data accuracy in the range of the calibration gases used. This may cause less accurate readings of concentrations outside this calibrated range. Users should select the correct calibration gas for the expected gas levels on their particular application.

- To improve calibration at lower levels requires the use of gas mixtures 1 and 2.
- To improve higher levels use gas mixture 3.
- For standard CO only 100ppm CO gas is needed.
- For CO (H<sub>2</sub> compensated) both CO 100ppm and H<sub>2</sub> 1000ppm gases are needed.

The following table indicates the different gas mixture canisters used for calibration:

Calibration gas	CH <sub>4</sub>	CO <sub>2</sub>	O <sub>2</sub>
Mixture 1	5%	5%	6%
Mixture 2	5%	10%	0%
Mixture 3	60%	40%	0%

Calibration targets for gas cells are dependent on the gas/range and type of cell fitted. Contact Technical Support for assistance.

These are for general use but other gas concentrations can be used.

✍ Note: The above gases and most other gas concentrations can be supplied by QED. For further information please contact Sales at (800) 624-2026 or email [info@qedenv.com](mailto:info@qedenv.com)

 <b>Warning</b>	Calibration gases can be dangerous. For each gas used the appropriate material safety data sheet must be read and understood before proceeding.
--	--

## 9.4 Calibration set-up

 <b>Warning</b>	Do NOT attach the gas supply to the gas analyzer before putting the analyzer into the 'Gas Check' screen. Select 'Check Spans' from the 'Operation Settings' menu.
--	--

The regulator supplied with the calibration kit has been configured to deliver a fixed flow.

# GEM5000 Gas Analyzer

As the regulator's flow is factory set, it only requires a few turns to open, no adjustment is necessary.

<p><b>⚠ Warning</b></p>	<p><b>Exhaust port</b></p> <p>When the gas analyzer is being calibrated, there are two possible exits for the gas, via the usual manner out of the exhaust (yellow) port of the analyzer or in cases of over-pressurisation the 1/16" port on the red pressure relief valve located on the regulator.</p> <p>It is recommended that both ports have exhaust tubing attached.</p> <p>The exhaust tubing must emerge in a well-ventilated area. Ensure there are no leaks in the tubing and connections.</p> <p>The calibration of the gas analyzer should be carried out in a safe area with all necessary precautions taken when using potentially dangerous, explosive or toxic gases.</p>
-------------------------	---

⚠ Note: There is also potential for gas to expel from the internal flow (blue) port of the gas analyzer (applies to the GA5000 only).

## 9.5 Calibration equipment

The diagram below displays the regulator and tubing equipment for user calibration:



- Certified calibration gas, available in either 29 liter, 34 liter or 58 liter gas canisters are supplied with the Landtec calibration kit. Please refer to the Landtec website [www.landtecnica.com](http://www.landtecnica.com) for further information.
- The regulator supplied with the calibration kit is pre-set for flow and pressure rates that are factory set.
- If you are using a non Landtec supplied regulator, please ensure that it does not supply any greater than 200 mbar pressure.



# GEM5000 Gas Analyzer

## 9.6 Gas analyzer

For the GEM5000 gas analyzer the calibration options can be found by selecting the 'Menu' key followed by soft-key 'Operation Settings'. Select 'Key 2 – Gas Check' then follow the instructions on the analyzer screen by selecting 'Key 2 – Gas Check'.

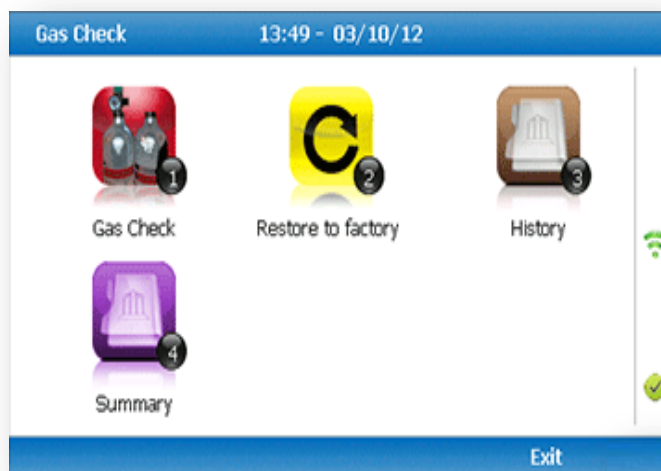

## 9.7 Calibration processes – best practice

The following process diagrams outline the calibration steps.

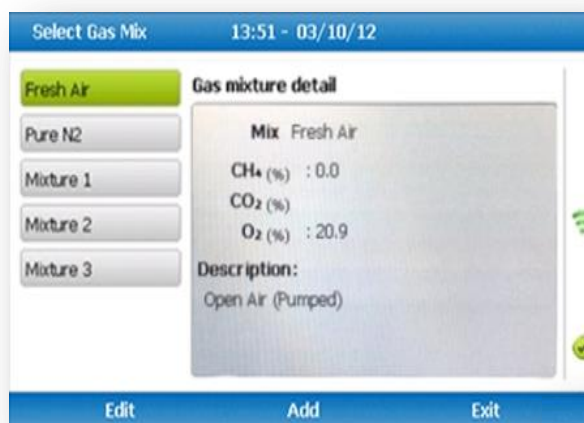

- Ensure that you are regulating calibration gas down to below 200 mbar pressure, if you're not using a Landtec regulator. The use of a pressure relief valve is also highly recommended.
- When calibrating, it is recommended to use a calibration mixture close to the levels you are trying to measure, i.e. if you are trying to measure gas migration on a closed landfill, we'd recommend calibrating with CH<sub>4</sub> 5%/CO<sub>2</sub> 5%.
- In regards to frequency, we would recommend that you perform a fresh air calibration before each monitoring session, and a span calibration typical every 4 – 6 weeks.

# GEM5000 Gas Analyzer

## 9.7.1 Gas Check in fresh air

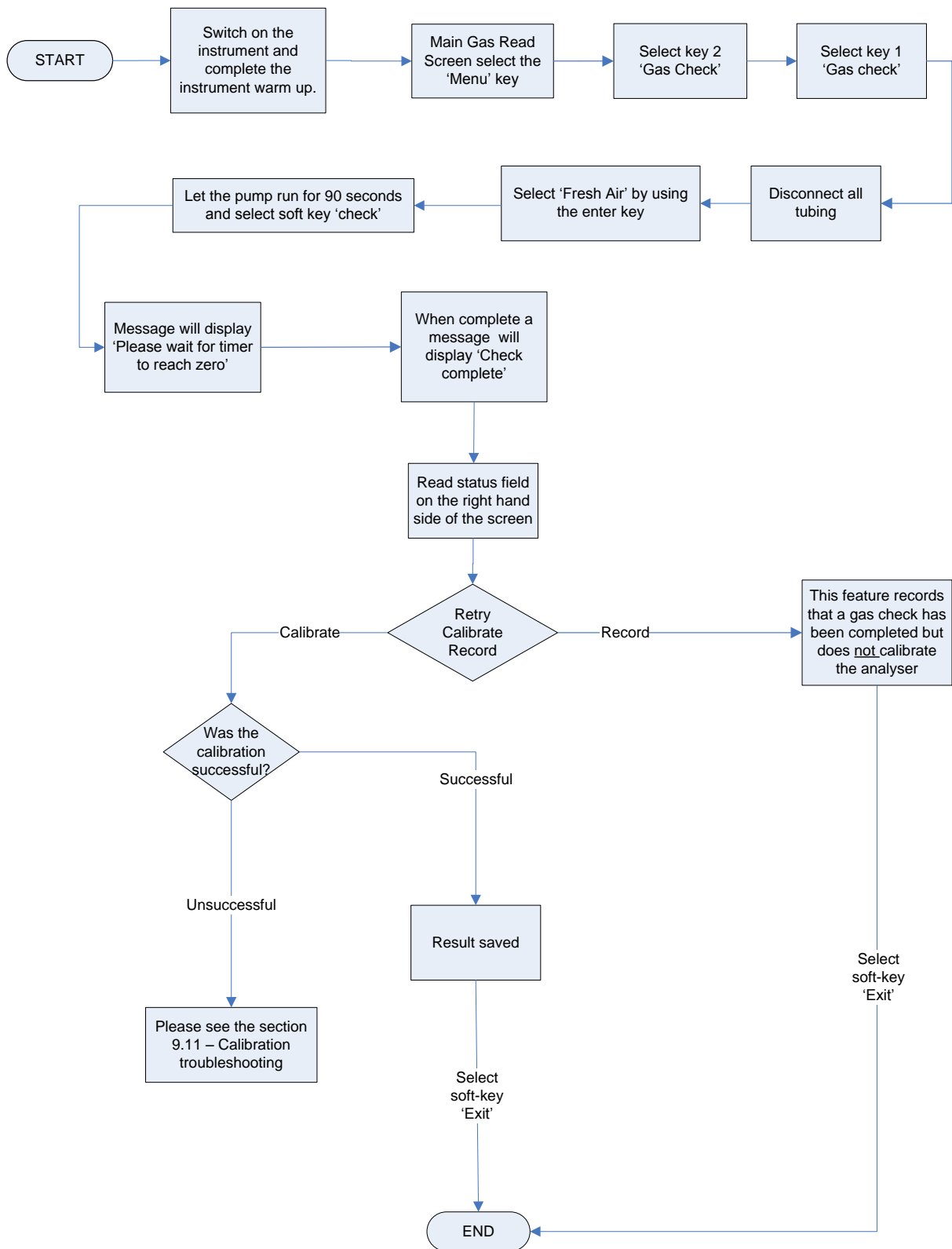

# GEM5000 Gas Analyzer

## 9.7.2 Calibration – mixtures 1, 2, & 3

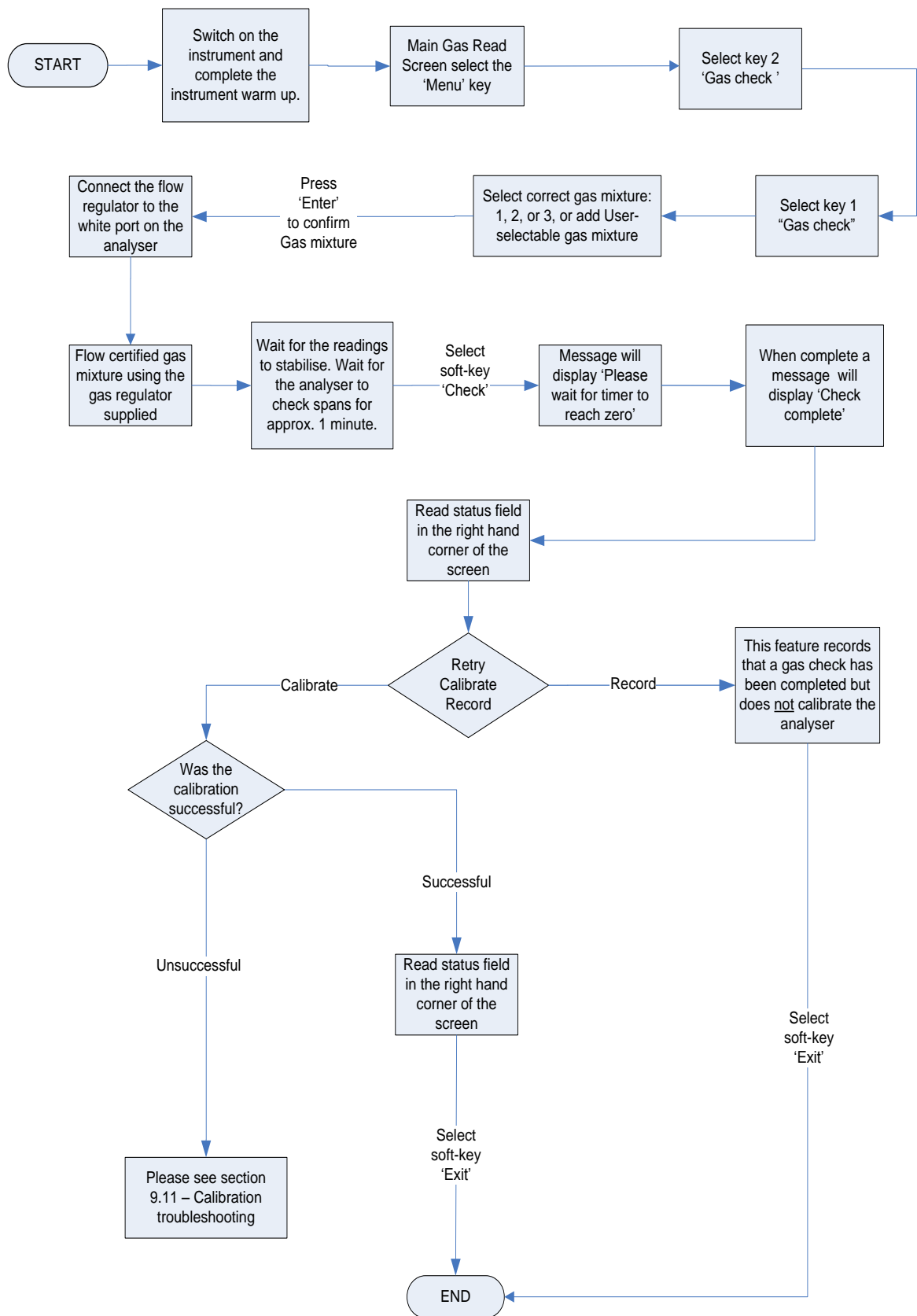

## 9.8 Restore to factory settings



This option will reset the gas analyzer to all of its factory programmed calibration settings and will clear ALL the user defined calibration points. It will not affect or remove ID's or readings from the analyzer.

- 1) Select 'Key 2 - Restore to factory' followed by the soft-key 'Confirm' or 'Cancel'.
- 2) A validation message is displayed 'Reset user calibration?' Press the soft-key 'Confirm' to continue with the factory settings or soft-key 'Cancel' to cancel the operation and return to the Gas Check menu.

## 9.9 Calibration history

The GEM5000 gas analyzer logs user calibrations in 'History' application. This can be used as an aid to ensuring that gas measurements are valid and accurate. Both good and failed calibration results are recorded for each channel calibrated.

- 1) Select 'Key 3 - History'.
- 2) The operator may view the calibration data stored. Use the soft-key 'Filter' to add a sort filter to the history enquiry.

## 9.10 Calibration summary

The GEM5000 gas analyzer has the facility to log the history of user calibrations.

- 1) Select 'Key 4 - Summary'.
- 2) The operator may view the calibration data history stored by ID, technician, timestamp, type and calibration result. Use the soft-key 'Exit' to exit and return to the 'Gas Check' menu.

# GEM5000 Gas Analyzer

---

## 10.0 The LANDTEC System Gas Analyzer Manager (LSGAM) Software

LSGAM software is used to communicate with the GEM5000 and GEM2xxx family of instruments. This allows a simple upgrade of information from older GEM2xxx instruments to the GEM5000 instruments.

### Configuration Options

The GEM5000 instruments and LANDTEC System Gas Analyzer Manager (LSGAM) software can be utilized in a number of ways:

- Configured for operation with the LANDTEC System online service
- Used offline as a local application storing information on the desktop/laptop computer
- Use of the GEM5000 out of the box without software; (this does not allow the user to generate flow rate values, select comments or select IDs with the instrument. This also prevents downloading of readings to the computer.)

*Note: Certain functions that are new to the GEM5000 and are controlled by LSGAM may not be compatible with the GEM2xxx instruments. In such cases, the most compatible configuration will be used. For example: the GEM5000 supports switching of modes based upon ID setup but the GEM2xxx does not. As such, ID's with "NO Flow (GA Mode)" are sent to the instrument as "User Input". Likewise, the ACCU-FLO 1.0V wellhead was introduced after the GEM2xxx was released and the GEM2xxx does not have support for this particular flow device but the GEM5000 does. ID's containing an ACCU-FLO 1.0V flow device will be sent to the GEM2xxx instrument as "User Input".*

*If using a mix of GEM2xxx and GEM5000 instruments, it is recommended to do all LSGAM related setup work with the GEM5000 instrument in order to take advantage of the new features.*

### 10.1 LANDTEC System Online Users

The procedures included in this section are intended for those who connect to the LANDTEC System online service. The LANDTEC System is an online collaboration tool to Collect, Validate, Analyze, and Communicate information based on field data obtained using LANDTEC instrumentation. LANDTEC offers a variety of On-Line service subscription levels for LANDTEC System software.

If you are a currently registered user on the LANDTEC System, please log in at <http://www.landtecsystem.com/>. If you are not currently using the LANDTEC System, you may register by contacting LANDTEC in the US: (800) 968-2026.

Online reference for using LANDTEC System Gas Analyzer Manager (LSGAM) with the LANDTEC System can be found under the About → Help & Support menu within the LANDTEC System.



If you do not have login information please contact LANDTEC System Technical Support at (800)968-2026. Alternatively, you may contact your local LANDTEC office for information on connecting to the LANDTEC System online service.

### 10.2 Offline Users

The procedures included in the section describe use of the LANDTEC System Gas Analyzer Manager (LSGAM) Software while **NOT** connected to the LANDTEC System online service.

# GEM5000 Gas Analyzer

## 10.3 Installation with CD or Memory Stick

### System Requirements

- Windows XP, Vista, 7, 8
- Pentium 750MHz or faster
- 128MB RAM
- 200MB Hard Drive Space Available
- CD-ROM Drive
- Available USB port or bluetooth connection

*NOTE: The computer may need administrative privileges to install the program. Program may run on other versions of Windows but LANDTEC has not tested the program on older versions of windows or with lesser processor and memory requirements.*

As part of LANDTEC’s continual improvement process, LANDTEC has consolidated its product information and instrument communications software into one menu structure. On your memory stick or CD you will find technical information, instrument communication software, USB cable drivers, videos and instrument manuals.

To install the USB Cable Drivers and LSGAM (instrument communication software) from this media format, you will need to place your CD or memory stick into your computer. If you have a CD it should automatically start. If you have a memory stick, you may have to browse to it in your computer and then click on the **ClickHereToStart.htm** icon. If you don’t have a CD or memory stick, simply call LANDTEC’s technical support for internet links required to install the software.

Once the media opens, you should see the GEM5000 and GEM2000 instruments on the homepage.



Click on the GEM5000 instrument to open the LSGAM Software Setup.



From the setup screen you will see four buttons directly related to the GEM5000:

- Step1 Communications Driver
- Step2 Install LSGAM Software
- 5000 Manual
- Instructional Videos

*Note: Technically the communications drivers differ between the GEM2000 and GEM5000*

# GEM5000 Gas Analyzer

---

*instruments, however, the driver package included with the 5000 instruments shipping after Nov 1, 2012 include drivers for both the GEM5000 and GEM-2000 instruments. The LSGAM software for the GEM5000 is backwards compatible for the GEM2000 instruments.*

The LSGAM software will automatically update if an internet connection is available when the software starts. This software has been tested with Windows XP and Windows 7.

Should you have any difficulties, please don't hesitate to contact us. Our Software support group can be reached at (800) 968-2026 or [landtec\\_support@gedenv.com](mailto:landtec_support@gedenv.com). The instrument communicates to the computer by means of a USB cable or by bluetooth. The USB cable requires drivers to be installed prior to use on the computer. From the CD (or USB memory stick) choose the first option titled "Step 1". A Bluetooth connection requires the instrument to be paired to the computer. Refer to the section "[Configuring Communications](#)" for more details.

The Java programming is an import part of this software and will be loaded with the installation. If you have internet access, it is recommended to update your java to the latest version by going to <http://www.java.com/en> then clicking the button for the Free Java download. Once at the Java downloads you'll see links to download the latest version of Java for your computer.

The Java icon, shown below, will be in the task tray at the bottom of your computer screen where your time is shown. There will also be a GAM log icon, shown below, that will be created on your desk top during installation.



## 10.4 Start Up

Once the USB cable drivers are installed and you've checked for the latest Java Runtime from the [www.java.com/en](http://www.java.com/en) website, click on "Step 2 — Install LSGAM". LSGAM will install placing an Icon on your desktop and a new Start Menu Group named LANDTEC.

Starting LSGAM can be easily done by doing one of the following:



Double-Click on the Desktop icon.

OR - go to;

Start → All Programs → LANDTEC → LANDTEC System Gas Analyzer Manager

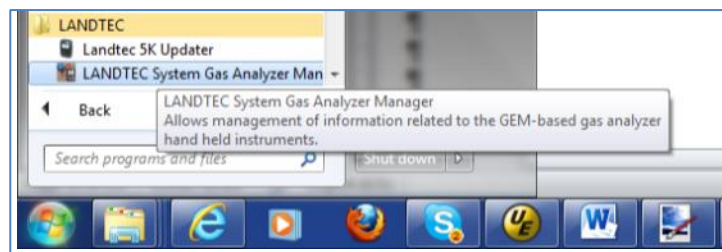

The software will start.

# GEM5000 Gas Analyzer

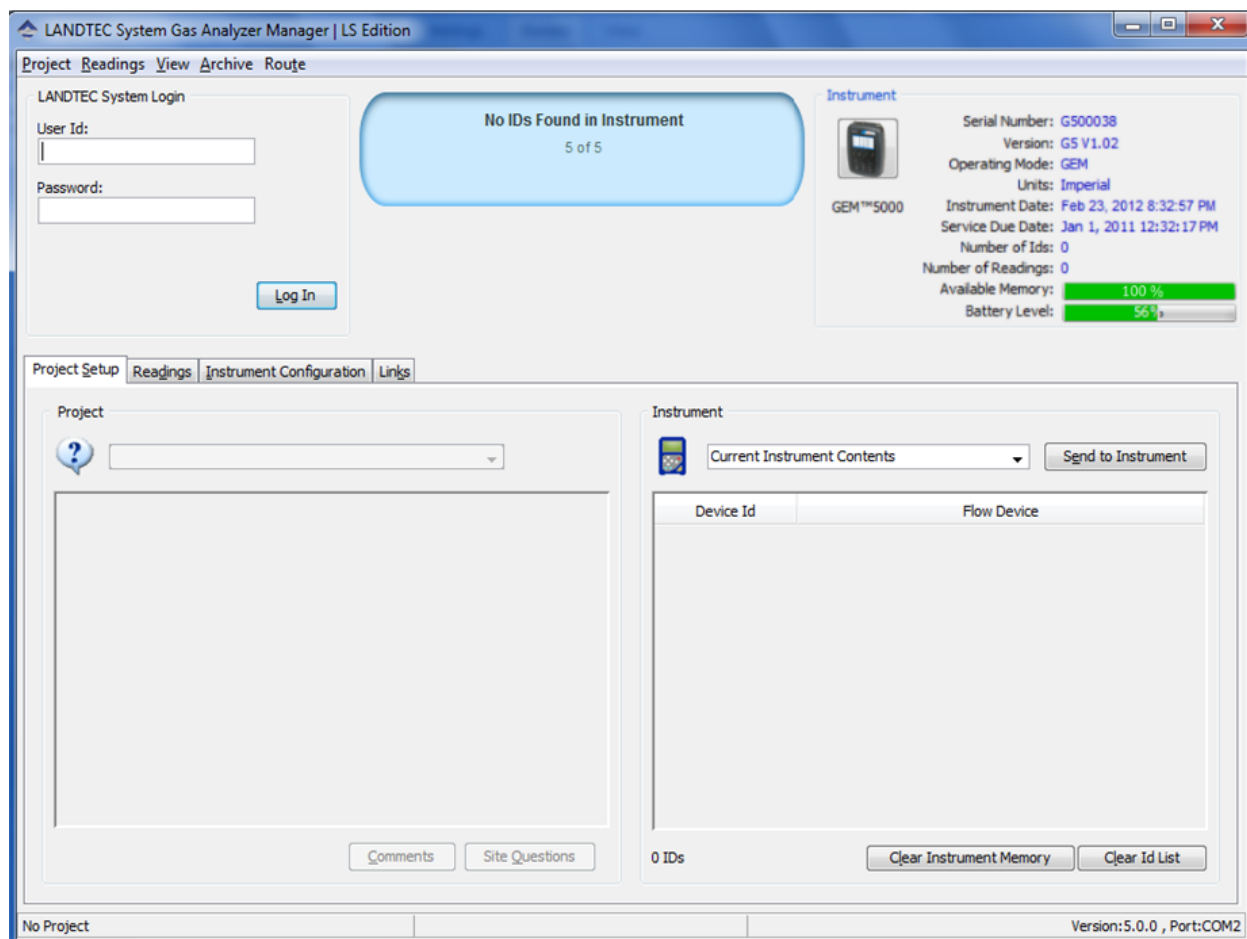

## 10.5 Navigation

The LANDTEC System Gas Analyzer Manager User Interface allows for easy access and navigation to various utilities to use the LANDTEC portable instrument on a day to day basis. The following is a general description of the user interface.

### LANDTEC System Login

When LSGAM is used with the LANDTEC System online service, the username and password will be entered in the screen below, if you are using LSGAM as a desktop application the User Id and Password fields do not need to be filled in.

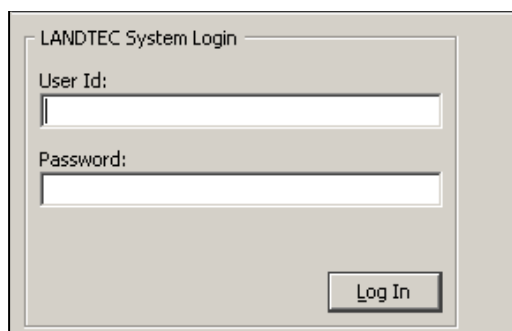

The Progress section indicates the status of the current process. For example, when starting up LSGAM, this will show you the activity of the software.

The Instrument section displays whether or not an instrument is connected. This also downloads the IDs, readings, and comments. If an instrument is found the following details are shown about the instrument:



# GEM5000 Gas Analyzer

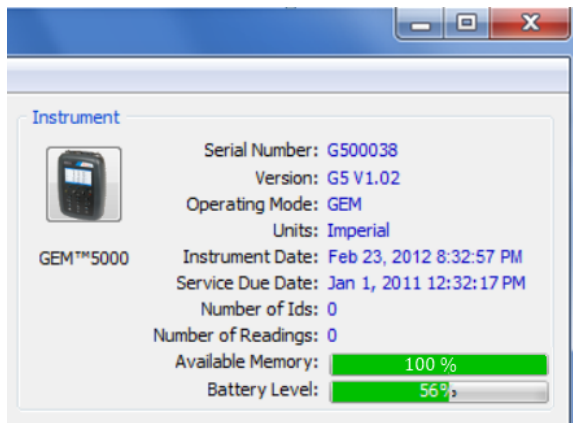

## 10.6 Connecting to the Instrument

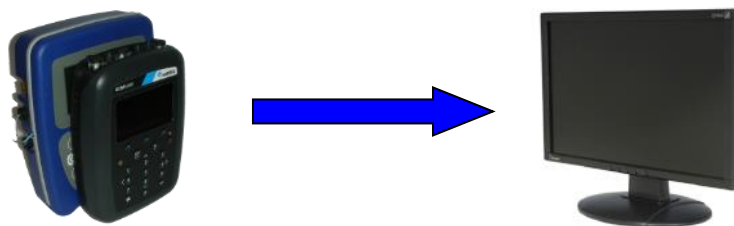

- Connect the GEM5000 to your computer with either the USB cable or a Bluetooth connection. In the event your instrument has difficulty connecting, refer to [Appendix—Configuring Communication Connections](#) for more information setting up and testing USB Serial communications and Bluetooth Serial communications.
- The Instrument must be powered ON and in the Gas Reading screen
- Launch the LSGAM software by clicking on the icon on your desktop



This is the first screen you will see when starting the program.



Once the software is installed on your computer with an internet connection this instrument communications program has Auto application updates. This enables you to always have the most current version of the instrument communications LSGAM.

If an update to LSGAM is available, you will be prompted to install the update.

# GEM5000 Gas Analyzer

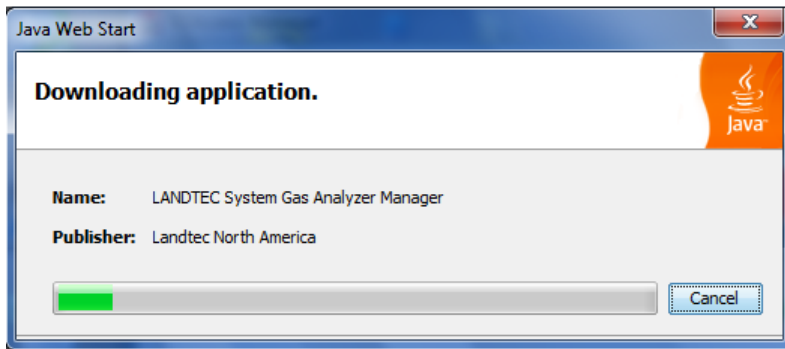

Click on OK this will return you to the desktop and you will then need to click on the LSGAM shortcut again.

The GEM5000 must be connected to computer and turned ON. It must also be in the Gas Reading screen. The LSGAM software will automatically download any information in the instrument including readings, comments and IDs.

**Note: Connection of instrument to computer should not be performed in a hazardous area.**

A new instrument containing no information will display only the instrument information: Serial Number, Version, Operating Mode, Instrument Date, Service Due Date, Number of IDs, Number of Readings, Available Memory, and Battery Level.

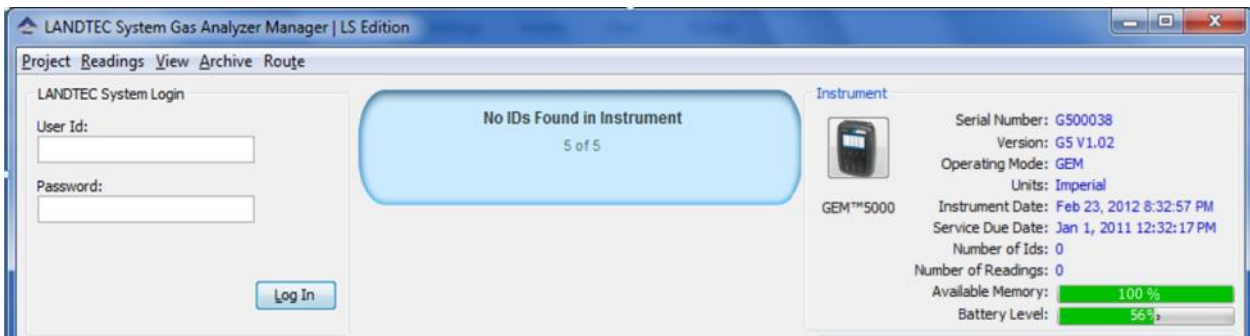

## 10.7 Create a Project/Select a Project

Projects are a collection of Device IDs and their associated reading history. A project can be created using LSGAM to contain a group of sequenced IDs and chronological history of instrument readings.

To create a Project, click on the Project menu and select New Project.

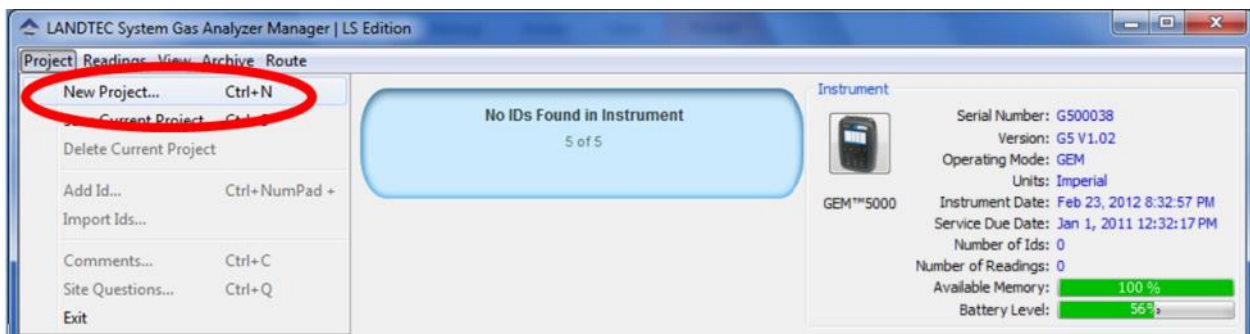

# GEM5000 Gas Analyzer

---

Upon selecting **New Project...** you will be prompted to enter a Project Name and select from one of three options.

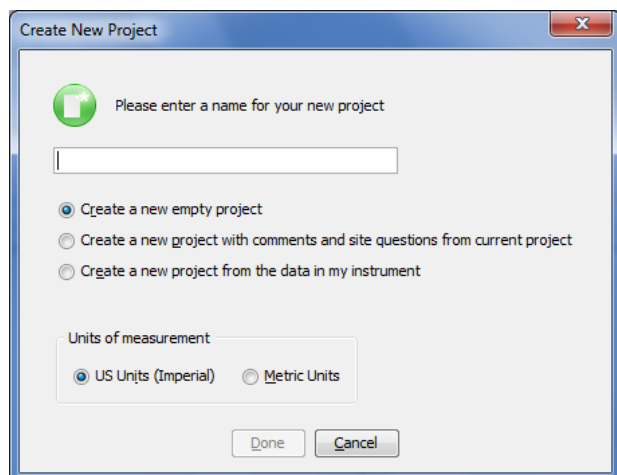

## **Create a New Empty Project**

This option creates a blank project where you configure all IDs and Comments. Alternately ID's can be loaded from a file using the DataField CS version 3.4 ID file format.

## **Create a New Project with comments and site questions from a Current Project**

Selecting this option allows the user to create a new project that will have the same Comments and Site Questions as an existing project.

## **Create a New Project from the data in a GEM instrument**

This option will create a New Project and automatically associate the IDs, Comments, and Site Questions that exist in the connected portable instrument.

### **10.7.1 ID Set Up**

An ID represents a physical sampling point in the field. An ID can be allocated to field components such as extraction wellheads, gas transmission lines, or passive monitoring probes. LSGAM allows users to configure an ID for each sampling point in order to obtain accurate readings with LANDTEC portable instrumentation

IDs are created, modified, and removed from the Project Setup tab in the software.

### **10.7.2 Creating Comments**

Comments should be setup prior to creating new IDs. The user can define Comments that can be associated with a reading in the portable instrument.

If you selected Create a New Project, when creating your project, you will need to click on the Create Comments button. Comments can be entered in this setup screen or loaded from a text file and will be displayed in the user interface. Comments can be 64 characters in length. "Notepad" or another text editor can be used to create a file containing one comment per line up to 64 comments in total.

*Note: It is extremely important to NOT include any punctuation other than dashes or underscores when setting up a comments file in notepad. Commas and Quotation marks are used by programs for determining where data begins and ends. Using characters other than underscores and dashes and cause unpredictable results within the data when downloaded*

# GEM5000 Gas Analyzer

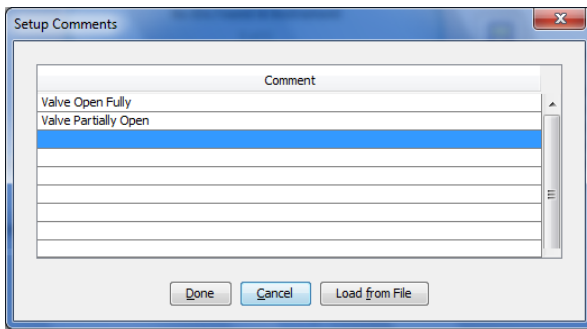

## Typical Comments Might Include

Valve Fully Open
Valve Partially Open
Valve Closed
Air Leak in Wellhead
Water Blockage in Header
Surging at well
Sample Port Needs Replacement
More Vacuum Needed
5 Day Recheck

## 10.7.3 Creating ID's

There are several ways to input IDs to the Project. The following describes each process:

Creating new IDs with LSGAM

To create a new ID using the LANDTEC System Gas Analyzer Manager, Right Click on the left ID pane beneath your active project and select the Add New ID option.

The Add New ID form will be displayed. From the ID Information tab of this form, entry of the following is available:

*Note: LAT & LONG will only be available on GEMs with the NAV option*

# GEM5000 Gas Analyzer

## **ID INFORMATION**

**Device ID:** Must be eight (8) alphanumeric character spaces. (For example, ALFGW001)

## **Device Type:**

- Well: An active gas extraction well connected to a piping network which may require a flow rate reading.
- Sample Port: A sample point along a gas transmission line that may require a flow rate.
- Probe: A passive gas migration monitoring probe that does not require a flow rate.

The GEM5000 calculates flow rate values specific to each device type (listed above). The available flow devices programmed in GEM mode are listed below.

## **Flow Devices:**

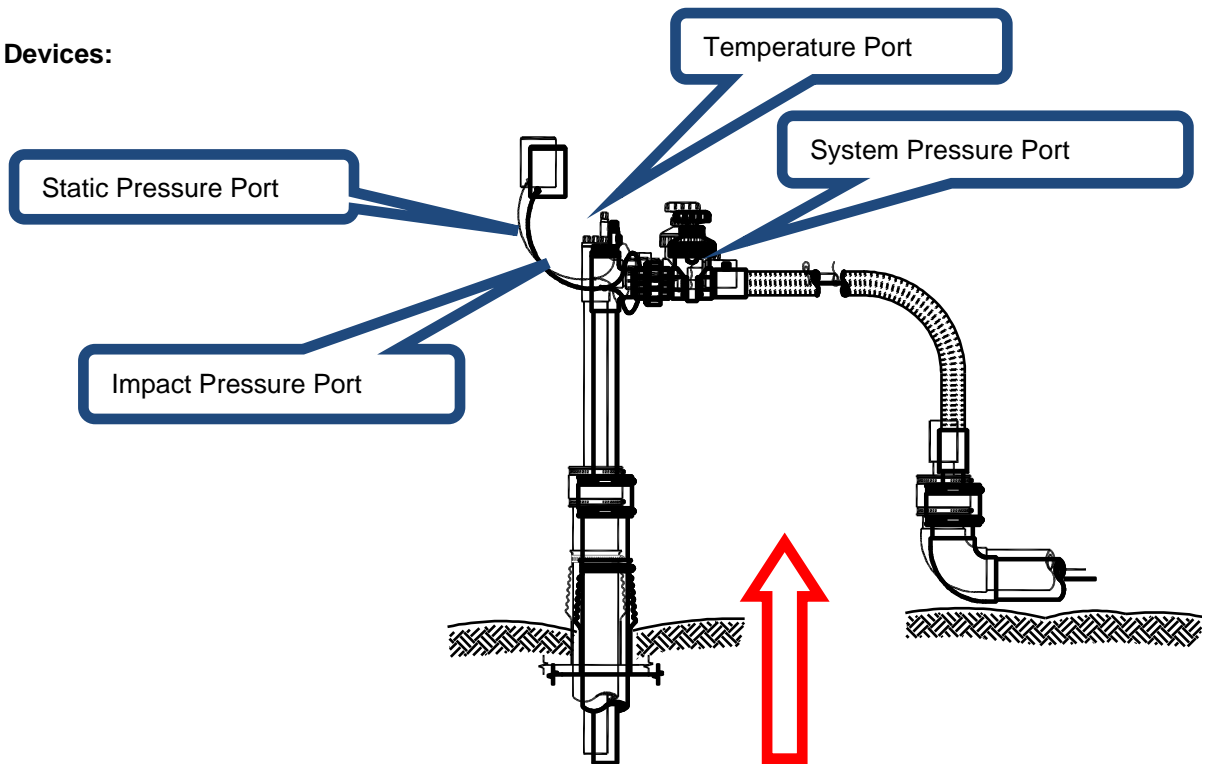

Figure 1 - ACCU-FLO Vertical Wellhead

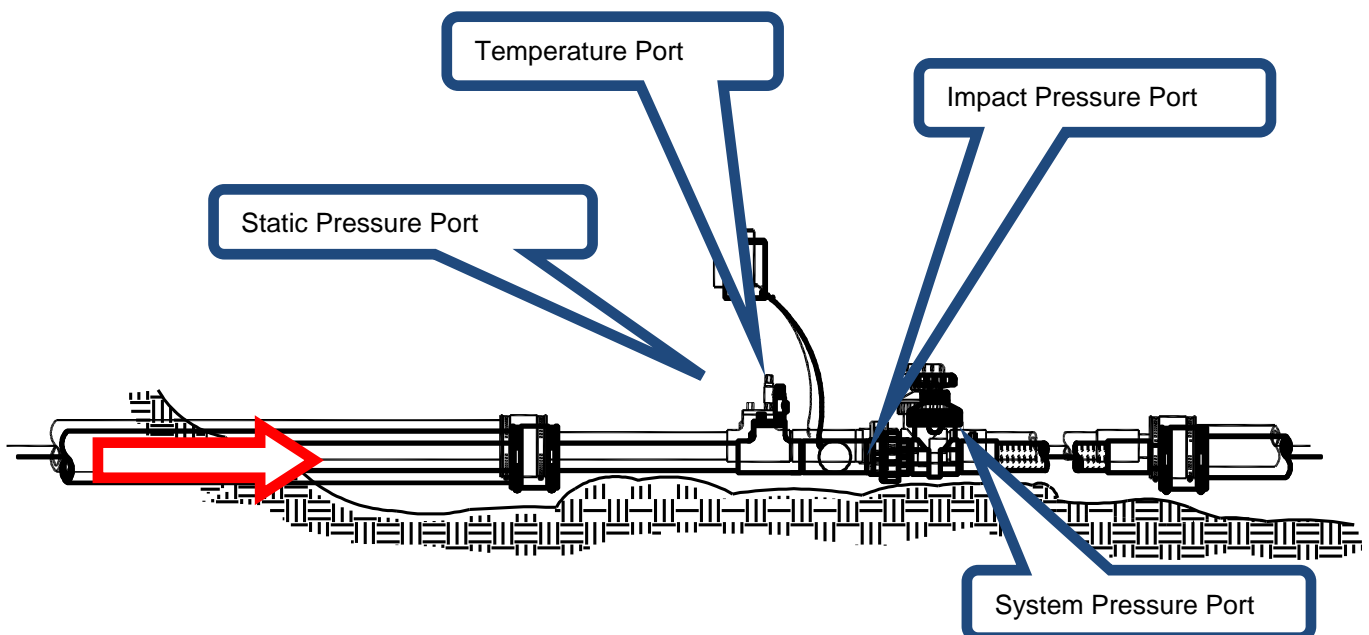

Figure 2 - ACCU-FLO Horizontal Wellhead

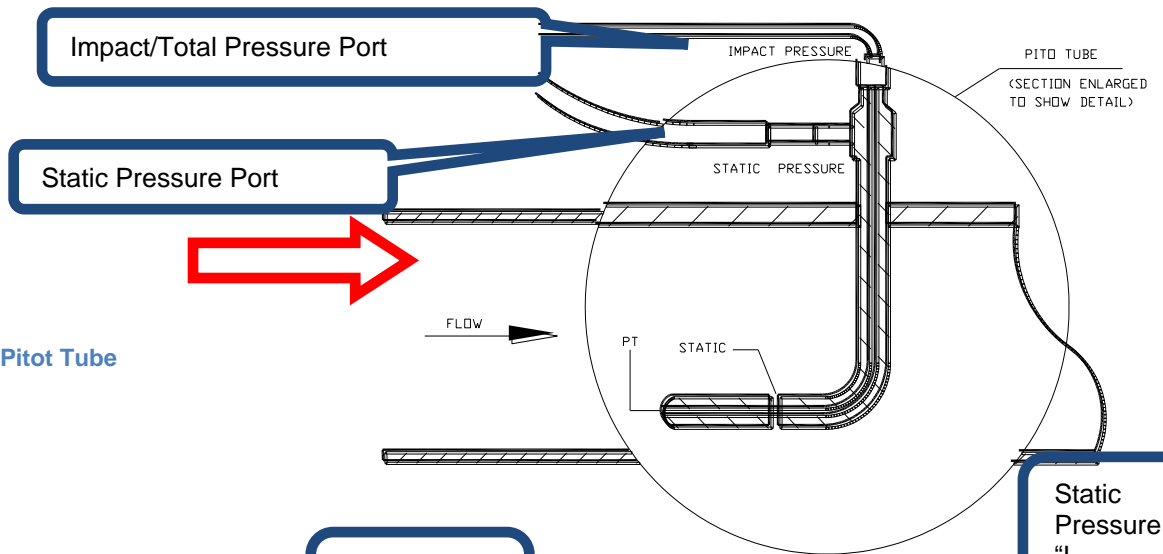

Figure 3 - Pitot Tube

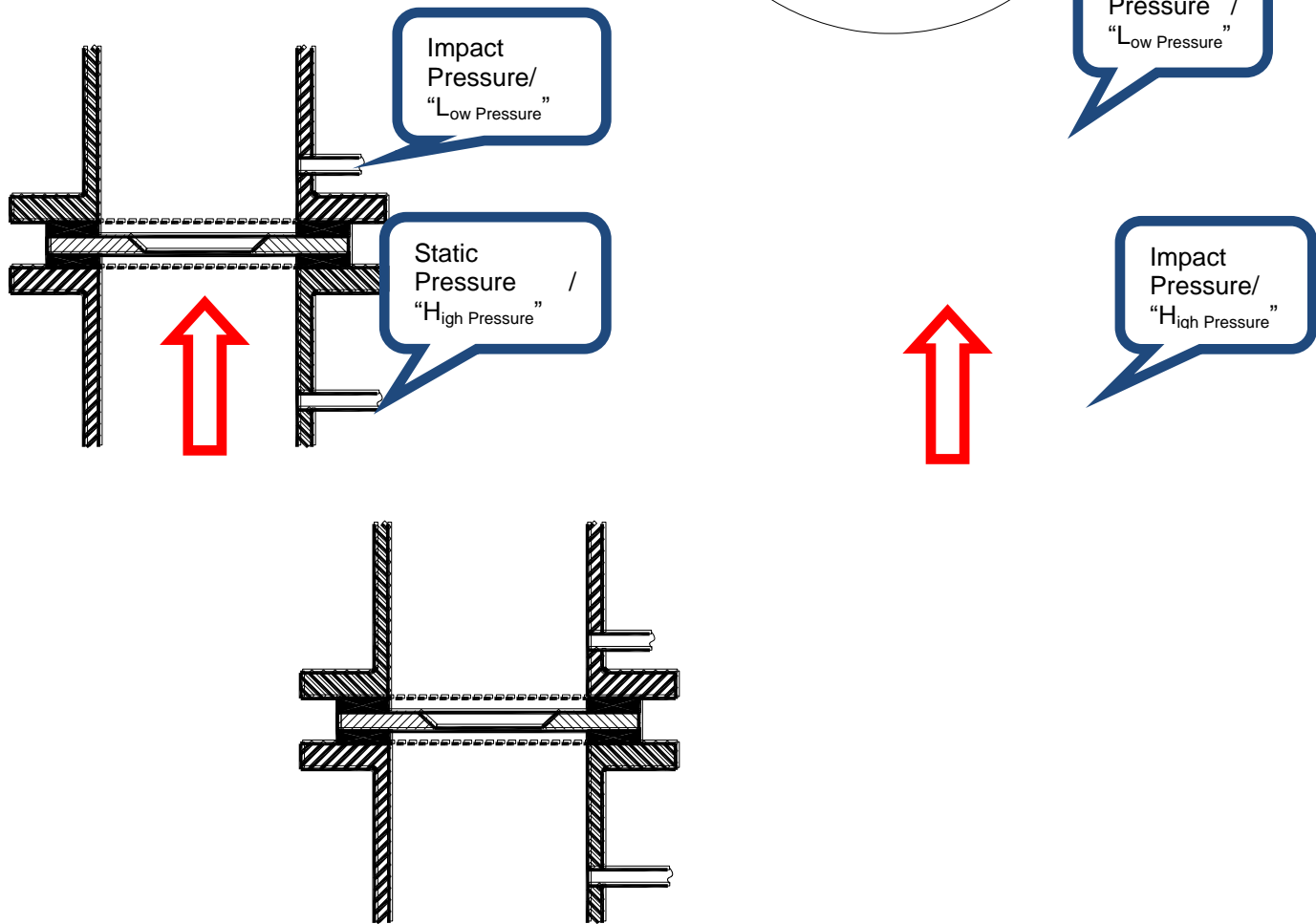

Figure 4 - Orifice Plate (WellSide)

Orifice Plate

# GEM5000 Gas Analyzer

Flow Device Name Programmed in GEM	Orientation	Size (Inches)	Flow Range (SCFM)	System Pressure
No Flow (GA Mode) *				
ACCU-FLO 1.0V	Vertical	1.0	1-25+	
ACCU-FLO 1.5V	Vertical	1.5	1-50+	
ACCU-FLO 1.5H	Horizontal	1.5	1-50+	
ACCU-FLO 2V	Vertical	2.0	5-125+	
ACCU-FLO 2H	Horizontal	2.0	5-125+	
ACCU-FLO 3V	Vertical	3.0	35-300+	
ACCU-FLO 3H	Horizontal	3.0	35-300+	
Orifice Plate				
Pitot Tube				
User Input				
Orifice Plate WellSide				
ACCU-FLO 1.0V	Vertical	1.0	1-25+	✓
ACCU-FLO-1.5V (System Pressure)	Vertical	1.5	1-50+	✓
ACCU-FLO-1.5H (System Pressure)	Horizontal	1.5	1-50+	✓
ACCU-FLO-2V (System Pressure)	Vertical	2.0	5-125+	✓
ACCU-FLO-2H (System Pressure)	Horizontal	2.0	5-125+	✓
ACCU-FLO-3V (System Pressure)	Vertical	3.0	35-300+	✓
ACCU-FLO-3H (System Pressure)	Horizontal	3.0	35-300+	✓
Orifice Plate-System Side (System Pressure)				✓
Pitot Tube (System Pressure)				✓
User Input (System Pressure)				✓
Orifice Plate WellSide (System Pressure)				✓

- \*Note: Use of the No Flow type of device on a Probe will allow the GEM5000 instrument to automatically switch to the GA workflow when the ID is selected. The user can always use special actions from the menu to switch workflows between GEM and GA.

**Pipe Diameter:** The pipe inside diameter (ID) is required for Orifice Plate and Pitot Tube type flow devices.

**Orifice Diameter:** The field for orifice bore diameter is available for all Orifice Plate flow devices.

*Note: For the instrument to calculate a flow the ratio of orifice size to pipe diameter must be between 0.25 and 0.75.*

**Pump Run Time:** Indicates the duration the instrument's pump will run while sampling for the selected ID.

**Device Information:** Allows the user to enter general information for the device. This will display on the screen of the instrument if the user chooses the  View ID Details option from the ID selection screen on the instrument.

## ID QUESTIONS

There are 5 Question Types that can be selected:

- **None** - No question will be prompted to the user
- **Alphanumeric** - An alphanumeric answer can be entered when taking a reading
- **Numeric** - A numeric only answer can be entered when taking a reading
- **Multiple Comment selection** - Up to 8 comments that may be appropriate for this device ID can be selected in the ID setup. Then one or all of the comments can be selected when taking a reading.
- **Single comment selection** - Up to 8 comments that may be appropriate for this device ID can be selected in the ID Setup but only one comment can be selected when taking a reading. Comments related to valve position are often used with a Single Comment Selection because the valve can only be in one position.

# GEM5000 Gas Analyzer

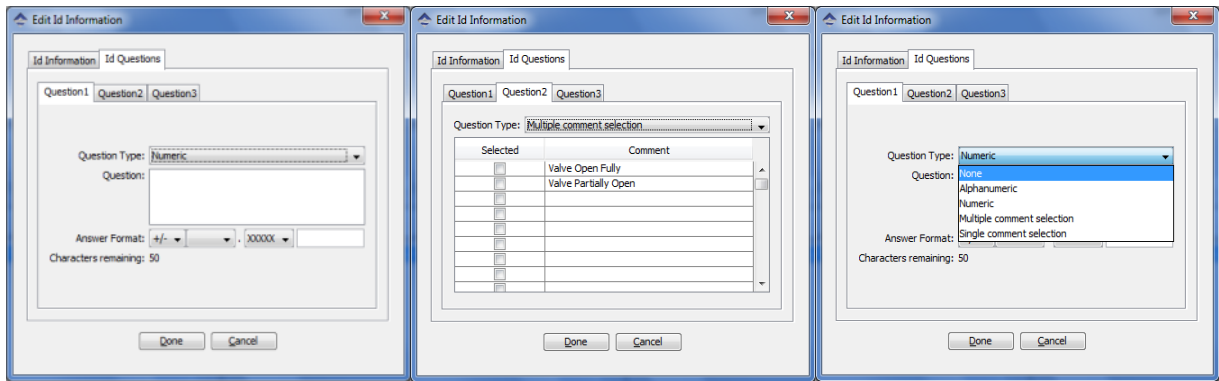

## 10.7.4 Importing Data Field CS ID's

If you have existing ID files from DataField CS v3.4.x, these files can be imported by LSGAM. To begin this operation select the **Import IDs...** option from the **Project** menu.

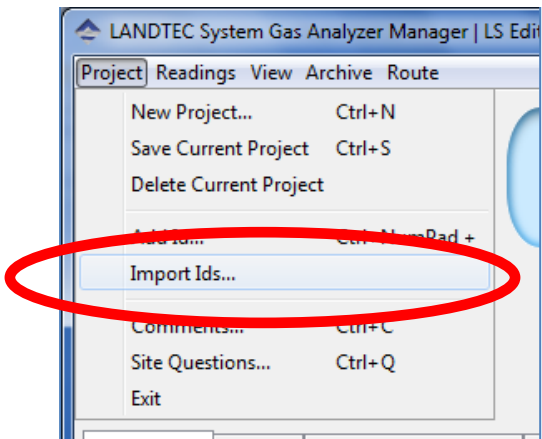

Select an ID file generated by DataField CS v3.4.x.

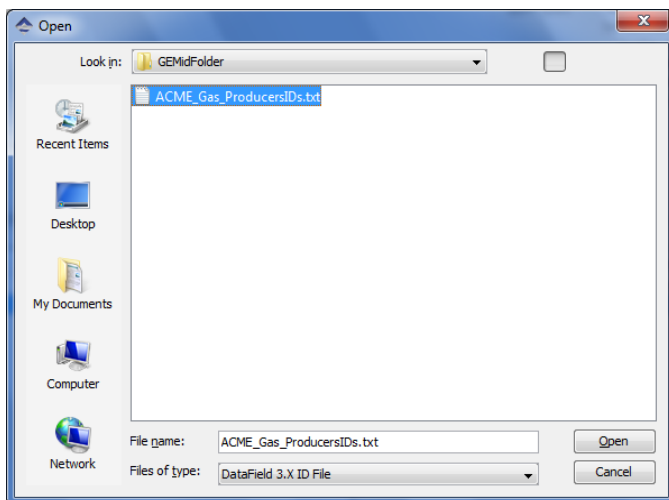

## 10.7.5 Creating a New Project (ID's already in instrument)

To create a Project based on the information in the instrument, select **Create a new project from the data in my instrument.**



# GEM5000 Gas Analyzer

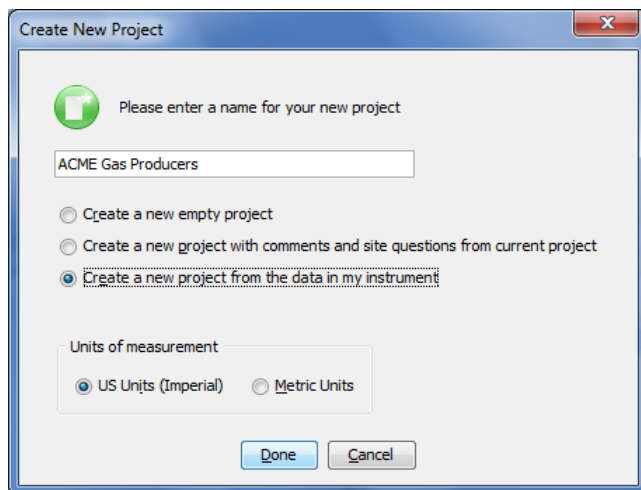

*Note: When using the **Creating a new project from the data in the instrument** option, only IDs NOT associated with other projects will be created into the new project.*

**Creating a Device ID that does not measure flow** Example- Probe or Sample Port

If there is no flow device you can choose the "No Flow (GA Mode)" option. Alternatively, you can also choose User Input. When choosing the User Input option you will need to enter the appropriate pipe inside diameter. A pump run-time must be specified in with either type of flow device.

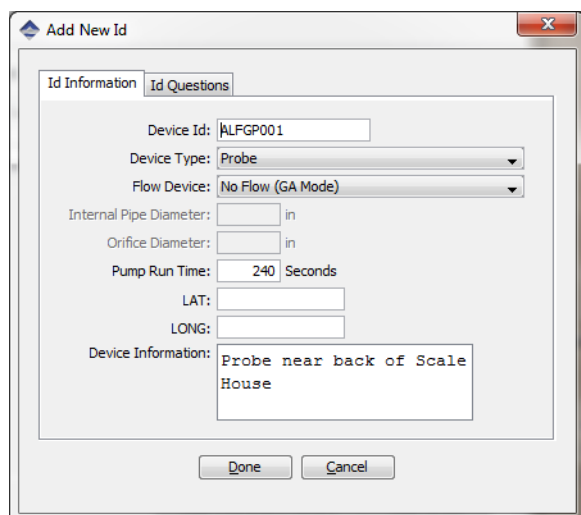

Figure 5—Probe Definition using "No Flow" option

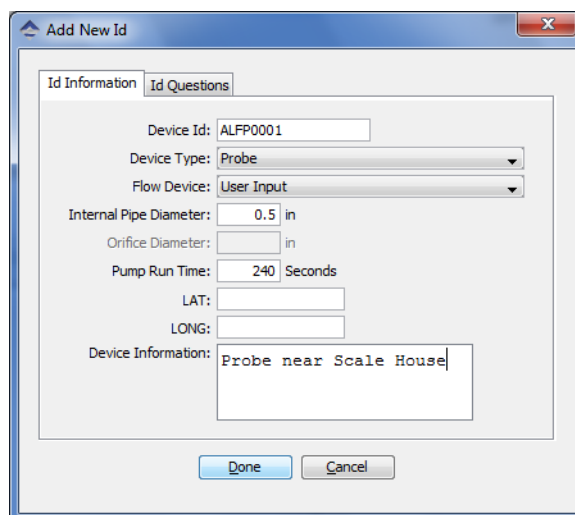

Figure 6—Probe Definition using "User Input"

## 10.7.6 Creating Site Questions

Site questions are setup in the same manner as ID questions however unlike ID questions, the answers for Site questions will apply to all subsequent readings until the site question is updated. A total of 5 site questions can be sent to your instrument. These must be updated each time you use the GEM. This is done by going to the ① Menu selection on the instrument and choosing [Update Site Data]

The options for questions are Alphanumeric – Numeric – Multiple or Single comment selection.

# GEM5000 Gas Analyzer

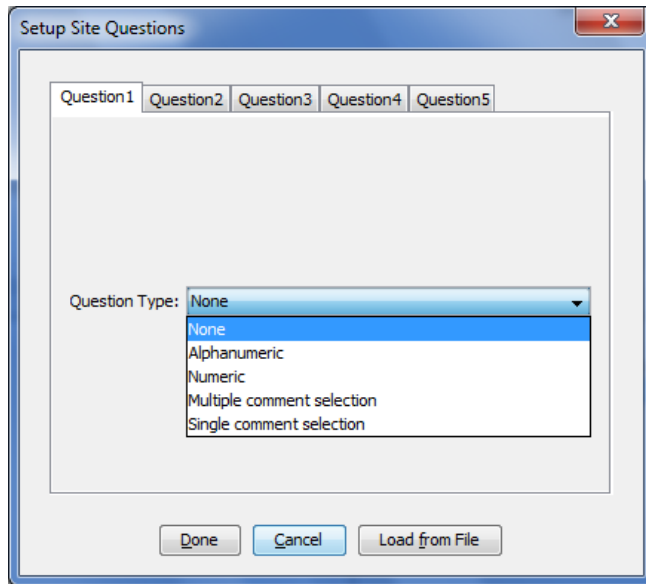

These Site Questions may be used again with another project by selecting the Create New Project and create new project with comments and **site questions** from current project.

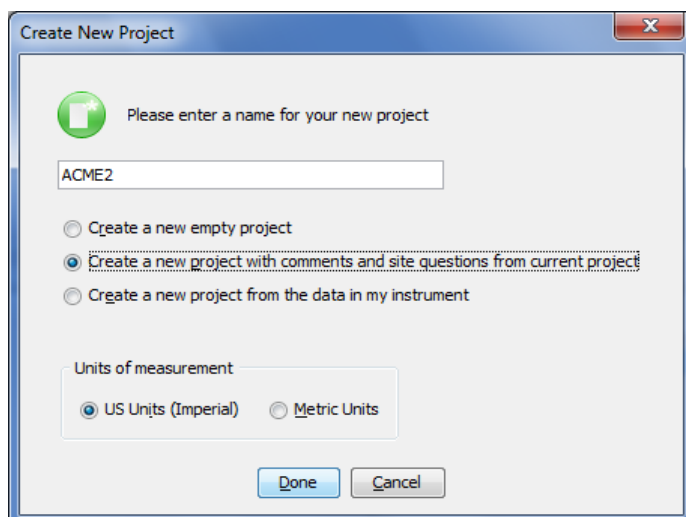
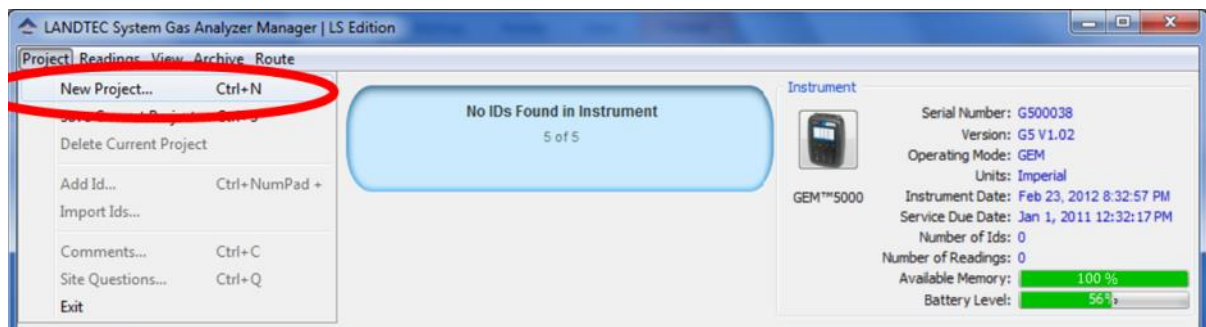

The project will be created and the IDs, Comments, and Site Questions that exist in the instrument will be applied to the new project.

# GEM5000 Gas Analyzer

## 10.7.7 Working with Device ID's

Once some IDs are added to your project you may need to occasionally edit them or reference them. First select the project which you want to work with from the project drop down list.

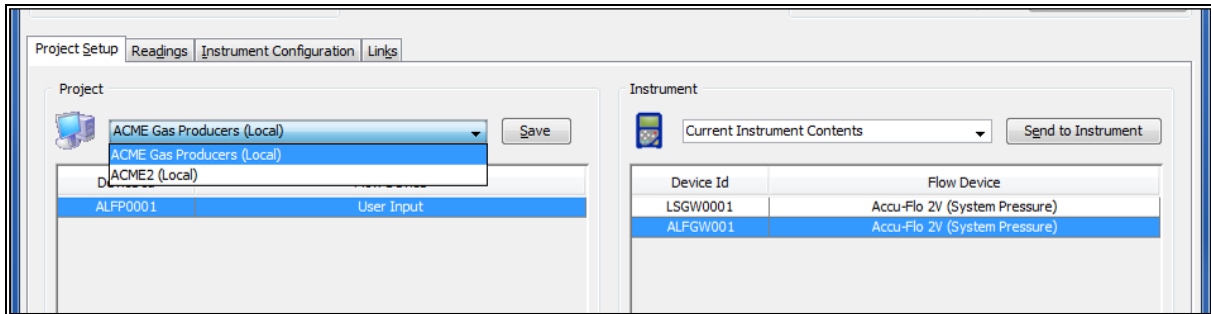

Placing the mouse cursor over a specific device ID will show detailed information about that ID.

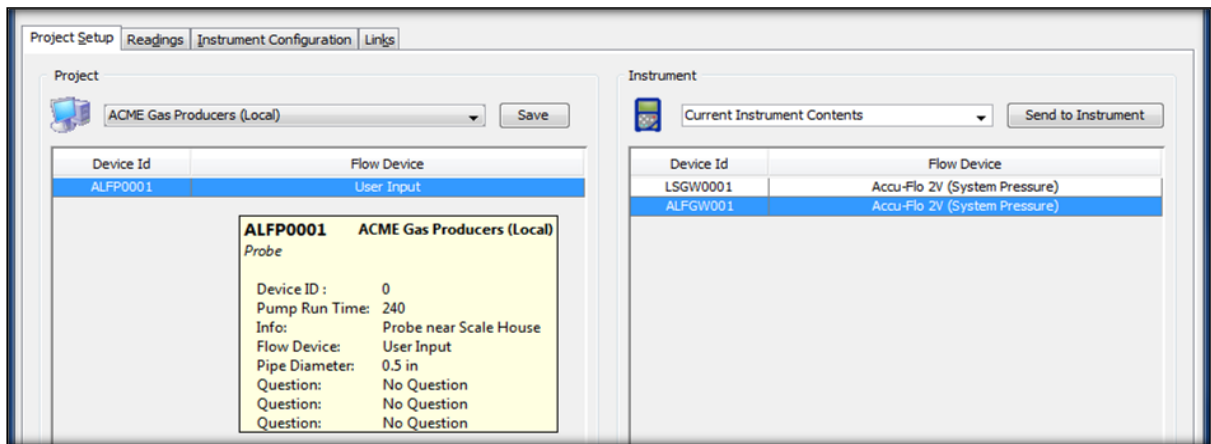

To edit a Device ID, right click on the desired device and select **Edit Device ID**.

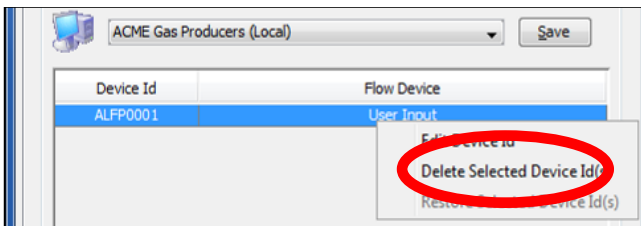

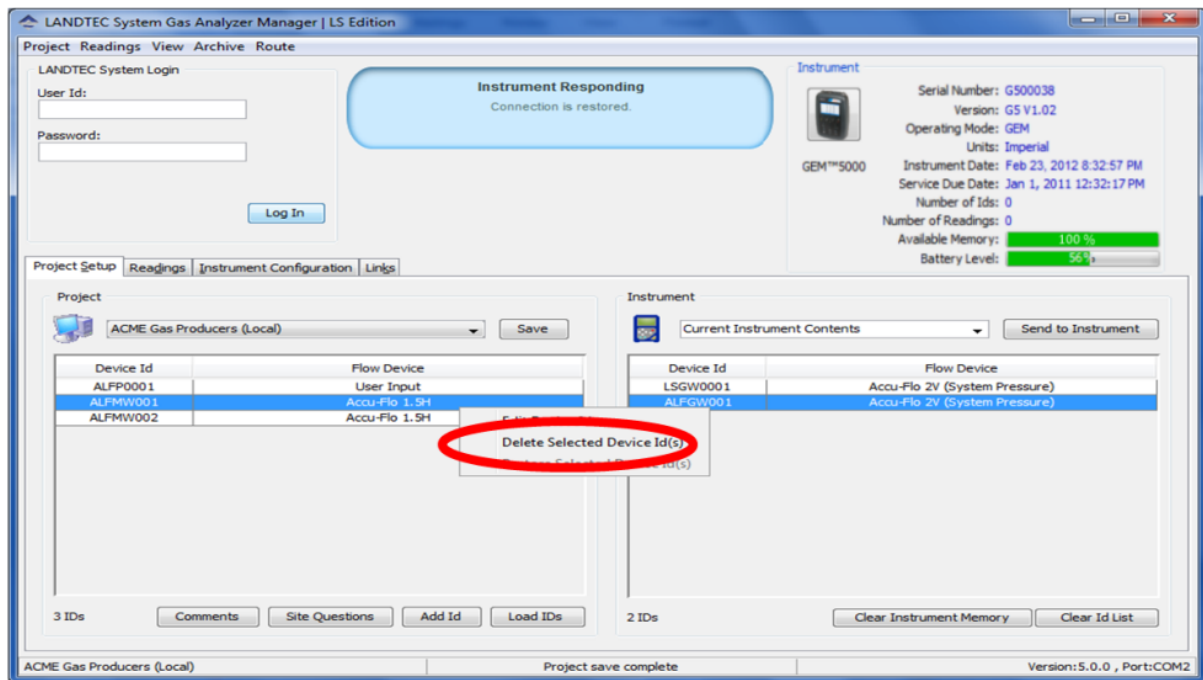

To delete an existing ID, right click on the desired device and select **Delete Selected Device ID(s)**.

# GEM5000 Gas Analyzer

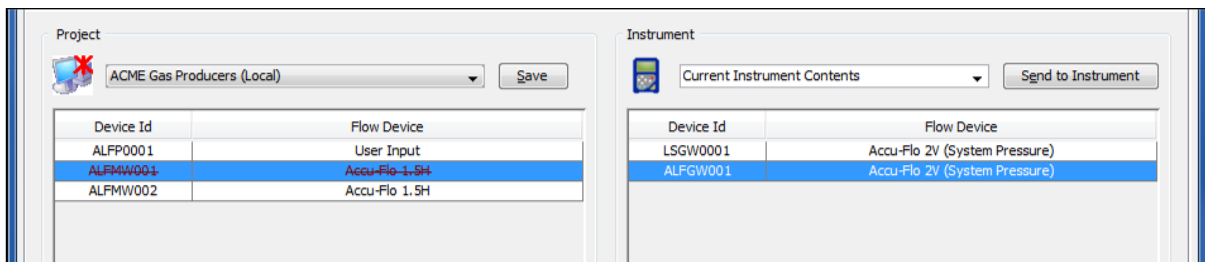

Upon clicking on Delete Selected Device Id(s) you will see the line ~~strikeout~~.



The computer icon will now display a red asterisk\* over the image . This indicates that the IDs are NOT saved. Deleted IDs are displayed with a line through the information on the screen. To restore a deleted ID, right click on the ID and click **Restore Selected Device ID(s)**.

*Note: Deleted ID's can only be restored while the project state is unsaved. Once saved, the ID changes are saved and restoration cannot be completed.*

Once all work with the device ID's is complete, click on the Save button.

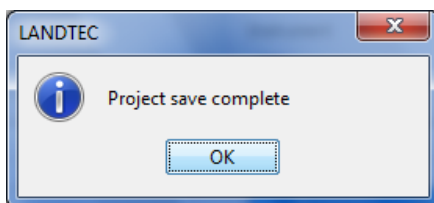

After clicking on OK, the device is removed and the computer icon returns to the unaltered state .

# GEM5000 Gas Analyzer

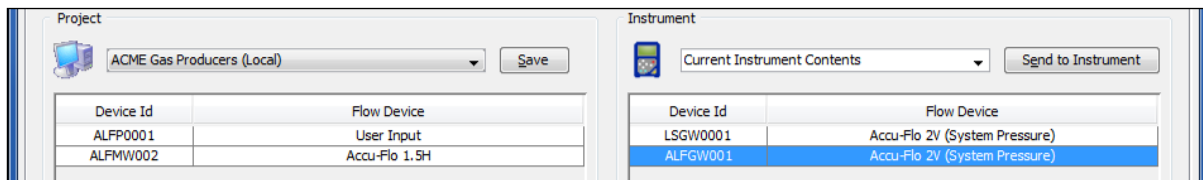

## 10.7.8 Sending ID's to the Instrument

Once IDs have been created in the project, they must be uploaded to the instrument. To perform this operation, select the desired IDs from the left hand table under the Project name (computer side), left click and hold while dragging the IDs to the right hand table and release the mouse button. This action is known as a "Drag & Drop".

Three basic methods of selecting IDs exist.



- Select Specific ID(s)
- Select a Range of IDs
- Select All IDs

### Specific IDs

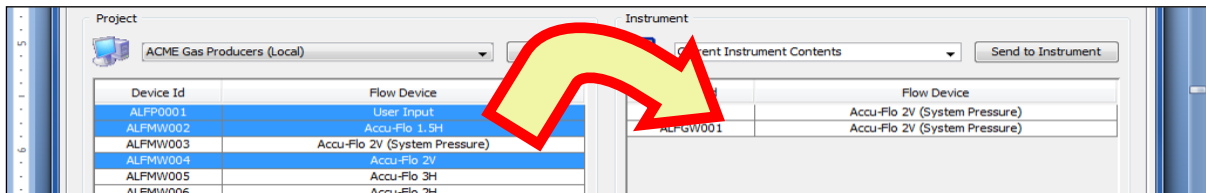

To Select Specific IDs from the List, place the mouse arrow  at the edge of the first cell and hold down the left Ctrl key. Now click the next ID cell that you wish to select. Repeat this as many times as necessary.

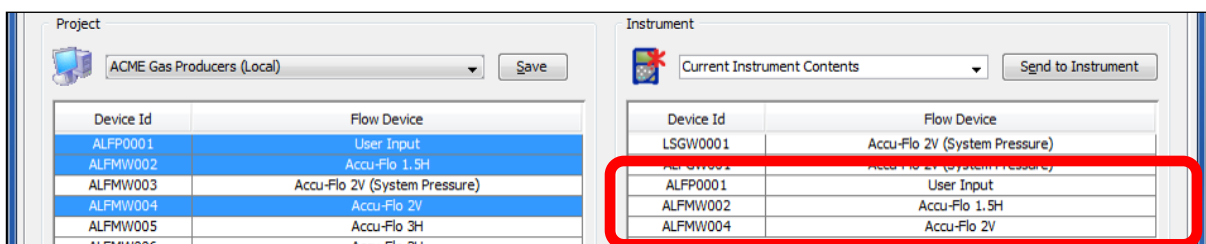

Selected IDs (shown as Highlighted). Arrow depicts "Drag & Drop" action after selection.

Now "Drag & Drop" the IDs from the left (computer window) to the right (instrument window). During the "Drag & Drop" process, the arrow  will change to .

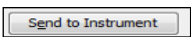

The selected IDs ALFP0001, ALFMW002, and ALFMW004 now appear on the Right (Instrument) side. At this point the IDs are on the Instrument side but have NOT been sent to the instrument. The instrument with the red asterisk   indicates this unsent ID state. Click on the Send to Instrument button  to send these IDs to the instrument.

# GEM5000 Gas Analyzer

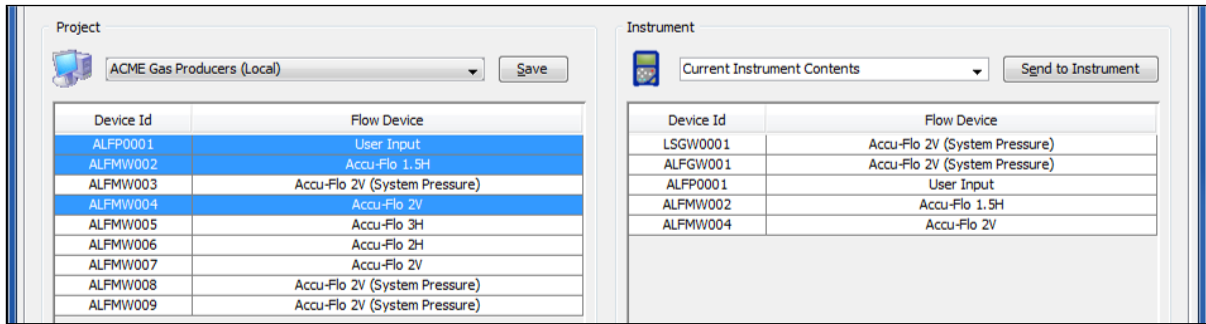

After the IDs are sent to the instrument, the instrument  will appear without the red asterisk\*

## Range of IDs

To Select A Range of IDs, place the mouse arrow at the edge of the first cell and hold down the left shift key. Now click the last cell in the range. The entire selected range will now be selected.

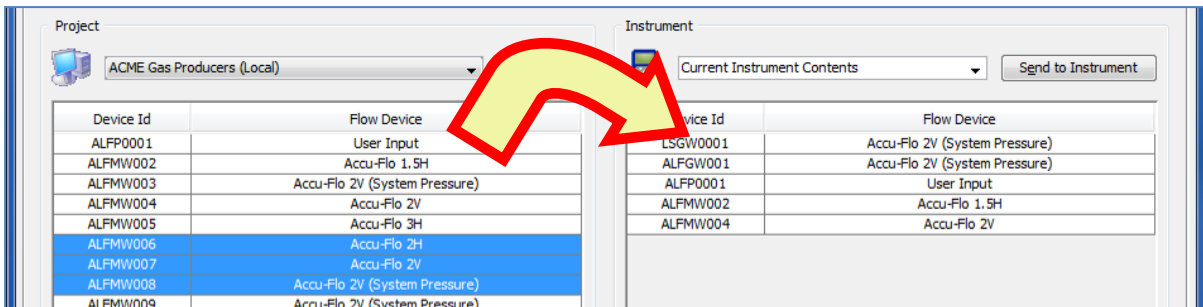

As with selecting specific IDs once the IDs are selected, they are moved to the Instrument side by "Drag & Drop". The Instrument icon will appear with a red \* and the ID's will need to be sent to the instrument.

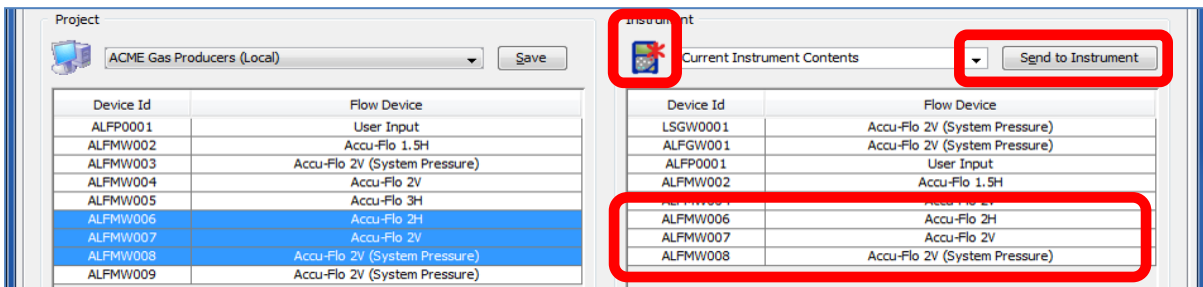

Click on the Send to Instrument button  to send these IDs to the instrument.

## Selecting All IDs

All IDs can be selected by selecting one ID in the Project window and then pressing Ctrl-A.

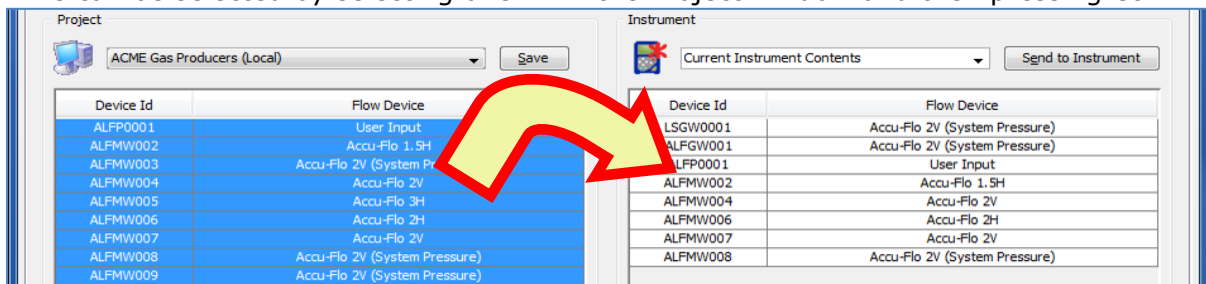

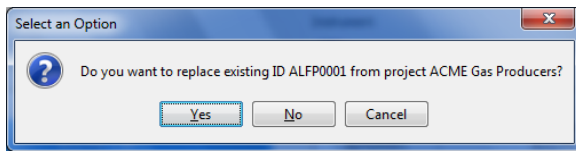

Now move IDs from the Project Side to the Instrument Side by dragging and dropping them.

# GEM5000 Gas Analyzer

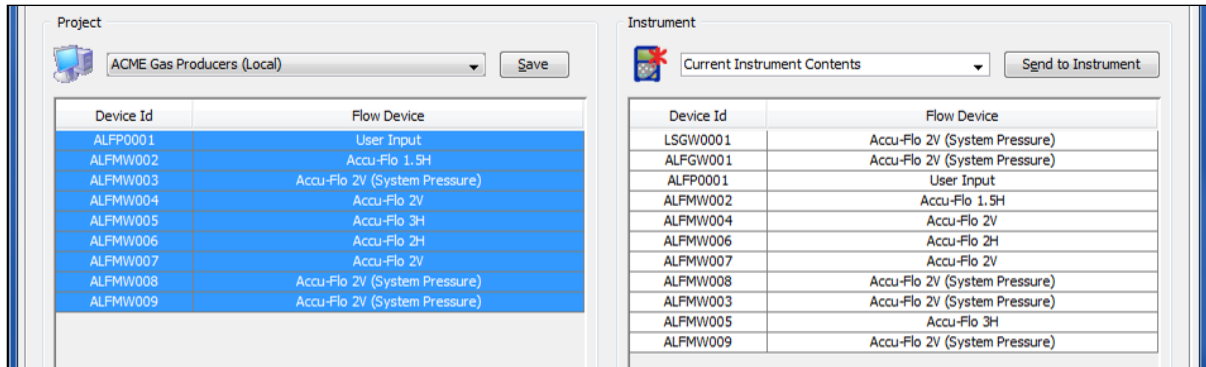

If you are dragging and dropping an ID that is already on the instrument side, you will be prompted with the above message. Answer Yes to update the IDs on the instrument side from those on the computer side. Answer No to ignore IDs that are already in the instrument. Answer Cancel to cancel the action without sending ID's to the instrument side.



Click on the Send to Instrument button  to send these IDs to the instrument.

## 10.7.9 Clearing ID's or Deleting a Project

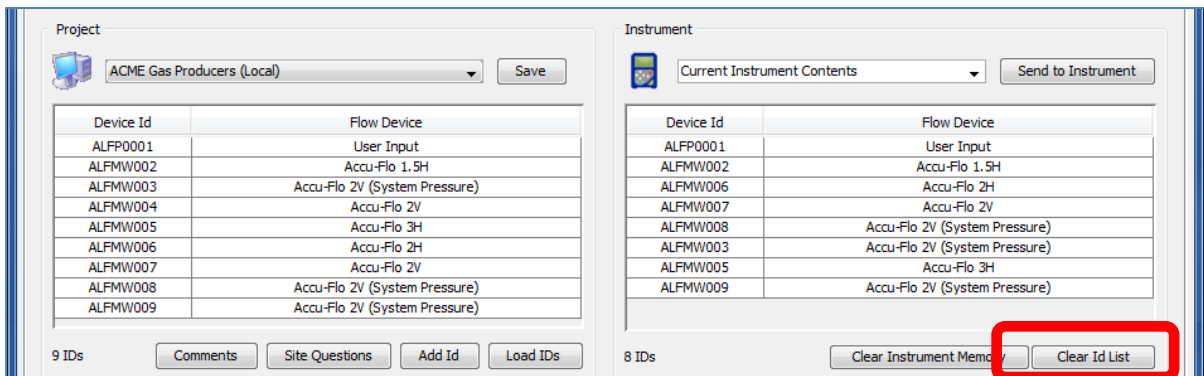

In current instrument contents when selecting the **Clear ID List** option, lines will be drawn through the IDs.

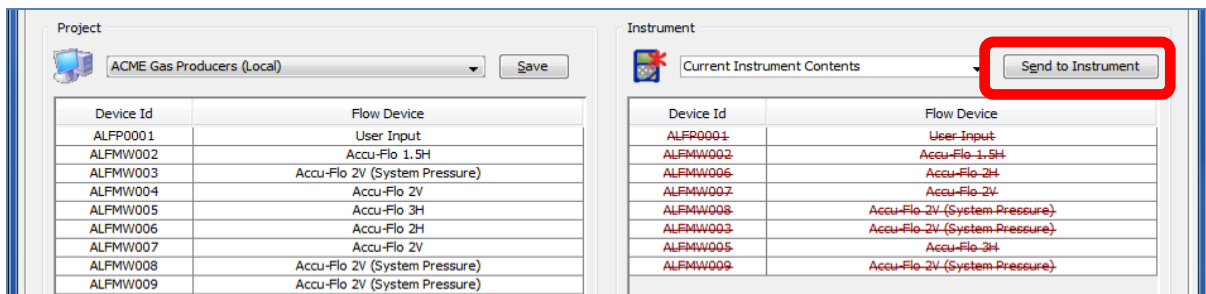

You then need to select **Send to Instrument**. This will clear all IDs from the instrument.

# GEM5000 Gas Analyzer

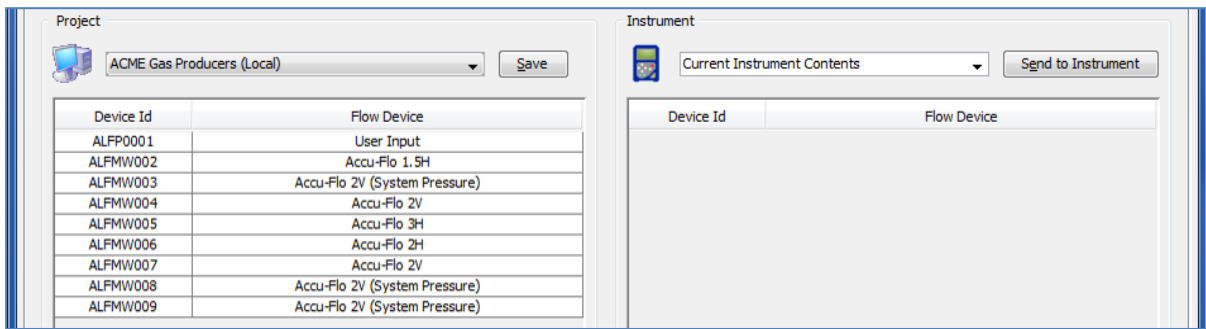

You may also delete one ID from a list by highlighting the ID **RIGHT CLICK** with your mouse and select the **Delete Selected Device** option. If you have selected the wrong ID and deleted then you may select the Restore option to return the ID to the list.

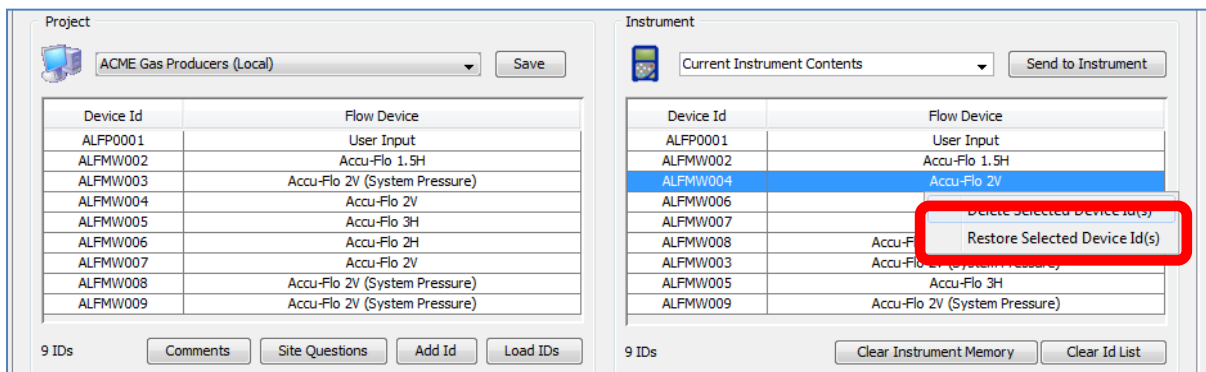

Upon selecting Delete Selected Device Id(s) you will see a ~~strikeout~~ line appear through the ID

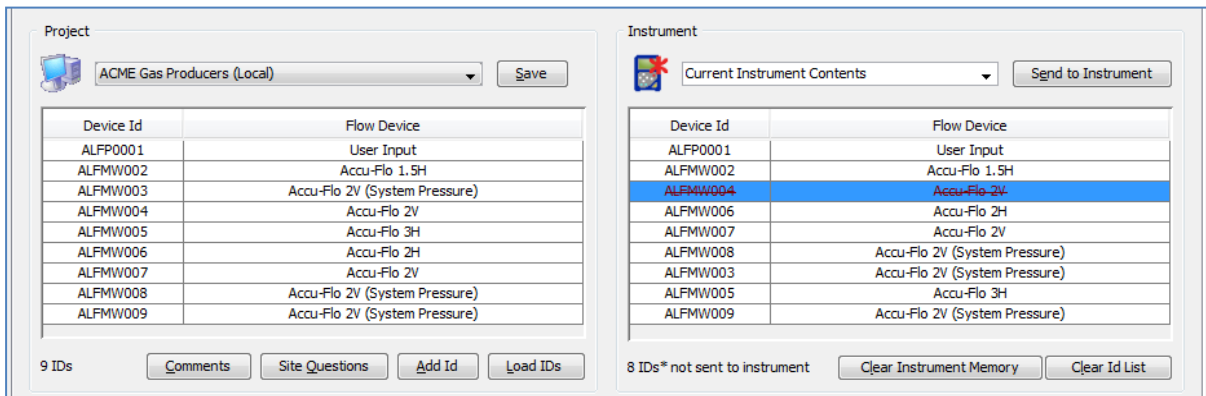

Click on the Send to Instrument button  to send the ID corrections to the instrument.

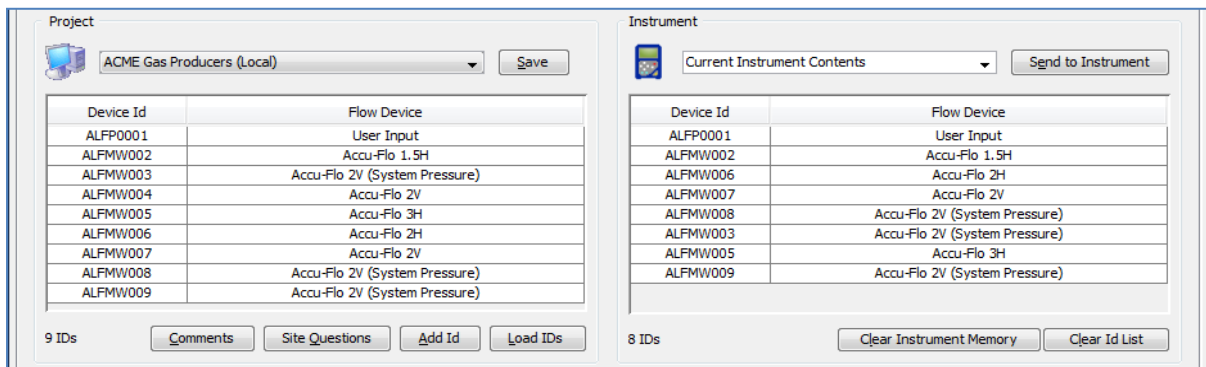

The instrument contents will now be updated and the ALFMW004 ID no longer shows in the instrument side of the list.

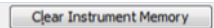

## 10.7.10 Clearing the Instrument Memory

The Clear Instrument Memory function  allows various parts of the instrument's memory to be cleared. Upon clicking on the **Clear Instrument Memory** button the following options are available.

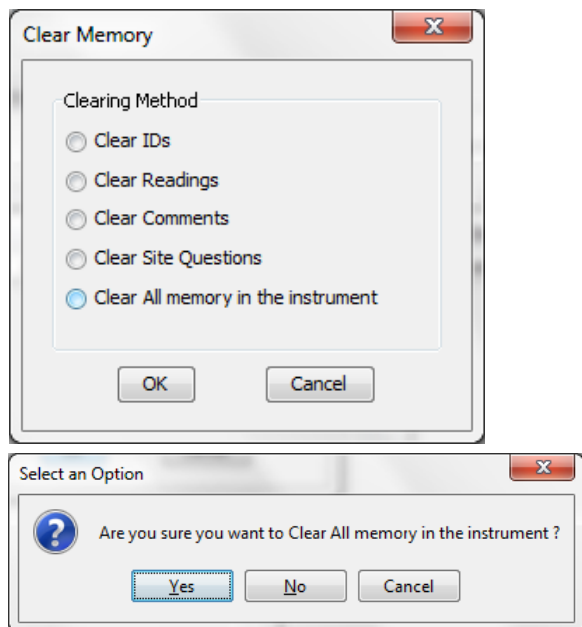

Answer **Yes** to perform the action.  
Answer **No** or Cancel to return to the clear memory dialog.

### 10.7.10.1 "Cold Start"

A "Cold Start" of the 5000 instrument is a way to reset the instrument and purge all non-factory information from the instrument. A cold start will PERMANENTLY DELETE readings, calibration events, IDs, and technician information from your instrument. Under normal operating conditions, instruments should NOT need to be Cold Started. Due to technical reasons, Cold Starting a GEM5000 is the only means of clearing technician information from the instrument.

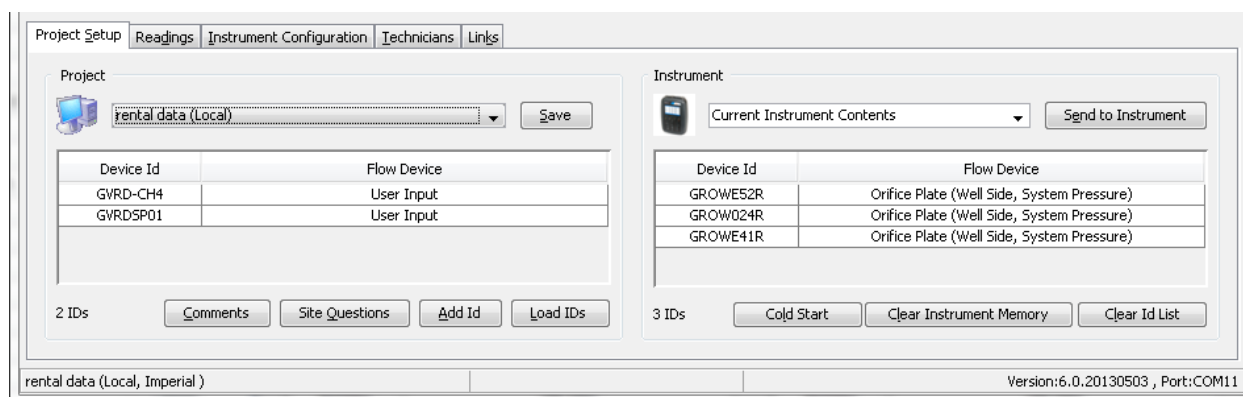

Upon clicking the  button a confirmation screen will appear. Click NO to abort the Cold Start operation, Click Yes to perform the cold start.

# GEM5000 Gas Analyzer

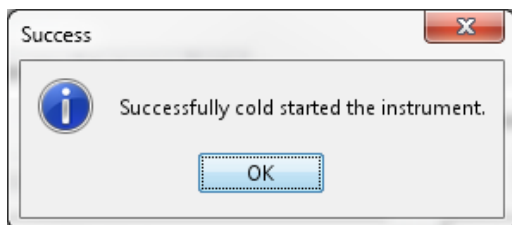
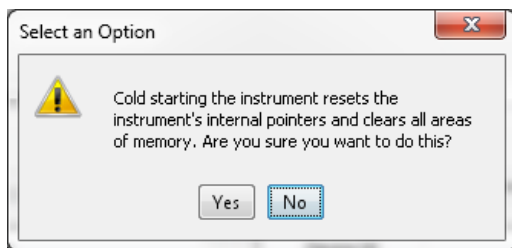

## 10.7.11 Instrument Settings

The LANDTEC System Gas Analyzer Manager software allows users to change many of the operational settings of the instrument. To view and change the available settings click on the **Instrument Configuration** tab.

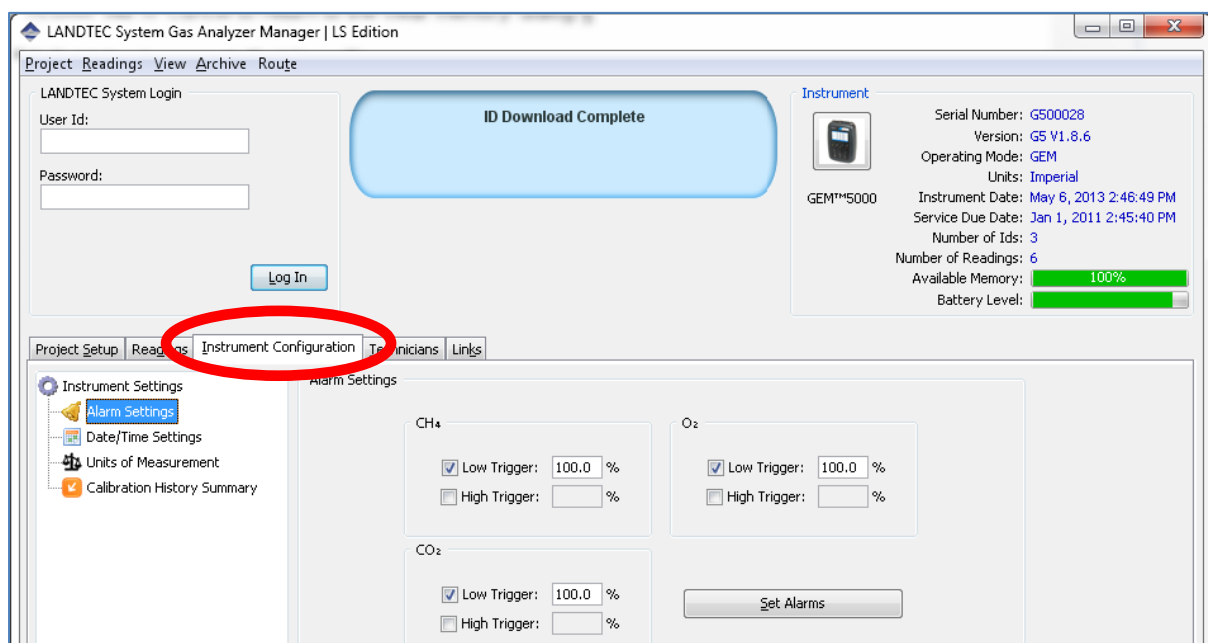

In the Instrument Configuration user interface, there is an Instrument Settings option tree. The Instrument Settings tree allows for easy navigation to the following categories:

- **Alarm Settings**
- **Date/Time Settings**
- **Misc Options (GEM-2000 only)**
- **Units of Measurement**
- **Calibration History Summary (GEM5000 only)**

The following sections describe each option category.

# GEM5000 Gas Analyzer

## 10.7.12 Alarm Settings

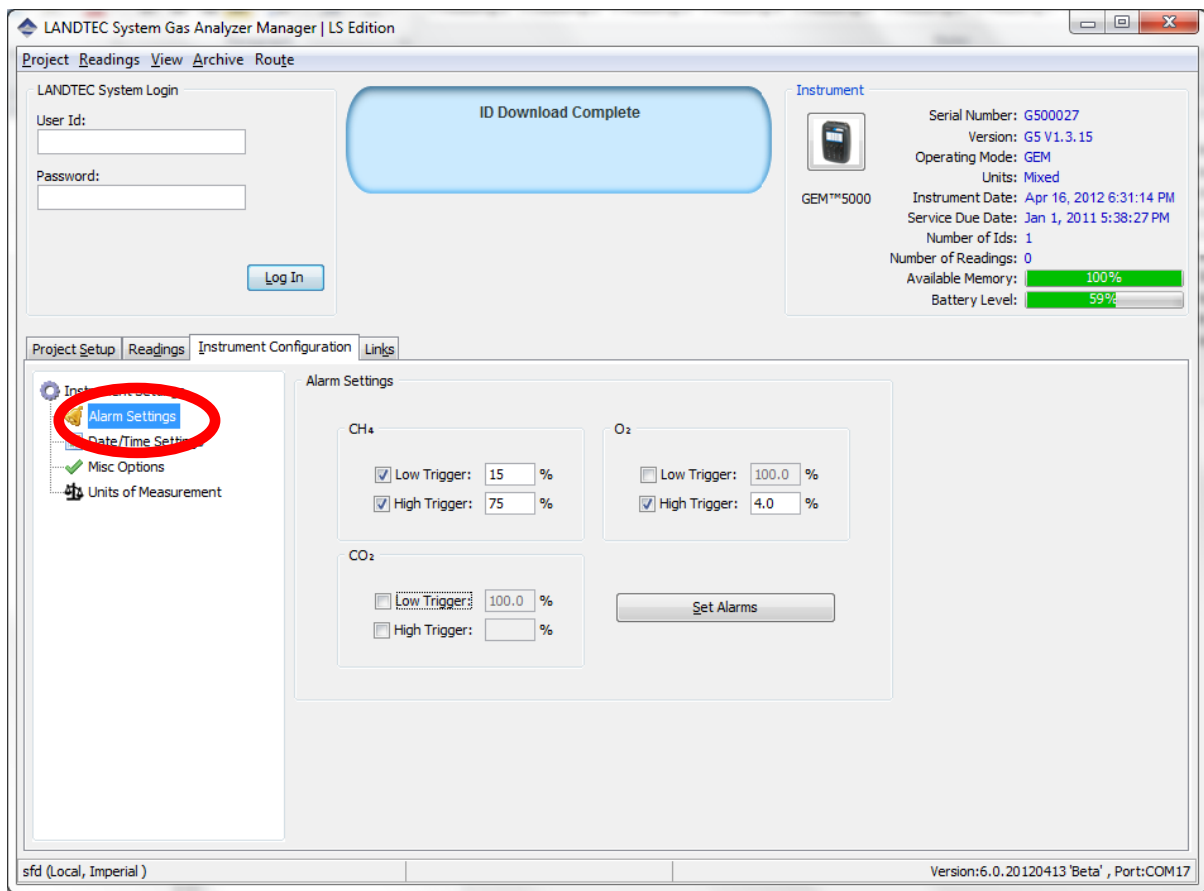

The Alarm Settings options control the activation and deactivation of the audible alarms in the instrument. Audible alarms can be configured for CH<sub>4</sub>, CO<sub>2</sub>, and O<sub>2</sub> parameters (additional gases present on plus model instrument). Each parameter can be configured with a Low Trigger and/or High Trigger for the alarm. To activate any specific alarm, click and place a checkmark in the desired box. This will activate the entry field to place the value. The values must be 0 – 100 percent. When alarms are set, the instrument will highlight the composition component in orange on the 5000 instrument on the 2000 instrument it will beep and flash the parameter on the screen if an alarm threshold is surpassed when taking a gas reading. Refer to the section titled “Set Alarms” for additional options that are available for setting alarms directly on the 5000’s instrument.

Channel	Adjusted	Initial	Previous	Units
CH <sub>4</sub>	0.0	0.0	0.0	%
CO <sub>2</sub>	0.1	0.1	0.1	%
O <sub>2</sub>	20.1	20.1	20.1	%
Bal.	79.8	79.8	79.8	%
Static.P			----	"H <sub>2</sub> O
Diff.P			----	"H <sub>2</sub> O
Temp.	76.3	76.2	76.3	°F
Flow	3333.3	2222.2	3333.3	SCFM
Power	0.0	0.0	0.0	BTU/h

Figure 7—Alarm Highlighting Example

## Date/Time Settings

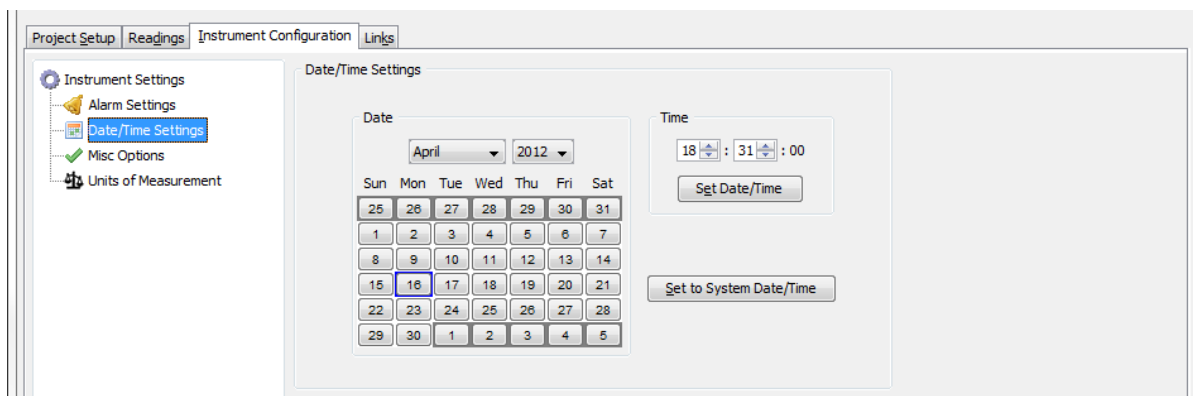

The **Date/Time Settings** screen allows the user to set the date and time of the instrument.

### Setting the Computer's Date and Time

To set the instrument's date and time to that of the computer, click on the Set to System Date/Time button.

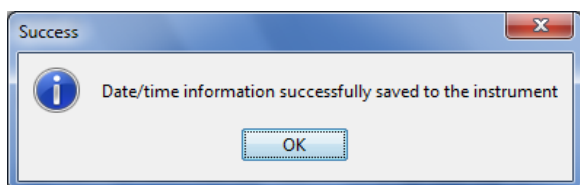

Answer OK and the instrument's date/time will be set to that of the computer.

### Date

Use the calendar options to select the desired date.

### Time

Use the up and down controls to select the desired hour and minutes.

### Set Date/Time in the instrument

Click the Set Date/Time button to apply the settings to the instrument

## 10.7.13 Misc Options

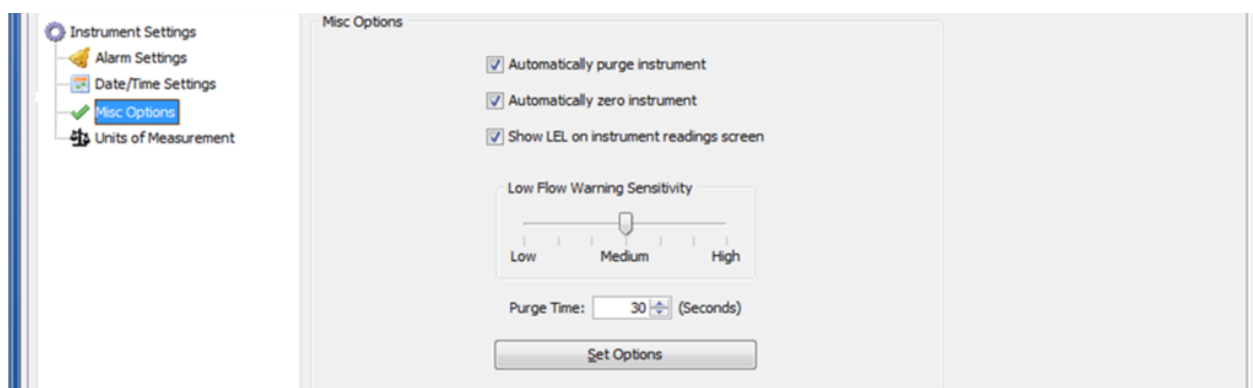

Under the miscellaneous options interface the user can change the following instrument settings:

#### Automatically purge instrument

Activates and deactivates the automatic purge feature in the instrument

#### Automatically zero instrument

Activates and deactivates the automatic zero feature in the instrument

# GEM5000 Gas Analyzer

## Low Flow Warning

Specifies the point at which the instrument will “Flow Fail”. If the instrument detects that it is not able to extract the appropriate gas flow for analysis the word “Flow” will flash in the upper left part of the screen where the pump timer is normally shown. If flow does not increase the pump will automatically be stopped. Adjusting the setting to “Low” will allow the pump to run with less flow going through the instrument. This may help avoid flow fail conditions when sampling from high vacuum systems.

## Purge Time

Specifies the duration the pump will run when activated by the purge feature of the instrument.

## 10.7.14 Units of Measurement

The screenshot shows the LANDTEC System Gas Analyzer Manager | LS Edition software interface. The main window has a menu bar with 'Project', 'Readings', 'View', 'Archive', and 'Route'. Below the menu bar, there is a 'LANDTEC System Login' section with 'User Id:' and 'Password:' input fields and a 'Log In' button. A large blue button in the center says 'ID Download Complete'. To the right, the 'Instrument' section displays details for GEM5000, including Serial Number: G500028, Version: G5 V1.8.6, Operating Mode: GEM, Units: Imperial, Instrument Date: May 6, 2013 2:54:16 PM, Service Due Date: Jan 1, 2011 2:45:40 PM, Number of Ids: 3, Number of Readings: 6, Available Memory: 100%, and Battery Level: 100%. The 'Instrument Configuration' tab is selected, and the 'Units of Measurement' sub-tab is active. A table allows selecting between Metric and Imperial (USA) units for various parameters. The 'Set Units' button is at the bottom.

	<input type="radio"/> Metric	<input checked="" type="radio"/> Imperial (USA)
Transducer Pressure:	Millibars (mb)	Inches water ("H2O)
Barometric Pressure:	Millibars (mb)	Inches mercury ("Hg)
Temperature:	Degrees Celsius (°C)	Degrees Fahrenheit (°F)
Flow:	Meters cubed per hour (m³/h)	Standard cubic feet/min (SCFM)
Power:	Kilowatts (KW)	British Thermal Units (BTU)
Anemometer:	Meters per second (m/s)	Meters cubed per hour (m³/h)
Internal Pipe Diameter:	Millimeters (mm)	Inches (")

This is a duplicate of the screenshot above, showing the same LANDTEC System Gas Analyzer Manager | LS Edition software interface with the 'Units of Measurement' configuration screen active.

# GEM5000 Gas Analyzer

---

The Units of Measurement interface allows users to select whether to operate the instrument in metric or imperial units. The units for each parameter are displayed on the screen.

**WARNING:** *Units of Measure are as critical as the values of the readings stored. Be certain to verify the appropriate Units of Measure for your project prior to making a change to this option. Changing the Units of Measure will **NOT** convert any existing values stored in the instrument. To avoid confusion, download any stored readings prior to changing the Units of Measurement.*

Clicking on the Set Units button will bring up the Change Units Password box. If you must change the units of measure please call LANDTEC's Software Support for a password.

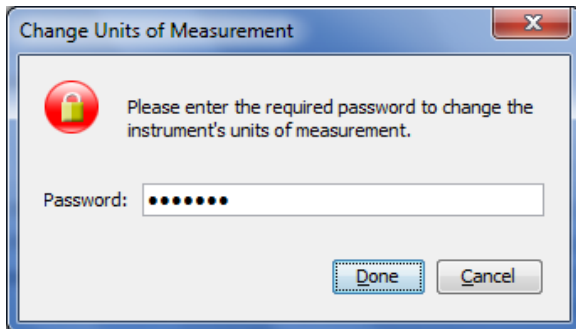

Upon entering the password you'll be prompted one last time to download your data from the instrument. If you have not downloaded your instrument press the **No** or **Cancel** buttons. Click Yes only if you have all data from your instrument as changing the units of measure must erase data that is in the instrument to ensure data integrity.

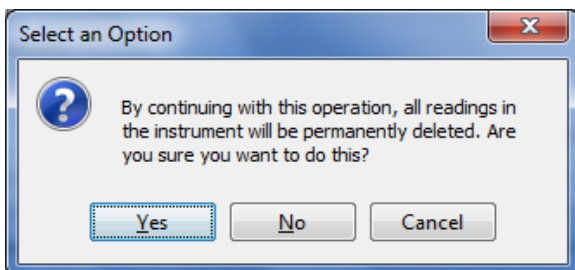

# GEM5000 Gas Analyzer

## Calibration History Summary

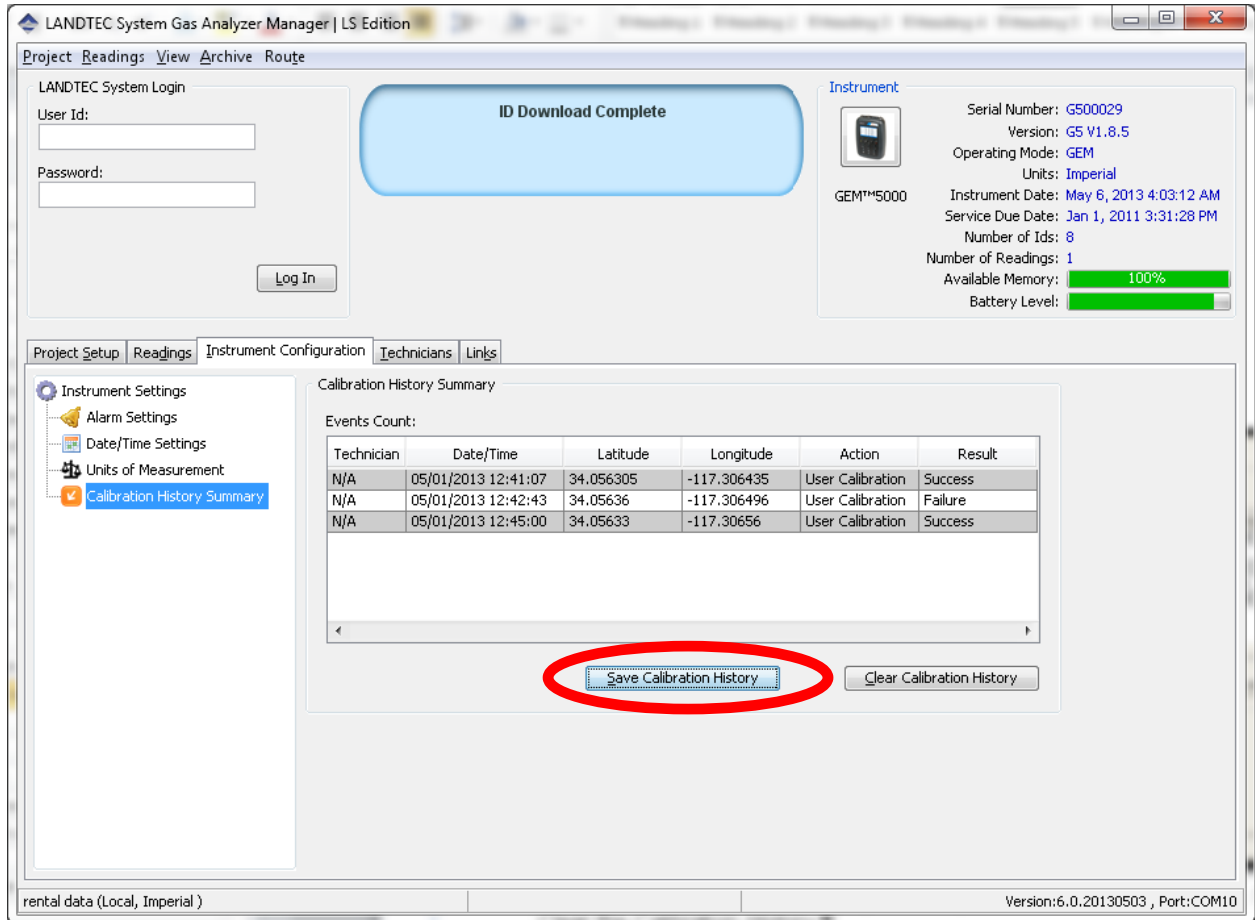

The Calibration History Summary allows you to view the calibrations, Save the Calibration History and Clear the Calibration History.

Viewing the calibration history can be done simply by clicking on "Calibration History Summary" option within the Instrument Configuration tab

Saving the calibration history to file can be accomplished by clicking on the  button. Upon clicking the Save button. You will be prompted for a directory location and file name for storing file.

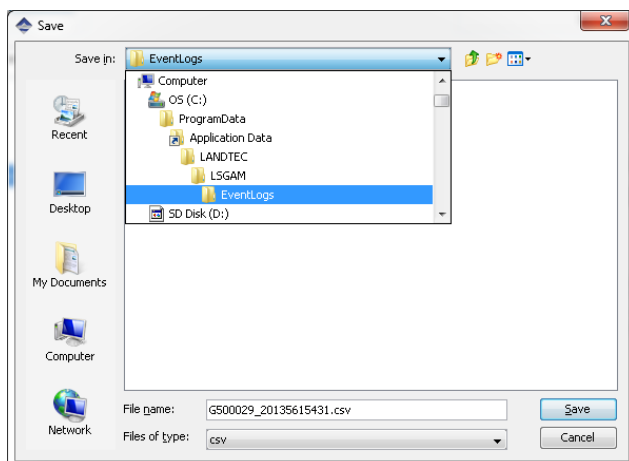

The directory location varies depending upon your operating system. In Windows 7 & 8 it is in

**C:\ProgramData\LANDTEC\LSGAM\EventLogs**

On Windows XP the directory defaults to

# GEM5000 Gas Analyzer

C:\Documents and settings\All Users\Application Data\LANDTEC\EventLogs

These directories may be hidden on your computer. If so, please type the directory name into the Run or Search Box.

Upon opening the .CSV file you'll notice the following fields:

- Technician
- Date Time
- Lat
- Long
- Action
- Result

The following fields are repeated for each gas composition component (CH<sub>4</sub>, CO<sub>2</sub>, O<sub>2</sub>, H<sub>2</sub>S, CO, Etc...)

- Channel
- Before
- After
- Span Target
- Status

For illustrative purposes only these have been colored in the following example.

	A	B	C	D	E	F	G	H	I	J	K	L	M	N	O	P	Q	
1	Technician	Date Time	LAT	LONG	Action	Result	Channel	Before	After	Span Target	Status	Channel	Before	After	Span Target	Status	Channel	Before
2	N/A	5/1/2013 12:41	34.056305	-117.306435	User Calibration	Success	CH4	-0.072369404	-0.003705339	0	Passed	O2	20.160007	20.9	20.9	Passed	CO	0.201
3	N/A	5/1/2013 12:42	34.05636	-117.306496	User Calibration	Failure	CH4	-0.008667287	-0.008667287	50	Failed	CO2	0.14623539	0.14623539	35	Failed	O2	20.8
4	N/A	5/1/2013 12:45	34.05633	-117.30656	User Calibration	Success	O2	20.855478	20.9	20.9	Passed	N/A	N/A	N/A	N/A	N/A	N/A	N/A

Figure 8—Calibration Information spread sheet Example

Each row of the spread sheet represents one calibration or gas check event on the instrument. A total of 7 sets of Channel, Before, After, Span Target and Status Columns are included on the spread sheet. Unused channel data will contain N/A

AF	AG	AH	AI	AJ	AK	AL	AM	AN	AO
Channel	Before	After	Span Target	Status	Channel	Before	After	Span Target	Status
N/A	N/A	N/A	N/A	N/A	N/A	N/A	N/A	N/A	N/A
N/A	N/A	N/A	N/A	N/A	N/A	N/A	N/A	N/A	N/A
N/A	N/A	N/A	N/A	N/A	N/A	N/A	N/A	N/A	N/A

Figure 9—Unused Gas Components in Calibration Record

## 10.7.15 Downloading Readings

After successfully creating projects, IDs, and setting appropriate instrument settings, the instrument is ready for field use. When used in the field, **readings** are collected and stored within the instrument's memory. The readings consist of the measured, input, and calculated parameters such as CH<sub>4</sub>, CO<sub>2</sub>, O<sub>2</sub>, Gas Temperature, Flow Rate, etc. These readings must be downloaded from the instrument to be reviewed on the computer and stored for review at a later time. This section of the Operation Manual reviews the process of downloading and storing readings from the instrument.

To view your readings from the instrument, select the Readings tab of the LANDTEC System Gas Analyzer Span Manager software. Then click on the **Get Readings** button



# GEM5000 Gas Analyzer

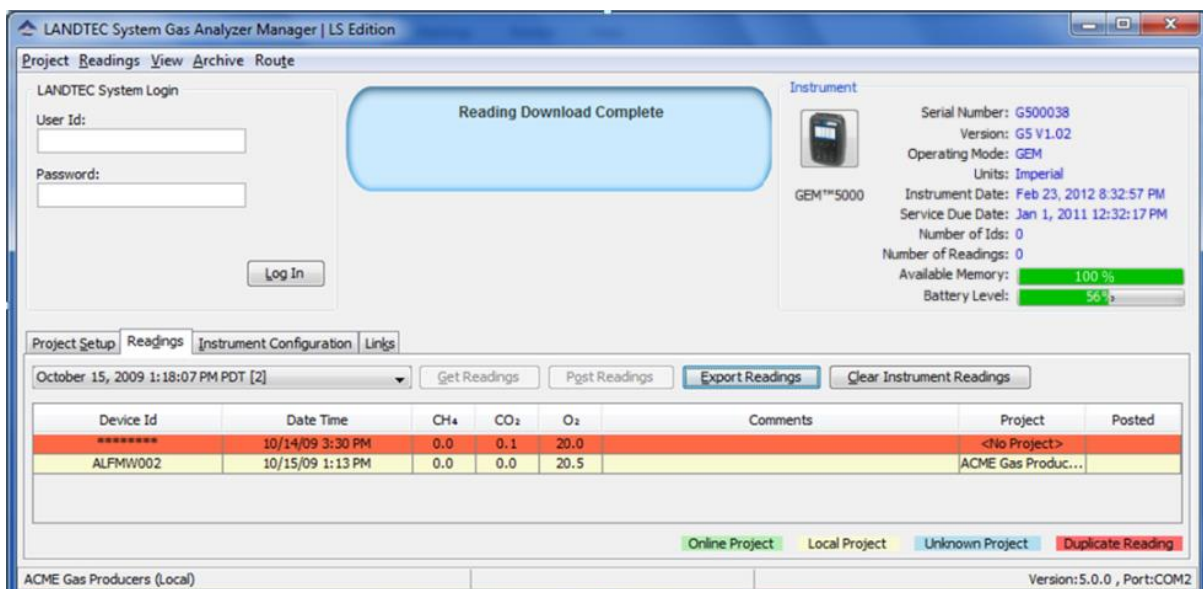
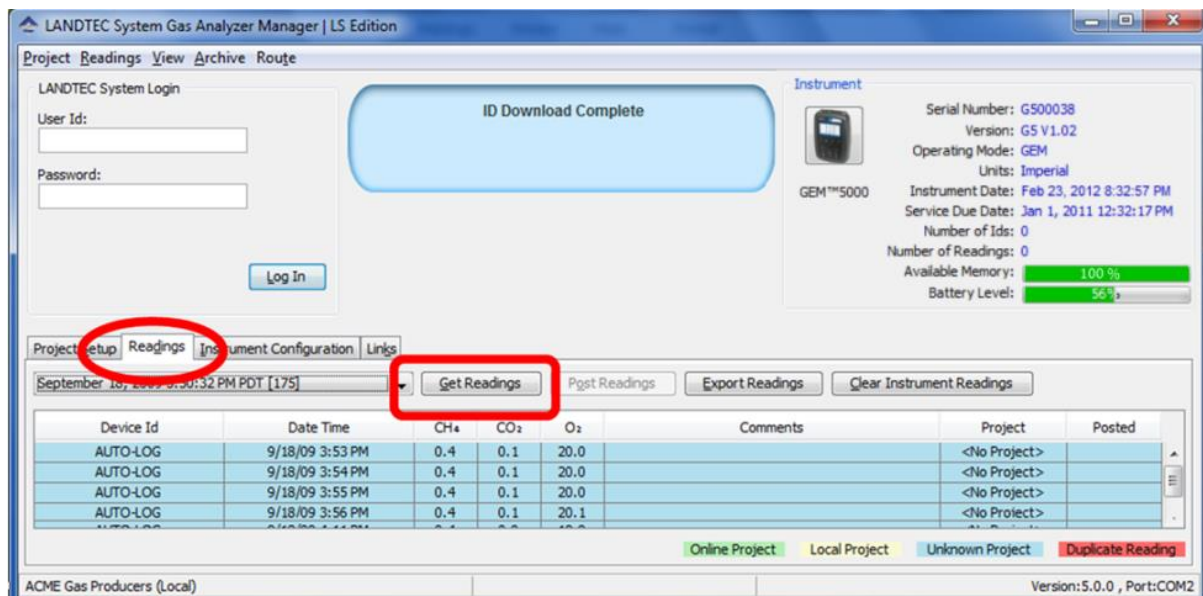

When the instrument is initially detected by the LSGAM software, the Get Readings button will activate if there are readings in the instrument to be downloaded.

Readings will be highlighted based upon the following:

- **Online Project:** If the readings were taken against an ID belonging to an On-Line Enterprise System which the download computer is configured for as (REMOTE) the readings will highlight in a green color.
- **Local Project:** If the readings were taken against a project that is setup on the computer as a local project then they will highlight in a beige color.
- **Unknown Project:** IDs in the instrument that do not match any of the Local or Remote projects on the download computer. This is the result of uploading an instrument with IDs from one computer but downloading on a different computer without the exact same project configuration(s).
- **Duplicate Reading:** This does not imply that the reading was taken twice. Rather it is an indication that the reading was previously downloaded and exists on the computer in a different readings file.

Placing your mouse over a reading will display additional parameters of the reading. As shown below on the left, clicking on a reading will open a Reading details window and allow you to click through the readings one-by-one in detail by clicking the **Previous** and **Next** buttons.

# GEM5000 Gas Analyzer

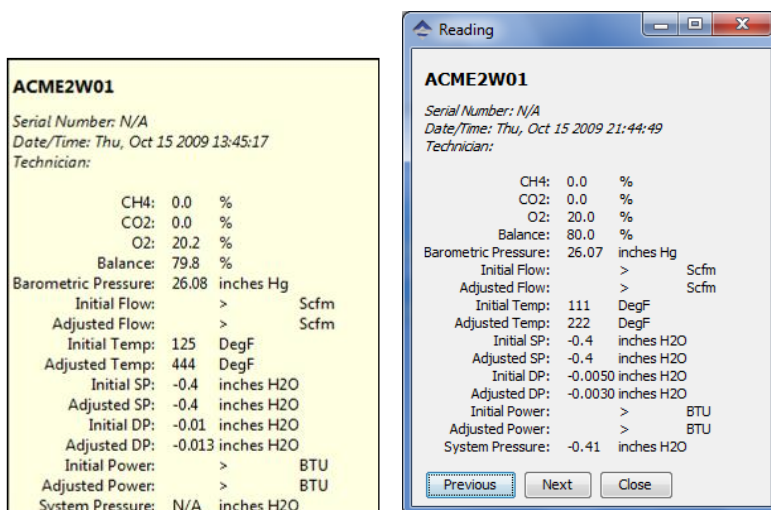

## 10.7.16 Clear Readings

To clear the readings from your instrument, after the readings are downloaded successfully, click the **Clear Instrument Readings** button . A prompt will verify the permanent deletion of the readings from the instrument.

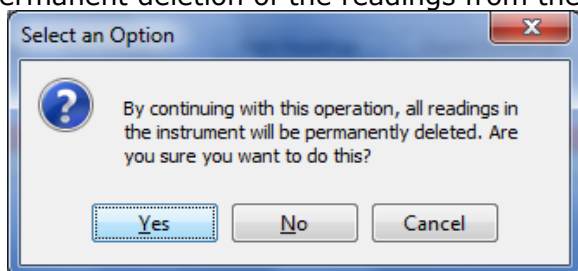

This will clear information within the GEM and GA Mode **simultaneously**.

*Note: Clicking yes will NOT check to ensure all data is saved from the instrument. If you plug in an instrument and click the Clear Instrument Readings button without first performing a Get Readings operation, data not previously downloaded will be lost!*

# GEM5000 Gas Analyzer

## 10.7.17 Exporting Readings

To export readings to a file, click the **Export Readings** button.

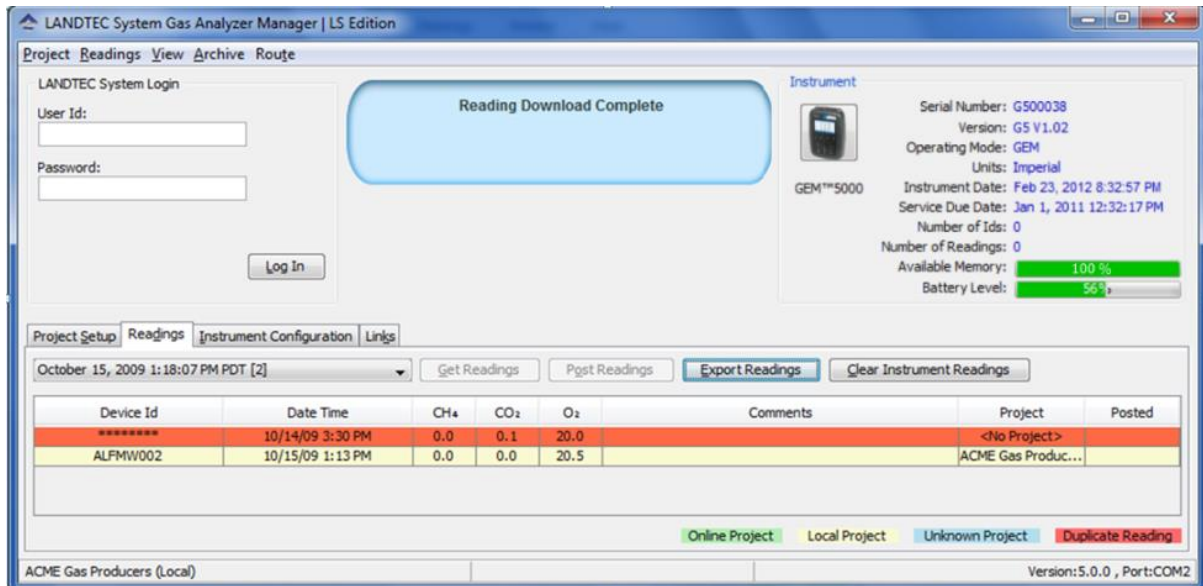

This will open the Stamping Information Screen. Stamping information are details that are most often stored with the historical data but not directly stored by the instrument. Detailed historical Stamping Information can assist when reviewing the data as atmospheric conditions do impact a gas system's production performance.

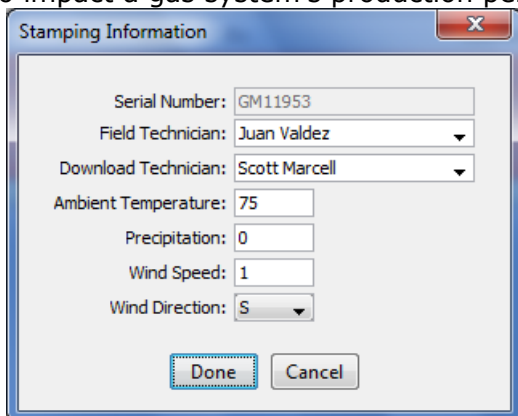

Clicking on Done will open the **Export Readings to CSV** screen.

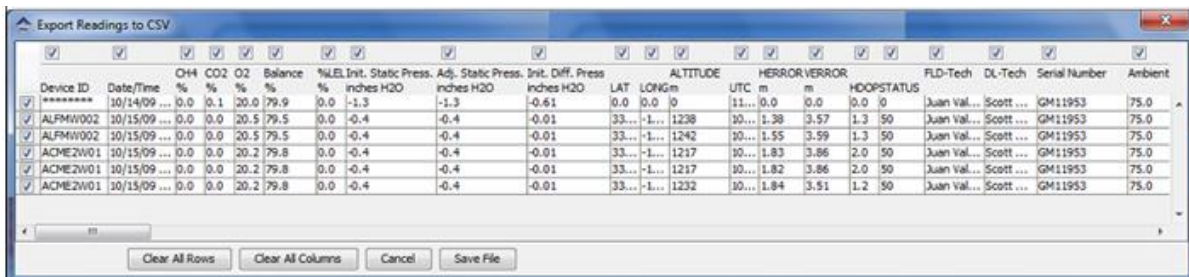

*Note: Depending upon your specific Instrument model you will see additional fields specific to the instrument. For example "NAV" option models have the fields of Latitude, Longitude, Altitude, Herror, Verror, and HDOP Status that the others models do not have.*

# GEM5000 Gas Analyzer

---

This interface provides several options described below.

- To add or remove a single reading from export, uncheck the checkbox in the leftmost column.
- To add or remove a specific parameter from export, uncheck the corresponding checkbox across the top.
- To clear all row checkboxes, click the **Clear All Rows** button at the bottom of the screen. After Clearing all Rows you can click the button and it will change to **Set all Rows**
- To clear all column selections, click on the **Clear All Columns** button at the bottom of the screen. After Clearing All Columns the button will change and you can then choose **Set All Columns**
- To exit the operation without saving, click the **Cancel** button.
- To specify a filename and save the selection to a file, click the **Save File** button. Clicking this button will open a Save window.

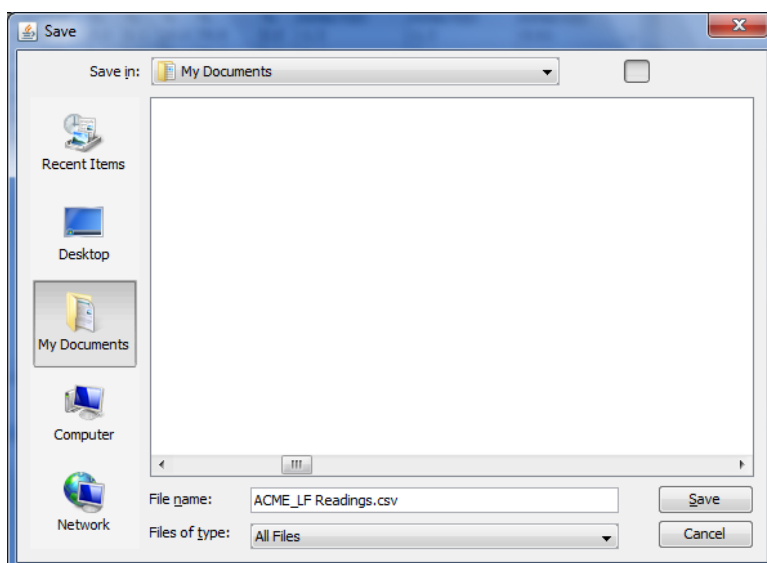

The save file dialog will open and default to the My Documents of the user who is currently logged in on the computer. Specify a filename and location then click the Save button. The selected readings will be saved in comma separated value (.CSV) format. The .CSV file may now be opened in another application such as Microsoft Office Excel or Open Office Calc.

## 11.0 Problem Solving

This section outlines various warning and error messages which the operator may receive during general operation of the instrument. For further assistance please contact Technical Support at (800) 968-2026 or email [landtec\\_support@qedenv.com](mailto:landtec_support@qedenv.com)

## 12.0 Warning and Error display

When switched on, the instrument will perform a pre-determined self-test sequence taking approximately 15 seconds. During this time many of the instrument's working parameters and settings are checked.

If any operational parameters are out of specification or the pre-programmed recommended calibration/service date has passed, errors or warnings may be displayed.

Use the 'Scroll up' and 'Scroll down' keys to move through the list if required.

Only three warnings/errors can be displayed at any time.

To ascertain if more errors have occurred use 'Key 8' - Scroll down' and 'Key 2' - Scroll up' through the list.

# GEM5000 Gas Analyzer

---

## Warnings displayed:

All warnings displayed will be prefixed by the word WARNING followed by a relevant description.

There are two types of warning that may be displayed:

1. General warnings that may not affect the instrument's function and those where the self-test has detected a function that is outside the usual programmed operating criteria, e.g. battery charge low, memory nearly full.
2. Operational parameters that could affect the performance of the analyzer: Cell out of calibration, CH<sub>4</sub> out of calibration, CO<sub>2</sub> out of calibration.

The most likely reason for the errors is either an incorrect user calibration or sensor failure. If an incorrect user calibration has caused the warning it should be correctable by way of returning the instrument to factory settings, zeroing or carrying out a user calibration as necessary for the relevant function.

## 13.0 Service

The GEM5000 gas analyzer should be regularly serviced to ensure correct and accurate operation. QED recommends a service and recalibration every **12 months**.

The GEM5000 range is ATEX certified for use in potentially explosive areas. As such it should be serviced only by qualified engineers. Failure to observe this will result in the warranty becoming invalid and could invalidate the ATEX certification.

 <b>Warning</b>	If the GEM5000 is serviced by unqualified engineers the ATEX certification may be invalidated and the instrument may be unsafe for use in a potentially explosive atmosphere.
--	---

### User serviceable parts:

There are no user serviceable parts inside the instrument.

The following parts can be user serviced:

In-line water filter	This should be regularly inspected for obstructions, moisture or damage and changed if needed. The instrument should never be operated without the in-line water filter as this may result in water entering the instrument.
Sample tubing	Always ensure that sample tubes are not contaminated or damaged.
Gas port connectors	Periodically check that the O-rings on the gas port connectors are not damaged. A damaged O-ring can let air into the sample gas and result in incorrect readings. If the O-ring is damaged the complete gas port connector should be replaced.
H <sub>2</sub> S filter material	When the filter material changes color to a <i>light gray</i> color the filter should be replaced.

## 14.0 Warranty policy

This instrument is guaranteed, to the original end user purchaser, against defect in materials and workmanship for a period of **3 years** from the date of the shipment to the user.

During this period QED will repair or replace defective parts on an exchange basis.

The decision to repair or replace will be determined by QED.

To maintain this warranty, the purchaser must perform maintenance and calibration as prescribed in the operating manual.

Normal wear and tear, and parts damaged by abuse, misuse, negligence or accidents are specifically excluded from the warranty.

 Note: Please contact Technical Support at (800) 968-2026 or email [landtec\\_support@qedenv.com](mailto:landtec_support@qedenv.com) for further information.

## 15.0 Glossary of terms

<b>5000 series</b>	The 5000 series refers to the GA5000, GEM5000 and the Biogas5000 gas analyzers.
<b>Accu-Flo</b>	A flow device used to aid accurate flow measurement.
<b>Analyzer error messages</b>	<p>Operational errors are prefixed on the analyzer by the word ERROR followed by an error code.</p> <p>Refer to the list of standard error codes for more information.</p>
<b>Analyzer warning</b>	<p>Analyzer warnings are prefixed by the word WARNING followed by a relevant description. There are two types of warning messages displayed; general warnings that may not necessarily affect the instrument's function (for example, battery power low) and operational parameters that could affect the performance of the analyser (for example, CH<sub>4</sub> out of calibration).</p>
<b>Anemometer probe</b>	Device for measuring velocity of gas in the pipe. The GEM5000 analyzer can be set to convert into a flow. See also flow measurement.
<b>ATEX certification</b>	The GEM5000 is ATEX certified to zone 1 & 2 areas above ground not in mines.
<b>Auxiliary channel</b>	This refers to the channels where external devices will be connected or displayed.
<b>Backlight</b>	The analyser has a built-in backlight for low ambient light conditions. This can be toggled on/off using the backlight key.
<b>Barometric pressure</b>	The atmospheric pressure at the given location.
<b>Borehole</b>	Typical location from which a gas sample is obtained.
<b>Calibration</b>	The gas analyzer is carefully calibrated against known standards.
<b>Calibration record</b>	The GEM5000 instrument has the facility to log user calibrations as a validation tool.
<b>CH<sub>4</sub></b>	Methane
<b>Chemical cells</b>	A method of gas detection that works on the basis of a chemical reaction with the target gas.
<b>Clean air purge</b>	Process used to clear out gas from the sample tube and analyser prior to taking a new reading.

# GEM5000 Gas Analyzer

---

<b>CO</b>	Carbon monoxide
<b>CO<sub>2</sub></b>	Carbon dioxide
<b>Data logging</b>	Data logging enables the operator to leave the analyzer unattended to take samples at predetermined intervals for a set period of time
<b>Download</b>	Terminology used for the movement of data from the analyzer to the LSGAM application on the PC.
<b>Dual beam infrared absorption</b>	Method of gas detection by measuring how much infrared is absorbed by the target gas.
<b>Event log</b>	<p>Used as an aid to monitoring the use of the analyzer. It can also be used as a diagnostic tool.</p> <p>The event log can be viewed via LSGAM. It <u>cannot</u> be viewed on the analyzer screen.</p>
<b>Exhaust port</b>	The usual manner for the gas to exit the analyzer is via the exhaust port located on the top side of the analyzer. This port should have an exhaust tube attached.
<b>Exhaust tube</b>	Clear plastic tubing used to expel gases from the exhaust port.
<b>Factory settings</b>	Default settings preset at time of manufacture or service.
<b>Firmware</b>	Firmware is the term by which the internal analyzer software is known and is not accessible by the client. This firmware is updated to the latest version when the analyzer is returned for servicing.
<b>Flow measurement</b>	Flow can be measured by either gas velocity m/s or volume flow rate m <sup>3</sup> /hr. This measurement of flow relates to the use of the anemometer and not the internal flow measurement technique.
<b>Flow port</b>	For the measurement of gas flow at the sample point.
<b>Landtec Systems Gas Analyzer Manager</b>	<p>Also referred to as LSGAM. PC based software which enables the operator to upload and download information to/from the analyzer.</p> <p>LSGAM enables operators to maximise the operation of their gas analyzer. It features a simple upload and download facility and is fully compatible with the latest Microsoft™ operating systems.</p> <p>This is optional.</p>



# GEM5000 Gas Analyzer

---

<b>Gas channels</b>	The gases that are analyzed by the instrument.
<b>Gas velocity</b>	The positional rate of change of the gas. Measured using the optional anemometer.
<b>General warnings</b>	Displayed throughout the documentation with a warning symbol. Warning information may affect the safety of operators.
<b>H<sub>2</sub></b>	Hydrogen
<b>H<sub>2</sub>S</b>	Hydrogen sulphide
<b>H<sub>2</sub>S filter</b>	Filter required for removal of H <sub>2</sub> S.  When the filter material changes color to a light gray color or if H <sub>2</sub> S values are displayed, then the filter should be replaced.
<b>Hydro-carbons</b>	Organic compound consisting of only hydrogen and carbon.
<b>In-line water filter</b>	The component used to help protect the instrument from water ingress.
<b>LCD display</b>	Liquid Crystal Display
<b>LEL</b>	Lower Explosive Limit. Lower explosive limit of methane in air. 5% methane in air is the point at which it becomes explosive. 100% LEL equates to 5% methane.
<b>m/s</b>	Meters per second – measurement of gas velocity.
<b>m<sup>3</sup>/hr</b>	Meters cubed per hour – volumetric flow rate measurement.
<b>Main Gas Read Screen</b>	The main analyzer screen for normal operations and all operations are carried out from this screen.
<b>Material data sheet</b>	Document from which information about a certain substance can be obtained.
<b>MCERTS certification</b>	MCERTS is the UK Environment Agency's Monitoring Certification Scheme. The scheme provides a framework within which environmental measurements can be made in accordance with the Agency's quality requirements. The scheme covers a range of monitoring, sampling and inspection activities.
<b>Memory</b>	Location where data and ID information is stored. The analyzer memory should not be used as a permanent storage medium. Stored data should be regularly transferred using the LSGAM download software.

# GEM5000 Gas Analyzer

---

<b>NO<sub>2</sub></b>	Nitrogen dioxide
<b>Operating language</b>	The operator can choose the default operating language for the analyzer. Choices are English, German, Spanish, French and Italian.
<b>PPM</b>	Parts per million
<b>Pump</b>	Used to draw the gas sample from the sample point to the analyzer. Select the pump key  on the analyzer to activate.
<b>ID</b>	The user definable identification tag allocated to a sample point.
<b>Relative pressure</b>	The pressure at the sample point 'relative' to atmospheric (barometric) pressure.
<b>Relative pressure transducer</b>	The internal component used to measure the relative pressure.
<b>Residual N<sub>2</sub></b>	The calculation for the residual N <sub>2</sub> used on the latest version of the GEM5000 platform is as follows:  $\text{Residual N}_2 = \text{Balance} - (\text{O}_2\% \times 3.76)$  Where, Balance = 100% - (CH <sub>4</sub> % + CO <sub>2</sub> % + O <sub>2</sub> %) and 3.76 is the ratio of O <sub>2</sub> to N <sub>2</sub> in ambient air (79/21)
<b>Sample tube</b>	The tube used to obtain a sample of gas from the sample point to the analyzer.
<b>Span</b>	The point at which the gas analyzer is calibrated when a known quantity of the target gas is present.
<b>Span multi gas</b>	Term by which the span calibration of the three main gas channels is known. This option must only be used when the calibration gas being used is a combination of CH <sub>4</sub> CO <sub>2</sub> O <sub>2</sub> .
<b>Technician ID</b>	An alpha-numeric code tagged to each gas reading. Facility only available via LSGAM. This is an optional feature.
<b>Temperature probe</b>	External device used to measure the gas temperature at the sample point. This is optional.
<b>Update site data</b>	Enables the operator to answer pre-defined questions relating to the site, environment etc. These questions are defined via LSGAM software.

# GEM5000 Gas Analyzer

---

<b>Upload</b>	Terminology used for the movement of data from the PC via LSGAM software application to the analyzer.
<b>Volume flow rate</b>	The volume of a gas that passes through a given surface per unit of time e.g. m <sup>3</sup> /hr
<b>Warm-up self-test</b>	Pre-determined self-test sequence to test the analyser functions which takes place after the analyzer is switched on.
<b>Warranty</b>	The instrument is under guarantee against defect in materials and workmanship for a period of 3 years from the date of shipment to the operator and is subject to the recommended service and recalibration requirements.
<b>Water trap</b>	Device used to protect the instrument from water or moisture ingress.
<b>Zero</b>	The point at which the gas analyzer is calibrated when there is none of the target gas present.
<b>Zero transducers</b>	This option allows the relative pressure transducer to be zeroed.



Soil Gas

Vapor Intrusion

Property Redevelopment

Ambient Air Monitoring

Indoor Air Quality

Waste-to-Energy



Air Toxics

## Guide to Air Sampling

Canisters and Bags



[www.AirToxics.com](http://www.AirToxics.com)

Always Air. Always Accurate.

**Eurofins Air Toxics, Inc.**  
**Guide to Whole Air Sampling – Canisters and Bags**

**Revision 6/27/14**

**Contents**

Section 1.0 Introduction .....	1
1.1 Whole Air Sampling of VOCs .....	1
1.2 Choosing Between Canisters and Bags .....	1
Section 2.0 Canisters and Associated Media .....	2
2.1 Introduction to Canisters .....	2
2.2 Associated Canister Hardware .....	3
Section 3.0 Sampling with Canisters.....	5
3.1 Grab Sampling Using Canisters .....	5
3.2 Integrated Sampling with Canisters and Flow Controllers .....	6
3.3 Soil Gas Sample Collection.....	9
Section 4.0 Sampling with Bags .....	14
4.1 Introduction to Bags.....	14
4.2 Air Bag Sampling.....	15
Section 5.0 Special Sampling Considerations .....	17
5.1 Special Sampling Configurations.....	17
5.2 Considerations for Sampling at Altitude .....	18
5.3 Considerations for Soil/Landfill Gas Sampling .....	18
5.4 Considerations for Sample Cylinder Sampling.....	19

## Section 1.0 Introduction

Eurofins Air Toxics Inc. presents this guide as a resource for individuals engaged in air sampling. Air sampling can be more involved than water or soil sampling due to the reactivity of chemical compounds in the gas matrix and sample interaction with the equipment and media used. Ensuring that air samples are collected properly is an important step in acquiring meaningful analytical results. This guide is not a substitute for experience and cannot sufficiently address the multitude of field conditions. Note that this guide is intended for projects involving whole air sampling of volatile organic compounds (VOCs) in canisters and Tedlar® bags. Eurofins Air Toxics provides the “Guide to Sorbent-Based Sampling - Volatiles and Semi-Volatiles” for other types of sampling.

### 1.1 Whole Air Sampling of VOCs

There are three general ways to collect compounds in a gas phase sample. A sampler may collect the gas sample in a container, actively pump the vapor through a sorbent tube, solution or filter, or rely on passive sample collection onto a sorbent bed. This guide focuses on collecting a sample in the most common air sampling containers, Summa canisters and bags. The sample may be collected in the container either passively, relying on an evacuated canister to drive the sample collection, or actively using a pump to fill the container. The container is subsequently sealed and transported to the laboratory for analysis. The sample is referred to as a “whole air sample” and the compounds remain in the gas matrix inside the container.

As a general rule, whole air sampling is appropriate when target compounds are chemically stable and have vapor pressures greater than 0.1 torr at 25°C and 760mm Hg (EPA standard ambient conditions). Performance of a given compound in a whole air sample is dependent upon its chemical properties, the matrix of the sample, and the degree of inertness of the sample container.

### 1.2 Choosing Between Canisters and Bags

Table 1.2 compares the features and performance of Summa canisters and bags. Summa canisters or similarly treated canisters are rugged containers designed to provide superior inertness and extended sample storage times. Evacuated canisters also do not require a sampling pump for sample collection. By contrast, bags require a sample pump, but can be purchased inexpensively in bulk, require little preparation or cleaning, and take up little space prior to use. Unlike canisters, bags are typically not appropriate for ppbv-level VOC measurements due to their background artifacts and short hold-times. Over time, low molecular weight gases can diffuse through the bag material while chemicals with lower vapor pressures can condense on the bag surface thereby compromising analyte recoveries. Call your Project Manager at 800-985-5955 if you have questions regarding the appropriate sampling media.

**Table 1.2 Comparison of Canisters to Bags**

	Canisters	Bags
<b>Type of Sampling</b>	Passive (vacuum)	Active (pump required)
<b>Media Hold Time</b>	Up to 30 days recommended	Indefinite
<b>Hold Time to Analysis</b>	Up to 30 days	Up to 3 days
<b>Surface Inertness</b>	Excellent	Fair
<b>Cleanliness</b>	Batch or 100% certified to ppbv/pptv levels	Some VOCs present in the ppbv range
<b>Sampling Application</b>	Ambient air, soil/landfill gas	Soil/landfill gas, stationary sources, SVE systems
<b>Rule of Thumb</b>	“ppbv device”	“ppmv device”
<b>Advantages</b>	Inertness, hold time, ruggedness, no pump	Purchase/shipping cost, availability, convenience

## Section 2.0 Canisters and Associated Media

*This section provides a description of air sampling canisters, practical considerations for sampling, and step-by-step instructions for collecting grab and integrated samples.*

*Photographs illustrate the correct way to assemble the various sampling components.*

*Tables provide detailed information on many operational factors that ultimately influence the quality of the data obtained from a canister sample.*

### 2.1 Introduction to Canisters

An air sampling canister is a container for collecting a whole air sample. A canister may be spherical or cylindrical and is constructed of specially treated stainless steel. The canister is prepared for sampling by evacuating the contents to a vacuum of approximately 29.9 inches of Mercury (in Hg). Opening the stainless steel bellows valve allows the air sample to enter the canister. Flow controllers can be utilized to restrict the flow and allow for collection at a desired flow rate or over a desired range. When the sample has been collected, the valve is closed and the canister is returned to the laboratory. Canisters range in volume from less than 1 liter (L) to 6 L. In general, 6 L canisters are used to collect ambient air samples and samples requiring time integration greater than 2 hours. One liter canisters are typically used for taking high concentration (i.e., greater than 5 ppbv) samples not requiring time integration such as soil vapor.



#### 2.1.1 Summa Canister

A Summa canister is a stainless steel container that has had the internal surfaces specially passivated using a “Summa” process. This process combines an electropolishing step with a chemical deactivation step to produce a surface that is nearly chemically inert. A Summa surface has the appearance of a mirror: bright, shiny and smooth. The degree of chemical inertness of a whole air sample container is crucial to minimizing reactions with the sample

and maximizing recovery of target compounds from the container. Eurofins Air Toxics maintains a large inventory of Summa canisters in 1 and 6 L volumes.

#### 2.1.2 Canister Certification

Eurofins Air Toxics provides two types of canister cleaning certification, batch and 100%, depending upon the requirements of the project. The batch certification process is most appropriate for routine ambient air applications and high concentration applications such as soil vapor and landfill gas monitoring. The batch certification process begins by cleaning a set of canisters using a combination of dilution, heat and high vacuum. The cleaning batch is certified by analyzing a percentage of canisters for approximately 60 VOCs using GC/MS. The batch meets cleaning requirements if the target compound concentrations are below 0.2 ppbv. Alternatively, the 100% certification (i.e., individual certification) process is typically required for ambient and indoor air applications driven by risk assessment or litigation requiring pptv (parts per trillion by volume) sensitivity. If 100% certification is required, canisters are individually certified for a client-specific list of target compounds using GC/MS. When the 100% certified canisters are shipped, the analytical documentation demonstrating that they are free of the target compounds down to the project reporting limits is emailed to the client. When sampling with certified media, it is important to note that all media is certified as a train and must be sampled as such (i.e., a particular flow controller goes with a particular canister and is labeled as such).



Specify whether your project requires batch or 100% canister certification.

#### 2.1.3 Canister Hold Time

**Media Hold Time:** Unlike water and soil environmental samples, which are collected in single-use, disposable vials and jars, air samples are collected in reusable summa canisters. Eurofins Air Toxics requires that canisters be returned within 15 days of receipt to effectively manage our inventory and to insure canisters meet performance requirements in the field. Evacuated canisters have a finite timeframe before the canisters naturally lose

vacuum during storage. Using canisters beyond 15 days increases the risk of having unacceptable initial vacuum at the start of sampling.

**Sample Hold Time:** EPA Method TO-15 cites a sample hold time of up to 30 days for most VOCs. Several non-routine compounds, such as bis(chloromethyl)ether, degrade quickly and demonstrate low recovery even after 7 days. Reactive sulfur compounds such as hydrogen disulfide and methyl, ethyl, and butyl mercaptan are not amenable to storage in stainless steel summa canister, and either fused silica lined (FSL) canisters or Tedlar bags are required for sample collection.

## 2.2 Associated Canister Hardware

Associated hardware used with the canister includes the valve, brass cap, particulate filter and vacuum gauge. (Flow controllers are covered in detail in section 3.2.)

### 2.2.1 Valve

An industry standard 1/4" stainless steel bellows valve is mounted at the top of the canister. The valve maintains the vacuum in the canister prior to sampling and seals the canister once the sample has been collected. No more than a half turn by hand is required to open the valve. Do not over-tighten the valve after sampling or it may become damaged. A damaged valve can leak, possibly compromising the sample. Some canisters have a metal cage near the top to protect the valve.

To protect the valve and provide secure connections in the field, a replaceable fitting is attached to all canisters. As threads wear and require replacement, new fittings can be installed at the laboratory prior to shipping to the field. You will need a 1/2" wrench to secure the fitting while connecting or removing the required equipment to the canister.

### 2.2.2 Brass Cap

Each canister comes with a brass cap (i.e., Swagelok 1/4" plug) secured to the inlet of the valve assembly. The cap serves two purposes. First, it ensures that there is no loss of vacuum due to a leaky valve or a valve that is accidentally opened during handling. Second, it prevents dust and other particulate matter from damaging the valve. The cap is removed prior to sampling and replaced following sample collection.



Always replace the brass cap following canister sampling.

### 2.2.3 Particulate Filter

Particulate filters should always be used when sampling with a canister. Separate filters are provided to clients taking a grab sample, and filters are built into the flow controllers for clients taking integrated samples. The 2 micron filter is a fritted stainless steel disk that has been pressed into a conventional Swagelok adapter. This device has a relatively high pressure drop across the fritted disk and restricts the flow into the canister even when sampling without a flow controller. Table 2.2.3 lists the typical fill time for a grab sample using a 2 micron particulate filter.



**Table 2.2.3 Grab Sample Fill Times for Canisters**

CANISTER VOLUME	2 micron filter
6 L	<5 minutes
1 L	<1 minute



#### **2.2.4 Fittings**

All fittings on the sampling hardware are 1/4" Swagelok, and a 9/16" wrench is used to assemble the hardware. A 1/2" wrench is also required to tighten fittings onto a union connector. Compression fittings should be used for all connections. Never use tube-in-tube connections. It is critical to avoid leaks in the sampling train. Leaks of ambient air through fittings between pieces of the sampling train will dilute the sample and cause the canister to fill at a faster rate than desired. Eurofins Air Toxics can provide the necessary fittings and ferrules if requested.

#### **2.2.5 Vacuum Gauge**

A vacuum gauge is used to measure the initial vacuum of the canister before sampling, and the final vacuum upon completion. A gauge can also be used to monitor the fill rate of the canister when collecting an integrated sample. Eurofins Air Toxics provides 2 types of gauges. For grab sampling, a test gauge checks initial and final vacuums only and is not to be sampled through. For integrated sampling a gauge is built into the flow controller and may be used for monitoring initial and final vacuums, as well as monitoring the fill rate of the canister. Both gauges are considered to be rough gauges, intended to obtain a relative measure of vacuum change. Accuracy of these field gauges are generally on the order of +/- 5 in Hg. Individuals with work plans that outline specific gauge reading requirements are strongly encouraged to purchase and maintain their own gauges in the field. In special cases, a laboratory-grade, NIST-traceable vacuum gauge can be provided upon request.



The vacuum gauges that are routinely provided are intended as a rough gauge measurement device (+/-5 in Hg accuracy).

## Section 3.0 Sampling with Canisters

There are two basic modes of canister sampling: grab and integrated. A grab sample is taken over a short interval (i.e., 1-5 minutes) to provide a point-in-time sample concentration, while an integrated sample is taken over a specified duration or utilizing a specified flow rate. In both modes the canister vacuum is used to draw the sample into the canister. This is commonly referred to as passive canister sampling. Sections 3.1 and 3.2 detail procedures for grab and integrated sampling, and section 3.3 provides procedures specific to soil vapor collection.

Regardless of the type of canister samples collected, the following rules apply:

- DO NOT use canister to collect explosive substances, radiological or biological agents, corrosives, extremely toxic substances or other hazardous materials. It is illegal to ship such substances and you will be liable for damages.
- ALWAYS use a filter when sampling. NEVER allow liquids (including water) or corrosive vapors to enter canister.
- DO NOT attach labels to the surface of the canister or write on the canister; you will be liable for cleaning charges.
- DO NOT over tighten the valve, and remember to replace the brass cap.
- IF the canister is returned in unsatisfactory condition, you will be liable for damages.
- DO NOT make modifications to the equipment connections and/or use Teflon tape unless approved by the laboratory.
- AND, if you have any questions or need any support, our experienced project management team is just a phone call away at 800-985-5955.



Use a 9/16" and 1/2" wrench to tighten Swagelok connections on the canister sampling train.

### 3.1 Grab Sampling Using Canisters

The most common hardware configuration used to take a grab sample is to simply attach a particulate filter to the canister inlet. A particulate filter is shown in section 2.2.3 and is used to prevent particulate matter from fouling the valve and entering the canister.



#### 3.1.1 Step-By-Step Procedures for Canister Grab Sampling

These procedures are for a typical ambient air sampling application; actual field conditions and procedures may vary.

##### Before you get to the field:

1. Verify contents of the shipped package (e.g., chain-of-custody, canister, particulate filter, and gauge – if requested).
  2. Make sure you include a 9/16" and 1/2" wrench in your field tool kit.
  3. Verify the gauge is working properly.
  4. Verify the initial vacuum of canister as described in the following section:
- **Verify Initial Vacuum of the Canister:** Prior to shipment, each canister is checked for mechanical integrity. However, it is still important to check the vacuum of the canister prior to use. Eurofins Air Toxics recommends doing this before going to the field if possible. The initial vacuum of the canister should be greater than 25 in Hg. If the canister vacuum is less than 25 in Hg, ambient air may have leaked into the canister during storage or transport and the sample may be compromised. Contact your Project Manager if you have any questions on whether to proceed with sample collection. If

sampling at altitude, there are special considerations for gauge readings and sampling (see Section 5.2). The procedure to verify the initial vacuum of a canister is simple but unforgiving.

1. Confirm that valve is closed (knob should already be tightened clockwise).
2. Remove the brass cap.
3. Attach gauge.
4. Attach brass cap to side of gauge tee fitting to ensure a closed train.
5. Open and close valve quickly (a few seconds).
6. Read vacuum on the gauge.
7. Record gauge reading on “Initial Vacuum” column of chain-of-custody.
8. Verify that canister valve is closed and remove gauge.
9. Replace the brass cap.



#### When ready to sample:

1. Confirm that valve is closed (knob should already be tightened clockwise).
2. Remove brass cap.
3. Attach particulate filter to canister.
4. Open valve 1/2 turn (6 L canister normally takes less than 5 minutes to fill).
5. Close valve by hand tightening knob clockwise.
6. Verify and record final vacuum of canister (repeat steps used to verify initial vacuum). For grab samples, the ending vacuum is typically close to ambient pressure (0 in Hg).
7. Replace brass cap.
8. Fill out canister sample tag (make sure the sample ID and date of collection recorded on the sample tag matches what is recorded on the COC exactly).
9. Return canister in box provided.
10. Return sample media in packaging provided.

11. Fill out chain-of-custody and relinquish samples properly (it is important to note the canister serial numbers on the chain-of-custody).
12. Place chain-of-custody in box and retain pink copy.
13. Tape box shut and affix custody seal (if applicable) across flap.
14. Ship accordingly to meet method holding times.



Return all equipment used or unused to the laboratory. Unreturned canisters and associated hardware will result in additional charges as outlined in the media agreement.

### 3.2 Integrated Sampling with Canisters and Flow Controllers

As an alternative to an “instantaneous” grab sample, an air sample collected at a controlled rate is referred to as an integrated sample. Flow controllers or flow restrictors are devices which provide sample collection at a desired flow rate and/or sampling interval. By using a flow controller at a specified flow rate, air samples can provide information on average compound concentrations over a defined period. For example, an 8- or 10-hour integrated sample can be used to determine indoor air quality in the workplace. Similarly, a 24-hour integrated sample may be collected to determine residential exposure to indoor or outdoor air sources. In addition to using a flow controller for time-integrated sample collection, a flow controller may be required for soil gas collection to restrict the vacuum applied to the soil and pore water and to collect a representative sample with minimal intrusion of ambient air.

Eurofins Air Toxics provides two general types of flow controllers: mass flow controllers and critical orifice devices. Both devices are driven by differential pressure between ambient conditions and vacuum in the canister.

### 3.2.1 Mass Flow Controller

A mass flow controller employs a diaphragm that actively compensates to maintain a constant mass flow rate over the desired time period. As the differential pressure decreases, the flow rate decreases and the diaphragm responds by opening up to allow more air to pass through to maintain a stable flow rate. Mass flow controllers are calibrated in the laboratory to provide flow rates suitable for durations up to 24 hours. Durations greater than 24 hours are possible, however, performance of the flow controller is less reliable due to the low flow rates required.



### 3.2.2 Critical Orifice Devices

Eurofins Air Toxics has two types of critical orifice controllers – “capillary column” and “frit pressed”. Both types restrict the flow rate and the canister fill rate decreases as the canister fills to ambient pressure.



These controllers are suitable for applications not requiring constant flow rate over the sampling period such as soil vapor collection or at sites in which temporal variability of VOCs is not expected. Critical orifice devices can cover intervals from 0.5 to 12 hours and flow rate from 10 to 250

ml/min. The “capillary column” device (also known as the Blue Body Flow Controller) restricts air flow by forcing the sample to enter a capillary column of minute radius. The flow rate is a function of the length of inert capillary column. The frit pressed device has a critical orifice machined to meet a set flow rate.



### 3.2.3 Sampling Interval and Flow Controller Setting

When you request canisters and flow controllers from Eurofins Air Toxics, you will be asked for the flow rate (soil vapor) or sampling interval (ambient air), and the flow controllers will be pre-set prior to shipment. The flow rate is set at standard atmospheric conditions (approximately sea level and 25°C). If samples will be collected at elevation or at ambient temperatures significantly different than 25°C, the canister will fill faster or slower depending on sample conditions. If you specify unusual sample conditions at the time of project set-up, we can set the flow controller accordingly. (See Section 5.2 for a discussion of collecting a sample at elevation.) Mass flow controllers should not be utilized for source or process samples in which the collection point is under vacuum or pressure. Please discuss these specific non-standard field conditions with your Project Manager at the time of project set-up.

**Table 3.2.3 Flow Rates for Selected Sampling Intervals (mL/min)**

Sampling Interval (hrs)	4 min.	0.5	1	2	4	8	12	24
6 L Canister	NA	167	83.3	41.7	20.8	11.5	7.6	3.8
1 L Canister	167	26.6	13.3	6.7	-	-	-	-

Note: Target fill volumes for 6 L and 1 L canisters are 5,000 mL and 800 mL, respectively.

### 3.2.4 Final Canister Vacuum and Flow Controller Performance

For time-integrated sample collection using a mass flow controller, the final vacuum of a canister should ideally be approximately 5 in Hg or greater. The flow rate will remain constant as the canister fills and will start to decrease as the canister vacuum approaches

5 in Hg. At this point, the differential pressure between the canister and ambient air is not sufficient to maintain the set flow rate. Because of normal fluctuations in the flow rate due to changes in field temperature and pressure, the final vacuum typically ranges between 3 and 10 in Hg.

- **If the residual canister vacuum is greater than 10 in Hg** (i.e., more vacuum), the actual flow rate is lower than the set point and less sample volume is collected. When the canister is pressurized prior to analysis, the pressurization dilution will be greater than normal. This will result in elevated reporting limits.
- **If the residual canister vacuum is near ambient pressure** for a time-integrated sample, the canister filled faster than calibrated. Once the vacuum decreases below 5 in Hg, the flow rate begins to decrease from its set point. This scenario indicates that the sample is weighted toward the first portion of the sampling interval. The sampler cannot be certain the desired sampling interval was achieved before the canister arrived at ambient conditions. Although the actual sampling interval is uncertain, the canister still contains a sample from the site.

**Table 3.2.4 Relationship between Final Canister Vacuum, Volume Sampled, and Dilution Factor (6 L Canister)**

Final Vacuum (in Hg)	0	2.5	5	7.5	10	12.5	15	17.5	20
Volume Sampled (L)	6	5.5	5.4	5	4	3.5	3	2.5	2
Dilution Factor*	1.34	1.46	1.61	1.79	2.01	2.30	2.68	3.22	4.02

\*Canister pressurized to 5 psig for analysis

$$\text{Final Reporting Limit} = \text{Method Reporting Limit} \times \text{Dilution Factor (Canister Pressurization)} \times \text{Dilution Factor (Sample Analysis)}$$

$$\text{Dilution Factor (Canister Pressurization)} = \frac{\text{Final Pressure}}{\text{Receipt Pressure}} = \frac{14.7 \text{ psig} + \text{Final Pressure (psig)}}{14.7 \text{ psig}} \left[ \frac{1 - \text{Receipt Vacuum (in Hg)}}{29.9 \text{ in Hg}} \right]$$

### 3.2.5 Considerations for Integrated Sampling with Canisters

Collecting an integrated air sample is more involved than collecting a grab sample. Sampling considerations include verifying that the sampling train is properly configured, monitoring the integrated sampling progress, and avoiding contamination.

- **Avoid Leaks in the Sampling Train:** A leak in any one of these connections means that some air will be pulled in through the leak and not through the flow controller. (Follow the leak check step #4 in 3.2.6).
- **Verify Initial Vacuum of Canister:** See Section 3.1.1 for instructions on verifying initial canister vacuum. A separate gauge is not necessary as both the mass flow controllers and critical orifice flow controllers have built-in rough gauges.
- **Monitor Integrated Sampling Progress:** When feasible, it is a good practice to monitor the progress of the integrated sampling during the sampling interval. The volume of air sampled is a linear function of the canister vacuum. For example, when using a 24-hour mass flow controller, at a quarter of the way (6 hours) into a 24-hour sampling interval, the canister should be a quarter filled (1.25 L) and the gauge should read approximately 6 in Hg lower than



the starting vacuum (~22 in Hg). More vacuum indicates that the canister is filling too slowly; less vacuum means the canister is filling too quickly. If the canister is filling too slowly, a valid sample can still be collected (see Section 3.2.4). If the canister is filling too quickly because of a leak or incorrect flow controller setting, corrective action can be taken. Ensuring all connections are tight may eliminate a leak. It is possible to take an intermittent sample; the time interval need not be continuous.

- **Avoid Contamination:** Flow controllers should be cleaned between uses. This is done by returning them to the laboratory.
- **Caution When Sampling in Extreme Temperatures:** Field temperatures can affect the performance of the mass flow controllers. Laboratory studies have shown that flow rates can increase slightly with decreasing temperatures. A flow rate increase of approximately 10% is expected when sampling at field temperatures of 5 to 10°C.

### 3.2.6 Step-by-Step Procedures for Integrated Sampling

These procedures are for a typical ambient air sampling application; actual field conditions and procedures may vary.

#### Before you get to the field:

1. Verify contents of the shipped package (e.g., chain-of-custody, canister, and flow controller)
2. Make sure you include a 9/16" and 1/2" wrench in your field tool kit.
3. Verify the gauge is working properly
4. Verify the initial vacuum of canister (section 3.1.1)

#### When ready to sample:

1. Confirm that valve is closed (knob should already be tightened clockwise).
2. Remove brass cap from canister.

3. Attach flow controller to canister. The flow controller is securely attached if the flow controller body does not rotate.
4. Place the brass cap at the end of the flow controller creating an air tight train, and quickly open and close the canister valve in order to check for leaks. If the needle on the gauge drops, your train is not airtight. In this case, try refitting your connections and/or tightening them until the needle holds steady.
5. Once the sample train is airtight remove the brass cap from the flow controller and open the canister valve a ½ turn.
6. Monitor integrated sampling progress periodically.
7. Verify and record final vacuum of canister (simply read built-in gauge).
8. When sampling is complete, close valve by hand tightening knob clockwise.
9. Detach flow controller and replace brass cap on canister.
10. Fill out canister sample tag (make sure the sample ID and date of collection recorded on the sample tag matches what is recorded on the COC exactly).
11. Return canisters and associated media in boxes provided. **Failure to return all of the provided equipment will result in a replacement charge as outlined in the media agreement.**
12. Fill out chain-of-custody and relinquish samples properly (it is important to note the canister serial numbers on the chain-of-custody).
13. Place chain-of-custody in box and retain pink copy.
14. Tape box shut and affix custody seal at each opening (if applicable).
15. Ship accordingly to meet method holding times.

### 3.3 Soil Gas Sample Collection

Canisters can be used for the collection of soil vapor by attaching the sampling train to the soil gas probe. Typically, a critical orifice flow controller is used to minimize the applied vacuum in order to minimize partitioning of VOCs from the soil or pore water to the soil vapor. Additionally, lower flow rates help to minimize the intrusion of ambient air into the soil vapor probe. In general, time-integration is not required for soil gas samples; however, there may be exceptions to this rule of thumb. For example, some regulatory guidance documents recommend concurrent indoor air and sub-slab soil vapor collection over a

24-hour period. This means that a mass flow controller calibrated for a 24-hour sample would be required for the sub-slab as well as the indoor air sample.

### 3.3.1 Canister to probe connection – Tubing

Collection of a soil gas sample requires the use of tubing to connect the soil gas probe to the sample train. Teflon FEP tubing is recommended based on its low background and its inertness. Alternative tubing can be used if shown to meet data quality objectives. Please note that Low Density Polyethylene or flexible Tygon tubing is not recommended due to VOC adsorption during sample collection. Teflon tubing is provided by the laboratory upon request at the time of order. A charge based on the length will be assessed. It is important to store the tubing away from VOC sources during storage and transport to the site to minimize contamination.

### 3.3.2 Canister to probe connection –Fittings

To connect the tubing to the canister sampling train, a Swagelok fitting and a pink ferrule are used. The position of the ferrule is key to ensure the fitting is securely connected to the canister. See the figure below for the correct positioning and connection. The pink ferrule is flexible and cannot be over-tightened.



### 3.3.3 Leak Check Compounds Considerations

To determine whether ambient air is introduced into soil gas sample, a leak check may be used. Leak check compounds may be liquid or gaseous tracers. Liquid compounds are challenging to use effectively in the field and can be introduced into the sample due to improper handling in the field, erroneously indicating a leak in the sampling train. Liquid tracers such as isopropanol should never be directly applied to connections in the sampling train. Rather, the liquid is carefully applied to a cloth and placed near the connection or on the ground next to the probe. Great care must be used in the field to insure the liquid tracer is not handled during sampling train assembly or disassembly. Even a trace amount of a liquid tracer on a glove used to replace a canister brass cap can contaminate the sample. Liquid leak check compounds can interfere with the analytical runs, and even small leaks may result in analytical dilution and raised reporting limits when measuring ppbv target compound levels.

Gaseous tracers such as helium are typically used with shroud placed over the sampling equipment and/or borehole. To quantify the leak, the concentration of the tracer gas in the shroud should be measured.



Specify the leak check compound planned for your soil gas sampling event and record on the COC.

### 3.3.4 Step-by-Step Procedures for Soil Vapor Sampling

These procedures are for a typical soil vapor sampling application; actual field conditions and procedures may vary. Please consult your specific regulatory guidance for details.

**Before you get to the field:**

1. Verify contents of the shipped package (e.g., chain-of-custody, canister, tubing, fittings, and flow controller).
2. Make sure you include a 9/16" and 1/2" wrench in your field tool kit.
3. Verify the gauge is working properly.
4. Verify the initial vacuum of canister.

**Prior to vapor collection:**

- **Purge tubing adequately.** A long length of tubing has significant volume of "dead air" inside. Without purging, this air will enter the canister and dilute the sample. Consider using a handheld PID/FID to confirm that you have purged the tubing and are drawing sample air through the tubing. A standard rule of thumb is to utilize 3 purge volumes prior to sample collection. However, under certain circumstances, purge volumes of 1 to 10 may be appropriate. Please review your regulatory guidance and your site specific conditions in determining the appropriate purge volumes.
- **Don't sample water.** If moisture is visible in the sample tubing, the soil gas sample may be compromised. Soil gas probes should be at an appropriate depth to avoid reaching the water table. Additionally, subsurface vapor should not be collected immediately after measurable precipitation.

**When ready to sample:**

1. Confirm that valve is closed (knob should already be tightened clockwise).
2. Remove brass cap from canister.
3. Attach flow controller to canister if needed. The flow controller is securely attached if the flow controller body does not rotate. (Note: The frit-press flow controller and 1 L canister may be pre-assembled by the laboratory.)
4. Place the brass cap at the end of the flow controller creating an air tight train, and quickly open and close the canister valve in order to check for leaks. If the needle on the

gauge drops, your train is not airtight. In this case, try refitting your connections and/or tightening them until the needle holds steady.

5. Once the sample train is airtight remove the brass cap from the flow controller and attach the probe tubing to the flow controller using the pink ferrule and Swagelok nut. (See 3.3.2 for proper positioning of the ferrule.)
6. Once the probe line has been purged and appropriate leak check measures have been implemented, open the canister valve a ½ turn.
7. Verify and record final vacuum of canister (simply read built-in gauge).
8. When canister fills to the desired end vacuum, close valve by hand tightening knob clockwise.

*Please note: Some projects require residual vacuum of approximately 5 in Hg at the end of sample collection even if time-integrated samples are not required. The residual vacuum serves to provide a check of the integrity of the canister during transport to the laboratory to insure no leaks occurred during shipment. A field vacuum reading similar to the lab receipt vacuum reading demonstrated that no leak occurred.*

9. Detach tubing and flow controller and replace brass cap on the canister.
10. Fill out canister sample tag (make sure the sample ID and date of collection recorded on the sample tag matches what is recorded on the COC exactly).
11. Return canisters and associated media in boxes provided. **Failure to return all of the provided equipment will result in a replacement charge as outlined in the media agreement.**
12. Fill out chain-of-custody and relinquish samples properly (it is important to note the canister serial numbers on the chain-of-custody).
13. Place chain-of-custody in box and retain pink copy
14. Tape box shut and affix custody seal at each opening (if applicable)
15. Ship accordingly to meet method holding times



### 3.4.4 Collecting Soil Gas Samples with Sampling Manifolds

If required, Eurofins Air Toxics can provide a sampling manifold to assist with leak checking the sampling train, purging the sampling line, and monitoring the vacuum applied to the soil gas bore hole during sample collection. The manifold is shown below:

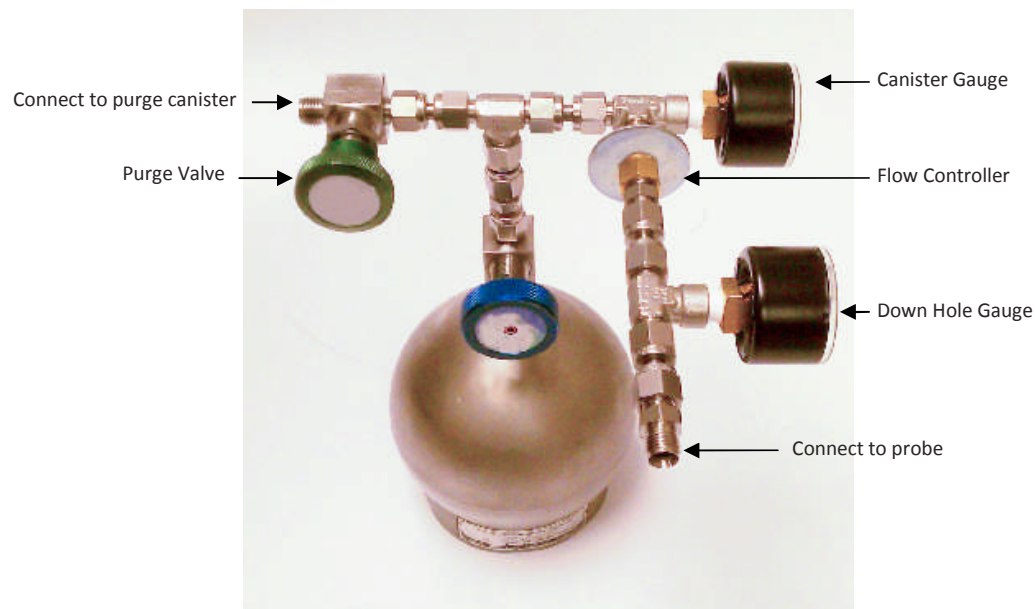

The ‘Down Hole Gauge’, located prior to the flow restrictor, is a vacuum gauge that monitors the vacuum applied to the soil gas probe. Because this is not a flow meter but a measure of pressure/vacuum, the gauge should read at zero if there is sufficient flow from the soil. If the gauge begins to read a vacuum, then the flow is being restricted. Low flow, high vacuum conditions can be encountered when sampling in low permeability soil. The ‘Canister Gauge’, in line after the flow controller and prior to the purge canister, is a vacuum gauge that indicates to the sampler whether or not the canister is filling properly at the expected rate. This setup enables the sampler to evaluate the lithologic conditions at the site and determine if a valid soil gas sample is being taken. Finally, when duplicate

samples are required, the manifold can be used as a duplicate sampling “T” by simply replacing the purge canister with another sample canister.

There are several options to use as a purge vacuum source to attach to the purge valve connection – a Summa canister, sampling pump or sampling syringe. The below instructions assume a Summa canister will be used as a purge volume source since other sources are generally provided by the client.

#### When ready to sample:

##### Leak Check Test

1. Confirm that canister valves are closed (knob should already be tightened clockwise).
2. Remove brass caps from both the sample canister and the purge canister. (Unless using certified media, there is no difference between the two).
3. Attach manifold center fitting to sample canister.
4. Attach purge canister to the Purge Valve end of the manifold by attaching provided Teflon tubing and compression fittings.
5. Confirm that there is a brass cap secured at the inlet of the manifold creating an air tight train, make sure the manifold valve above the purge canister is open, and quickly open and close the purge canister valve in order to check for leaks. If the needle on the gauge drops, your train is not airtight. In this case, try refitting your connections and/or tightening them until the needle holds steady.

##### Purging

6. Once the sample train is airtight remove the brass cap from the manifold inlet, connect the tubing from the sample port using a compression fitting and open the purge canister valve, 1/2 turn.
7. Monitor integrated sampling progress periodically. \*Please note, because the purge canister is inline after the flow restrictor the line will not purge faster than at a rate of 167 ml/min.

8. Once the desired purge volume is met close both the manifold valve and the purge canister valve by hand tightening the knobs clockwise.
9. If sampling at multiple locations, the purge canister can be disconnected from the manifold and used to begin purging the next sample location without compromising the sample train.

### ***Sampling***

10. The line is now ready to be sampled. Open the sample canister valve and monitor sampling progress periodically.
11. When the sampling is complete close the valve and replace the brass cap on the canister; record final vacuum of canister (simply read built-in gauge).
12. Fill out canister sample tag (make sure the sample ID and date of collection recorded on the sample tag matches what is recorded on the COC exactly).
13. Return canisters in boxes provided and all parts of the soil gas manifold. **Unreturned media will result in a replacement charged assessed as described in the media agreement.**
14. Fill out chain-of-custody and relinquish samples properly (it is important to note the canister serial numbers on the chain-of-custody).
15. Place chain-of-custody in box and retain pink copy.
16. Ship accordingly to meet method holding times.

## Section 4.0 Sampling with Bags

*This section provides a description of the types of air sampling bags, selecting the right bag for your application, practical considerations for sampling, and step-by-step instructions for collecting a grab sample. Photographs illustrate the correct way to assemble the various sampling components.*

### 4.1 Introduction to Bags

Air sampling bags are containers used to collect whole air samples for landfill gas, soil gas and stationary source applications. Bags can be constructed from various materials which can differ in terms of stability characteristics and cleanliness. In general, air sampling bags are best suited for projects involving analysis of compounds in the ppmv range. They can be used to collect sulfur compounds, but only if the fittings are non-metallic (e.g., polypropylene, Teflon®, or Nylon).

Air sampling bags are equipped with a valve that allows for filling. Sample collection requires a pressurized sampling port, a low flow rate pump or a lung sampler. The bag expands as the vapor sample is pulled in. When the target volume of the sample is collected, the valve is closed and the bag is returned to the laboratory. Bag materials should be selected based on the specific application. Common air sampling bags include Tedlar film and FlexFoil. Eurofins Air Toxics maintains a limited inventory of air sampling bags in 1 L, 3 L and 5 L volumes.

#### 4.1.1 Tedlar® Film

Tedlar® is a trade name for a polyvinyl fluoride film developed by DuPont Corporation in the 1960's. This patented fluoropolymer has been used in a wide variety of applications including protective surfacing for signs, exterior wall panels and aircraft interiors. Tedlar® film is tough yet flexible and retains its impressive mechanical properties over a wide range

of temperatures (from well below freezing to over 200°F). Tedlar® exhibits low permeability to gases, good chemical inertness, good weathering resistance and low off-gassing.

Tedlar® bags may be used to collect samples containing common solvents, hydrocarbons, chlorinated solvents, sulfur compounds, atmospheric and biogenic gases and many other classes of compounds. Compounds with low vapor pressures such as Naphthalene are not appropriate for Tedlar bags as recovery is very low even under short sample storage times. Low molecular compounds such as Helium and Hydrogen can diffuse through the Tedlar bag material resulting in poor storage stability.



#### 4.1.2 Tedlar® Bag Suppliers and Re-use

Compounds commonly detected from analyzing new Tedlar® bags include methylene chloride, toluene, acetone, ethanol, 2-propanol, phenol, and dimethylacetamide. While levels of these common artifacts are typically in the ppbv range, the cleanliness of bags can vary significantly between vendors, and purchasing bags directly from an unknown vendor should be avoided. Once the Tedlar® bag is used for sample collection, the surface has been exposed to moisture and possible VOCs. It may irreversibly adsorb many VOCs at the low ppbv level. A series of purges with certified gas may not remove the VOCs from the surface. Consider your data quality objectives to determine whether re-using Tedlar® bags is appropriate.

#### 4.1.3 Hold Time for a Tedlar® Bag

The media hold time for a Tedlar® bag is indefinite if stored out of sunlight in a cool, dry location.

The sample hold time to analysis varies by method and compound. See Table 4.1.3 for recommended sample storage times for commonly requested parameters.

**Table 4.1.3 Recommended Maximum Sample Storage Times for Tedlar® Bags**

Analytical Method	Chemical Class	Storage Time
ASTM D5504	Suite of sulfur compounds including Reactive Sulfur compounds (Hydrogen sulfide, Methyl mercaptan)	24 hours
ASTM D1946 ASTM D1945	Atmospheric and natural gases: CO, CO <sub>2</sub> , CH <sub>4</sub> , C <sub>2</sub> -C <sub>5</sub> hydrocarbons (He and H <sub>2</sub> not recommended)	Up to 3 days
Modified TO-14A, TO-15, TO-3, TO-12	Volatile Organic Compounds (VOCs)	Up to 3 days

#### 4.1.4 FlexFoil Bags

FlexFoil bags are made from an opaque and flexible material with 4-ply construction resulting in high physical strength to minimize rupture and leakage and low permeability to provide good stability for low molecular weight compounds. FlexFoil bags are ideal for target compounds such as Hydrogen and Helium and can be used for the suite of atmospheric and natural gas components. While the reactive sulfur compounds, Hydrogen Sulfide and Methyl Mercaptan, show good stability over 24 hours in FlexFoil bags, other sulfur compounds demonstrate low recovery. Table 4.1.4 summarizes the compounds and the hold times amenable to FlexFoil bags.

**Table 4.1.4 Recommended Maximum Sample Storage Times for FlexFoil Bags**

Analytical Method	Chemical Class	Storage Time
ASTM D5504	Hydrogen sulfide, Methyl mercaptan only Not recommended for full sulfur list.	24 hours
ASTM D1946 ASTM D1945	Atmospheric and natural gases Full List	Up to 3 days

#### 4.2 Air Bag Sampling

Using a bag to collect an air sample normally involves “active” sampling, unlike an evacuated canister that can be filled “passively” by simply opening the valve. There are two methods commonly used to fill a bag: a pump or a lung sampler.

- Sampling with a Pump:** The most common method for filling a bag is to use a small pump with low flow rates (50-200 mL/min) and tubing to fill the bag. Eurofins Air Toxics, Inc. does not provide pumps but pumps may be rented from equipment providers or purchased from manufacturers such as SKC or Gilian.
- Sampling with a Lung Sampler:** A “lung sampler” may be used to fill a bag. Although a little more complicated than simply using a pump, the main advantage to using a lung sampler to fill a bag is that it avoids potential pump contamination.



A bag with attached tubing is placed in a small airtight chamber (even a 5-gallon bucket can work) with the tubing protruding from the chamber. The sealed chamber is then evacuated via a pump, causing the bag to expand and draw the sample into the bag through the protruding tube. The sample air never touches the wetted surfaces of the pump. Eurofins Air Toxics does not provide lung samplers, but they can be rented from equipment suppliers or purchased by manufacturers such as SKC Inc.

#### 4.2.1 Considerations for Bag Sampling

Some considerations for collecting a bag sample:

- **Fill the bag no more than 2/3 full:** Allow for possible expansion due to an increase in temperature or decrease in atmospheric pressure (e.g., the cargo hold of a plane)
- **Keep the Tedlar® bag out of sunlight:** Tedlar® film is transparent to ultraviolet light (although opaque versions are available) and the sample should be kept out of sunlight to avoid any photochemical reactions
- **Protect the bag:** Store and ship the bag samples in a protective box at room temperature. An ice chest may be used, but DO NOT CHILL
- **Fill out the bag label:** It is much easier to write the sample information on the label before the bag is inflated. Make sure to use a ball-point pen, never a Sharpee or other marker which can emit VOCs.
- **Provide a “back-up” bag:** Consider filling two bags per location in the rare occasion that a defective bag deflates before analysis. The “hold” sample does not need to be documented on the Chain-of-Custody and should have an identical sample ID to the original sample indicating that it is the “hold” sample
- **Avoid Contamination:** Care should be taken to avoid contamination introduced by the pump or tubing. Begin sampling at locations with the lowest compound concentrations (e.g., sample the SVE effluent before the influent). Decontaminate the pump between uses by purging with certified air for an extended period; better yet, use a lung sampler. Use the shortest length possible of Teflon® tubing or other inert tubing. DO NOT REUSE TUBING. If long lengths of tubing are used, consider purging the tubing with several

volumes worth before sampling. If you are concerned about sampling for trace compounds, you shouldn't be using a Tedlar® bag (see Section 1.2)

- **Don't Sample Dangerous Compounds in a Bag:** Do not ship any explosive substances, radiological or biological agents, corrosives or extremely hazardous materials to Eurofins Air Toxics. Bag rupture during transit to the laboratory is possible and the sampler assumes full liability.

#### 4.2.2 Step-by-Step Procedures for Bag Sampling (Pump)

Note: These procedures are for a typical stationary source (e.g., SVE system) sampling application; actual field conditions and procedures may vary.

##### Before you get to the field:

1. Verify contents of the shipped package (e.g., chain-of-custody, bag, and tubing/fittings – if requested).
2. Verify pump cleanliness and operation (Eurofins Air Toxics does not provide pumps).

##### When ready to sample:

3. Purge sample port.
4. Attach new Teflon® tubing from sample port or probe to low flow rate pump.
5. Purge tubing.
6. Fill out bag sample tag.
7. Attach additional new Teflon® tubing from the pump outlet to the bag valve.
8. Open bag valve.
9. Collect sample (FILL NO MORE THAN 2/3 FULL).
10. Close bag valve by hand tightening valve clockwise.
11. Return filled bags in a rigid shipping container (DO NOT CHILL).
12. Fill out chain-of-custody and relinquish samples properly.
13. Place chain-of-custody in box and retain pink copy.

14. Tape box shut and affix custody seal (if applicable) across flap.
15. Ship first overnight or priority overnight to meet method holding times.



Expedite delivery of air sampling bags to the laboratory for analysis.

## Section 5.0 Special Sampling Considerations

*This section provides recommendations for the collection of field QC samples such as field duplicates. Considerations for sampling at altitude, sampling SVE ports and using sample cylinders are presented.*

### 5.1 Field QC

To measure accuracy and precision of the field activities, project plans often include field duplicates, field blanks, ambient blanks, trip blanks and/or equipment blanks.

#### 5.1.1 Field Duplicate

A field duplicate is a second sample collected in the field simultaneously with the primary sample at one sampling location. The results of the duplicate sample may be compared (e.g., calculate relative percent difference) with the primary sample to provide information on consistency and reproducibility of field sampling procedures. Due to the nature of the gas phase, duplicate samples should be collected from a common inlet. The configuration for collecting a field duplicate includes stainless steel or Teflon® tubing connected to a Swagelok “T”. If integrated samples are being collected and the sample duration is to be maintained, the sample train should be assembled as follows: each canister should have a flow controller attached, then the duplicate sampling T should be attached to the flow controllers. If the collection flow rate from the sample port is to be maintained then the

duplicate sampling T should be connected to the canisters; then the flow controller is connected to the inlet of the sampling T.

Alternatively, if the project objective is to assess spatial or temporal variability, then field duplicates may be deployed in close proximity (ambient air sampling) or samples may be collected in succession (soil vapor).

#### 5.1.2 Field Blank

A field blank is a sample collected in the field from a certified air source. Analysis of the field blank can provide information on the decontamination procedures used in the field. Clean stainless steel or Teflon® tubing and a certified regulator should be used. It is imperative that individually certified canisters (the sample canister and the source canister/cylinder, if applicable) be used to collect a field blank.

#### 5.1.3 Ambient Blank

An ambient blank is an ambient air sample collected in the field. It is usually used in conjunction with soil gas or stationary source (e.g., SVE system) sampling. Analysis of the ambient blank can provide information on the ambient levels of site contaminants. It is recommended that an individually certified canister be used to collect an ambient blank.

#### 5.1.4 Trip Blank

When sampling for contaminants in water, the laboratory prepares a trip blank by filling a VOA vial with clean, de-ionized water. The trip blank is sent to the field in a cooler with new sample vials. After sampling, the filled sample vials are placed back in the cooler next to the trip blank and returned to the laboratory. Analysis of the trip blank provides information on decontamination and sample handling procedures in the field as well as the cleanliness of the cooler and packaging.

When sampling for compounds in air, a trip blank provides little, if any, of the information above. A trip blank canister can be individually certified, evacuated, and sent to the field in a box with the sample canisters. Since the valve is closed and the brass cap tightened, it is questionable if the trip blank canister contents are ever “exposed” to sampling conditions. The trip blank VOC concentrations essentially provide information regarding the cleanliness and performance of the trip blank canister. Results cannot necessarily be applied to the associated field sample canisters accompanying the trip blank. **Eurofins Air Toxics does not recommend collecting a trip blank for air sampling.**

## 5.2 Considerations for Sampling at Altitude

Sampling at altitudes significantly above sea level is similar to sampling a stationary source under vacuum in that target fill volumes may be difficult to achieve. The figure to the right illustrates the relationship between increasing altitude and decreasing atmospheric pressure. Ambient conditions in Denver at 5,000 ft altitude are quite different from ambient conditions at sea level. Canister sampling is driven by the differential pressure between ambient conditions and the vacuum in the canister.

There is less atmospheric pressure in Denver and 5 L is the maximum fill volume of standard air assuming the canister is allowed to reach ambient conditions (i.e., final gauge reading of 0 in Hg). Theoretically, if you sample high enough (e.g., in space), no sample would enter the canister because there is no pressure difference between the evacuated canister and ambient conditions. To fill a canister to 6 L in Denver, you would need to use an air pump.

Sampling at altitude also affects gauge readings. The gauges supplied by Eurofins Air Toxics, Inc. (see Section 2.2.4) measure canister vacuum relative to atmospheric pressure and are calibrated at approximately sea level. Before sampling at altitude, the gauges should be equilibrated (see Section 3.1). But even after equilibrating the gauge, verifying the initial vacuum of a canister at altitude is misleading. In Denver at 5,000 ft, expect the gauge to read 25, not 29.9 in Hg. You do not have a bad canister (i.e., leaking or not evacuated properly). The canister is ready for sampling and the gauge is working properly.



**Rule of Thumb:** For every 1,000 ft of elevation, the gauge will be off by 1 in Hg and the fill volume will be reduced by 1/5 L.

If you have questions about sampling at altitude, please call your Project Manager at 800-985-5955.

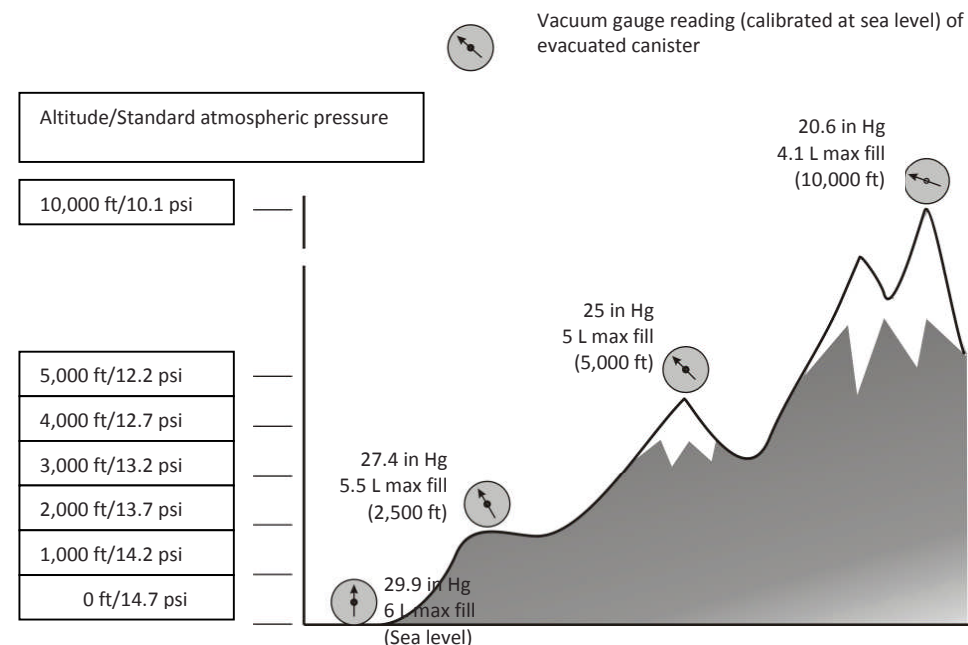

## 5.3 Considerations for SVE/LFG Collection System Sampling

There are some additional sampling considerations for collecting grab samples (canister or bag) from a Soil Vapor Extraction (SVE) system or landfill gas (LFG) collection system. The general challenge with these samples arises from the need to employ a length of tubing to direct the landfill gas or process air to the canister or bag. Tubing introduces the potential for contamination and diluting the sample.

- **Use inert tubing.** Teflon® tubing is recommended. Tubing with an outer diameter of ¼” works best with the fittings on the particulate filter. (See Section 3.3.1).
- **Do not reuse tubing.**
- **Purge tubing adequately.** A long length of tubing has significant volume of “dead air” inside. Without purging, this air will enter the canister and dilute the sample. Consider using a handheld PID/FID to confirm that you have purged the tubing and are drawing sample air through the tubing.
- **Avoid leaks in the sampling train.** Leaks of ambient air through fittings between pieces of the sampling train (e.g., tubing to particulate filter) will dilute the sample.
- Always use compression fittings for all connections; never use tube in tube connections.
- **Purge the sample port.** A sample port on an SVE system or LFG collection system can accumulate solids or liquids depending upon the location of the port in the process and the orientation of the port. An influent sample port located upstream of a filter or moisture knock-out can be laden with particulates or saturated with water vapor. Heavy particulate matter can clog the particulate filter and foul the canister valve. It is important to prevent liquids from entering the canister. A sample port oriented downward may have liquid standing in the valve. Purge the sample port adequately before connecting the sampling train.
- **Consider the effects of sampling a process under vacuum or pressure.** When collecting a grab sample from a stationary source such as an SVE system or LFG collection system, some sample ports may be under vacuum or pressure relative to ambient conditions. When the sample port is under vacuum, such as the header pipe from the extraction well network, it may be difficult to fill the canister with the desired volume of sample. A vacuum pump may be used to collect a canister grab sample from a sample port under considerable vacuum. See the related discussion on sampling at altitude in Section 5.2. When the sample port is under pressure, such as the effluent stack downstream of the blower and treatment system, you may inadvertently pressurize the canister. Only a DOT-approved sample cylinder should be used to transport pressurized air samples (see Section 5.4). Under no circumstances should a Summa canister be pressurized more than 15 psig. Bleed off excess pressure by opening the valve temporarily while monitoring the canister with a pressure gauge.

## 5.4 Considerations for Sample Cylinder Sampling

Sample cylinders, also known as “sample bombs”, are DOT-approved, high pressure, thick-walled, stainless steel cylinders with a valve at each end. They were intended for collecting a pressurized sample for petroleum gas applications. Sample cylinders differ from sample canisters in that they do not have a Summa-passivated interior surface and are not evacuated prior to shipment. Sample cylinders are not suitable for analysis of hydrocarbons at ppbv levels. Sample cylinders can be used for analysis of natural gas by ASTM D-1945 and calculation of BTU by ASTM D-3588. Eurofins Air Toxics assumes that clients requesting a sample cylinder have a pressurized process and sample port with a built-in gauge and 1/4” Swagelok fitting to attach to the sample cylinder. Eurofins Air Toxics has a limited inventory of 500 mL sample cylinders that are particularly suited for landfill gas collection systems (i.e., LFG to energy applications). This section provides step-by-step procedures for sampling with a sample cylinder.



Inform the lab during project set up if hazardous samples (e.g. high Hydrogen Sulfide concentrations) will be collected to verify the lab can safely handle the samples.

### Step-by-Step Procedures for Sample Cylinder Sampling

These procedures are for a typical stationary source sampling application and actual field conditions; procedures may vary. Follow all precautions in the site Health and Safety Plan when dealing with a pressurized sample port and sample cylinder. Follow required DOT guidelines for packaging and shipping.

1. Verify contents of the shipped package (e.g., chain-of-custody, sample cylinder, particulate filter).
2. Verify that gauge on sample port is working properly.
3. Purge sample port.



4. Remove brass caps on either end of cylinder.
5. Attach particulate filter to upstream valve.
6. Attach filter/cylinder assembly directly to the sample port.
7. Open both valves 1/2 turn.
8. Allow sample air to flow through sample cylinder (approximately 10 L for a 500 mL cylinder).
9. Close downstream valve of sample cylinder by hand tightening knob clockwise.
10. Allow sample cylinder to pressurize to process pressure (max 100 psig).
11. Close upstream valve of sample cylinder and sample port.
12. Detach filter/cylinder assembly from sample port and remove particulate filter.
13. Replace brass caps.
14. Fill out sample cylinder sample tag.
15. Fill out chain-of-custody and relinquish samples properly.
16. Include the chain-of-custody with the samples and retain pink copy.
17. Pack, label, and ship according to DOT regulations.



Follow DOT regulations for packaging and shipping hazardous samples.



**Eurofins Air Toxics, Inc.**

180 Blue Ravine Road, Suite B | Folsom, CA 95630

Tel | 1-800-985-5955 | Fax | 916-985-1020

[www.AirToxics.com](http://www.AirToxics.com)



## Field Sampling Procedure Using Summa Canisters with RAVEqc Quick-Connect (QT) Fittings

### Grab Sample Setup (without flow controller)

- 1) You should have received a female QT vacuum gauge assembly and filter with your canister.
- 2) Place canister in desired location that you wish to sample.
- 3) Pull back on the sleeve of the female QT fitting located on the filter/gauge pair.



- 4) Place the female end of the QT valve over the male QT valve located on the top of the canister then release the sleeve once fully seated. Gently pull up on the filter/gauge pair to make sure they are fully connected to the canister.

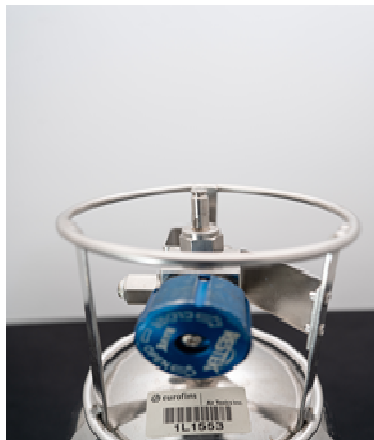

- 5) Verify initial vacuum of the canister. The initial vacuum should be **greater than 25 "Hg**.
  - a. Confirm that valve is closed (knob should already be tightened clockwise)

- b. Attach vacuum gauge or flow controller (brass cap will be installed on Swagelok end)
- c. Open and close valve quickly.
- d. Record initial vacuum level ("Hg) on the COC.
- e. If a shut-in test is required, monitor the vacuum reading per project requirements prior to removal of brass cap

**Note:** Gauges fitted with Quick Connect fittings will hold residual vacuum after disconnecting from the canister. If you are using the same vacuum gauge to check vacuum levels of multiple canisters, you may want to release this vacuum between readings. Using a 9/16" wrench, loosen the brass nut located on the gauge. This will return the gauge to zero. Retighten the brass cap and the gauge will be ready for the next vacuum check.

- 6) To begin sampling, remove the brass nut on the flow controller using a 1/2" wrench to stabilize and 9/16" wrench to turn cap as pictured below.



- 7) Open the canister valve counter clockwise **no more than 1/2 turn** to begin sampling. Attempts to open the valve further can lead to valve damage and sample loss. Each flow controller has been set to a predetermined flow rate.
- 8) When sampling is complete, record the final vacuum on the COC and then close valve by hand tightening clockwise. **Do not use tools to tighten valve.**
- 9) Record final vacuum level on COC. Target final is about 5"Hg.
- 10) Detach flow controller by pulling back the sleeve of the female QT fitting and lifting the filter/gauge pair off of the canister.

- 11) Complete the Chain of custody (COC). Write the serial # or barcode circled below from the base of the canister. This number must be entered exactly as shown onto the COC to ensure no canister discrepancies are present upon receipt by the lab.



- 12) Make sure all canister tags are filled out and match COC. If cans are unused, please write “unused” on tag.
- 13) Notify your Eurofins Air Toxics Project Manager via phone (1-800-985-5955) or email ([Airtoxics@EurofinsUs.com](mailto:Airtoxics@EurofinsUs.com)) prior to sample delivery if rush TAT analysis is requested.
- 14) Safely pack all sampling media and COC’s in boxes and return to the lab.

### **Integrated Sampling Setup (with flow controller)**

- 1) Connect your flow controller to the canister by pulling back on the sleeve of the female QT fitting.



- 2) Place the female end of the QT fitting over the male QT fitting located on the top of the canister.



- 3) Release the sleeve once fully seated. Gently pull up on flow controller to make sure the fittings are properly connected.



When the male and female QT air valves are connected, the two devices they connect can freely rotate. **This is normal and does not indicate a problem with the connection or the integrity of the seal.** However, applying a lateral force to the valve while rotating may result in the loosening of the threaded cap found on the end of the male QT air valve. This threaded cap has been installed using a specific torque. While this torque should be sufficient to prevent the cap from being unthreaded during normal use, it is strongly recommended that the male QT air valve not be rotated if lateral force is applied.

- 4) Verify initial vacuum of the canister. The initial vacuum should be **greater than 25 "Hg**.
  - a. Confirm that valve is closed (knob should already be tightened clockwise)
  - b. Attach vacuum gauge or flow controller (brass cap will be installed on Swagelok end)
  - c. Open and close valve quickly.
  - d. Record initial vacuum level ("Hg) on the COC.

- e. If a shut-in test is required, monitor the vacuum reading per project requirements prior to removal of brass cap

**Note:** Gauges fitted with Quick Connect fittings will hold residual vacuum after disconnecting from the canister. If you are using the same vacuum gauge to check vacuum levels of multiple canisters, you may want to release this vacuum between readings. Using a 9/16" wrench, loosen the brass nut located on the gauge. This will return the gauge to zero. Retighten the brass cap and the gauge will be ready for the next vacuum check.

- 5) Attach all tubing, fittings, and/or purge cans to flow controller if necessary.
- 6) To begin sampling, remove the brass nut on the flow controller using a 1/2" wrench to stabilize and 9/16" wrench to turn cap as pictured below.



- 7) Open the canister valve counter clockwise **no more than 1/2 turn** to begin sampling. Attempts to open the valve further can lead to valve damage and sample loss. Each flow controller has been set to a predetermined flow rate.
- 8) When sampling is complete, record the final vacuum on the COC and then close valve by hand tightening clockwise. **Do not use tools to tighten valve.**
- 9) Record final vacuum level on COC. Target final is about 5"Hg.
- 10) Detach flow controller by pulling back the sleeve of the female QT fitting to release the seal. Uncoupled QT fittings act as a closed valve and will not allow air flow. Lift the flow controller off of the canister.
- 11) Complete the COC. Write the serial # or barcode circled below from the base of the canister. This number must be entered exactly as shown onto the COC to ensure no canister discrepancies are present upon receipt by the lab.



- 12) Make sure all canister tags are filled out and match COC. If cans are unused, please write “unused” on tag.
- 13) Notify your Eurofins Air Toxics Project Manager via phone (1-800-985-5955) or email ([Airtoxics@EurofinsUs.com](mailto:Airtoxics@EurofinsUs.com)) prior to sample delivery if rush TAT analysis is requested.
- 14) Safely pack all sampling media and COC’s in boxes and return to the lab.

### **Media Handling Rules**

Regardless of the type of canister samples collected, the following rules apply:

- 1) ***Do not handle or carry canisters by the valve.*** This can lead to accidental contamination of sample or loss of initial vacuum.
- 2) ***Do not transport canisters with flow controllers attached.***
- 3) ***Do not carry coupled flow controllers and canisters by the flow controller.*** Flow controllers cannot support the weight of a 6L canisters, fittings will bend or even break, maintain upright position during sampling.



## Chapter 3. Common Sampling Procedures

### 3.1. Purpose

This chapter presents specific sampling procedures and items common to the sampling events covered in Chapters 4 – 12. Section 1.5 and Figure 1-1 of this handbook illustrate the relationships among these chapters. Additional references include facility standard operating procedures (SOPs) and special requirements contained in regulatory programs and site permits.

### 3.2. Preparations for Field Sampling

The success of a field sampling program depends on the level of preparation prior to entering the field. Implementation of the SAP begins with preparing for the field sampling operation. The following preliminary steps are vital to the success of the project:

- **Preliminary Off-Site Evaluation.** Prior to implementing the SAP, the Program Manager and Health and Safety Supervisor should review any Historical Overview and Site Description sections of the SAP. This review may result in the decision for an on-site evaluation to assess the sampling procedures, relevant safety equipment, and PPE.
- **Equipment Verification.** The SAP should specify an equipment list, including sampling equipment, sample containers, and PPE. This list should be reviewed in detail by the entire sampling team and the Health and Safety Supervisor to verify that necessary items are included and appropriate for the site being sampled.
- **Inventory.** The Equipment Technician (however named) shall gather all the specified equipment and containers into one place and verify that it is on hand. Reagents, supplies, and quality control materials shall be checked and verified as appropriate. The designated technician shall notify the Program Manager that equipment preparations are complete.
- **Sign-Over of Materials.** The designated individual shall check the equipment inventory, and sign for custody if required.
- **Staffing and Scheduling.** The Program Manager shall consider the impact of specified sampling requirements on staff and schedule.
- **Screening or Field Measurements.** Sample screening or field testing for pH, dissolved oxygen (DO), sulfite, conductivity, disinfection chemicals, and temperature require additional field time. The need for additional personnel is based on time demands, training requirements and degree of difficulty. Significant field testing requirements may justify the procurement of a field laboratory and a trained field chemist to relieve other team members of this responsibility.
- **Preservation.** Preservation, either chemical or thermal, is required for most water samples. Thermal preservation usually requires icing the samples after collection and storing samples at  $\leq 6^{\circ}$  Celsius (C). For chemical preservation, two practices exist for adding preservative: 1) addition of the chemicals to the samples in the field, and 2) addition of the chemicals to the sampling containers prior to sending the containers to the field. Adding the reagents to the sample containers at the time the samples are collected requires the sampler to maintain records of addition and quality of the reagents and to follow proper chemical handling techniques. In some cases it may be advisable to have the laboratory add the reagents to specially labeled sample containers before they are sent to the field. This may reduce the fieldwork required and the possibility of field error resulting from contaminating the preservatives. Addition of the correct amount of preservative can be estimated for samples collected on a routine basis having little to no outside environmental or process effects.

---

**WARNING:** When using containers filled with preservative, use caution when filling the bottles to ensure the preservative is not released to the environment and the correct amount of preservative has been added to adequately fix the sample.

- **Time.** Many samples have short holding times prior to analysis. Review the holding time requirements and coordinate the schedule with the laboratory so the samples are analyzed within the required holding times. Holding times are dictated by the regulatory program and data may be invalidated if holding times are not met.

---

**Note:** Refer to Appendix B of this handbook for specific information on hold times, preservation, and containers.

### 3.2.1. Preparing for a Sampling Event

Preparing for a sampling event requires planning and a thorough knowledge of the regulatory program. The key elements for such preparation include:

- **Objectives.** The objectives should be thoroughly understood by all sampling personnel prior to sample collection. Knowledge of the compliance scope, boundaries, geography, and area roads and bridges will facilitate sampling.
- **Map of Study Area.** A map of the study area is essential for sampling. The map should be detailed enough so that sample locations and landmarks are clearly identifiable.
- **Permits and Regulations.** The person collecting samples should have a working knowledge of applicable permits, required monitoring, and other specified conditions. Regulations that potentially impact the sampling area, such as right of entry, should be reviewed by the sample collector.
- **Waste Sources.** When the objective of a project is to determine the nature, extent, or impact of a waste source upon an environmental medium, knowledge of waste source(s) within the area, as well as those sources upstream or upgradient that may impact the area, is essential. This knowledge entails knowing waste source discharge points or areas, type of waste, volume of discharge,

and constituent concentration. When this information is not readily available, it may be necessary to collect background information.

- **Environmental Medium Characteristics.** If the study is of a waterway, the physical characteristics of the waterway should be known prior to sample collection. These important physical characteristics include whether the receiving waterway resembles a lake, reservoir, pond, small stream, or a river. Average and maximum recorded flow, width and depth, type of benthic substrate, and type of predominant aquatic vegetation also should be noted.
- If the study area is limited to land, it is important to have knowledge of the terrain, soils classification, geology, terrestrial vegetation, industrial and residential development, predominant land use, and wildlife.
- **Sampling Information.** A sampler must know the types of samples to be collected, (e.g., water, wastewater, soil, or solid waste). The sampler also must know whether the samples are to be collected nocturnally or during the daytime, and where within the environmental medium the samples are to be collected (including both horizontal and vertical collections) as well as the preferred method of collection.
- **Laboratory Arrangements.** Arrangements must be made with the analytical laboratory to ensure that the laboratory is expecting the samples when they arrive and has a description of the types of samples (e.g., liquid, semi-solid, solid, or biological), an approximation of the number of samples for each sample type, and the analyses requested on each sample type. Arrangements must be made for the appropriate number of sample containers and preservatives where required. Regulations on transportation of samples from the point of collection to the laboratory must be considered, and the COC record must be traceable, as detailed in the SAP.

- **Equipment.** Prior to going to the sampling location, the sampling gear should be examined to ensure that it is appropriate for the task and in good working order. Verify that any preventative maintenance has been completed according to the SOPs. Label, mark, and otherwise identify all equipment, instruments, reference materials, and associated supplies for measurement processes to indicate calibration or standardization status. Expiration dates of reagents and solutions should be checked and verified as to usability. If a boat is required, an appropriate boat, motor, and life jackets must be available, and preliminary boat launch locations should be known before going to the sampling site. All equipment should be examined prior to starting the sampling event.

---

**Note:** When in use, sampling equipment should be anchored to prevent loss in the event the rope or equipment slips through the hands of the sample collector.

- **Safety.** The safety of sampling personnel is paramount. During wading operations, a rope should be attached to the sampler and extended to an anchored person on shore. In boating operations, at least two people should be present, one to collect the samples and another to operate the boat motor. Boat personnel are required to wear life preservers and take care to avoid overloading the craft. When collecting samples, beware of snakes, stinging insects, ticks, or other animals that may cause injury to the sample collectors.
- **Personnel Transportation and Lodging.** The Program Manager must consider arrangements for transporting sampling personnel and equipment to the sampling site, and for lodging when the sampling extends beyond a working day.

### 3.2.2. Preliminary On-Site Evaluation

When sampling for the first time at a new location, a preliminary on-site evaluation should be conducted prior to the sampling event to ensure that all aspects of the sampling process are addressed.

Upon arrival at the site, the Program Manager (or designee) and the Health and Safety Supervisor shall check with facility personnel to determine whether there have been any recent changes at the sampling locations that would influence the SAP or modify the expected hazards.

### 3.2.3. Preliminary Site Safety Evaluation

After a preliminary hazard analysis, sampling locations should be inspected to develop the Safety Plan or HASP as appropriate to the scope of the project. PPE information specified may not be completely reliable, and additional air monitoring may be required. When air monitoring activities are needed, focus first on identifying conditions that present an acute health hazard, and then evaluate exposure to chemicals such as carcinogens that could create long-term health problems.

If samples are to be collected in a confined spot, testing the air within the space for oxygen content should be a priority. Tests for explosive levels of flammable vapors should be conducted next, followed by testing for the presence of hazardous concentrations of specific toxic agents (depending upon the nature of the space and its contents or previous contents).

---

**Note:** Real-time instrumentation is available for making these measurements. Air samples should be collected to evaluate the levels of other chemicals in the air that may require respiratory protection. Some organic chemicals such as gasoline vapors can be monitored with standard field instruments. However, monitoring for carcinogens will normally require the use of a field gas chromatograph or the collection of test samples for laboratory analysis.

In general, the air monitoring program to evaluate worker exposures to toxic chemicals should be designed by an industrial hygienist familiar with the facility and potential hazards to which the field sampling team will be exposed.

Review physical hazards that may be present at the site, such as unstable footing near river embankments, water safety practices, first aid supplies, equipment safety practices, and other physical hazards.

### 3.2.4. Explosive Safety Evaluation

The possibility of encountering explosive hazards must be considered in all sampling plans. When the presence of energetic materials is suspected from the history of a site, appropriate precautions can be incorporated during the planning stages.

Consideration should also be given to situations that can lead to the formation of unstable materials from constituents that are not originally energetic compounds. Formation of peroxides in ethers and metal picrates are two examples that have been known to create safety hazards.

### 3.2.5. Preliminary Sampling Evaluation

Sampling locations should be inspected to ensure the information in the SAP is correct. All equipment should be checked prior to mobilization and the day before the sampling event to ensure proper equipment operation, parts, and records are available for the sampling operation. If needed, preventative maintenance should be performed.

Reagents, supplies, reference materials, and consumable materials should be verified as to expiration dates, quality, and applicability to the assigned equipment.

Locate all the sample locations during the on-site evaluation to determine site accessibility with the designated equipment, sample location, and possible background contamination for the contaminants of interest. Electromagnetic interferences, volatile air pollutants from locations off site, weather, and climate may affect the sampling event and should be planned for, as much as practical, to avoid delays in sampling.

### 3.3. The Sampling Event

A typical sampling event should include the following sequential activities:

- Complete all preparation and preliminary evaluation activities as needed
- Arrive at the sampling site with appropriate equipment, supplies, materials, and sample containers
- Set up equipment, work areas, and safety areas, as described in the SAP

- Collect samples at the locations specified in the SAP or reference procedure
- Immediately following sample collection, ensure that each sample container is labeled as described in the SAP. The sample label must be traceable to the sample number, date/time sampled, sampler's name, preservative, and site name, location or unique project identifier.
- Document the exact location of the collected sample(s) in the field logbook or field notebook (FLB/FN). Also, record in the FLB/FN other observations of environmental conditions that could affect or contribute to knowledge of the sampling area and the environment where the sample is collected. Prevailing weather conditions at the time of sampling should also be recorded.
- Preserve or ice samples as appropriate and record preservation method
- Perform field tests or field screening measurements and record all observations in the FLB/FN
- Complete the COC record and other field records
- Pack and seal the shipping container with collected samples, and transport the shipping container with the COC record and any laboratory required forms to the laboratory. Retain copies of all transmitted forms.
- Return all forms and copies of relevant FLB/FN pages to the Program Manager or designee
- Clean sampling equipment for the next sampling event or storage
- Breakdown all work area and safety areas as required and return the site to the condition found at the start of the sampling event
- Dispose of all waste materials using appropriate procedures.

### 3.4. Sampling Procedures

The SAP refers to detailed sampling procedures or includes the details of the sampling operation. A standard SOP format should be used to incor-

porate the following items for each type of sampling operation:

- Sampling locations, sample numbers or identifiers
- Type, volume, and number of sample containers to be filled at each sampling location and the records to be maintained
- Contaminants to be measured and special handling procedures to ensure proper collection
- Safety, health, and hazard cautions
- Sampling equipment (construction material, type, etc.) and records to be maintained for status, maintenance, and corrective action
- Step-by-step sample collection procedures (grab, composite, continuous for specified period, etc.)
- Sampling frequency for repeated sampling at the same sample location
- Special sampling requirements (e.g., the collection of initial runoff samples after a rain for contamination)
- Sample handling procedures for each sample container (e.g., screened, filtered, sequence for filling groundwater sample containers, etc.)
- Preservatives required for each sample container and contaminant
- Reagents, supplies and support services quality, verification and validation criteria to ensure materials are used properly
- Equipment decontamination procedures to be used between sample locations and between sampling events
- Recordkeeping requirements, documentation handling, and retention requirements
- Sample, equipment, and materials storage requirements
- Provisions for storage or disposal of wastes generated during field sampling.

#### 3.4.1. Sampling Strategies

See Appendix A for sampler and sampling recommendations and strategies for waste materials. Sampling strategies for drinking water, wastewater,

groundwater and TSCA materials are permit or compliance dependent. The Scope or Purpose section of the sampling procedures should describe the rationale for the sampling strategy to ensure that all personnel involved with the project have an understanding of the sampling event.

#### 3.4.2. Sampling Procedure Checklist

Following is a checklist of the minimum steps to address in SOP format.

- **Sampling Approach**
  - Objective
  - Design of sampling plan
  - Statistics
- **Material to be Sampled**
  - Physical state
  - Volume
  - Hazardous properties
  - Composition
- **Site**
  - Accessibility
  - Waste generation and handling
  - Transitory events, startup, shutdown
  - Maintenance
  - Climate
  - Hazards
- **Equipment**
  - Maintenance
  - Preparation and cleaning
  - Operation
  - Calibration and standardization
- **Sample Handling, Transportation, Storage and Preservation**
  - COC
  - Seals
  - Forms
  - Containers
  - Preservatives, reagents, and supplies
- **QA/QC**
  - Controls on process
  - Audits
  - Training
  - Samples, blanks, duplicates, and spikes
- **Health and Safety**
  - Personnel protection

- Safety procedures
- Emergency procedures
- **Laboratory**
  - Document transfer
  - Sample arrival schedule, transfer
  - Sample preservation, handling and storage
  - Analytical methods and QC
  - Reporting format and schedule.

### 3.5. Sample Documentation and COC Procedures

Thorough documentation of a sample's custody is required to support sample validity. The documentation must verify that the samples are representative, were collected in accordance with the requirements of the SAP, and are not vulnerable to tampering before being received by the laboratory. The COC begins when the sample is taken and ends when the sample is disposed of. Sample documentation and COC procedures include the following.

- A completed sample collection label attached to all sample containers
- Records of sampling operations written in FLB/FN or related forms as designated for the operation in the SAP. Records include sample type, sample matrix, sampling method, field test methods, and QC procedures. A table may be used to present this information.
- Identification of every sample container on a COC record and all custody transfers documented
- Custody of the samples with all discrepancies in the field operations resolved or duly recorded.

The following should be used to generate the required sample documentation.

---

**Note:** EPA's "Field Operations and Records Management System II Lite (FORMS II Lite™)" software is an electronic COC and may also be used to simplify and accelerate the sample documentation process.

#### 3.5.1. Pre-Assigned Sample Numbers

Each sample consists of all of the material collected for analysis at one place, at one time, and of one

matrix, except for composite samples, which may contain components collected at different locations or time.

The Program Manager shall establish a system for assigning a unique sample number to each sample collected in the field. The numbering system will be defined in the SAP, in case additional samples are generated in the field. The number for each sample will be used to identify the sample in the FLB/FN, on the sample container, and on the COC record. The number may be used on other forms and reports presenting measurements, test data, or evaluations.

The sample numbers of field QC samples like a field duplicate should be transparent to the laboratory. The sample numbers should not reveal whether a sample is a blank sample or two field samples are duplicate/split pairs to avoid potential biasing of analytical results.

The sample number provides a common identifying code for all of the analytical results for a single sample. This is particularly useful when the results are entered into a computer database, which should include:

- Sample number
- Sample container number
- COC record number
- Matrix
- Location
- Sample type
- Sample date and time
- Sampler's name
- Parameter
- Analytical result
- QC data
- Compliance limit and
- Data qualifier code (optional).

Results from analysis of trip blanks, field blanks, equipment decontamination blanks, split samples and MS/matrix spike duplicate (MSD) samples may be entered into a computer database. In some testing programs, these results are used to

generate the data qualifier code for the analytical results from test and duplicate samples.

It is recommended that the information associated with each sample number consists of elements describing the sample type, matrix, location, and the time and date of sample collection as required.

---

**Note:** If the sampling and analytical data are to be added to an existing database, sample numbers should be consistent with database requirements.

### 3.5.2. Sample Container Labeling

Sample labels are an important part of proper documentation to reduce the possibility of confusing sample containers, and to provide the necessary handling information. Sample containers should be pre-labeled as much as practical before sample collection. The labels may be protected from the sample matrix with a clear tape covering. For volatile samples, check with the laboratory to ensure that any labels being used do not interfere with their auto-samplers. Sample labels should include sample number, date and time sampled, location, sample type, preservative and the sampler's initials or signature.

Sample numbers may be unique to the sample location, to the sample type or to the container. In some labeling processes, a unique sample number is written on the container label, and all information recorded on the accompanying form(s) is traceable to the unique sample number.

Some number schemes uniquely number each sample container. All data reported for the sample includes the sample container number for traceability to the container measured. This is useful when sample containers are cleaned and lot controlled, and traceability from container preparation, preservation, sampling, and testing is required.

A designated Field Sample Custodian or sampler should label the sample containers when they are filled. Preprinted, adhesive, multiple part labels formatted as shown in Figure 3-1 may be used. Each part includes the unique sample container number that may be pre-numbered to avoid duplication.

---

**Note:** Because 40-mL volatile organic analysis (VOA) vials may be stuck in an autosampler, the field sampling team leader needs to contact the laboratory to make sure if applying a clear tape over a sample label of 40-mL VOA vials is acceptable. Use waterproof ink to make label entries. FLB/FN notations should provide an explanation if a pencil was used to fill out the sample container label due to field weather conditions. Because waterproof ink may contain target VOAs such as xylene, toluene, or alcohols as a solvent, great care is needed to prevent VOA samples from contamination by the solvent of waterproof ink or permanent marker.

**Figure 3-1. Multiple Part Container Label**

<b>PROJECT NAME</b>	
Sample #: XXXXX	
Container #: XXXXX	
Sample #: _____	
Date: _____	Time: _____
Location: _____	
Cont. Size: _____	
Cont. Type: _____	
Matrix: _____	
Type of Sample: _____	
Preservative: _____	
Signature: _____	

### 3.5.3. FLB/FN

The FLB/FN is the written record of all field data, observations, field equipment calibrations, and sample collection activities. Potential for future legal actions dictates that the FLB/FN be site-specific and that they be hardbound (e.g., ledger, composition book, diary, etc.). All pages (front and back) shall be serially numbered so removal will be apparent. Samplers shall adhere to the following guidelines when using FLB/FN.

- The FLB/FN shall be assigned to the QA/QC Coordinator or designee. Additional log books may be assigned by the Program Manager or designee to the Field Chemist and the Health and Safety Supervisor. The QA/QC Coordinator or designee shall note in each FLB the individual to whom it was assigned. The FLBs may be controlled by the QA/QC Coordinator or the Program Manager.

- Each FLB shall be annotated with the sampling program name or number.
- Key personnel and telephone numbers shall be listed on the first page.
- Entries shall be written in waterproof blue or black ballpoint pen. Avoid felt tip pens. *Do not use pencil.*
- Start a new page at the beginning of each day.
- Entries should be chronological – a time notation should introduce each entry.
- Sketch or obtain a map of the area or facility. Include sketches of layout, structural features, and points of interest or contamination. Include a north arrow and a rough scale. If possible, obtain a site map (reduced if necessary) and permanently place it in the FLB/FN.
- Language should be objective, factual, and free of personal feelings or other inappropriate terminology. Speculation or personal observations may be included if they are clearly identified as such.
- Do not erase or scratch out errors. Draw a single line through the error, then insert corrected material. The person who made the error shall initial and date the correction as well as clearly state the reason for the error.
- Entries or corrections made by individuals other than the person to whom the FLB/FN was assigned shall be signed and dated by the individual making the entry or correction. An explanation for the correction should be noted.
- The last entry for each day should include a short summary of the day's activities, weather conditions and the time the site was left. As appropriate, the last entry for each week should be a summary of the week's activities. Weekly summaries should be thorough and descriptive.
- The FLB/FN shall be signed at the end of each day. Signatures shall be written on a single diagonal line drawn across the blank portion of the page following the day's last entry.
- All FLBs/FNs shall be returned to the individual designated for review and final storage when sampling is completed as described in the SAP.
- FLB/FN entries will contain a variety of information. Information to be entered at the start of each day of sampling includes the following:
  - Date of the sampling event
  - Time sampling started and approximate time for set up of equipment
  - Weather conditions
  - Level of PPE being used
  - Names of field sampling team members and others present during the sampling.
- Fully document all deviations from the SAP or changes in sampling procedures. Problems, delays, or any unusual occurrences such as improper equipment or breakdowns should be included, along with resolutions and recommendations. Summarize the content and conclusions of all relevant meetings, discussions, and telephone conversations in which you are involved. Include the names and affiliations of all personnel involved. Thoroughly document all directives and/or guidance from EPA or other government personnel. Directives that give personnel specific authority to make critical decisions must be documented in the FLB/FN.
- Whenever a sample is collected or a measurement is made, a detailed description of the location must be recorded. The source from which the sample is collected should be clearly identified to maintain traceability and allow another person to locate the exact sampling location. The ability to relocate the sample site ensures duplication of future sampling events. Measurements from permanent features (e.g., center line of road, numbered utility pole, etc.) to the sample point must be made and entered into the FLB/FN. Coordinates on a map, or an accurate site sketch with distance measurements to known locations are other options to ensure the exact location of each sample is recorded.



- Describe the site thoroughly so another person will be able to locate the exact sample location. Note signs of contamination such as oily discharges, discolored surfaces, unusual odors, dead or distressed vegetation including types of plants, if possible. Photographs may be taken to provide evidence of visual observations, record site conditions, and assist with locating the sample site in the future. Photographs taken of sample locations should be noted along with the picture number. Log the record in the FLB/FN to identify which sampling site is depicted in the photograph.

---

**Note:** A series of photographs can be identified by taking the first photograph of an informational sign with the sampling program name, number, and the project number on it.

- Each time a sample container is filled and labeled, a copy from the multiple part form of the sample container label or reference number label with all information recorded shall be put into the FLB/FN.
- All equipment used to make measurements must be identified by type, manufacturer, and serial number, along with the date of calibration. Details of field calibration procedures and results shall also be included in the FLB/FN.
- Note decontamination or disposal procedures for all equipment, samples, protective clothing, and personnel decontamination procedures.
- For each delivery or shipment of samples to a laboratory, record the following information in the FLB/FN:
  - Custody procedures and serial numbers
  - Packing and shipping procedures (record air bill numbers)
  - Name, address, telephone number, and contact of the laboratory performing the analysis.

---

**Note:** The laboratory address should be the sample receipt address, which may not be the same as the mail receipt address.

### 3.5.4. Field Notes/Field Sampling Forms

Field notes or field sampling forms are used in addition to or in lieu of field log notes. When field notes are used in lieu of an FLB, the record keeping practices presented in Section 3.5.3 should be followed. The field form provides a place for the sampler to record the information required for the project. Field forms are specially designed for any given project and may be completed one per sample or one per sampling event. The forms include blank lines for recording the information necessary for the project to ensure the proper information is recorded. All blanks must be completed on a field form to ensure proper documentation. The sampler completes the field form for all samples collected including QC samples. An example of a field form for a well sampling activity is presented in Figure 3-2 below.

---

**Note:** A review of the regulatory program's specific requirements must be conducted to ensure that all documentation requirements are met. Some programs do not allow the use of loose field forms as the sole documentation vehicle and require hardbound logbooks.

The field form lists the sample number, location, matrix, the type and number of sample containers filled (including QC samples), any chemical preservatives added and checked for each sample container, sampling procedure reference, deviations to the procedures and all field measurements and observations.

The Field Sample Custodian indicates acceptance of the information on the field form by signing and dating the form. In cases where multiple part forms are used for the sample label, for each sample container filled, one part of the multiple part adhesive sample container label is placed on the field form at the appropriate location. The completed field forms are returned to the Program Manager as soon as possible and by the means indicated in the SAP. Deviations or problems encountered during the sampling event must be communicated promptly in writing to the Program Manager or designee. This may be completed by sending the field form by facsimile or other means to communicate the deviations, as

well as allow for continuation of the project and ensure sample holding times are not jeopardized.

---

**Note:** The field form becomes part of the permanent project records, but is not usually sent to the laboratory.

### 3.5.5. Chain of Custody (COC)

An overriding consideration for environmental measurement data is the ability to demonstrate that samples have been obtained from the locations stated and that they have reached the laboratory without alteration. Documentation of security, field handling criteria, shipment, laboratory receipt, and laboratory custody until disposal, provides evidence of proper processing. The degree of custody documentation is dependent on the regulatory program, data use, and needs. Many state programs for sampling wastewater and drinking water do not require “legal custody,” but recommend legal custody whenever data is known to be used for evidence. A review of data use and risk of legal proceedings will dictate the type of custody procedure to be employed. Documentation consists of a COC record that is completed by the Sample Custodian.

#### 3.5.5.1. Field Custody Procedures

The Field Sample Custodian or sampler is personally responsible for the care and custody of the samples until they are transferred or properly dispatched. As few people as possible should handle the samples. A sample is considered to be “in custody” for legal proceedings if it is:

- In a person’s actual possession
- In view after being in physical possession
- Locked up so that no one can tamper with it after having been in physical custody
- In a secured area, restricted to authorized personnel only.

If any one of these is not in place at all times, the COC is broken.

The Program Manager or designee shall review all field activities to determine whether proper custody procedures were followed during the fieldwork and whether additional samples are required. The sampler or Sample Custodian shall notify the Program Manager of any breach or irregularity of COC procedures described in the SAP.

**Figure 3-2. Field Form**

Sheet <u>  1  </u> of <u>  1  </u>					<b>MICROPURGE/LOW-FLOW SAMPLING LOG</b>					
<b>PROJECT:</b>					<b>WELL ID:</b>					
EPA ID NO:					Well Condition:					
Proj./Task No.					Well Riser Dia. (ID):					
Date:					Screened Interval:					
Weather:					S.W.L. Measuring Pnt:					
Samplers:					Well Bottom Depth:					
Purge Method: Micropurge										
Sample Collection Method:										
Sampling Device:					<b>STATIC WATER LEVEL:</b>					
Tubing:					Initial Purge Volume:					
<b>Pump Intake Depth:</b>					Approximate Pump Throttle Setting:					
<b>Total Recovered Purge Water This Well:</b>										
<b>Groundwater Sample Data:</b>										
Sample ID	Analysis	Primary	QC	MS/MSD	Blank	Sample ID	Analysis	Primary	QC	MS/MSD
<b>Instrumentation/Equipment Data:</b>					<b>Calibration Date:</b>					
<b>Field Test Results:</b>					<b>Hach Kit Tests:</b>					
					D.O.		mg/L			
					Total Iron:		mg/L			
					Ferr. Iron:		mg/L			
					CO2:		mg/L			
<b>Comments:</b>										
Observations: Clarity:			Odor:		Floating Product:			Sheen:		
<i>PURGE WATER DATA TABLES</i>										
<b>Stabilization Parameters</b>	Units	Minutes	Minutes	Minutes	Minutes	Minutes	Minutes	Minutes	Minutes	
Temperature	C									
Sp. Cond.	ms/cm									
D.O.	ppm									
pH										
ORP (Eh)	mV									
Turbidity	NTU									
Clock Time										
Static W.L.										
Flow Rate	ml/min.									
<b>Stabilization Parameters</b>	Units	Minutes	Minutes	Minutes	Minutes	Minutes	Minutes	Minutes	Minutes	
Temperature	C									
Sp. Cond.	ms/cm									
D.O.	ppm									
pH										
ORP (Eh)	mV									
Turbidity	NTU									
Clock Time										
Static W.L.										
Flow Rate										

### 3.5.5.2. COC Records

From time of collection through final sample disposal, there are many transfers of custody during the course of a sampling program. All sample containers must be accompanied by a COC record to document these transfers. A separate COC record shall be prepared by the Field Sample Custodian or sampler for each sampling event. In some programs, a COC record accompanies each shipping container and includes a pre-numbered COC record. This record lists the sample containers that are in the shipping container, and serves as the packing list for the container. The serial number on the form becomes the identifying number for the shipping package.

Figures 4-3 provides an examples of a sample COC record. The example has been used for a wide variety of regulatory programs and meets legal COC requirements. It tracks the samples from sample collection to disposal. All sampling, preservative, and test information is included. The SAP will indicate the individual responsible for completing each section. The following information relates to the numbered blocks:

#### COC Record—Figure 3-3.

- (1) The **company/command** name and **code** for the source of the funding.
- (2) The **contact name** for the Program Manager or designee indicated in the SAP.
- (3) The **job order number (J.O. #)** is entered to trace the information to the specific job.
- (4) The **signature** of the Program Manager or designee authorizing the funds.
- (5) The **permit number (No.)**, if applicable, for the samples collected. The number is issued by the regulatory agency for specific compliance reporting.
- (6) The **sample ID/location** based on permit designations or actual site location name.
- (7) The **sample taken date and time** are recorded for grabs on the start line only and for

composites on the start date and time and stop date and time.

- (8) The code for **sample type** such as grab, composite flowing and composite time (see Section 18).
- (9) The initials for the **person sampled by**.
- (10) The code for **sample matrix** such as liquid, solid, and gas (see Section 18).
- (11) The code for **preservative** (see Section 18).
- (12) The **# of samples** and **container** type are entered as “4-P” for four plastic containers (See Section 18).
- (13) The **analysis** to be performed - may reference descriptions in the SAP.
- (14) The field reading for **pH** for the sample containers indicated.
- (15) The field reading for **temperature** with the unit of measure for the sample containers indicated. The SAP may indicate the temperature to be recorded in the outfall temperature and not the sample temperature.
- (16) The field reading for **other** required measurements may be entered with the unit of measure. The SOP and name of the test must be indicated on the custody form.
- (17) After the samples are preserved, the **preservation is verified**. The verification is noted per the SAP. This verification may be temperature, pH, or if all is correct an indication is made as “OK.”
- (18) This section of the custody form contains **common codes** to be used by the sampler when completing the custody record. When situations arise that do not match the code designations, alternates may be added for the one time use on the custody form.
- (19) The expected **turnaround** for sample request is placed in this area. The reason is presented to determine if the turnaround time is regulatory, project specific, or based on holding time requirements.

- (20) **Special instructions** or comments may be entered in this space.
- (21) The **regulation applied** to the project is checked.
- (22) The **sample collection/charge, possible sample hazard** and other **comments** relate to the command in charge of sampling, special sample hazards, or to other sample comments. Reference may be made to code or specific sections of the SAP.
- (23) The **delivery order number** is entered.
- (24) The **contract lab** and **contract number (No.)** are entered for testing work performed by a designated contract laboratory.
- (25) The **sample disposal** method and the date completed.
- (26) The signature and **company/command** of the person relinquishing custody (**relinquished by**).
- (27) The signature of the person custody is **received (rec'd) by**.
- (28) The **date/time** custody is transferred.

Figure 3-3. COC Record

**CHAIN-OF-CUSTODY RECORD**  
8 ANALYSIS REQUEST FORM

**ENVIRONMENTAL**

PWC ENVIRONMENTAL LABORATORY  
CODE 990 BLDG 2:140  
9142 MARYLAND A VENUE  
NORFOLK, VA 23511-3095  
PH: (004)4450951 FAX: (004)4450952

**CLIENT INFORMATION**

COMPANY/COMMAND: 1 CODE: \_\_\_\_\_

CONTACT: 2 EXT: \_\_\_\_\_ FAX: \_\_\_\_\_

PHONE: \_\_\_\_\_

J.O. #: 3

SIGNATURE: 4

PERMIT NO.: 5

LAB USE ONLY LINE ITEM #	SAMPLE NO	SAMPLE ID/LOCATION	SAMPLE TAKEN	ON DATE	AT TIME	TYPE	SAMPLED BY	MATRIX	PRESERVATIVE	# OF SAMPLES / CONTAINERS	ANALYSIS	FIELD READINGS		PRESERVATION	
												pH	TEMPERATURE	OTHER	VERIFIED BY
	<u>6</u>		START	<u>7</u>		<u>8</u>	<u>9</u>	<u>10</u>	<u>11</u>	<u>12</u>	<u>13</u>	<u>14</u>	<u>15</u>	<u>16</u>	<u>17</u>
			STOP												
			START												
			STOP												
			START												
			STOP												
			START												
			STOP												
			START												
			STOP												
			START												
			STOP												

**LAB USE ONLY**

18. TYPE OF COMPOSITE FLOW: 18 L - LIQUID S - SWIPE  
G - GAS S - SOLID SS - SEMI SOLID

19. TURNAROUND: (FOR RUSH TURNAROUND STATE REASON BELOW) SPECIAL INSTRUCTIONS: 20

21. REGULATION APPLIED: RCRA ( ) HSD ( )  
SDWA ( ) TSCA ( )  
CWA ( ) PHOTO ( )  
CAA ( ) OTHER ( )

22. SAMPLING/COLLECTION CHANGE: \_\_\_\_\_  
POSSIBLE SAMPLE HAZARDS: \_\_\_\_\_  
COMMENTS: \_\_\_\_\_

23. D.O. NUMBER: \_\_\_\_\_  
CONTRACT LAB: \_\_\_\_\_  
CONTRACT NO.(S): 24

25. SAMPLE DISPOSAL: ( ) RETURN TO CLIENT ( ) DISPOSAL BY LAB

26. RELINQUISHED BY: \_\_\_\_\_ COMPANY/COMMAND: \_\_\_\_\_  
REC'D BY: \_\_\_\_\_ DATE/TIME: 28

27. RELINQUISHED BY: \_\_\_\_\_ COMPANY/COMMAND: \_\_\_\_\_  
REC'D BY: \_\_\_\_\_ DATE/TIME: \_\_\_\_\_

28. RELINQUISHED BY: \_\_\_\_\_ COMPANY/COMMAND: \_\_\_\_\_  
REC'D BY: \_\_\_\_\_ DATE/TIME: \_\_\_\_\_

**CONTAINER**

A - AMBER (glass)  
B - BAG  
C - CARTRIDGE  
D - CAPTIONED LID  
E - HEAVY THINSE  
F - PLASTIC  
G - GLASS  
H - TETRA  
I - VIAL

**PRESERVATIVE**

1 - COOL TO 4C  
2 - HNO3, pH=2  
3 - H2SO4, pH=2  
4 - HNO3, pH=12  
5 - HCL, pH=2  
6 - DDBS, NAGS203, 4C  
7 - FIELD FILTER  
8 - NONE

The COC record identifies which pairs of sample containers were collected for the same analysis, and identifies the sample containers that were filled with sample for use as the MS/MSD QC samples. Based on the needs and data use, the COC record may not list any information as to the exact sample location or whether a sample is a field duplicate, field blank, trip blank or an equipment decontamination blank. This information is kept as blind information from the laboratory to ensure objective reporting. When this process is used, records must be maintained that trace the sample collected in the field with the sample as identified to the laboratory. Compliance data for drinking water or wastewater testing do not require blind submissions. The QC sample information is provided to the laboratory to ensure prompt notification when the QC data does not meet the SAP specifications.

Whenever samples are split with a second laboratory or government agency, a separate COC record may be prepared for the second set of samples. The additional set of COC records must be noted. Copies of the original may be sent with the split samples noted, or a separate form may be prepared by copying the appropriate information for the samples onto the additional form. In all cases, the use and need of the additional form should be noted.

Upon completion of the packing of each shipping container, the Field Sample Custodian shall confirm the completeness of the COC record by signing the COC record. If a multiple-part form is used:

- The original copy is put into the shipping container
- The first copy is sent immediately (preferably by fax) to the Program Manager or designee
- The second copy is kept with the FLB/FN or copy of the field form.

If a single part form is used, photo copies should be made for the Program Manager and the FLB.

After the COC record is completed and all samples are packaged and shipped to the appropriate locations, the person relinquishing the samples to

the laboratory or agency shall request the representative's signature acknowledging sample receipt. If the representative is unavailable or refuses to sign, this is noted in the "received by" space.

Field COC terminates upon laboratory receipt of the samples. The laboratory should complete the "received by" sections and if appropriate, the "preservative checks" sections on the COC record and return the original signed record to the Program Manager. If there are any discrepancies between the COC record, the contents of the shipping container, and the SAP or contract requirements provided to the laboratory, the samples in question shall be segregated from normal sample storage, and the laboratory shall immediately notify the Program Manager. In some cases, the laboratory checks the sample submittal and recordkeeping to ensure adherence to the SAP. This added check is often used in drinking water and wastewater testing programs for compliance monitoring. Recordkeeping and information checks should be performed by the laboratory to ensure the samples received meet the requirements of the SAP.

### 3.5.5.3. Custody Seals (Optional)

Custody seals are narrow strips of adhesive paper used to indicate whether a shipping container has been opened during shipment. The seals are placed along the edges of the most exterior container in which samples are enclosed. It is not always necessary to place seals on individual sample containers in the shipping container.

Paper custody seals should be signed and applied before the shipping container is shipped to the laboratory. The preferred procedure includes use of a custody seal attached to the front-right and back-left of the container. Custody seals are covered with clear plastic tape. Another way to use custody seals, is to put all sample containers with packing and ice in a large garbage bag and seal the garbage bag with a signed custody seal.

### 3.5.5.4. Custody Transfer

Transfer of custody and shipment procedures are as follows.

- Each sample shipping container shall be accompanied by a properly completed COC record. The original of the record shall be included in the container. The Field Sample Custodian shall keep a copy of the completed form as part of permanent documentation and will send a copy of the COC record to the Program Manager.
- When transferring possession of samples, individuals relinquishing and receiving shall sign, date, and note the time of the transfer. This record documents custody transfer from the Field Sample Custodian to another person, to a mobile laboratory, to the permanent laboratory, or to a secure storage area.
- If the sample container is sent by common carrier, a bill of lading shall be used. Bill of lading receipts shall be sent to the Program Manager for permanent retention. If sent by mail, the package shall be registered with return receipt requested. Commercial carriers and the U.S Postal Service are not required to sign off on the COC record as long as it is sealed inside the package with the sample container and the custody seals remain intact (if used).
- Authorizes the payment for the analyses
- Alerts the laboratory to any anticipated hazards associated with the samples and custody procedures to be followed while the samples are in the possession of the laboratory
- Specifies the reporting requirements and content for the final report from the laboratory
- Instructs the laboratory as to the disposition of the samples after the completion of the analyses.

### 3.6. Sample Packaging, Handling, and Transportation

The Field Sample Custodian is responsible for the proper field storage, security, packing, and shipping of the samples from the field to the laboratory or designated holding location. The packaging, labeling, and shipment of samples by common carrier are regulated by the DOT and the International Civil Aviation Organization (ICAO)/International Air Transport Association (IATA), when appropriate. Instructions for classification, labeling, and packaging of hazardous materials are contained in DOT regulations (49 CFR 172 and 173, and subsequent Parts). Overnight couriers generally accept materials shipped under these regulations. However, some couriers have additional restrictions for hazardous shipments. EPA also regulates the shipment of hazardous waste and hazardous material by requiring labeling on certain packages.

The procedure for determining whether a sample is hazardous under DOT regulations is complex, as is the determination of the proper shipping name, packaging requirements, and labeling requirements for DOT hazardous materials. A summary of specific requirements are addressed below. Should questions arise, assistance is available from the DOT (1-202-366-4000) and Federal Aviation Administration (FAA) (1-866-835-5322) hotlines.

Samples obtained at sites are classified for shipping purposes as either environmental (non-hazardous) samples or hazardous samples. If a material is being shipped for testing to determine its hazards, a tentative hazard class assignment

#### 3.5.6. Request for Analysis

The Request for Analysis form is often incorporated into the COC record since the chain must accompany the samples. In more complex sampling programs, an additional form may be used to request testing.

When contracting for laboratory services and prior to submitting the samples, the laboratory should be contacted and the following information presented. The Request for Analysis form can be used as a preliminary contact mechanism to ensure that the scope of work is understood. This form:

- Specifies the analyses, procedures, and QC data to be performed on each sample container and the compliance protocols to be followed
- Specifies the laboratory accreditation/certification required to be maintained during the period of the contract



should be made based on knowledge of the material. Samples requiring special packaging or labeling are those containing chemicals that are listed as hazardous materials in:

- 49 CFR 172.101
- CERCLA RQ Hazardous Substances
- DOT CLASS 9 listed in 49 CFR 172.101 Appendix A, Poison DOT Class 6.1 and Flammable Liquids.

Environmental (non-hazardous) samples are those that are not classified as Hazardous Materials under DOT regulations, are packaged in quantities less than the CERCLA RQ, *and* for which a Hazardous Waste Manifest is not required by EPA. These samples require careful packing, but no special shipping procedures. In general, samples of groundwater, surface water (other than leachate or lagoons), and soil may be shipped as environmental samples (non-hazardous) to an analytical laboratory for testing if each of the sample containers contains less than 1 pound of soil or 1 gallon of water, and the entire shipping package weighs less than 66 pounds. Eventual analysis for a hazardous constituent does not necessarily classify a sample as a DOT hazardous material, nor does the classification of a material as a hazardous waste under EPA regulations. DOT regulations forbid the shipping of non-hazardous materials as hazardous. However, if any doubt exists as to whether the sample might be classified as a hazardous material, the sample should be treated as hazardous.

---

**Note:** For details on the shipping of non-hazardous waste, refer to *ASTM D6911-03: Standard Guide for Packaging and Shipping Environmental Samples for Laboratory Analysis*. This standard provides guidance in determining the most appropriate procedures for packaging and shipping environmental samples.

The storage and disposal of hazardous waste is regulated by the EPA. Hazardous waste, as specified in 40 CFR 262, is not exempted from EPA manifesting requirements. However, EPA RCRA regulations exempt samples collected for analysis or treatability testing from the RCRA requirements that otherwise apply to hazardous waste (including the requirement for a Hazardous

Waste Manifest). The definitions for these exemptions are:

- **Samples for Analysis.** 40 CFR 261.4(d): Samples of solid waste, water, soil, or air, which are collected for the sole purpose of testing to determine their characteristics or composition, when samples are being sent to the laboratory for testing or are being returned to the collector after testing.
- **Samples for Treatability Testing.** 40 CFR 261.4(e): Samples collected for the purpose of conducting treatability studies when they are being transported to the testing facility provided they meet criteria for the quantity of material, packaging, and permit status of the receiving facility.

### 3.6.1. Sample Packaging Requirements

The Field Sample Custodian is responsible for the packing and shipping of the samples from the field to the laboratory. Samples shall be properly packaged for shipment and dispatched to the laboratory for analysis with a signed custody record enclosed in the shipping container box or cooler. Shipping containers shall be locked or secured with strapping tape in at least two locations. Shipments that are sent to an on-site laboratory or one in close proximity that does not require the use of a common carrier shall be transferred in accordance with local regulations. Table 3-1 below lists sample packaging procedures that will ensure samples arrive at the laboratory with the COC record intact.

The following major issues must be addressed in preparing environmental samples for shipment to the laboratory by common carrier:

- Compliance with EPA regulations, so the samples are not classified as hazardous waste
- Compliance with transportation regulations, including use of the proper shipping containers, use of warning labels, and completion of the required paper work
- Packing, to assure that the samples do not break or leak during shipping. This includes:

- Using approved containers meeting DOT drop test specification
- Lining coolers or containers with plastic bags
- For glass containers, wrapping each in bubble wrap and placing in a clear plastic resealable food bag
- For plastic containers, placing each in a clear plastic resealable food bag
- Never stacking glass containers or laying glass on its side.

### 3.6.1.1. Samples Classified as Flammable Liquid

Table 3-2 Column 1 lists packaging procedures that apply to those flammable and combustible liquids that do not meet the definitions of another hazard class except DOT Class 9, and for which exceptions under 49 CFR 173.150 are allowed. This includes Flammable Liquids Not Otherwise Specified (NOS), toluene, gasoline, and many of the other flammable liquids that are commonly encountered on hazardous waste sites.

**Note:** The DOT definition of “liquid” is different from that used by EPA. For purposes of transportation, liquid means a material that has a vertical flow of over 2 inches (50 mm) within a 3-minute period, or a material having 1 gram or more liquid separation, when determined in accordance with the procedures specified in *ASTM D4359-90, Standard Test Procedure for Determining whether a Material is a Liquid or Solid*, (49 CFR 171.8).

### 3.6.1.2. Samples Classified as Poison — DOT Class 6

Table 3-2 Column 2 lists packaging procedures that apply to those poisonous liquids and solids for which exceptions under 49 CFR 173.153 are allowed. This includes 1,1,1-trichloroethane,

trichloroethylene, trichlorobenzene, PCB transformer oil, and many of the other poisonous materials commonly encountered.

### 3.6.1.3. CERCLA Reportable Quantities — DOT Class 9

Table 3-2 Column 3 lists packaging procedures for substances (liquids and solids) where the waste material is not otherwise classified as a DOT Hazardous Material because of hazardous properties *and* for which the entry in Column 8a of 49 CFR 172.101 Table is 155. For the shipment of larger quantities of EPA hazardous waste and DOT Class 9 hazardous substances where the quantity of material in each container *exceeds* the CERCLA RQ and no other DOT Hazardous Material classification applies, the following packaging requirements apply:

- Label each container with a separate container number
- Seal each drum or pail with a Security Seal
- Prepare one COC record for each group of containers that is being shipped at the same time to the same destination. List the container numbers on the COC record.

These shipments may include EPA Hazardous Waste in 5-gallon cans and 55-gallon drums. Most DOT containers are approved. The list of approved containers for packing Groups II and III Class 9 Hazardous Substances are listed in §173.203 for liquids and §173.213 for solids. These lists include steel, aluminum, plastic and fiber drums (solids only). Quantity limitations are shown in 49 CFR 172.101, Column 9.

**Table 3-1. Packaging by Common Carrier**

Instructions	By Common Carrier	
	Non-hazardous Samples	Hazardous Samples
Secure sample container lids with strapping tape.	1*	1*
Mark the level of material in each sample container with a grease pencil.	2	2
Place each container in a clear plastic resealable food bag so that the sample container label can be read.		3
Place about ½ inch of inorganic cushioning material such as vermiculite in the bottom of a metal can.		4
Place each container in a separate can and fill the remaining volume of the can with an inorganic cushioning material such as vermiculite (do not use plastic foam cushioning material as it could dissolve if the sample container were to leak).		5
Close the can using three clips to secure the lid.		6
Write the sample number on the can lid. Indicate “This Side Up” by drawing an arrow on the can.		7
Put about 1 inch of cushioning material (e.g., vermiculite or plastic foam) in the bottom of a watertight metal or equivalent strength plastic shipping container. If the container is a cooler, seal the drain plug on the inside of the cooler with tape. Also line the inside of the container with a plastic bag.	3	8
Wrap glass bottles and jars in plastic bubble wrap.	4	
Place cans in the container and fill the remaining volume of the shipping container with packing material. Add ice bags if required.		9
Place the sample containers top-up in the shipping container. Arrange the sample containers so that glass containers are surrounded by plastic containers.	5	
Fill the void space around and on top of the sample containers with plastic bags filled with ice cubes or ice chips.	6	
Seal the COC record in a clear plastic resealable food bag and tape it securely to the inside of the shipping container lid.	7	10
Close and lock or latch the shipping container.	8	11

Instructions	By Common Carrier	
	Non-hazardous Samples	Hazardous Samples
If the shipping container used is a picnic cooler, use tape to seal the drain plug.	9	12
After acceptance by the shipper, tape the shipping container completely around with strapping tape at two locations. Secure the lid with tape. Do not cover any labels.		13
Place the laboratory address on the top of the shipping container.		14
For all hazardous shipments, complete shipper's hazardous material certification form.		15
Place a “This End Up” label on the lid and on all four sides of the shipping container.	10	16
Affix the signed and dated custody seals on the front right and back left of the shipping container. Cover the seals with wide, clear tape.	11	17

\*Numbers indicate the instructions that must be followed.

**Table 3-2. Packaging Not by Common Carrier**

Instructions	Flammable Liquid	Poison DOT Class 6.1	DOT Class 9
<p><b><i>Quantity limitations shipped by cargo aircraft</i></b> Gross weight of package:</p> <p>Total quantity of flammable liquid:</p> <p>Maximum sample container size:</p>	<p>66 pounds</p> <p>49 CFR 172.101 Table, Column 6b</p> <p>49 CFR 172.101 Table, Column 5 <i>or</i> The flash point of the liquid</p>	<p>66 pounds</p> <p><i>Liquids –</i> 4 liters (1 gallon) <i>Solids –</i> 5 kilograms (11 pounds)</p>	<p>66 pounds</p> <p><i>Liquids –</i> 4 liters (1 gallon) <i>Solids –</i> 5 kilograms (11 pounds)</p>
Check the caps of all sample containers to assure that they are secure. Tape caps.	1*	1*	1*
Place each sample container in an individual 6-mL plastic bag and secure with a twist tie. The sample identification tag should be positioned to enable it to be read through the bag.	2	2	2
Place sample containers in paint cans in a manner that will prevent bottle breakage.	3	<i>Liquids:</i> 3	
Place vermiculite in the paint can around the samples. The amount of vermiculite used should be sufficient to absorb the sample if a sample container should break.	4		
Secure the lid to the paint can with can clips and label the outside of the can with the sample ID numbers and quantity.	5		
Wrap bubble wrap around each glass sample container and fix with tape.		<i>Solids:</i> 4	3
Package the paint cans in DOT boxes or cooler. Use additional packaging to secure cans.	6		
Seal the drain plug with tape on the inside and outside of the cooler and line		5	4

Instructions	Flammable Liquid	Poison DOT Class 6.1	DOT Class 9
the cooler with a plastic bag. Place the canned or bagged sample containers in the cooler. If plastic bottles are being used, alternate them with any glass container.			
Fill any voids in the cooler with additional packing material.	7	6	5
Place ice contained in bags on top of all sample containers within the cooler. Use as much ice as space will allow.	8	7	6
Place the COC record in a clear plastic resealable food bag and tape to the inside of the cooler lid. Label the outside of the cooler as containing the COC record.	9	8	7
Seal the cooler lid with clear tape or strapping tape. Affix security seals.	10	9	8

\*Numbers indicate the instructions that must be followed.

### 3.6.2. Marking and Labeling

All samples *must be labeled* to prevent misidentification and should include the following information:

- Sample # or ID
- Date of collection
- Collector
- Analysis requested
- Preservative
- Sample location.

Sample labels must clearly link the sample to the field sheet or the COC record and must be written legibly and in permanent ink. In addition, all containers must be labeled and listed on the COC record.

---

**Note:** If a three-bottle set is used for VOAs, all three bottles must be labeled and listed on the COC record.

EPA TSCA regulations [40 CFR 761.40(e)] require that a PCB label be put on all containers whose surfaces are in direct contact with material that is over 50 parts per million (ppm) PCBs.

This requirement applies to sample containers as well as pails, drums, and other containers that are in direct contact with the PCB material. The labeling requirement does not apply to containers in which PCB sample containers are shipped.

Although the sample containers must be individually labeled, this requirement is not affected by the quantity of sample or whether the sample is classified as hazardous under RCRA or DOT regulations. For DOT Class 9 and EPA Hazardous Waste the following labeling requirements apply:

- If EPA Hazardous Waste Manifest is required:
  - Hazardous waste
    - liquid, NOS, NA3082
    - solid, NOS, NA3077
- If EPA Hazardous Waste Manifest *is not* required:
  - Environmentally hazardous substances
    - liquid, NOS, UN3082
    - solid, NOS, UN3077

OSHA's Hazard Communication Standard requires all containers of hazardous materials coming in or out of a workplace to be labeled with the contents, appropriate hazard warnings, and the name and address of the manufacturer. OSHA does not specify a standard labeling method, but some commonly used ones are provided by National Fire Protection Association (NFPA), Hazardous Materials Identification System (HMIS), ANSI, and DOT.

### 3.6.3. Shipping Papers

Ship high hazard samples via overnight courier following the courier's documentation requirements. A special airbill must be completed for each shipment. An EPA manifest must be prepared if the shipping container contains hazardous waste *unless* the samples are exempt. The Hazardous Waste Manifest must bear the handwritten signatures of the generator, transporter, and designated facility. A copy of the manifest must be kept for 3 years by the shipper. The shipping papers must contain the name, address, and handwritten signature of the shipper.

The shipping papers (and Hazardous Waste Manifest if used) must contain a 24-hour emergency response telephone number. This phone number must be monitored at all times while the hazardous material is in transportation, including storage incidental to transportation. The phone must be monitored by a person who is either knowledgeable of the hazards and characteristics of the hazardous material being shipped and has comprehensive emergency response and incident mitigation information for that material, or who has immediate access to a person who possesses such knowledge and information. The emergency response phone number must be entered on the shipping paper immediately following the description of the hazardous material or entered once on a shipping paper if the number applies to all of the hazardous materials and is indicated for emergency response information.

### 3.7. QA/QC Protocol

QC is a normal part of good field and laboratory practice. QC includes all of the procedures ap-

plied to data collection and generation activities to achieve and maintain the level of pre-established data quality. The desired level of data quality should be based on the intended use of the data. Therefore, the QC protocol should include all technical controls (e.g., sampling and analytical methods, use of field blanks, field duplicate samples, inclusion of performance testing or reference samples, statistical analysis, etc.). The controls start with the regulatory requirements of the data acquisition project and carry through to the ultimate data reporting and completion of all of the documentation of the use of these controls.

QA refers to the procedures used by management to assure that the QC is what is required and that it is being adhered to at any point in the project. QA constitutes the overview and monitoring processes designed to ensure that the quality of the data generated meets the desired levels as established by management. These controls include establishing DQOs based on the intended use of the data, the institution of procedures for formalizing planning documents prior to the initiation of data collection activities, and the use of audits to identify problems in both QC and QA.

The QA/QC protocol is specified in the SAP for each job that involves field sampling. QA/QC requirements are based on the level of data quality required for the project, and may address specific regulatory requirements. The purpose of a QA/QC protocol is to ensure the following:

- The laboratory receives samples that accurately represent the conditions existing at the sample site
- The results of the analysis are traceable to the specific sample location
- Compliance requirements are met.

The methods used to attain this protocol include training of personnel, providing detailed procedures for preparation, collection, marking and handling, packaging, packing, transfer of samples, and validation and verification of the administrative process and sampling techniques.

### 3.7.1. Decontamination of Sampling Equipment

The SAP should address the extent of decontamination and specify the procedures to prevent sample contamination. Sampling may be performed using separate laboratory cleaned equipment for each sample location. Procedure effectiveness should be checked for each matrix by submitting equipment decontamination blank samples to the laboratory for analysis.

---

**Note:** For specific information regarding the decontamination of field equipment, refer to *ASTM D5088-02, Standard Practices for Decontamination of Field Equipment Used at Waste Sites*. This standard describes the decontamination process for field equipment used in the sampling of soils, soil gas, sludges, surface water, and groundwater at waste sites. According to this standard, these practices are applicable only at sites where chemical (organic and inorganic) wastes are a concern, *not* for radiological, mixed (chemical and radiological), or biohazard sites.

### 3.7.2. Sample Container Cleanliness Requirements

Sample containers are a possible source of sample contamination. The SAP should specify the level of QC for sample containers. Pre-cleaned containers meeting EPA CERCLA cleanliness endurance criteria are available from several suppliers. If these containers are used, the serial number and QA batch number of each one should be recorded in the FLB/FN or on the field form. A review of the cleanliness should be made to ensure all parameters are checked to be below the detection limit of the contaminants to be tested for compliance. Some SDWA and CWA parameters may require laboratory cleaned containers proven to be below the limit of detection for the method.

---

**Note:** In no case should an effort be made in the field to decontaminate a sample container. If a container becomes contaminated, it should be replaced, with a note to that effect recorded in the FLB/FN.

### 3.7.3. Sample Container Type and Size Requirements

The types and sizes of sample containers to be filled for each sample will depend on method requirements and on QC requirements of the SAP. General sample container requirements are shown in Appendix B for different matrices and



analytical parameters. Compliance with specific instructions in the SAP is mandatory. If specified sample containers are not available, permission must be obtained from the Program Manager in writing for the use of other sizes and types of sample containers.

#### **3.7.4. Sample Preservation and Storage Requirements**

Special preservation and storage requirements should be specified in the SAP to ensure that samples do not undergo chemical changes from the time they were collected until their analysis by the laboratory. General requirements are specified in Appendix B. The specific requirements of the SAP will govern.

The quality of the reagents, water and materials used for preservation should be verified to ensure these items do not invalidate the reported results. Chemicals used as preservatives may be traced by lot number and quality by maintaining a reagent record keeping system. The water and acid preservatives used for trip and field blanks may be checked prior to use in the field and lot controlled to ensure no contamination is present prior to the material leaving the laboratory.

#### **3.7.5. Sample Holding Time Limits**

Even with preservation and special storage procedures, the composition of samples can change over time. The holding time for samples is the time from collection to laboratory preparation or analysis. Holding time limits summarized in Appendix B are method and program requirements. Site-specific holding times specified in the SAP take precedence.

#### **3.7.6. Laboratory and Field Analytical Procedures**

Laboratory analytical procedures for each parameter are specified based on the compliance limits, permit limits and data needs stated in the SAP. The SAP or COC record indicates to the laboratory which sample containers are to be analyzed for what parameters and specifies the analytical methods. Based on the DQOs, field testing may require the same level of QC as laboratory testing, and the procedures specified in

the field sampling or test plan must be followed exactly. Any deviations from established test procedures must be entered in the FLB/FN or on the field form and the Program Manager must be informed immediately of sample numbers affected.

#### **3.7.7. QC Samples**

Field QC samples are prepared and analyzed to determine whether test samples have become accidentally contaminated, check on the repeatability of the method, and ensure the samples are representative of the site or matrix sampled. A number of different QC samples may be specified. Each of the QC samples checks for a potential problem that can affect data reliability. The recommended frequency for each type of QC sample is summarized in Appendix C.

##### **3.7.7.1. Test Sample**

The test sample consists of one or more sample containers filled with material collected at one sampling point within a stated time. Several sampling containers may be required if material collected for analysis for different parameters must be preserved differently or sent to different laboratories. For a specific test sample, all containers are designated by the same sample location number, but may have different sample container numbers or designations to indicate variations made to the samples.

##### **3.7.7.2. Field Duplicates and Split Samples**

Field duplicate samples are two separate samples taken from the same source and are used to determine data repeatability based on field sampling and laboratory analysis procedures. Field duplicate samples are as follows:

- Assigned different container numbers
- Specified in the FLB/FN or on the field form
- Distinguished from the test samples on the COC record or field records
- Often submitted blind as to designation so the laboratory data assures objectivity.

---

**Exception:** Each test sample collected for a specific organic analysis may consist of two or more containers filled with the same material; these may be given different

container numbers but are designated as the same sample on the COC record. Only one sample container will be analyzed; the other being saved as a backup in case the laboratory must repeat the extraction and/or analysis. Duplicate samples for analysis consist of sets of two containers, with each pair of containers being designated on the COC record.

Field duplicate samples may be submitted to one laboratory for analysis for the same parameters. The comparability of the results provides information on the repeatability of the field sampling and laboratory analysis procedures.

The containers may be submitted to different laboratories for identical analyses to obtain information on inter-laboratory repeatability of field sampling and laboratory analysis procedures. This is a split sample.

Sample heterogeneity may cause major problems with the representativeness of field duplicate or split samples of soil/sediment matrices. Proper sample homogenization in the field will significantly improve the repeatability of the field sampling procedure. (Gy P. 1993, *Sampling for Analytical Purposes*, Wiley, West Sussex. Pitard F. F. 1993, *Pierre Gy's Sampling Theory and Sampling Practice: Heterogeneity, Sample Correctness and Statistical Process Control*, Books Britain, London.)

Typically, both field duplicates and split samples will be collected at a rate of 10% of field samples or at a minimum of one, per analyte, matrix, and sampling technique. More duplicates and split samples may be collected depending on the data quality needs.

### 3.7.7.3. Equipment Decontamination Blanks

Equipment decontamination blanks, or rinsate blanks, provide information on the levels of cross-contamination resulting from field or laboratory sample preparation actions. These blanks are specified in the SAP and on field sampling forms, and are prepared in the field. An equipment decontamination blank is usually reagent or deionized water that is free of the analyte of interest and is transported to the site, opened in the field, and poured over or through the sample collection device, collected in a sample container,

and returned to the laboratory and analyzed. This serves as a check on sampling device cleanliness. For example:

- **Field Groundwater Equipment Decontamination Blank for Metals Analysis.** Handled by the bailer, use ASTM Type II water, or better. Filter, place in a sample container, and preserve using the same procedures as for the test and duplicate samples.
- **Soil Sampling Equipment Decontamination Blank for Semivolatile Organics.** Rinse the field equipment prior to its use and collect the rinsate for analysis.
- **PCB Wipe Sample Equipment Decontamination Blank.** Use a wipe pad to wipe the sampling template in the same way the pad is handled during the actual wipe sampling of a surface.

One equipment decontamination blank is collected for each type of equipment used during the day or sampling event. Equipment decontamination blanks are assigned container numbers from the same sequence as the test samples, and may not be distinguished from the test samples on the COC record. More blanks may be collected depending on the data quality needs.

### 3.7.7.4. Field Blanks

Field blanks are prepared and analyzed to check cleanliness of sample containers, environmental contamination, and purity of reagents or solvents used in the field. A sample container is filled with laboratory ASTM Type I or II water, preserved, shipped to the field with clean sample containers, opened in the field to exposure to ambient field air for a time compatible to field sampling process, and is closed and submitted for analysis using the same parameters as the test sample. The reported results will indicate the presence of contamination. Field blanks are most often used when measuring for volatile analytes.

### 3.7.7.5. Trip Blanks

A trip blank is used with VOA analysis of water. A blank may consist of two 40-milliliter VOA vials filled at the laboratory with laboratory ASTM Type I or II water, transported to the

sampling site and returned to the laboratory without being opened. This serves as a check on sample contamination during sample transport and shipping.

---

**Note:** The caps used on VOA vials have Teflon®-lined septa. The Teflon® side of the silicone septum should face the sample. Prior to closing a vial, make sure there is no soil particle or dirt on the sealing surface of the VOA vial to prevent leaks. If a high concentration of volatile chemicals is present in the air in a shipping container, these chemicals can pass through the septum and contaminate the sample.

A trip blank is included in each shipping container used to ship VOA water samples. One VOA trip blank (two vials) is submitted to the laboratory in each cooler or per sampling event. The frequency of collection for trip blanks is specified in the SAP and is based on the data quality needs. Trip blanks are assigned container numbers from the same sequence used for the test samples, and are not designated as blanks on the COC record.

#### **3.7.7.6. Matrix Spike (MS)/Matrix Spike Duplicate (MSD)**

Project or compliance QC procedures require that the laboratory spike a portion of the matrix with a predetermined quantity of analyte(s) prior to sample extraction/digestion and analysis. The frequency of performing an MS is dependent on the data quality needs and method requirements.

A spiked sample is processed and analyzed in the same manner as the sample. The result of the analysis of the spike compared with the non-spike sample indicates the ability of the test procedures to recover the analyte from the matrix, and provides a measure of the performance of the analytical method executed by the laboratory.

For an MSD, a second portion of the matrix is spiked, and the recovery of the MSD can be compared with the recovery of the MS.

Depending on the matrix and analysis, additional sample containers may be specified to provide enough material for this laboratory procedure. These sample containers are assigned container numbers from the same sequence as the test samples and are designated MS/MSD materials on the COC record.

The MS/MSD samples are commonly used in CERCLA testing, but are not commonly used in CWA or SDWA testing. MSs are routinely performed by the laboratory as part of its internal QC on randomly chosen samples. If MS data is required for SDWA or CWA reporting requirements, a request must be made to the laboratory to ensure the MS is performed and reported on the appropriate sample. The sample selected for MSs should have the same or similar matrix as the field samples' but without high levels of target analytes.

#### **3.7.8. Field Audits**

The SAP will specify who will conduct field audits, along with their frequency and procedures. QA/QC procedures of the sample collection effort must identify and determine the magnitude of error associated with the contamination introduced through the sample collection effort. Audits are perhaps the most effective tool to ensure that the sampling is done correctly. The two factors most likely to influence the magnitude of the sample collection error are collection methods and frequency of sampling.

In general, a field sampling audit provides an independent outside check on the following:

- **Field Records**
  - COC records
  - Sample container labels
  - FLBs or field forms
  - Personnel training records
- **Sampling Procedures**
  - Equipment
  - Sample containers
  - Accuracy of sample location descriptions
  - Comparability of field sampling techniques
  - Collection and preparation of QC samples
  - Sample preservation
  - Equipment decontamination
  - Contaminated waste storage and disposal

- Sample packing, storage, security, and transportation
- Shipping containers, including use of custody seals (if applicable).

### 3.8. Generic Sampling Equipment List

Equipment specific to each type of media is found at the end of the related chapters. The following is a generic sampling equipment list:

- Map of sampling location(s)
- Sampling SOP
- FLB or field form
- Pens
- Containers
- Preservatives
- Labels
- Markers
- Coolers
- Ice
- Packing material
- Packaging tape
- COC form
- Custody seals (if required)
- Decontamination storage containers, equipment, and materials
- Personal safety equipment, safety test equipment
- Field screening or testing equipment, standards, reagents, and SOP
- Testing field forms or logbooks
- Laboratory instructions (if different from custody form).

## ATTACHMENT B

### Analytical Laboratory Information

1. Certificate of Accreditation, ISO/IEC 17025:2017 and DoD ELAP, Certificate Number ADE-1451 (Eurofins)
2. ORELAP Approval to Perform Analyses on Environmental Samples in Air, Certificate Number CA300005-011 (Eurofins).
3. South Coast Air Quality Management District, Reference #03LA0606 (Atmospheric Analysis and Consulting)

SOP No.	SOP Title	Author Organization
6	EPA Method TO-14A/TO-15 Volatile Organic Compounds (Standard/Quad)	Eurofins
54	ASTM D1945 – Fixed Gases & C1-C6	Eurofins
A.5504.04	Standard Operating Procedure, Determination of Sulfur Compounds in Natural Gas and Gaseous Fuels by Gas Chromatography and Chemiluminescence 9/11/2018, Revision 5	Atmospheric
ST-1	Best Environmental Mobile Laboratory Certification Source Test Protocol, Former Fort Ord, Monterey, CA. Thermal Treatment Unit (TTU). June 4,2018	Best Environmental



# CERTIFICATE OF ACCREDITATION

## ANSI National Accreditation Board

11617 Coldwater Road, Fort Wayne, IN 46845 USA

This is to certify that

**Eurofins Air Toxics, LLC**

**180 Blue Ravine Road  
Folsom, CA 95630**

has been assessed by ANAB and meets the requirements of international standard

**ISO/IEC 17025:2017**

and the

**U.S. Department of Defense (DoD) Quality Systems Manual for  
Environmental Laboratories (DoD QSM V5.3)**

while demonstrating technical competence in the field of

**TESTING**

Refer to the accompanying Scope of Accreditation for information regarding the types of activities to which this accreditation applies

ADE-1451

Certificate Number

  
ANAB Approval

Certificate Valid Through: 04/27/2020  
Version No. 008 Issued: 07/18/2019



This laboratory is accredited in accordance with the recognized International Standard ISO/IEC 17025:2017. This accreditation demonstrates technical competence for a defined scope and the operation of a laboratory quality management system (refer to joint ISO-ILAC-IAF Communiqué dated April 2017).

**SCOPE OF ACCREDITATION TO ISO/IEC 17025:2017 AND U.S.  
DEPARTMENT OF DEFENSE (DOD) QUALITY SYSTEMS MANUAL  
FOR ENVIRONMENTAL LABORATORIES (DOD QSM V5.3)**

**Eurofins Air Toxics, LLC**

180 Blue Ravine Road  
Folsom, CA 95630  
Melanie Levesque  
(916) 605-3396

**TESTING**

Valid to: **April 27, 2020**

Certificate Number: **ADE-1451**

**Environmental**

<b>Air and Emissions</b>		
<b>Technology</b>	<b>Method</b>	<b>Analyte</b>
GC/FID/dual TCD	ASTM D1945	Acetylene
GC/FID/dual TCD	ASTM D1945	Carbon Dioxide
GC/FID/dual TCD	ASTM D1945	Carbon Monoxide
GC/FID/dual TCD	ASTM D1945	Ethane
GC/FID/dual TCD	ASTM D1945	Ethylene
GC/FID/dual TCD	ASTM D1945	Helium
GC/FID/dual TCD	ASTM D1945	Hydrogen
GC/FID/dual TCD	ASTM D1945	Isobutane
GC/FID/dual TCD	ASTM D1945	Isopentane
GC/FID/dual TCD	ASTM D1945	Methane
GC/FID/dual TCD	ASTM D1945	n-Butane
GC/FID/dual TCD	ASTM D1945	Neopentane
GC/FID/dual TCD	ASTM D1945	Nitrogen
GC/FID/dual TCD	ASTM D1945	n-Pentane



<b>Air and Emissions</b>		
<b>Technology</b>	<b>Method</b>	<b>Analyte</b>
GC/FID/dual TCD	ASTM D1945	Oxygen
GC/FID/dual TCD	ASTM D1945	Propane
GC/FID/dual TCD	ASTM D1946	Carbon Dioxide
GC/FID/dual TCD	ASTM D1946	Carbon Monoxide
GC/FID/dual TCD	ASTM D1946	Ethane
GC/FID/dual TCD	ASTM D1946	Ethylene
GC/FID/dual TCD	ASTM D1946	Helium
GC/FID/dual TCD	ASTM D1946	Hydrogen
GC/FID/dual TCD	ASTM D1946	Methane
GC/FID/dual TCD	ASTM D1946	Nitrogen
GC/FID/dual TCD	ASTM D1946	Oxygen
GC/FID/PID	TO-3	TPH(GRO)
GC/FID/PID	TO-3	TPH(JP4)
GC/MS	TO-15 (Full Scan/SIM)	1,1,1-Trichloroethane
GC/MS	TO-15 (Full Scan/SIM)	1,1,2,2-Tetrachloroethane
GC/MS	TO-15 (Full Scan/SIM)	1,1,2-Trichloroethane
GC/MS	TO-15 (Full Scan/SIM)	1,1-Dichloroethane
GC/MS	TO-15 (Full Scan/SIM)	1,1-Dichloroethene
GC/MS	TO-15 (Full Scan)	1,2,3-Trichlorobenzene
GC/MS	TO-15 (Full Scan/SIM)	1,2,3-Trichloropropane
GC/MS	TO-15 (Full Scan/SIM)	1,2,4-Trichlorobenzene
GC/MS	TO-15 (Full Scan/SIM)	1,2,4-Trimethylbenzene
GC/MS	TO-15 (Full Scan/SIM)	1,2-Dibromoethane (EDB)
GC/MS	TO-15 (Full Scan/SIM)	1,2-Dichlorobenzene
GC/MS	TO-15 (Full Scan/SIM)	1,2-Dichloroethane





Air and Emissions		
Technology	Method	Analyte
GC/MS	TO-15 (Full Scan/SIM)	1,2-Dichloropropane
GC/MS	TO-15 (Full Scan/SIM)	1,2-Dichlorotetrafluoroethane (Freon 114)
GC/MS	TO-15 (Full Scan/SIM)	1,3,5-Trimethylbenzene
GC/MS	TO-15 (Full Scan/SIM)	1,3-Butadiene
GC/MS	TO-15 (Full Scan/SIM)	1,3-Dichlorobenzene
GC/MS	TO-15 (Full Scan/SIM)	1,4-Dichlorobenzene
GC/MS	TO-15 (Full Scan/SIM)	1,4-Dioxane
GC/MS	TO-15 (Full Scan)	2,2,4-Trimethylpentane
GC/MS	TO-15 (Full Scan/SIM)	2-Butanone (MEK)
GC/MS	TO-15 (Full Scan)	2-Chlorotoluene
GC/MS	TO-15 (Full Scan/SIM)	2-Hexanone
GC/MS	TO-15 (Full Scan/SIM)	2-Propanol
GC/MS	TO-15 (Full Scan)	3-Chloropropene
GC/MS	TO-15 (Full Scan)	4-Isopropyltoluene (p-Cymene)
GC/MS	TO-15 (Full Scan/SIM)	4-Methyl-2-pentanone (MIBK)
GC/MS	TO-15 (Full Scan/SIM)	Acetone
GC/MS	TO-15 SIM	Acetonitrile
GC/MS	TO-15 (Full Scan/SIM)	Acrolein
GC/MS	TO-15 SIM	Acrylonitrile
GC/MS	TO-15 (Full Scan/SIM)	alpha-Chlorotoluene
GC/MS	TO-15 (Full Scan)	alpha-Methyl Styrene
GC/MS	TO-15 (Full Scan/SIM)	Benzene
GC/MS	TO-15 (Full Scan/SIM)	Bromodichloromethane
GC/MS	TO-15 (Full Scan/SIM)	Bromoform
GC/MS	TO-15 (Full Scan/SIM)	Bromomethane



Air and Emissions		
Technology	Method	Analyte
GC/MS	TO-15 (Full Scan)	Butane
GC/MS	TO-15 (Full Scan)	Butyl Benzene
GC/MS	TO-15 (Full Scan)	Carbon disulfide
GC/MS	TO-15 (Full Scan/SIM)	Carbon tetrachloride
GC/MS	TO-15 (Full Scan/SIM)	Chlorobenzene
GC/MS	TO-15 (Full Scan/SIM)	Chlorodibromomethane
GC/MS	TO-15 (Full Scan/SIM)	Chloroethane
GC/MS	TO-15 (Full Scan/SIM)	Chloroform
GC/MS	TO-15 (Full Scan/SIM)	Chloromethane
GC/MS	TO-15 (Full Scan/SIM)	cis-1,2-Dichloroethene
GC/MS	TO-15 (Full Scan/SIM)	cis-1,3-Dichloropropene
GC/MS	TO-15 (Full Scan/SIM)	Cyclohexane
GC/MS	TO-15 (Full Scan)	Cumene
GC/MS	TO-15 (Full Scan)	Dibromomethane
GC/MS	TO-15 (Full Scan/SIM)	Dichlorodifluoromethane (Freon 12)
GC/MS	TO-15 (Full Scan)	Ethanol
GC/MS	TO-15 (Full Scan/SIM)	Ethyl Acetate
GC/MS	TO-15 (Full Scan/SIM)	Ethylbenzene
GC/MS	TO-15 (Full Scan/SIM)	Hexachlorobutadiene
GC/MS	TO-15 (Full Scan/SIM)	Methylene Chloride
GC/MS	TO-15 (Full Scan/SIM)	m,p-Xylene
GC/MS	TO-15 (Full Scan/SIM)	Naphthalene
GC/MS	TO-15 (Full Scan)	n-Butanol (1-Butanol)
GC/MS	TO-15 (Full Scan/SIM)	n-Heptane
GC/MS	TO-15 (Full Scan/SIM)	n-Hexane



Air and Emissions		
Technology	Method	Analyte
GC/MS	TO-15 (Full Scan)	Nonane
GC/MS	TO-15 (Full Scan)	n-Pentane
GC/MS	TO-15 (Full Scan)	n-Propylbenzene
GC/MS	TO-15 (Full Scan)	Octane
GC/MS	TO-15 (Full Scan/SIM)	o-Xylene
GC/MS	TO-15 (Full Scan/SIM)	p-Ethyltoluene
GC/MS	TO-15 (Full Scan/SIM)	Propylene
GC/MS	TO-15 (Full Scan)	sec-Butylbenzene
GC/MS	TO-15 (Full Scan/SIM)	Styrene
GC/MS	TO-15 (Full Scan)	tert-Butyl Alcohol
GC/MS	TO-15 (Full Scan)	tert-Butyl Benzene
GC/MS	TO-15 (Full Scan/SIM)	tert-Butyl methyl ether (MTBE)
GC/MS	TO-15 (Full Scan/SIM)	Tetrachloroethylene
GC/MS	TO-15 (Full Scan/SIM)	Tetrahydrofuran
GC/MS	TO-15 (Full Scan/SIM)	Toluene
GC/MS	TO-15 (Full Scan/SIM)	trans-1,2-Dichloroethene
GC/MS	TO-15 (Full Scan/SIM)	trans-1,3-Dichloropropene
GC/MS	TO-15 (Full Scan/SIM)	Trichloroethene
GC/MS	TO-15 (Full Scan)/SIM	Trichlorofluoromethane (Freon 11)
GC/MS	TO-15 (Full Scan)/SIM	Trichlorotrifluoroethane (Freon 113)
GC/MS	TO-15 (Full Scan/SIM)	Vinyl Acetate
GC/MS	TO-15 (Full Scan)	Vinyl Bromide
GC/MS	TO-15 (Full Scan/SIM)	Vinyl chloride
GC/MS	TO-17 (WMS/RAD130)	1,1,1-Trichloroethane
GC/MS	TO-17 (WMS/RAD130)	1,1,2,2-Tetrachloroethane



Air and Emissions		
Technology	Method	Analyte
GC/MS	TO-17 (WMS/RAD130)	1,1,2-Trichloroethane
GC/MS	TO-17 (WMS/RAD130)	1,1-Dichloroethane
GC/MS	TO-17 (WMS/RAD130)	1,1-Dichloroethene
GC/MS	TO-17 (WMS/RAD130)	1,2,4-Trimethylbenzene
GC/MS	TO-17 (WMS/RAD130)	1,2-Dichlorobenzene
GC/MS	TO-17 (WMS/RAD130)	1,2-Dichloroethane
GC/MS	TO-17 (WMS/RAD130)	1,3,5-Trimethylbenzene
GC/MS	TO-17 (WMS/RAD130)	1,3-Dichlorobenzene
GC/MS	TO-17 (WMS/RAD130)	1,4-Dichlorobenzene
GC/MS	TO-17 (WMS/RAD130)	2-Butanone (MEK)
GC/MS	TO-17 (WMS/RAD130)	4-Methyl-2-pentanone (MIBK)
GC/MS	TO-17 (WMS/RAD130)	Benzene
GC/MS	TO-17 (WMS/RAD130)	Carbon tetrachloride
GC/MS	TO-17 (WMS/RAD130)	Chlorobenzene
GC/MS	TO-17 (WMS/RAD130)	Chloroform
GC/MS	TO-17 (WMS/RAD130)	cis-1,2-Dichloroethene
GC/MS	TO-17 (WMS/RAD130)	Cyclohexane
GC/MS	TO-17 (WMS/RAD130)	Ethanol
GC/MS	TO-17 (WMS/RAD130)	Ethyl Acetate
GC/MS	TO-17 (WMS/RAD130)	Ethylbenzene
GC/MS	TO-17 (WMS/RAD130)	m,p-Xylene
GC/MS	TO-17 (WMS/RAD130)	Naphthalene
GC/MS	TO-17 (WMS/RAD130)	n-Heptane
GC/MS	TO-17 (WMS/RAD130)	n-Hexane
GC/MS	TO-17 (WMS/RAD130)	o-Xylene



Air and Emissions		
Technology	Method	Analyte
GC/MS	TO-17 (WMS/RAD130)	Propylbenzene
GC/MS	TO-17 (WMS/RAD130)	Styrene
GC/MS	TO-17 (WMS/RAD130)	tert-Butyl methyl ether (MTBE)
GC/MS	TO-17 (WMS/RAD130)	Tetrachloroethylene
GC/MS	TO-17 (WMS/RAD130)	Toluene
GC/MS	TO-17 (WMS/RAD130)	trans-1,2-Dichloroethene
GC/MS	TO-17 (WMS/RAD130)	Trichloroethene
GC/MS	TO-17 (WMS)	Vinyl chloride

Note:

1. This scope is formatted as part of a single document including Certificate of Accreditation No. ADE-1451.



---

Vice President

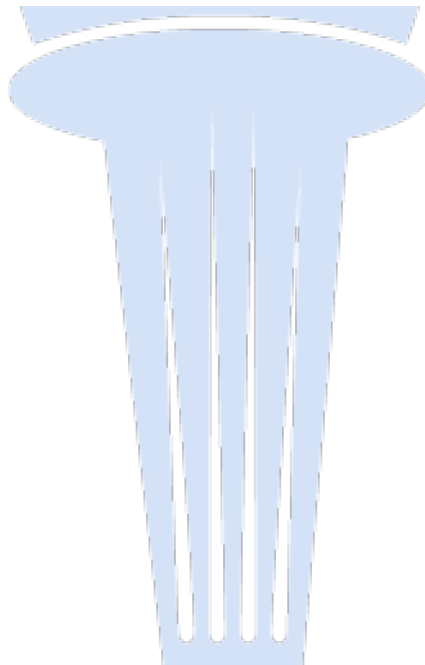



# OREGON

## Environmental Laboratory Accreditation Program

### ORELAP Fields of Accreditation

ORELAP ID: CA300005

EPA CODE: CA00933

Certificate: CA300005 - 013



Eurofins Air Toxics, LLC

180 Blue Ravine Road, Ste. B

Folsom, CA 95630

Issue Date: 10/18/2019 Expiration Date: 10/17/2020

As of 10/18/2019 this list supersedes all previous lists for this certificate number.

MATRIX	Reference	Code	Analyte	Code	Description
--------	-----------	------	---------	------	-------------

### Air

ASTM D1945 03		30024443	Natural Gas by Gas Chromatography		
	4938	2-Methylbutane (Isopentane)			
	4942	2-methylpropane (Isobutane)			
	4323	Acetylene			
	3755	Carbon dioxide			
	3780	Carbon monoxide			
	4747	Ethane			
	4752	Ethene			
	1767	Helium			
	1772	Hydrogen			
	4926	Methane			
	3853	Natural Gas			
	5007	n-Butane			
	9511	Neopentane			
	1843	Nitrogen			
	5028	n-Pentane			
	5029	n-Propane			
	3895	Oxygen			
ASTM D1946- 90		30024465	Reformed Gas by Gas Chromatography		
	3755	Carbon dioxide			
	3780	Carbon monoxide			
	4747	Ethane			
	4752	Ethene			
	1767	Helium			
	1772	Hydrogen			
	4926	Methane			
	1843	Nitrogen			
	3895	Oxygen			
EPA 325B 2013		10277437	Sorbent Tubes Coupled with Thermal Desorption and GC/MS		
	9318	1,3-Butadiene			
	4375	Benzene			
	4765	Ethylbenzene			
	5240	m+p-xylene			
	5250	o-Xylene			
	5100	Styrene			
	5140	Toluene			
	5170	Trichloroethene (Trichloroethylene)			



# OREGON

## Environmental Laboratory Accreditation Program

### ORELAP Fields of Accreditation

ORELAP ID: CA300005

EPA CODE: CA00933

Certificate: CA300005 - 013



Eurofins Air Toxics, LLC

180 Blue Ravine Road, Ste. B

Folsom, CA 95630

Issue Date: 10/18/2019 Expiration Date: 10/17/2020

**As of 10/18/2019 this list supersedes all previous lists for this certificate number.**

Air	EPA TO-12	10248201	Non-Methane Organic Compounds by GC/FID
	3860		Non-methane organics
	EPA TO-13A	10248405	Polycyclic Aromatic Hydrocarbons in Ambient Air by GC/MS
	5795		2-Chloronaphthalene
	6385		2-Methylnaphthalene
	5500		Acenaphthene
	5505		Acenaphthylene
	5555		Anthracene
	5575		Benzo(a)anthracene
	5580		Benzo(a)pyrene
	5590		Benzo(g,h,i)perylene
	5600		Benzo(k)fluoranthene
	5585		Benzo[b]fluoranthene
	5855		Chrysene
	5895		Dibenz(a,h) anthracene
	6265		Fluoranthene
	6270		Fluorene
	6315		Indeno(1,2,3-cd) pyrene
	5005		Naphthalene
	6615		Phenanthrene
	6665		Pyrene
	EPA TO-13A SIM	10248449	Polycyclic Aromatic Hydrocarbons in Ambient Air by GC/MS SIM
	5795		2-Chloronaphthalene
	6385		2-Methylnaphthalene
	5500		Acenaphthene
	5505		Acenaphthylene
	5555		Anthracene
	5575		Benzo(a)anthracene
	5580		Benzo(a)pyrene
	5590		Benzo(g,h,i)perylene
	5600		Benzo(k)fluoranthene
	5585		Benzo[b]fluoranthene
	5855		Chrysene
	5895		Dibenz(a,h) anthracene
	6265		Fluoranthene
	6270		Fluorene
	6315		Indeno(1,2,3-cd) pyrene
	5005		Naphthalene
	6615		Phenanthrene
	6665		Pyrene



# OREGON

## Environmental Laboratory Accreditation Program

### ORELAP Fields of Accreditation

ORELAP ID: CA300005

EPA CODE: CA00933

Certificate: CA300005 - 013



Eurofins Air Toxics, LLC

180 Blue Ravine Road, Ste. B

Folsom, CA 95630

Issue Date: 10/18/2019 Expiration Date: 10/17/2020

**As of 10/18/2019 this list supersedes all previous lists for this certificate number.**

Air	EPA TO-14A	10248609	Volatile Organic Compounds with SUMMA canister and GC/MS
5160	1,1,1-Trichloroethane		
5110	1,1,2,2-Tetrachloroethane		
5195	1,1,2-Trichloro-1,2,2-trifluoroethane (Freon 113)		
5165	1,1,2-Trichloroethane		
4630	1,1-Dichloroethane		
4640	1,1-Dichloroethylene		
5155	1,2,4-Trichlorobenzene		
5210	1,2,4-Trimethylbenzene		
4585	1,2-Dibromoethane (EDB, Ethylene dibromide)		
4695	1,2-Dichloro-1,1,2,2-tetrafluoroethane (Freon-114)		
4610	1,2-Dichlorobenzene		
4635	1,2-Dichloroethane (Ethylene dichloride)		
4655	1,2-Dichloropropane		
5215	1,3,5-Trimethylbenzene		
9318	1,3-Butadiene		
4615	1,3-Dichlorobenzene		
4620	1,4-Dichlorobenzene		
4735	1,4-Dioxane (1,4- Diethyleneoxide)		
4836	1-Propene (Propylene)		
4410	2-Butanone (Methyl ethyl ketone, MEK)		
4860	2-Hexanone (MBK)		
4542	4-Ethyltoluene		
4995	4-Methyl-2-pentanone (MIBK)		
4315	Acetone		
4375	Benzene		
5635	Benzyl chloride		
4395	Bromodichloromethane		
4400	Bromoform		
4450	Carbon disulfide		
4455	Carbon tetrachloride		
4475	Chlorobenzene		
4575	Chlorodibromomethane		
4485	Chloroethane (Ethyl chloride)		
4505	Chloroform		
4705	cis & trans-1,2-Dichloroethene		
4680	cis-1,3-Dichloropropene		
4555	Cyclohexane		
4625	Dichlorodifluoromethane (Freon-12)		
4750	Ethanol		
4765	Ethylbenzene		





# OREGON

## Environmental Laboratory Accreditation Program



### ORELAP Fields of Accreditation

ORELAP ID: CA300005

EPA CODE: CA00933

Certificate: CA300005 - 013

Eurofins Air Toxics, LLC

180 Blue Ravine Road, Ste. B

Folsom, CA 95630

Issue Date: 10/18/2019 Expiration Date: 10/17/2020

**As of 10/18/2019 this list supersedes all previous lists for this certificate number.**

Air	EPA TO-14A	4835	Hexachlorobutadiene
		4895	Isopropyl alcohol (2-Propanol, Isopropanol)
		4900	Isopropylbenzene (Cumene)
		5240	m+p-xylene
		4950	Methyl bromide (Bromomethane)
		4960	Methyl chloride (Chloromethane)
		5000	Methyl tert-butyl ether (MTBE)
		4975	Methylene chloride (Dichloromethane)
		5005	Naphthalene
		4825	n-Heptane
		4855	n-Hexane
		5090	n-Propylbenzene
		5250	o-Xylene
		5100	Styrene
		5115	Tetrachloroethylene (Perchloroethylene)
		5120	Tetrahydrofuran (THF)
		5140	Toluene
		4685	trans-1,3-Dichloropropylene
		5170	Trichloroethene (Trichloroethylene)
		5175	Trichlorofluoromethane (Fluorotrichloromethane, Freon 11)
		5235	Vinyl chloride
		5260	Xylene (total)
	EPA TO-15	10248803	VOCs collected in Canisters by GC/MS
		5160	1,1,1-Trichloroethane
		5110	1,1,2,2-Tetrachloroethane
		5195	1,1,2-Trichloro-1,2,2-trifluoroethane (Freon 113)
		5165	1,1,2-Trichloroethane
		4630	1,1-Dichloroethane
		4640	1,1-Dichloroethylene
		5180	1,2,3-Trichloropropane
		5182	1,2,3-Trimethylbenzene
		5155	1,2,4-Trichlorobenzene
		5210	1,2,4-Trimethylbenzene
		4585	1,2-Dibromoethane (EDB, Ethylene dibromide)
		4695	1,2-Dichloro-1,1,2,2-tetrafluoroethane (Freon-114)
		4610	1,2-Dichlorobenzene
		4635	1,2-Dichloroethane (Ethylene dichloride)
		4655	1,2-Dichloropropane
		5215	1,3,5-Trimethylbenzene
		9318	1,3-Butadiene



# OREGON

## Environmental Laboratory Accreditation Program

### ORELAP Fields of Accreditation

ORELAP ID: CA300005

EPA CODE: CA00933

Certificate: CA300005 - 013



Eurofins Air Toxics, LLC

180 Blue Ravine Road, Ste. B

Folsom, CA 95630

Issue Date: 10/18/2019 Expiration Date: 10/17/2020

**As of 10/18/2019 this list supersedes all previous lists for this certificate number.**

Air	EPA TO-15	4615	1,3-Dichlorobenzene
		4676	1,3-Diethylbenzene
		4620	1,4-Dichlorobenzene
		4735	1,4-Dioxane (1,4- Diethyleneoxide)
		4917	1-Butene
		4833	1-Pentene
		4836	1-Propene (Propylene)
		5220	2,2,4-Trimethylpentane
		4666	2,2-Dimethylbutane
		4667	2,3,4-Trimethylpentane
		4669	2,3-Dimethylbutane
		4671	2,3-Dimethylpentane
		4672	2,4-Dimethylpentane
		4410	2-Butanone (Methyl ethyl ketone, MEK)
		4535	2-Chlorotoluene
		4538	2-Ethyltoluene
		4860	2-Hexanone (MBK)
		4934	2-Methyl-2-Butene
		4937	2-Methylbutadiene (Isoprene)
		4938	2-Methylbutane (Isopentane)
		4939	2-Methylheptane
		4946	2-Methylhexane
		4941	2-Methylpentane (Isohexane)
		4942	2-methylpropane (Isobutane)
		4531	3-Ethyltoluene (1-Methyl-3-ethylbenzene)
		4529	3-Methyl-1-Butene
		4532	3-Methylheptane
		4533	3-Methylhexane
		4534	3-Methylpentane
		4542	4-Ethyltoluene
		4910	4-Isopropyltoluene (p-Cymene)
		4913	4-Methyl-1-Pentene
		4995	4-Methyl-2-pentanone (MIBK)
		4300	Acetaldehyde
		4315	Acetone
		4320	Acetonitrile
		4323	Acetylene
		4325	Acrolein (Propenal)
		4340	Acrylonitrile
		4355	Allyl chloride (3-Chloropropene)
		4357	alpha-Methylstyrene
		4375	Benzene
		5635	Benzyl chloride



# OREGON

## Environmental Laboratory Accreditation Program

### ORELAP Fields of Accreditation

ORELAP ID: CA300005

EPA CODE: CA00933

Certificate: CA300005 - 013



Eurofins Air Toxics, LLC

180 Blue Ravine Road, Ste. B

Folsom, CA 95630

Issue Date: 10/18/2019 Expiration Date: 10/17/2020

**As of 10/18/2019 this list supersedes all previous lists for this certificate number.**

Air	EPA TO-15	4390	Bromochloromethane
		4395	Bromodichloromethane
		4400	Bromoform
		4450	Carbon disulfide
		4455	Carbon tetrachloride
		4475	Chlorobenzene
		4575	Chlorodibromomethane
		4577	Chlorodifluoromethane (Freon-22)
		4485	Chloroethane (Ethyl chloride)
		4505	Chloroform
		4525	Chloroprene (2-Chloro-1,3-butadiene)
		4705	cis & trans-1,2-Dichloroethene
		4680	cis-1,3-Dichloropropene
		4602	cis-2-Butene
		4604	cis-2-Hexene
		4603	cis-2-pentene
		4555	Cyclohexane
		4562	Cyclopentane
		4563	Cyclopentene
		4595	Dibromomethane (Methylene bromide)
		4625	Dichlorodifluoromethane (Freon-12)
		4627	Dichlorofluoromethane (Freon 21)
		4725	Diethyl ether
		4747	Ethane
		4750	Ethanol
		4752	Ethene
		4755	Ethyl acetate
		4765	Ethylbenzene
		4835	Hexachlorobutadiene
		4895	Isopropyl alcohol (2-Propanol, Isopropanol)
		4900	Isopropylbenzene (Cumene)
		5240	m+p-xylene
		4930	Methanol
		4950	Methyl bromide (Bromomethane)
		4960	Methyl chloride (Chloromethane)
		4990	Methyl methacrylate
		5000	Methyl tert-butyl ether (MTBE)
		4965	Methylcyclohexane
		4966	Methylcyclopentane
		4975	Methylene chloride (Dichloromethane)
		5005	Naphthalene
		5007	n-Butane
		4435	n-Butylbenzene



# OREGON

## Environmental Laboratory Accreditation Program



### ORELAP Fields of Accreditation

ORELAP ID: CA300005

Eurofins Air Toxics, LLC

EPA CODE: CA00933

180 Blue Ravine Road, Ste. B

Certificate: CA300005 - 013

Folsom, CA 95630

Issue Date: 10/18/2019 Expiration Date: 10/17/2020

**As of 10/18/2019 this list supersedes all previous lists for this certificate number.**

Air	EPA TO-15			
		5875	n-Decane	
		4825	n-Heptane	
		4855	n-Hexane	
		5026	n-Nonane	
		5027	n-Octane	
		5028	n-Pentane	
		5029	n-Propane	
		5090	n-Propylbenzene	
		6747	n-Undecane	
		5250	o-Xylene	
		5253	p-Diethylbenzene	
		4440	sec-Butylbenzene	
		5100	Styrene	
		4420	tert-Butyl alcohol	
		4445	tert-Butylbenzene	
		5115	Tetrachloroethylene (Perchloroethylene)	
		5120	Tetrahydrofuran (THF)	
		5140	Toluene	
		4685	trans-1,3-Dichloropropylene	
		4607	trans-2-Butene	
		4606	trans-2-Hexene	
		4608	trans-2-pentene	
		5170	Trichloroethene (Trichloroethylene)	
		5175	Trichlorofluoromethane (Fluorotrichloromethane, Freon 11)	
		5225	Vinyl acetate	
		5230	Vinyl bromide (Bromoethane)	
		5235	Vinyl chloride	
		5260	Xylene (total)	
	EPA TO-15			10248858
	GC/MS SIM			VOCs collected in Canisters by GC/MS SIM
		5160	1,1,1-Trichloroethane	
		5110	1,1,2,2-Tetrachloroethane	
		5185	1,1,2-Trichloro-1,2,2-trifluoroethane (Freon 113)	
		5165	1,1,2-Trichloroethane	
		4630	1,1-Dichloroethane	
		4640	1,1-Dichloroethylene	
		5180	1,2,3-Trichloropropane	
		5155	1,2,4-Trichlorobenzene	
		5210	1,2,4-Trimethylbenzene	
		4585	1,2-Dibromoethane (EDB, Ethylene dibromide)	
		4695	1,2-Dichloro-1,1,2,2-tetrafluoroethane (Freon-114)	



# OREGON

## Environmental Laboratory Accreditation Program

### ORELAP Fields of Accreditation

ORELAP ID: CA300005

EPA CODE: CA00933

Certificate: CA300005 - 013



Eurofins Air Toxics, LLC

180 Blue Ravine Road, Ste. B

Folsom, CA 95630

Issue Date: 10/18/2019 Expiration Date: 10/17/2020

**As of 10/18/2019 this list supersedes all previous lists for this certificate number.**

Air	EPA TO-15 GC/MS SIM	4610	1,2-Dichlorobenzene
		4635	1,2-Dichloroethane (Ethylene dichloride)
		4655	1,2-Dichloropropane
		5215	1,3,5-Trimethylbenzene
		9318	1,3-Butadiene
		4615	1,3-Dichlorobenzene
		4620	1,4-Dichlorobenzene
		4735	1,4-Dioxane (1,4- Diethyleneoxide)
		4836	1-Propene (Propylene)
		4410	2-Butanone (Methyl ethyl ketone, MEK)
		4860	2-Hexanone (MBK)
		4542	4-Ethyltoluene
		4995	4-Methyl-2-pentanone (MIBK)
		4315	Acetone
		4320	Acetonitrile
		4325	Acrolein (Propenal)
		4340	Acrylonitrile
		4375	Benzene
		5635	Benzyl chloride
		4395	Bromodichloromethane
		4400	Bromoform
		4455	Carbon tetrachloride
		4475	Chlorobenzene
		4575	Chlorodibromomethane
		4485	Chloroethane (Ethyl chloride)
		4505	Chloroform
		4645	cis-1,2-Dichloroethylene
		4680	cis-1,3-Dichloropropene
		4555	Cyclohexane
		4625	Dichlorodifluoromethane (Freon-12)
		4755	Ethyl acetate
		4765	Ethylbenzene
		4835	Hexachlorobutadiene
		4895	Isopropyl alcohol (2-Propanol, Isopropanol)
		5240	m+p-xylene
		4950	Methyl bromide (Bromomethane)
		4960	Methyl chloride (Chloromethane)
		5000	Methyl tert-butyl ether (MTBE)
		4975	Methylene chloride (Dichloromethane)
		5005	Naphthalene
		4825	n-Heptane
		4855	n-Hexane
		5250	o-Xylene



# OREGON

## Environmental Laboratory Accreditation Program



### ORELAP Fields of Accreditation

ORELAP ID: CA300005

Eurofins Air Toxics, LLC

EPA CODE: CA00933

180 Blue Ravine Road, Ste. B

Certificate: CA300005 - 013

Folsom, CA 95630

Issue Date: 10/18/2019 Expiration Date: 10/17/2020

**As of 10/18/2019 this list supersedes all previous lists for this certificate number.**

Air	EPA TO-15 GC/MS SIM	5100 Styrene	
		5115 Tetrachloroethylene (Perchloroethylene)	
		5120 Tetrahydrofuran (THF)	
		5140 Toluene	
		4700 trans-1,2-Dichloroethylene	
		4685 trans-1,3-Dichloropropylene	
		5170 Trichloroethene (Trichloroethylene)	
		5175 Trichlorofluoromethane (Fluorotrichloromethane, Freon 11)	
		5225 Vinyl acetate	
		5235 Vinyl chloride	
	EPA TO-17		10312206 Determination of Volatile Organic Compounds in Ambient Air Using Active Sampling Onto Sorbent Tubes
		5160 1,1,1-Trichloroethane	
		5195 1,1,2-Trichloro-1,2,2-trifluoroethane (Freon 113)	
		5165 1,1,2-Trichloroethane	
		4630 1,1-Dichloroethane	
		4640 1,1-Dichloroethylene	
		5155 1,2,4-Trichlorobenzene	
		5210 1,2,4-Trimethylbenzene	
		4695 1,2-Dichloro-1,1,2,2-tetrafluoroethane (Freon-114)	
		4610 1,2-Dichlorobenzene	
		4635 1,2-Dichloroethane (Ethylene dichloride)	
		4655 1,2-Dichloropropane	
		5215 1,3,5-Trimethylbenzene	
		9318 1,3-Butadiene	
		4615 1,3-Dichlorobenzene	
		4620 1,4-Dichlorobenzene	
		4735 1,4-Dioxane (1,4-Diethyleneoxide)	
		6380 1-Methylnaphthalene	
		5220 2,2,4-Trimethylpentane	
		4410 2-Butanone (Methyl ethyl ketone, MEK)	
		4860 2-Hexanone (MBK)	
		4938 2-Methylbutane (Isopentane)	
		6385 2-Methylnaphthalene	
		4542 4-Ethyltoluene	
		4995 4-Methyl-2-pentanone (MIBK)	
		5500 Acenaphthene	
		5505 Acenaphthylene	
		5555 Anthracene	
		4375 Benzene	
		4450 Carbon disulfide	



# OREGON

## Environmental Laboratory Accreditation Program



### ORELAP Fields of Accreditation

ORELAP ID: CA300005

Eurofins Air Toxics, LLC

EPA CODE: CA00933

180 Blue Ravine Road, Ste. B

Certificate: CA300005 - 013

Folsom, CA 95630

Issue Date: 10/18/2019 Expiration Date: 10/17/2020

**As of 10/18/2019 this list supersedes all previous lists for this certificate number.**

Air	EPA TO-17		
		4455	Carbon tetrachloride
		4475	Chlorobenzene
		4485	Chloroethane (Ethyl chloride)
		4505	Chloroform
		4645	cis-1,2-Dichloroethylene
		4555	Cyclohexane
		4765	Ethylbenzene
		6265	Fluoranthene
		6270	Fluorene
		4835	Hexachlorobutadiene
		4895	Isopropyl alcohol (2-Propanol, Isopropanol)
		4900	Isopropylbenzene (Cumene)
		5240	m+p-xylene
		5000	Methyl tert-butyl ether (MTBE)
		4965	Methylcyclohexane
		4975	Methylene chloride (Dichloromethane)
		5005	Naphthalene
		4825	n-Heptane
		4855	n-Hexane
		5090	n-Propylbenzene
		5250	o-Xylene
		6615	Phenanthrene
		6665	Pyrene
		5100	Styrene
		5115	Tetrachloroethylene (Perchloroethylene)
		5140	Toluene
		4700	trans-1,2-Dichloroethylene
		5170	Trichloroethene (Trichloroethylene)
		5175	Trichlorofluoromethane (Fluorotrichloromethane, Freon 11)
		5235	Vinyl chloride
		5260	Xylene (total)
	EPA TO-17 Modified 2	10312217	Hydrocarbons in Ambient Air Using WMS Passive Sampling Tubes
		5160	1,1,1-Trichloroethane
		5110	1,1,2,2-Tetrachloroethane
		5165	1,1,2-Trichloroethane
		4630	1,1-Dichloroethane
		4640	1,1-Dichloroethylene
		5150	1,2,3-Trichlorobenzene
		5155	1,2,4-Trichlorobenzene
		5210	1,2,4-Trimethylbenzene
		4610	1,2-Dichlorobenzene



# OREGON

## Environmental Laboratory Accreditation Program



### ORELAP Fields of Accreditation

ORELAP ID: CA300005

Eurofins Air Toxics, LLC

EPA CODE: CA00933

180 Blue Ravine Road, Ste. B

Certificate: CA300005 - 013

Folsom, CA 95630

Issue Date: 10/18/2019 Expiration Date: 10/17/2020

**As of 10/18/2019 this list supersedes all previous lists for this certificate number.**

Air	EPA TO-17 Modified 2	4635	1,2-Dichloroethane (Ethylene dichloride)
		5215	1,3,5-Trimethylbenzene
		4615	1,3-Dichlorobenzene
		4620	1,4-Dichlorobenzene
		9546	1,4-Dithiane
		4410	2-Butanone (Methyl ethyl ketone, MEK)
		4995	4-Methyl-2-pentanone (MIBK)
		6698	alpha-Pinene
		4375	Benzene
		4455	Carbon tetrachloride
		4475	Chlorobenzene
		4505	Chloroform
		4645	cis-1,2-Dichloroethylene
		4555	Cyclohexane
		6208	d-Limonene
		4750	Ethanol
		4755	Ethyl acetate
		4765	Ethylbenzene
		6774	Halothane (2-Bromo-2-chloro-1,1,1-trifluoroethane)
		5240	m+p-xylene
		4960	Methyl chloride (Chloromethane)
		4990	Methyl methacrylate
		5000	Methyl tert-butyl ether (MTBE)
		5005	Naphthalene
		4825	n-Heptane
		4855	n-Hexane
		5090	n-Propylbenzene
		5250	o-Xylene
		5100	Styrene
		5115	Tetrachloroethylene (Perchloroethylene)
		5140	Toluene
		4700	trans-1,2-Dichloroethylene
		5170	Trichloroethene (Trichloroethylene)
		5235	Vinyl chloride
<hr/>			
EPA TO-3		10249000	Cryogenic Trapping
<hr/>			
		9408	Gasoline range organics (GRO)
<hr/>			
MADEP APH		90017188	Air-Phase Petroleum Hydrocarbons
<hr/>			
		9318	1,3-Butadiene
		3792	APH Aliphatics C5-C8
		3793	APH Aliphatics C9-C12
		3794	APH Aromatics C9-C10
		4375	Benzene





# OREGON

## Environmental Laboratory Accreditation Program



### ORELAP Fields of Accreditation

ORELAP ID: CA300005

EPA CODE: CA00933

Certificate: CA300005 - 013

Eurofins Air Toxics, LLC

180 Blue Ravine Road, Ste. B

Folsom, CA 95630

Issue Date: 10/18/2019 Expiration Date: 10/17/2020

**As of 10/18/2019 this list supersedes all previous lists for this certificate number.**

Air	MADEP APH				
		4765	Ethylbenzene		
		5240	m+p-xylene		
		5000	Methyl tert-butyl ether (MTBE)		
		5005	Naphthalene		
		5250	o-Xylene		
		5140	Toluene		
	Modified EPA TO-17 Passive RAD130 Tube 2			60032351	The Determination of Hydrocarbons in Air Via RAD130 RADIELLO Passive Sample Tubes
		5160	1,1,1-Trichloroethane		
		5110	1,1,1,2,2-Tetrachloroethane		
		5165	1,1,2-Trichloroethane		
		4630	1,1-Dichloroethane		
		4640	1,1-Dichloroethylene		
		5210	1,2,4-Trimethylbenzene		
		4610	1,2-Dichlorobenzene		
		4635	1,2-Dichloroethane (Ethylene dichloride)		
		5215	1,3,5-Trimethylbenzene		
		4615	1,3-Dichlorobenzene		
		4620	1,4-Dichlorobenzene		
		4410	2-Butanone (Methyl ethyl ketone, MEK)		
		4995	4-Methyl-2-pentanone (MIBK)		
		4375	Benzene		
		4455	Carbon tetrachloride		
		4475	Chlorobenzene		
		4505	Chloroform		
		4645	cis-1,2-Dichloroethylene		
		4555	Cyclohexane		
		4750	Ethanol		
		4755	Ethyl acetate		
		4765	Ethylbenzene		
		5240	m+p-xylene		
		5000	Methyl tert-butyl ether (MTBE)		
		5005	Naphthalene		
		4825	n-Heptane		
		4855	n-Hexane		
		5090	n-Propylbenzene		
		5250	o-Xylene		
		5100	Styrene		
		5115	Tetrachloroethylene (Perchloroethylene)		
		5140	Toluene		
		4700	trans-1,2-Dichloroethylene		
		5170	Trichloroethene (Trichloroethylene)		
		5235	Vinyl chloride		



# OREGON

## Environmental Laboratory Accreditation Program

**ORELAP Fields of Accreditation**

**ORELAP ID:** CA300005

**EPA CODE:** CA00933

**Certificate:** CA300005 - 013

Eurofins Air Toxics, LLC

180 Blue Ravine Road, Ste. B

Folsom, CA 95630

Issue Date: 10/18/2019 Expiration Date: 10/17/2020

**As of 10/18/2019 this list supersedes all previous lists for this certificate number.**





# South Coast Air Quality Management District

21865 Copley Drive, Diamond Bar, CA 91765-4178  
(909) 396-2000 • www.aqmd.gov

October 31, 2019

Dr. Sucha S. Parmar  
Atmospheric Analysis & Consulting  
1534 Eastman Ave., Suite A  
Ventura, CA 93003

Subject: LAP Approval Notice  
Reference # 03LA0606

Dear Dr. Parmar:

We completed our review of the renewal application you submitted for approval under the South Coast Air Quality Management District's Laboratory Approval Program (LAP). We are pleased to inform you that your firm is approved for the period beginning November 30, 2019, and ending November 30, 2020 for the following methods, subject to the requirements in the LAP Conditions For Approval Agreement:

Method 307-91  
Method 25.1 (Analysis)  
Method 25.3 (Analysis)

Thank you for participating in the LAP. Your cooperation helps us to achieve the goal of the LAP: to maintain high standards of quality in the sampling and analysis of source emissions. You may direct any questions or information to LAP Coordinator, Glenn Kasai. He may be reached by telephone at (909) 396-2271, or via e-mail at [gkasai@aqmd.gov](mailto:gkasai@aqmd.gov).

Sincerely,

A handwritten signature in black ink that reads "D. Sarkar".

Dipankar Sarkar  
Program Supervisor  
Source Test Engineering

GK/gk

191031 LapRenewal.doc

**STANDARD OPERATING PROCEDURE**

**DETERMINATION OF SULFUR COMPOUNDS IN NATURAL GAS AND GASEOUS FUELS BY GAS CHROMATOGRAPHY AND CHEMILUMINESCENCE**

**Method Number: ASTM D-5504-12**

**Matrix: Air**

**Sampling Media: Tedlar Bag or Passivated Canister**

**APPROVAL**

Date Issued: September 11, 2018

Prepared By: Zandra Baja

Laboratory Manager Approval \_\_\_\_\_

Laboratory Director Approval \_\_\_\_\_

**PREFACE**

This is a Standard Operating Procedure (SOP). The analyst must read, understand, and follow this procedure explicitly.

A copy of this SOP is permanently placed in the laboratory area where the work is performed. The Department Supervisor, Quality Assurance Coordinator, and President/General Manager of Operations each have a copy of this document. Any changes in the SOP need to be approved by the Quality Assurance Coordinator. Each page of such changes will be initialed, dated, and concurrently incorporated into all copies located in the laboratory.

**Revision History**

Revision #	Date	Author	Change Reference	Reason for Change
01	Unknown	Unknown	NA	Initial Release
02	05/29/2002	Vanessa Vera	All Pages	Periodic Review
03	01/04/2007	Marcus Hueppe	All Pages	Periodic Review
04	11/23/2009	Diana Ngo	All Pages	Periodic Review
05	09/11/2018	Zandra Baja	All Pages	Periodic Review

## 1. SCOPE AND APPLICATION

- 1.1. This method applies to the analysis of speciated volatile sulfur-containing compounds in high methane content gaseous fuels such as natural gas samples utilizing Gas Chromatography (GC) with Sulfur Chemiluminescence Detection (SCD). This method has also been applied to other types of gaseous samples including air, digester, landfill, and refinery fuel gas.
- 1.2. The method suggests a detection range of 0.01 to 1,000 mg/m<sup>3</sup> or 7 to 700,000 ppbv for a 1 mL sample. This SOP covers the low-level instrumentation system used to perform this methodology.
  - 1.2.1. A Limit of Detection (LOD) of 1.043 ppbv was achieved and a Practical Quantitation Limit (PQL) of 10.0 ppbv was determined for Hydrogen Sulfide (H<sub>2</sub>S). The Method Reporting Limit (MRL) was established at 3.28 ppbv for H<sub>2</sub>S.
  - 1.2.2. A Limit of Detection (LOD) of 1.079 ppbv was achieved and a Practical Quantitation Limit (PQL) of 10.0 ppbv was determined for Methyl Mercaptan (MeSH). The Method Reporting Limit (MRL) was established at 3.39 ppbv for MeSH.
  - 1.2.3. A Limit of Detection (LOD) of 1.328 ppbv was achieved and a Practical Quantitation Limit (PQL) of 10.0 ppbv was determined for Dimethyl Sulfide (DMS). The Method Reporting Limit (MRL) was established at 4.17 ppbv for DMS.
- 1.3. For LOD and PQL determinations refer to the QA/QC plan. Sample Reporting Limits (SRLs) are calculated as the product of the MRL and all sample dilution factors or concentration factors.

## 2. SUMMARY OF METHOD

Air samples are collected using either Tedlar bags or passivated (Silco or Silonite) Canisters. The individual sulfur components of a gas mixture are separated by GC and quantified using a SCD.

## 3. SAFETY

- 3.1. All samples should be treated as hazardous and precautions should be taken when handling. Personal Protective Equipment (PPE) such as safety glasses, gloves and lab coats should be worn at all times. Solvents and reagents should be handled under fume hoods and used only by trained personnel. Refer to the MSDS before use if there are any concerns as to the safe handling and disposal of material.
- 3.2. All solvents and materials used for preparation of standards or sample preparation are emptied into the Organic Waste Drum or other appropriate container. An outside contractor according with proper waste disposal procedures disposes of the organic waste drum contents. Procedures and waste manifest are in possession of the Technical Director.

## 4. SAMPLE HANDLING AND PRESERVATION

- 4.1. Air samples are collected and stored in Tedlar Bags, Silco or Silonite Canisters, non-reactive vessels,

or other approved sampling media.

- 4.2. A minimum of 20 mL of sample is needed to flush the loop.
- 4.3. Air samples should be stored in a cool, dry, dark place and must be analyzed within 24 hours of sampling time if collected in a Tedlar Bag, and within seven (7) days if collected in a Silco or Silonite Canister or other passivated container.

## 5. INTERFERENCES

- 5.1. Method interferences may be caused by contaminants in solvents, reagents, glassware and/or other sample processing hardware. All materials used must routinely demonstrate that they are free from interferences under the conditions of the analysis by running method blanks.
- 5.2. Syringes must be thoroughly cleaned and stored in a clean environment to help minimize interference problems.
- 5.3. The use of high purity gases, reagents, and solvents helps to minimize interference problems.
- 5.4. Canisters must be thoroughly cleaned and stored in a clean environment to help minimize interference problems. Refer to the Canister Cleaning SOP for further details.
- 5.5. Contamination by carryover can occur whenever high-level and low-level samples are sequentially analyzed. Whenever an unusually high sample is encountered, it should be followed by the analysis of a Method Blank to check for carryover.

## 6. INSTRUMENTATION AND EQUIPMENT

- 6.1. Gas Chromatograph with Sulfur Chemiluminescence Detection
  - 6.1.1. Agilent 6890N GC with Agilent 355 SCD (Low-Level System)
    - 6.1.1.1. Analytical Column – Agilent DB-Sulfur SCD 60 m x 0.320 mm x 4.2 µm
    - 6.1.1.2. Data Processing System – Agilent Chemstation
- 6.2. Digital Pressure Gauge – Ashcroft Model # 2074 ( $\pm 0.25\%$  Full scale)
- 6.3. Silco or Silonite Canisters – 6.0L, 1.4L, or other customer provided sizes
- 6.4. Graduated Gastight Syringes – various sizes of clean graduated gastight glass syringes equipped with three-way on/off valves.

## 7. STANDARDS AND REAGENTS

- 7.1. Standards – Stock standard solutions may be purchased as a certified solution or prepared from pure

materials. Purchased certified standards may be used until their certified expiration date. Prepared standards that are greater than 1,000 ppm are good for 1 year. Prepared standards that are less than or equal to 1,000 ppm are good for 6 months.

- 7.1.1. Each standard is logged into the AAC Stock Standard / Reagent Logbook and given a unique identification number (SS#####) upon receipt. All standard preparations are logged into the AAC Standard Preparation Logbook and given a unique identification number (PSmmddyy-##). This PS # is noted for all QC standards in the sequence.
- 7.1.2. Our current working standards are from Airgas: NIST certified 105.1 ppm ( $\pm 2\%$ ) standard of H<sub>2</sub>S with a balance gas of Air (Part Number: X02 A199C33A6767) and NIST certified 97.76 ppm ( $\pm 2\%$ ) standard of CS<sub>2</sub> with a balance gas of Air (Part Number: X02 A199C33A25G9)

## 8. PROCEDURE

### 8.1. Sample Preparation

- 8.1.1. Upon receipt, samples are assigned a unique laboratory ID number and stored either on the canister storage racks or in the bag storage area.
- 8.1.2. The Canister initial pressure is measured using the certified digital pressure gauge and then recorded on the canister tag, in the shipping and receiving logbook, and in the canister pressure log that goes with each project.
- 8.1.3. The Canister is then pressurized with UHP Helium using the certified digital pressure gauge to 900mmHgA and the final pressure is recorded on the canister tag, in the shipping and receiving logbook, and in the canister pressure log that goes with each project.

### 8.2. Sample Analysis

- 8.2.1. Check that all of the GC operating conditions are properly set and that the sample injection loop is in the load position.
- 8.2.2. For Ambient (Trace level) analysis
  - 8.2.2.1. For Canister samples
    - 8.2.2.1.1. Inject at least 20 mL (preferably 50-100 mL) of sample slowly through the sampling loop using a 1/8" Teflon line.
    - 8.2.2.1.2. A gastight syringe is used to make any necessary dilutions.
  - 8.2.2.2. For Tedlar Bag samples
    - 8.2.2.2.1. Withdraw ~50 to 100 mL of sample from the Tedlar bag using a gastight syringe.
    - 8.2.2.2.2. Inject at least 20 mL (preferably 50-100 mL) of sample slowly through

the sampling loop using a gastight syringe.

8.2.2.3. Allow the sample to equilibrate to atmospheric pressure and press the start button on the GC.

8.2.2.4. All samples must be analyzed in duplicate.

8.2.3. For all non-ambient high sulfur concentration samples including natural gas, refinery fuel gas, landfill gas, and digester gas, dilute the samples 5 to 100 times with UHP Helium before analyzing to prevent overloading the detector. Look up historical reports to determine what dilution levels to start with. Follow the same analysis procedures outlined in section 8.2.2 for ambient samples.

### 8.3. Standard Preparation and generation of calibration curve

8.3.1. The method recommends preparing a curve with at least three points but typically the curve includes the following points: 0, 10, 50, 500, and 2500 ppbv.

8.3.2. The calibration points are prepared by first diluting the 100 ppmv stock standards from section 7.1.2 to 2500 and 500 ppbv using UHP Helium in a Silonite Canister. The 10 and 50 ppbv calibration points are prepared by diluting the 500 ppbv standard with UHP Helium in a gastight glass syringe.

8.3.3. Each calibration point is analyzed in triplicate and the peak areas should be within 5% of their average. The average area for each point is used to produce a linear regression curve forced through zero.

8.3.4. SCDs are equimolar, therefore the response factor of each single sulfur compound should be within 5% of the H<sub>2</sub>S response factor. The H<sub>2</sub>S response factor is used for quantification of all single sulfur compounds and unidentified analytes. The CS<sub>2</sub> response factor is used for quantification of all sulfide and disulfide compounds. Identification is based on comparing retention times of authentic standards to those in the samples.

### 8.4. GC Preparation

8.4.1. GC 6890N with Agilent 355 SCD – “ASTM5504.M” Run Method

GC 6890N Instrument Control Parameters

#### Control Information

Sample Inlet = GC

Injection Source = sampling loop

#### Oven

Initial Temperature = 40°C

Initial Time = 12 min

Rate 1 = 10°C/min to 180°C

Final Temperature = 180°C

Final Temperature Hold = 5 min



Total GC Run Time = 31 min  
Maximum Temperature = 250°C  
Equilibration Time = 0.50 min

Inlet (Back)

Initial Temperature = 200°C (On)  
Carrier Gas Pressure = 41.27 psi (On)  
Gas Type = Helium  
Inlet Split Ratio = 6.0:1

Column

Model Number = Agilent G3903-63001  
Max Temperature = 250°C  
Nominal Length = 60 m  
Nominal Diameter = 0.320 mm  
Mode = constant flow  
Initial Flow = 7.5 mL/min  
Outlet Pressure = Ambient

Detector (Back)

Temperature = 200°C (On)

Signal 2

Data Rate = 50 Hz  
Save Data = On  
Zero = 0.0 (Off)  
Range = 0

Agilent 355 SCD

Hydrogen Pressure = 35 psi  
Oxygen Pressure = 3 psi  
He Makeup Pressure = 0 psi  
Ozone Pressure = ~4.5 psi  
Furnace Temperature = 900°C

8.5. Analysis Sequence

- 8.5.1. System Blank – For the first injection of the day on the instrument, and any time that sample carryover has occurred, the analyst must demonstrate, through the analysis of a system blank that there are no interferences from the analytical system. The system blank used in this method is UHP Helium.
- 8.5.2. Calibration Standards – Each calibration standard must be analyzed in triplicate with a minimum of three calibration points that bracket the anticipated analyte concentrations when a new calibration is required.
- 8.5.3. Continuing Calibration Verification (CCV) – Before analyzing any samples and at the end of each sequence a CCV should be analyzed to verify that the instrument's calibration is still

valid. The concentration of the standard used should be within the range of the samples and at least 10 times the detection limit. Generally, the CCV concentration is 500 ppbv. The opening CCV is analyzed in triplicate.

- 8.5.4. Method Blank (MB) – For each batch (up to 20 samples), a MB must be analyzed. This blank should go through all of the stages of sample preparation and measurements that the samples undergo. The MB used in this method is UHP Helium.
- 8.5.5. Matrix Spike (MS) and Matrix Spike Duplicate (MSD) – For each batch (up to 20 samples) an MS and MSD must be analyzed. The MS / MSD are prepared by the addition of a known amount of the standard to a sample extract. Generally, the MS and MSD concentrations are prepared with a 1:1 mixture of 500 ppbv H<sub>2</sub>S/CS<sub>2</sub> standard and a known volume of sample gas.
- 8.5.6. Sample Analysis – Every sample must be analyzed in duplicate. When a concentration of a compound within the sample falls out of linear range for the calibration curve, dilutions of the sample are made and reanalyzed. Each sample is analyzed and the concentration calculated. If the concentration of the duplicate run is outside of the range of the ±10% from the initial sample, then the sample must be reanalyzed until that condition is met. Enter the sample dilution factor ( $DF_E$ ) into the data processing software sequence.

## 9. QUALITY CONTROL

QC Performed	Frequency	Acceptance Criteria	Corrective Action
Calibration Curve	Recommended every month or whenever maintenance is performed	1 – Correlation Coefficient of a linear least-squares fit $R^2 \geq 0.990$ 2 – Max range $\leq 5\%$ for three consecutive trials 3 – Recovery of $100 \pm 5\%$ of theoretical value	1 - Rerun curve 2 - Prepare new standards and rerun curve
Continuing Calibration Verification (CCV)	After the curve; Before analyzing any samples; and At the end of each sequence	1 – Max range $\leq 5\%$ for three consecutive trials 2 – Recovery of $100 \pm 10\%$ of theoretical value	1 – Rerun check 2 – Prepare new standard and rerun 3 – Rerun calibration
Matrix Spike and Matrix Spike Duplicate (MS / MSD)	For each batch – up to 20 samples	1 – Recovery of $100 \pm 10\%$ of theoretical value 2 – RPD $< 10\%$	1 – Rerun check 2 – Prepare new standard and rerun 3 – Flag data
Field Sample Duplicates	Every sample is analyzed in duplicate	Within 10% of initial analysis	1 – Rerun check 2 – Prepare new sample and rerun 3 – Flag data

Method Blank	For each batch – up to 20 samples	< RL	1 – Rerun check 2 – Prepare new blank and rerun 3 – Perform blank subtraction for all samples included in batch
System Blank	Before and after the curve; Before processing any samples	< RL	1 – Rerun check 2 – Prepare new blank and rerun

- 9.1. The QC criteria outlined here is above and beyond what the method requires but is adhered to in this lab as good laboratory practice.
- 9.2. It is the responsibility of the analyst to perform the analysis according to this SOP and complete the documentation required for review.
- 9.3. It is the responsibility of all personnel who work with samples involving this method to note any anomalies or out-of-control events associated with the analysis of the samples. Any discrepancies must be noted and corrective action taken and documented.
- 9.4. Document all maintenance procedures in the instrument logbook assigned to each instrument.

**10. CALCULATIONS**

- 10.1. The data processing software calculates a Response Factor from the curve generated in Section 8.3 for each analyte concentration as follows:

$$RF = \frac{P_{ST} - P_0}{C_{ST}}$$

where:

$RF$  = Response factor for the analyte given as area counts per ppbv

$P_{ST}$  = Peak area counts for the analyte standard

$P_0$  = Calibration curve intercept; in most cases this is zero

$C_{ST}$  = Concentration of analyte in the calibration standard in units of ppbv

- 10.2. The data processing software calculates the analyte concentration in ppbv for each sample using the following equation:

$$C_{SAM} = \frac{P_{SAM} - P_0}{RF}$$

where :

$C_{SAM}$  = Concentration of analyte in the sample in units of ppbv

$P_{SAM}$  = Peak area counts for the analyte sample

- 10.3. For those samples that were diluted in Section 8.5.7 the data processing software calculates the analyte concentration using the following formula:

$$C_{SAM} = C_{SAM_{DIL}} * DF_E$$

where :

$C_{SAM_{DIL}}$  = Concentration of analyte in the diluted sample

$DF_E$  = Sample dilution factor used in Section 8.5.7

- 10.4. The canister dilution factor is calculated using the following formula:

$$DF_C = \frac{P_F}{P_I}$$

where:

$DF_C$  = Canister Dilution Factor

$P_F$  = Pressure after canister has been pressurized using UHP He (should be ~900mmHg)

$P_I$  = Return initial pressure upon receipt from the field.

- 10.5. Calculate the CCV recoveries as follows:

$$\%Rec_{CCV} = \left( \frac{C_{CCV}}{C_{TC}} \right) * 100$$

where:

$C_{CCV}$  = Measured concentration of the CCV

$C_{TC}$  = Theoretical concentration of the CCV

- 10.6. Calculate the Matrix Spike recoveries as follows:

$$\%Rec_{MS} = \left( \frac{C_{MS}}{C_{SAM} + C_{spike}} \right) * 100$$

where:

$C_{MS}$  = Measured concentration of the Matrix Spike in units of ppbv

- 10.7. Calculate the Relative Percent Difference (RPD) for the Matrix spike samples using the following formula:

$$RPD_{MS} = ABS \left[ \frac{C_{MSdup} - C_{MS}}{Average(C_{MSdup}, C_{MS})} \right] * 100$$

where:

$C_{MSdup}$  = Measured concentration of the Matrix Spike duplicate in units of ppbv

$ABS$  = Absolute Value

10.8. Calculate the Relative Percent Difference (RPD) for the duplicate samples using the following formula:

$$RPD_{SAM} = ABS \left[ \frac{C_{DUP} - C_{SAM}}{Average(C_{SAM}, C_{DUP})} \right] * 100$$

where:

$C_{DUP}$  = Duplicate sample concentration in units of ppbv

## 11. REPORTING FORMAT

- 11.1. The samples are reported as the total quantity of analyte (ppbv) in the sample.
- 11.2. Any samples with analyte values below the Sample Reporting Limit are reported as <SRL for the specific analyte. If other analytes are present they are reported as stated in section 11.1.

## 12. REFERENCES

ASTM D-5504-12 “Standard Test Method for Determination of Sulfur Compounds in Natural Gas and Gaseous Fuels by Gas Chromatography and Chemiluminescence”

**FIGURE 1 – TYPICAL ASTM D-5504 CCV CHROMATOGRAM**

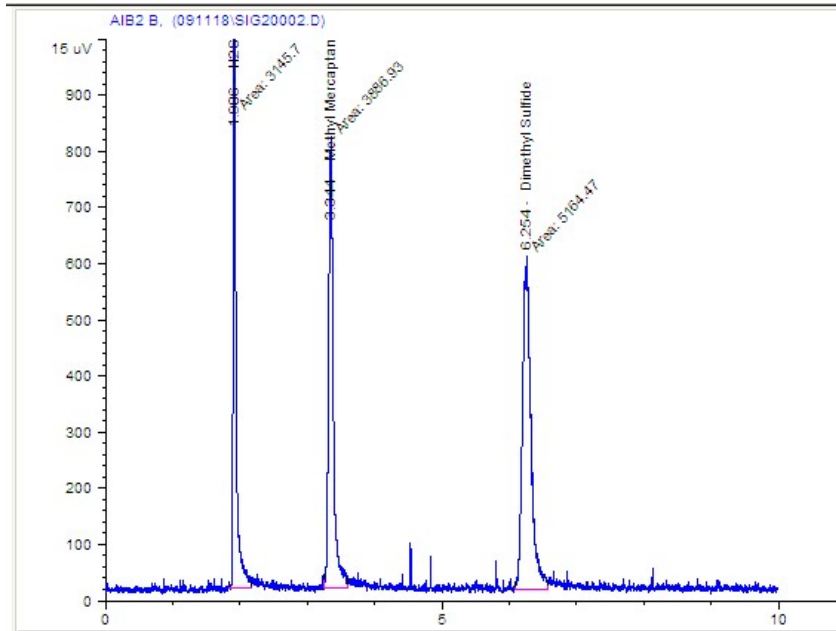

**FIGURE 2 – TYPICAL ASTM D-5504 BLANK CHROMATOGRAM**

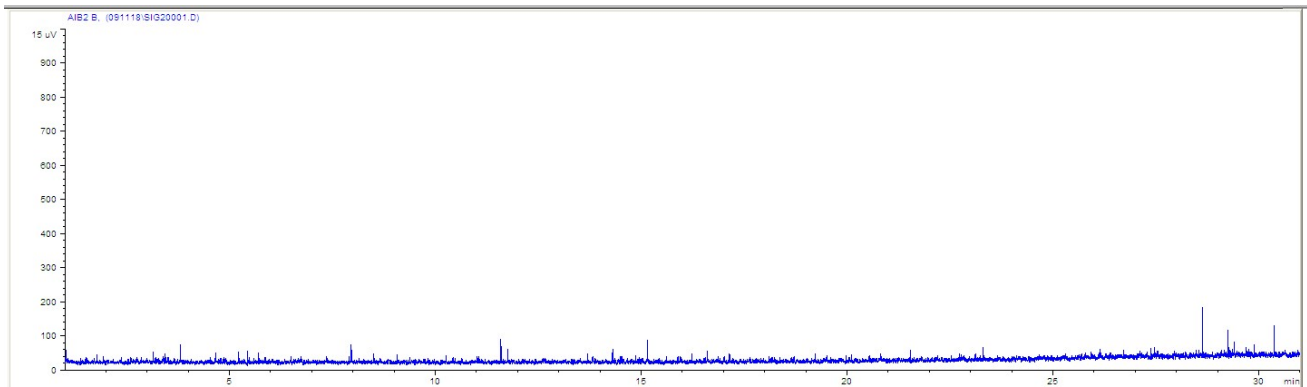

**ANALYTICAL METHODS**

**Section 2.0**

**Method: EPA Method TO-14A/TO-15 Volatile Organic Compounds (Standard/Quad)**

Eurofins Air Toxics SOP #6      Revision 37      Effective Date: March 24, 2017      Methods Manual Summary

**Description:** This method involves full scan gas chromatograph/mass spectrometer (GC/MS) analysis of whole air samples collected in evacuated stainless steel canisters. Samples are analyzed for volatile organic compounds (VOCs) using EPA Method TO-14A/TO-15 protocols. An aliquot of up to 0.5 liters of air is withdrawn from the canister utilizing a volumetric syringe, volumetric loop, or mass flow controller. This volume is loaded onto a hydrophobic multibed sorbent trap to remove water and carbon dioxide and to concentrate the vapor sample. The focused sample is then flash-heated to sweep adsorbed VOCs onto a secondary trap for further concentration and/or directly onto a GC/MS for separation and detection.

Eurofins Air Toxics maintains a suite of TO-14A/TO-15 methods, each optimized to efficiently meet the data objectives for a wide range of targeted concentration ranges. The methods, their reporting limits, and typical applications are summarized in the table below. This method summary describes TO-14A/TO-15 (Standard or Quad).

<b>Eurofins Air Toxics Method</b>	<b>Base Reporting Limits</b>	<b>Typical Application</b>
TO-14A/TO-15 (5&20)	5 – 20 ppbv	Soil gas and ppmv range vapor matrices
→ TO-14A/TO-15 (Standard or Quad)	0.5 – 5.0 ppbv	Ambient air, soil gas, and ppbv level vapor matrices
TO-15 (Extended)	0.2 – 1.5 ppbv	Ambient air and ppbv level vapor matrices
TO-14A/TO-15 (Low-level)	0.1 – 0.5 ppbv	Indoor and outdoor air
TO-14A/TO-15 SIM	0.003 – 0.5 ppbv	Indoor and outdoor air

Certain compounds are not included in Eurofins Air Toxics’ standard target analyte list. These compounds are communicated at the time of client proposal request. Unless otherwise directed, Eurofins Air Toxics reports these non-routine compounds with partial validation. Validation may include a 3-point calibration with the lowest concentration defining the reporting limit, no second source verification analyzed, and no method detection limit study performed unless previous arrangements have been made. In addition, stability of the non-standard compound during sample storage is not validated. Full validation may be available upon request.

***Eurofins Air Toxics takes no modifications of technical significance to Method TO-15 for the “Quad” configurations.*** Since Eurofins Air Toxics applies TO-15 methodology to all Summa canisters regardless of whether TO-14A or TO-15 is specified by the project, the laboratory performs a modified version of method TO-14A as detailed in Table 1. Please note that Methods TO-14A and TO-15 were validated for specially treated canisters. As such, the use of Tedlar bags for sample collection is outside the scope of the method and not recommended for ambient or indoor air samples. It is the responsibility of the data user to determine the usability of TO-14A and TO-15 results generated from Tedlar bags.

**Table 1. Summary of TO-14A Method Modifications**

Requirement	TO-14A	Eurofins Air Toxics Modifications
Sample Drying System	Nafion Drier	Multibed hydrophobic sorbent.
Blank acceptance criteria	≤ 0.2 ppbv	≤ RL
BFB ion abundance criteria	Ion abundance criteria listed in Table 4 of TO-14A	Follow abundance criteria listed in TO-15.
BFB absolute abundance criteria	Within 10% when comparing to the previous daily BFB	CCV internal standard area counts are compared to ICAL; corrective action when recovery is less than 60%.
Initial Calibration	≤ 30% RSD for listed 39 VOCs	≤ 30% RSD with 2 of Eurofins Air Toxics' 62 standard compounds allowed out to ≤ 40% RSD

The standard target analyte list, reporting limit (RL) also referred to as Limit of Quantitation, QC criteria, and QC summary can be found in Tables 2 through 5.

**Table 2. Method TO-14A/TO-15 Analyte List (Quad)**

Analyte	RL/LOQ (ppbv)	QC Acceptance Criteria			
		ICAL (%RSD)	CCV (%R)	ICV/LCS (%R)	Precision Limits (Max. RPD)
1,1,2,2-Tetrachloroethane	0.5	≤ 30%	70 – 130	70 – 130	± 25
1,1,2-Trichloroethane	0.5	≤ 30%	70 – 130	70 – 130	± 25
1,1-Dichloroethane	0.5	≤ 30%	70 – 130	70 – 130	± 25
1,1-Dichloroethene	0.5	≤ 30%	70 – 130	70 – 130	± 25
1,2,4-Trichlorobenzene	2.0	≤ 30%	70 – 130	70 – 130	± 25
1,2,4-Trimethylbenzene	0.5	≤ 30%	70 – 130	70 – 130	± 25
1,2-Dibromoethane (EDB)	0.5	≤ 30%	70 – 130	70 – 130	± 25
1,2-Dichlorobenzene	0.5	≤ 30%	70 – 130	70 – 130	± 25
1,2-Dichloroethane	0.5	≤ 30%	70 – 130	70 – 130	± 25
1,2-Dichloropropane	0.5	≤ 30%	70 – 130	70 – 130	± 25
1,3,5-Trimethylbenzene	0.5	≤ 30%	70 – 130	70 – 130	± 25
1,3-Dichlorobenzene	0.5	≤ 30%	70 – 130	70 – 130	± 25
1,4-Dichlorobenzene	0.5	≤ 30%	70 – 130	70 – 130	± 25
Benzene	0.5	≤ 30%	70 – 130	70 – 130	± 25
Bromomethane*	5.0	≤ 30%	70 – 130	70 – 130	± 25
Carbon Tetrachloride	0.5	≤ 30%	70 – 130	70 – 130	± 25
Chlorobenzene	0.5	≤ 30%	70 – 130	70 – 130	± 25



Analyte	RL/LOQ (ppbv)	QC Acceptance Criteria			
		ICAL (%RSD)	CCV (%R)	ICV/LCS (%R)	Precision Limits (Max. RPD)
Chloroethane	2.0	≤ 30%	70 – 130	70 – 130	± 25
Chloroform	0.5	≤ 30%	70 – 130	70 – 130	± 25
Chloromethane	5.0	≤ 30%	70 – 130	70 – 130	± 25
Chlorotoluene (Benzyl Chloride)	0.5	≤ 30%	70 – 130	70 – 130	± 25
cis-1,2-Dichloroethene	0.5	≤ 30%	70 – 130	70 – 130	± 25
cis-1,3-Dichloropropene	0.5	≤ 30%	70 – 130	70 – 130	± 25
Dichloromethane (Methylene Chloride)	5.0	≤ 30%	70 – 130	70 – 130	± 25
Ethylbenzene	0.5	≤ 30%	70 – 130	70 – 130	± 25
Freon 11 (Trichlorofluoromethane)	0.5	≤ 30%	70 – 130	70 – 130	± 25
Freon 113 (Trichlorotrifluoroethane)	0.5	≤ 30%	70 – 130	70 – 130	± 25
Freon 114	0.5	≤ 30%	70 – 130	70 – 130	± 25
Freon 12 (Dichlorodifluoromethane)	0.5	≤ 30%	70 – 130	70 – 130	± 25
Hexachlorobutadiene	2.0	≤ 30%	70 – 130	70 – 130	± 25
m,p-Xylene	0.5	≤ 30%	70 – 130	70 – 130	± 25
Methyl Chloroform (1,1,1-Trichloroethane)	0.5	≤ 30%	70 – 130	70 – 130	± 25
o-Xylene	0.5	≤ 30%	70 – 130	70 – 130	± 25
Styrene	0.5	≤ 30%	70 – 130	70 – 130	± 25
Tetrachloroethene	0.5	≤ 30%	70 – 130	70 – 130	± 25
Toluene	0.5	≤ 30%	70 – 130	70 – 130	± 25
trans-1,3-Dichloropropene	0.5	≤ 30%	70 – 130	70 – 130	± 25
Trichloroethene	0.5	≤ 30%	70 – 130	70 – 130	± 25
Vinyl Chloride	0.5	≤ 30%	70 – 130	70 – 130	± 25
1,3-Butadiene	0.5	≤ 30%	70 – 130	70 – 130	± 25
1,4-Dioxane	2.0	≤ 30%	70 – 130	70 – 130	± 25
2-Butanone (Methyl Ethyl Ketone)	2.0	≤ 30%	70 – 130	70 – 130	± 25
2-Hexanone	2.0	≤ 30%	70 – 130	70 – 130	± 25
4-Ethyltoluene	0.5	≤ 30%	70 – 130	70 – 130	± 25
4-Methyl-2-Pentanone (MIBK)	0.5	≤ 30%	70 – 130	70 – 130	± 25
Acetone	5.0	≤ 30%	70 – 130	70 – 130	± 25
Bromodichloromethane	0.5	≤ 30%	70 – 130	70 – 130	± 25
Bromoform	0.5	≤ 30%	70 – 130	70 – 130	± 25
Carbon Disulfide	2.0	≤ 30%	70 – 130	70 – 130	± 25

Analyte	RL/LOQ (ppbv)	QC Acceptance Criteria			
		ICAL (%RSD)	CCV (%R)	ICV/LCS (%R)	Precision Limits (Max. RPD)
Cyclohexane	0.5	≤ 30%	70 – 130	70 – 130	± 25
Dibromochloromethane	0.5	≤ 30%	70 – 130	70 – 130	± 25
Ethanol	2.0	≤ 30%	70 – 130	70 – 130	± 25
Heptane	0.5	≤ 30%	70 – 130	70 – 130	± 25
Hexane	0.5	≤ 30%	70 – 130	70 – 130	± 25
Isopropanol	2.0	≤ 30%	70 – 130	70 – 130	± 25
Methyl t-Butyl Ether (MTBE)	2.0	≤ 30%	70 – 130	70 – 130	± 25
Tetrahydrofuran	0.5	≤ 30%	70 – 130	70 – 130	± 25
trans-1,2-Dichloroethene	0.5	≤ 30%	70 – 130	70 – 130	± 25
2,2,4-Trimethylpentane	0.5	≤ 30%	70 – 130	70 – 130	± 25
Cumene	0.5	≤ 30%	70 – 130	70 – 130	± 25
Propylbenzene	0.5	≤ 30%	70 – 130	70 – 130	± 25
3-Chloroprene	2.0	≤ 30%	70 – 130	70 – 130	± 25
Naphthalene**	1.0	≤40%	60 – 140	60 – 140	± 25
TPH (Gasoline) ***	50	1-Point Calibration	N/A	ICV only; 60 – 140	± 25
NMOC (Hexane/Heptane)***	10	1-Point Calibration	N/A	NA	± 25

\*Bromomethane recovery can be variable due to moisture/sorbent interactions specifically on the 2-trap concentration system. Data may require qualifier flags.

\*\*Due to its low vapor pressure, Naphthalene may exceed TO-15 performance requirements. The wider QC limits reflect typical performance. Although Naphthalene is not on Eurofins Air Toxics “standard” TO-15 list, it is commonly requested and included in Table 2.

\*\*\*TPH and NMOC are not on Eurofins Air Toxics’ “standard” TO-15 list, but are included in Table 2 due to common requests.

**Table 3. Internal Standards**
**Table 4. Surrogates**

Analyte	Accuracy (% R)	Analyte	Accuracy (% R)
Bromochloromethane	60 – 140	1,2-Dichloroethane-d <sub>4</sub>	70 – 130
1,4-Difluorobenzene	60 – 140	Toluene-d <sub>8</sub>	70 – 130
Chlorobenzene-d <sub>5</sub>	60 – 140	4-Bromofluorobenzene	70 – 130

**Table 5. Summary of Calibration and QC Procedures for Methods TO-14A/TO-15**

QC Check	Minimum Frequency	Acceptance Criteria	Corrective Action
Tuning Criteria	Every 24 hours	TO-15 ion abundance criteria	Correct problem then repeat tune.
Minimum 5-Point Initial Calibration (ICAL)	Prior to sample analysis	% RSD $\leq$ 30 with 2 compounds allowed out to $\leq$ 40% RSD	Correct problem then repeat Initial Calibration curve.
Initial Calibration Verification and Laboratory Control Spike (ICV and LCS)	After each Initial Calibration curve, and daily prior to sample analysis	Recoveries for 85% of "Standard" compounds must be 70–130%. No recovery may be < 50%.  If specified by the client, in-house generated control limits may be used.	Check the system and reanalyze the standard. Re-prepare the standard if necessary to determine the source of error. Re-calibrate the instrument if the primary standard is found to be in error.
Initial Calibration Verification and Laboratory Control Spike (ICV and LCS) for Non-standard compounds	Per client request or specific project requirements only	Recoveries of compounds must be 60–140%. No recovery may be <50%.	Check the system and reanalyze the standard. Re-prepare the standard if necessary to determine the source of error. Re-calibrate the instrument if the primary standard is found to be in error.
Continuing Calibration Verification (CCV) for Standard compounds	At the start of each analytical clock after the tune check	70–130%	Compounds exceeding this criterion and associated data will be flagged and narrated with the exception of high bias associated with non-detects.  If more than two compounds from the standard list recover outside of 70–130% or > 10% of VOCs if short list is used (20 compounds or less), corrective action will be taken. If any compound exceeds 60–140%, samples are not analyzed unless data meets project needs. Check the system and reanalyze the standard. Re-prepare the standard if necessary. Re-calibrate the instrument if the criteria cannot be met.
Continuing Calibration Verification (CCV) for Non-standard Compounds	Per client request or specific project requirements only.	Recoveries of compounds must be 60–140%. No recovery may be <50%.	Check the system and reanalyze the standard. Re-prepare the standard if necessary to determine the source of error. Re-calibrate the instrument if the primary standard is found to be in error.

QC Check	Minimum Frequency	Acceptance Criteria	Corrective Action
Laboratory Blank	After analysis of standards and prior to sample analysis, or when contamination is present.	Results less than the laboratory reporting limit	Inspect the system and re-analyze the blank. "B"-flag data for common contaminants.
Internal Standard (IS)	As each standard, blank, and sample is being loaded	Retention time (RT) for blanks and samples must be within $\pm 0.33$ min of the RT in the CCV and within $\pm 40\%$ of the area counts of the daily CCV internal standards.	<b>For blanks:</b> Inspect the system and reanalyze the blank. <b>For samples:</b> Re-analyze the sample. If the ISs are within limits in the re-analysis, report the second analysis. If ISs are out-of-limits a second time, dilute the sample until ISs are within acceptance limits and narrate.
Surrogates	As each standard, blank, and sample is being loaded	70–130%  If specified by the client, in-house generated control limits may be used.	<b>For blanks:</b> Inspect the system and reanalyze the blank. <b>For samples:</b> Re-analyze the sample unless obvious matrix interference is documented. If the %Rs are within limits in the re-analysis, report the second analysis. If %Rs are out-of-limits a second time, report data from first analysis and narrate.
Laboratory Duplicates – Laboratory Control Spike Duplicates (LCSD)	One per analytical batch	RPD $\leq 25\%$	Narrate exceedances. If more than 5% of compound list is outside criteria or if compound has $>40\%$ RPD, investigate the cause and perform maintenance as required. If instrument maintenance is required, calibrate as needed.

**ANALYTICAL METHODS**

**Section 8.0**

**Method: ASTM D1945 – Fixed Gases & C1-C6**

Eurofins Air Toxics SOP #54    Revision 22    Effective Date: December 08, 2016    Methods Manual Summary

**Description:** This method involves gas chromatograph (GC) analysis of soil gas, landfill gas, ambient air, or stack gas collected in Summa™ canisters, Tedlar bags, or any vessel that has been demonstrated to be clean and leak free. Samples are analyzed for Methane and fixed gases and can be used to speciate individual light hydrocarbons up to C6. This method is also used to provide an estimation of the heating value of the gas by method ASTM D3588. Because the sample is withdrawn from the vessel by positive pressure, rigid containers are first filled to positive pressure using UHP Helium or Nitrogen. Samples are then analyzed using a GC equipped with a Flame Ionization Detector (FID) and a Thermal Conductivity Detector (TCD).

Certain compounds are not included in Eurofins Air Toxics’ standard target analyte list. These compounds are communicated at the time of client proposal request. Unless otherwise directed, the laboratory reports these non-standard compounds with partial validation. Validation includes a 5-point calibration with the lowest concentration defining the reporting limit (RL), no second source verification is analyzed, and no method detection limit study is performed unless previous arrangements have been made. In addition, stability of the non-standard compounds during sample storage is not validated. Full validation may be available upon request.

Since the protocols in the ASTM D1945 standard were designed for the analysis of natural gas, the laboratory has made modifications in order to apply the method to environmental samples covering a wide concentration range and to implement standard NELAP and EPA calibration criteria. The method modifications, standard target analyte list, RL, Quality Control (QC) criteria, and QC summary can be found in the following tables.

**Table 1. Summary of Method Modifications for ASTM D1945**

<b>Requirement</b>	<b>ASTM D1945</b>	<b>Eurofins Air Toxics Modifications</b>
Sample Injection Volume	0.50 mL to achieve Methane linearity.	1.0 mL
Calibration	A single point calibration is performed using a reference standard closely matching the composition of the unknown. Standard is analyzed such that 2 consecutive runs meet method repeatability requirements.	A minimum 5-point calibration curve is performed. Quantitation is based on the initial calibration response factor. A single run of a mid-level calibration standard is used to verify the initial calibration and may or may not resemble the composition of the associated samples.
Sample Analysis	Equilibrate samples to 20-50° F above source temperature at field sampling.	No heating of samples is performed.
Sample Calculation	Response factor is calculated using peak height for C5 and lighter compounds.	Peak areas are used for all target analytes to quantitate concentrations.
Normalization	Sum of original values should not differ from 100.0% by more than 1.0%.	Sum of original values may range between 85–115%; normalization of data not performed unless client requested.

**Table 2. ASTM Method D1945 Compound List and QC Limits**

Analyte	Reporting Limit (%)	QC Acceptance Criteria		
		ICAL (%RSD)	CCV/LCS/ICV (%R)	Precision* (%RPD)
Carbon Dioxide	0.01	≤ 15%	± 15%	≤ 25%
Carbon Monoxide	0.01	≤ 15%	± 15%	≤ 25%
Ethene	0.001	≤ 15%	± 15%	≤ 25%
Ethane	0.001	≤ 15%	± 15%	≤ 25%
Acetylene	0.001	≤ 15%	± 15%	≤ 25%
Isobutane	0.001	≤ 15%	± 15%	≤ 25%
Isopentane	0.001	≤ 15%	± 15%	≤ 25%
Methane	0.0001	≤ 15%	± 15%	≤ 25%
n-Butane	0.001	≤ 15%	± 15%	≤ 25%
Neopentane	0.001	≤ 15%	± 15%	≤ 25%
n-Pentane	0.001	≤ 15%	± 15%	≤ 25%
Nitrogen**	0.10	≤ 15%	± 15%	≤ 25%
NMOC (C6+)	0.01	≤ 15%	± 15%	≤ 25%
Oxygen	0.10	≤ 15%	± 15%	≤ 25%
Propane	0.001	≤ 15%	± 15%	≤ 25%
Hydrogen***	0.01	≤ 15%	± 15%	≤ 25%
Helium****	0.05	≤ 15%	± 15%	≤ 25%

\* For detections at > 5X the Reporting Limit.

\*\*For canisters that have been pressurized with Nitrogen, the amount of Nitrogen in the sample is determined by subtraction.

\*\*\*For canisters that have been pressurized with Helium, the Reporting Limit is 1.0%.

\*\*\*\*Included by special request only.

*Note: Results are reported in units of mol %. If required to report volume % or ppmV, a compressibility factor of 1 for all gases will be assumed. As a result, mol % is assumed to be equivalent to volume %. This assumption may result in a bias for highly compressible gases at high concentrations and pressures.*

**Table 3. Summary of Calibration and QC Procedures for Mod. ASTM Method D1945**

QC Check	Minimum Frequency	Acceptance Criteria	Corrective Action
Initial Calibration (ICAL)	Prior to sample analysis and annually	≤ 15% RSD	Correct problem, then repeat Initial Calibration.
Initial Calibration Verification and Laboratory Control Spike (ICV and LCS)	After each Initial Calibration and once per analytical batch.	85–115% Recovery If specified by the client, in-house generated control limits may be used.	Check the system and re-analyze the standard. Re-prepare the standard if necessary. If the primary standard is found to be in error, re-prepare the primary and calibrate the instrument.
Continuing Calibration Verification (CCV)	Daily prior to sample analysis, and can be used as an End Check.	± 15% Difference	Check the system and re-analyze the standard. Re-prepare the standard if necessary. Re-calibrate the instrument if the criteria cannot be met. If the closing CCV fails, the system is checked and the standard is re-analyzed. Re-prepare the standard if necessary. If the second analysis fails, identify and correct the problem, then re-analyze all samples since the last acceptable CCV.
Laboratory Blank	After analysis of standards and prior to sample analysis, or when contamination is present.	Results less than the laboratory Reporting Limit	Inspect the system and re-analyze the Laboratory Blank.
Laboratory Duplicates- Laboratory Control Spike Duplicate (LCSD)	One per analytical batch	RPD ≤ 25%	Narrate exceedances. Investigate the cause and perform maintenance as required and re-calibrate as needed.

State of California  
Air Resources Board  
Approved Independent Contractor

**Best Environmental**

This is to certify that the company listed above has been approved  
by the Air Resources Board to conduct compliance testing  
pursuant to California Code of Regulations, title 17, section 91207,  
until June 30, 2019, for the test method listed below:

Visible Emissions Evaluation

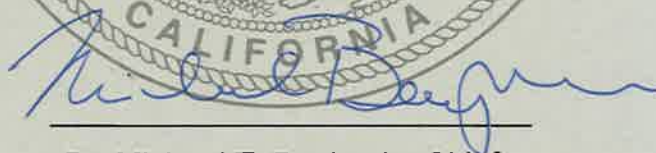

Dr. Michael T. Benjamin, Chief  
Monitoring and Laboratory Division



State of California  
**Air Resources Board**  
Approved Independent Contractor

**Best Environmental**

This is to certify that the company listed above has been approved by the Air Resources Board to conduct compliance testing pursuant to California Code of Regulations, title 17, section 91207, until June 30, 2019, for the test methods listed below:

ARB Source Test Methods:

1, 2, 3, 4, 5, 8, 11, 17

100 (CO, CO<sub>2</sub>, NO<sub>x</sub>, O<sub>3</sub>, SO<sub>2</sub>, THC)



Dr. Michael T. Benjamin, Chief  
Monitoring and Laboratory Division

State of California  
**Air Resources Board**  
Approved Independent Contractor

**Best Environmental**

This is to certify that the company listed above has been approved by the Air Resources Board to conduct compliance testing pursuant to California Code of Regulations, title 17, section 91207, until June 30, 2019, for the test methods listed below:

U.S. EPA Source Test Methods:  
15A, 201A, 202

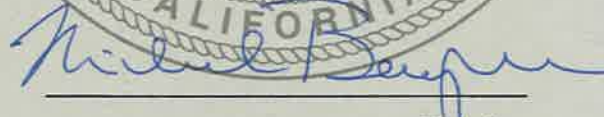

Dr. Michael T. Benjamin, Chief  
Monitoring and Laboratory Division

# **Source Test Protocol**

## **Former Fort Ord**

**Monterey, CA**

## **Thermal Treatment Unit (TTU)**

### **Prepared For:**

Ahtna Environmental Inc.

296 12<sup>th</sup> Street

Marina, CA 93933

Attn: Eric Schmidt

### **Prepared By:**

**BEST ENVIRONMENTAL**

339 Stealth Court

Livermore, CA 94551

Phone (925) 455-9474

Fax (925) 455-9479

Email: [bestair@best-enviro.com](mailto:bestair@best-enviro.com)

Date Issued: June 4, 2018

**SUMMARY INFORMATION****Source Test Information****General Information**

Source Owner: US Army

Source Location: Former Fort Ord  
Operable Unit 2 (OU2) Landfill  
Monterey Bay, CA

Contact: Eric Schmidt  
Phone: (831) 824-2308

Source Description: Thermal Treatment Unit

Test Parameters & Limits: NOx: 0.06 lbs/MMBtu  
CO: 0.4 lbs/MMBtu  
THC: 0.03 lbs/MMBtu  
NMOC: 98% DRE  
SOx: 2000 ppm  
Fuel Sulfur: 50 grs/100 scf

Source Testing Firm: **BEST ENVIRONMENTAL (BE)**  
339 Stealth Court  
Livermore, CA 94551  
Phone: (925) 455-9474  
Email: [bestair@best-enviro.com](mailto:bestair@best-enviro.com)  
Contact: Regan Best or Bobby Asfour

Proposed Testing Date(s): June 20, 2018  
Test Start Time: ~10:00 A.M.

Analytical Laboratories: **Eurofins/Air Toxics Ltd. (VOC's, Fixed Gases & Sulfur)**  
180 Blue Ravine Road  
Suite B  
Folsom, CA 95630  
Attn: Maria Barahas  
Phone: (800) 985-5955 x 1039

## 1.0 Introduction:

Annual source testing of the TTU is conducted to demonstrate that the TTU operates efficiently and meets air quality regulations for emissions. The TTU remedy is being performed under CERCLA (42 USC 9601 et seq.) as amended by SARA. As such, the MBUAPCD does not have jurisdiction and a permit for operating the TTU and exhaust stack is not required; however MBUAPCD Rule 207 and Rule 1000 are identified as applicable or relevant and appropriate requirements in the OU2 Landfills ROD (Army, 1994) and the substantive permit requirements were met during the reporting period. Meeting these objectives will require NO<sub>x</sub>, CO and THC/NMOC emission testing to be performed at the exhaust outlet of the TTU. The TTU fuel testing is required for NMOC, speciated VOCs, Total Sulfur as H<sub>2</sub>S & composition (including fixed gases & BTU/HHV).

## 2.0 Emission Source Information:

Ahtna Environmental (Ahtna) operates one TTU at the former Fort Ord Landfill. The TTU is used as a control device for removing the landfill gas created by the underground solid waste. The TTU stack will be equipped with proper sampling ports that meet and/or exceed the minimum location criteria of 2 stack diameters downstream from the burners and 0.5 diameters upstream from the stack exit. The sample ports will be accessed using a 40-foot boom-lift.

The TTU inlet gases will be accessed with a sample tap located downstream of the flame arrestor.

The flare will be operated at a flow rate of ~95 SCFM and an operating set point of ~1,650 deg-F during the testing. The quality of the landfill gas is ~36% (by volume) methane.

Description	Limits
Thermal Treatment Unit	NO <sub>x</sub> 0.06 lbs/MMBtu, CO 0.4 lbs/MMBtu, SO <sub>2</sub> 2000 ppmv, Inlet total sulfur 50 grains/100scf, THC 0.03 lbs/MMBtu & DRE ≥98%

### 3.0 Source Testing Program Description:

Triplicate 40-minute test runs will be performed at the TTU outlet for O<sub>2</sub>, NO<sub>x</sub>, CO, THC, CH<sub>4</sub> & NMOC. Two samples of the TTU inlet gas (landfill gas) will be collected and analyzed for fixed gases (O<sub>2</sub>, CO<sub>2</sub>, N<sub>2</sub> & C<sub>1</sub>-C<sub>6</sub>+), BTU/HHV, speciated VOC and Sulfur compounds (AP-42 Table 2.4-1). A single outlet sample will be collected and analyzed for speciated VOC. For each test run the stack volumetric flow rate will be calculated from the corrected meter fuel flow, BTU/HHV and stack oxygen concentration. During each test run all relevant operating data (gas flow and operating temperature) will be monitored and recorded.

A mass balance calculation will be used to determine the outlet SO<sub>2</sub> emission rate according to EPA Method 19.

#### Overview of Sampling-Flare

Parameter	Location	Methods	Duration	# of Runs
NO <sub>x</sub> , CO and O <sub>2</sub>	Exhaust	EPA 7E, 10 & 3A	40 mins	3
THC, CH <sub>4</sub> & NMOC	Exhaust	EPA 25A	40 mins	3
Speciated VOCs	Exhaust	EPA Method TO-15	grab	1
Flow Rate	Exhaust	EPA 19	40 mins	3
Speciated VOCs	Inlet	EPA Method TO-15	grab	2
Speciated Sulfurs	Inlet	ASTM D-5504-98	grab	2
Fuel analysis (BTU, O <sub>2</sub> , CO <sub>2</sub> , N <sub>2</sub> , C <sub>1</sub> -C <sub>6</sub> + & NMOC*)	Inlet	ASTM D-1945-96	grab	2
Fuel Flow Rate	Inlet	Metering System	40 mins	3

**All laboratory gas samples will be shipped by Ahtna personnel.**

### 4.0 Source Testing Procedures:

This section is intended to provide an overview of the sampling strategy and does not attempt to summarize the sampling procedures, which are described in detail in the reference methods.

EPA Method 1 (Traverse points), EPA Method 3A, 7E and 10 (O<sub>2</sub>, NO<sub>x</sub>, and CO), EPA Method 25A (THC/NMOC), and EPA Method 19 will be used to determine outlet emission rates. A single sample of the exhaust will be collected and analyzed using EPA Method TO-15 (speciated organic compounds). Two LFG samples will be collected and analyzed using ASTM D-1945 (O<sub>2</sub>, CO<sub>2</sub>, N<sub>2</sub>, C<sub>1</sub>-C<sub>6</sub>+ & BTU/HHV), EPA Method TO-15 (speciated organic compounds) and ASTM D-5504 (speciated inorganic compounds).

Outlet VOC analysis may consist of continuously analyzing total hydrocarbons (THC) at the exhaust with a FID analyzer. If applicable an integrated outlet sample will be collected at the exhaust and will be sent to a lab for methane and ethane analysis. The appropriate calibration checks will be performed prior and throughout the sampling. VOC will be assumed equal to THC or total non-methane/non-ethane hydrocarbons.

Exhaust SO<sub>x</sub> emissions will be calculated using mass balance calculations based on the measured inlet total sulfur content as allowed by EPA Method 19.

**EPA Method 1.** This method is used to determine the duct or stack area and appropriate traverse points that represent equal areas of the duct for sampling and velocity measurements. The point selection is made based on the type of test (particulate or velocity), the stack diameter and port location distance from flow disturbance.

**For the Continuous Emission Monitoring procedures (EPA Methods 7E, 3A, & 10),** a sample is extracted from the exhaust stack conditioned and analyzed by continuous monitoring gas analyzers in a test van. The sampling system consists of a stainless steel sample probe, heated Teflon sample line, glass-fiber particulate filter, glass moisture-condensation knockouts, Teflon sample transfer tubing, diaphragm pump and a stainless steel/Teflon manifold and flow control system. A constant sample and calibration gas supply pressure of 5 PSI is provided to each analyzer to avoid pressure variable response errors. The entire sampling system is leak checked before and after the sampling program. The BE sampling and analytical system is checked for linearity with zero, mid and high span calibrations, and is checked for system bias at the beginning and end of each test run. System bias is determined by pulling calibration gas through the entire sampling system. Individual test run calibrations will use the calibration gas that most closely matches the stack gas effluent. The calibration gases will be selected to fall approximately within the following instrument ranges; 80 to 90 percent for the high calibration, 40 to 60 percent for the mid range and zero. An additional low NO<sub>x</sub> calibration gas in the 20 to 30 percent range may also be used. Zero and calibration drift values and system bias will be determined for each test run.

**The reference method system and test results will meet the following criteria:**

Parameter	Limits
<b>System Criteria</b>	
Instrument Linearity	± 2% Calibration Span
System Bias	± 5% Calibration Span
Calibration Gas	± 2% Value
NO <sub>x</sub> converter efficiency	> 90%
<b>Test Criteria</b>	
Instrument Zero Drift	± 3% Calibration Span
Instrument Span Drift	± 3% Calibration Span

A 12-point traverse will be performed through the two available sample ports according to EPA Method 7E.

**EPA 25A (THC by FID)** is an accepted method for the determination of THC. A flame ionization detector (FID) total hydrocarbon continuous monitor is used for the sampling. The sampling and calibrations are performed through an all heated sample line connected directly to the THC analyzer without the removal of moisture. The FID in the analyzer is heated to 185 °C. The calibration gases are selected to fall within the following instrument ranges; 80 to 90 percent for the high calibration, 45 to 55 percent for the mid range calibration, 25 to 35 percent for the low range calibration and zero. Zero and mid calibration drift values are determined for each test run. A methane cut can be

performed by passing stack gas through activated charcoal to determine stack methane concentration. Bag samples will be collected through activated charcoal during each run and analyzed at the end of each run with the THC analyzer.

**EPA Method 25A will meet the following QA/QC method requirements:**

**System Criteria**

Instrument Linearity  $\leq$  5% Calibration Gas Conc.

**Test Criteria**

Instrument Zero Drift  $\leq$  3% Span Range

Instrument Span Drift  $\leq$  3% Span Range

The following continuous monitoring analyzers or equivalents will be used:

<u>Parameter</u>	<u>Make Model</u>	<u>Principle</u>
NO <sub>x</sub>	CAI 600CLD	Chemiluminescence
O <sub>2</sub>	CAI 100P	Paramagnetic
CO	TECO 48i	GFC/NDIR
THC/CH <sub>4</sub>	CAI 300M	Flame Ionization Detector

The following expected concentrations and calibration ranges are proposed. Certain gases and instrument ranges may be changed depending on availability and stack concentrations at the time of testing.

Anticipated Emissions & Test Van Measurement Ranges

	<u>Expected</u>	
NO <sub>x</sub>	15 ppm	Range 0-50 ppm
O <sub>2</sub>	12.5%	Range 0-25%
CO	<10 ppm	Range 0-50 ppm
THC/CH <sub>4</sub>	<10 ppm	Range 0-100 ppm (as methane)

Anticipated Calibration Gas Concentrations

	<u>Low Range</u>	<u>Mid Range</u>	<u>High Range</u>
NO <sub>x</sub>	N.A.	22.5 ppm	45 ppm
O <sub>2</sub>	N.A.	12.5%	21.0%
CO	N.A.	25 ppm	45 ppm
THC/CH <sub>4</sub>	25.0	45	85

All calibration gases are EPA Protocol #1 rated or are traceable to the National Institute of Standards and Technology. Calibration gas certificates will be included in the final test report. The analyzer data recording system consists of a digital strip chart and a computer Data Acquisition System (DAS).

**EPA Method 19** is used to determine stack gas volumetric flow rates using oxygen-based F-factors. F-factors are ratios of combustion gas volumes generated from heat input. The heating value of the fuel in BTU per cubic foot is determined from lab analysis of the fuel gas samples using ASTM D-



1945/3588 gas chromatography analytical procedures. Total fuel consumption for the flare is monitored on the systems control panel. During each test run gas readings and samples were taken and used for determining the stack flow rate. The total cubic feet per hour of fuel multiplied times the BTU/cf provides million BTU per hour (MMBtu/hr) heat input. The heat input in MMBtu/hr is multiplied by the F-factor (DSCF/MMBtu) and adjusted for the measured oxygen content of the source to determine volumetric flow rate. The flow rates are used to determine stack emission rates.

**EPA Method TO-15 & D-5504 analysis** is used to determine concentrations of Organic and inorganic compounds including Non-methane Organic Compounds (NMOC) and sulfurs compounds. Inlet gases are filled into tedlar bags in triplicate corresponding to the test program. The bags are labeled respectively then sent to a laboratory and analyzed for NMOC and speciated compounds using GC/MS (gas chromatography/mass specrometer) within 72 hours and GC/SCD (gas chromatography/Sulfur Chemiluminescence Detector) within 24 hours for sulfur.

**EPA Method ASTM D-1945 & D-3588 analysis** is used to determine the composition of gaseous fuels (e.g. Methane, fixed gases & BTU Content). Inlet gases are filled into a tedlar bag, the bag is labeled respectively then sent to a laboratory and analyzed for fixed gases, methane and C<sub>1</sub>-C<sub>6</sub> using GC/FID (gas chromatography/flame ionization detector). Each compound has calorific values that are used to calculate the combustion factors.

## **5.0 QA & QC Procedures:**

QA/QC Program: All quality assurance and quality control procedures will be followed as prescribed in the appropriate methods and Ahtna Quality Assurance Project Plan Former Fort Ord, California, Volume 1 Appendix D, Draft Final Revision 1 Operable Unit 2 Landfills.

Adherence to QA/QC procedures during field test preparation and field sampling will be the responsibility of the QA/QC Officer and/or Project Manager. This test program would include all QA/QC procedures specified in the test methods (equipment calibration, field data recording, contamination control and record keeping). Analytical QA/QC protocol will be the responsibility of the Analytical Liaison (Ahtna), and the laboratory manager and QA/QC coordinator assigned to this program by the laboratory Ahtna has subcontracted. Any deviations from stated protocols not mentioned herein would be discussed with the appropriate individuals prior to implementation.

Chain of Custody: A sample is considered to be under a person's custody if (1) if in a person's physical possession, (2) in view of the person after he has taken possession, (3) secured by that person that no one can tamper with the sample, or (4) secured by that person in an area which is restricted to authorized personnel. The following steps are taken to ensure sample identification and integrity:

- 1) Sample labels (identity, #, date, time)
- 2) C.O.C. seals (with sample #)
- 3) Field sample log book and field notes

- 4) C.O.C. record and analysis request sheet
- 5) Shipping papers (Courier, Fed. Ex.)
- 6) Receiving/Log-in (signed receipt of samples and their condition)

Once the sample has been received in the laboratory and the status of the sample integrity has been determined, the lab QA/QC supervisor is responsible for care and custody. The lab should be prepared to testify to the possession and security of the sample until analysis is complete.

In addition to the QA/QC procedures mentioned, BE uses EPA Protocol or 1% NIST Traceable calibration gases.

### **6.0 Source Test Report:**

Data reduction/reporting procedures: All data reduction is performed using Excel spreadsheet programs developed by BE. The report will be written by a senior project manager and will be reviewed by his peers. All supporting documentation, field data sheets, lab reports, lab and field QA/QC reports, emission calculations, etc., will be included in the final report. Calculations are contained in the referenced methods and in the APCD/AQMD source Test Procedure Guidelines where applicable. The expected date for a final report is approximately two weeks after the analytical work is completed. The analytical turn around time is approximately two to three weeks.

Submitted by,



Bobby Asfour  
Sr. Project Manager

### **Attachments:**

**Calculations and Nomenclature**  
**Sample System diagrams**  
**Report table of contents-Example**  
**Example Tabulated Data**  
**Stack Images**  
**Site Map and Regional Map**

## ***ATTACHMENTS***

**Standard Abbreviations for Reports**

Unit	Abbreviation	Unit	Abbreviation
billion	G	microgram	µg
Brake horsepower	bhp	milligram	mg
Brake horsepower hour	bhp-hr	milliliter	ml
British Thermal Unit	Btu	million	MM
capture efficiency	CE	minute	min
destruction efficiency	DE	Molecular Weight	M
Dry Standard Cubic Feet	DSCF	nanogram	ng
Dry Standard Cubic Feet per Minute	DSCFM	Parts per Billion	ppb
Dry Standard Cubic Meter	DSCM	Parts per Million	ppm
Dry Standard Cubic Meter per Minute	DSCMM	pennyweight per firkin	pw/fkn
grains per dry standard cubic foot	gr/DSCF	pound	lb
gram	g	pounds per hour	lbs/hr
grams per Brake horsepower hour	g/bhp-hr	pounds per million Btu	lbs/MMBtu
kilowatt	kW	second	sec
liter	l	Specific Volume, ft <sup>3</sup> /lb-mole	SV
Megawatts	MW	Thousand	k
meter	m	watt	W

**Common Conversions / Calculations / Constants**

1 gram = 15.432 grains

1 pound = 7000 grains

grams per pound = 453.6

bhp = 1.411 \* Engine kW, (where Engine kW = Generator kW output / 0.95) @ 95% efficiency

g/bhp-hr = 453\*ppm\*(MW / (385E6))\* 0.00848 \* f-factor \* (20.9 / (20.9-O<sub>2</sub>)); **CARB**

g/bhp-hr = lbs/hr \* 453.6 / bhp

2.59E-9 = Conversion factor for ppm to lbs/scf; **EPA 40CFR60.45**

Correction Multiplier for Standard Temperature = (460 + T<sub>std.</sub> °F) / 528

dscf / MMBTU = 8710 for Natural gas; **EPA Method 19**

Btu/ft<sup>3</sup> = 1040 for Natural Gas; **EPA Method 19**

lb/hr Part. Emission Rate = 0.00857 \* gr/dscf \* dscfm; **EPA Method 5**

lbs/hr = ppm / SV x dscfm x M \* 60; **CARB Method 100**; where SV ≈ 385E<sup>6</sup> @ 68°F or ≈ 379E<sup>6</sup> @ 60°F or ≈ 386E<sup>6</sup> @ 70°F.

Correction to 12% CO<sub>2</sub> = gr/dscf \* 12% / stack CO<sub>2</sub>%; **EPA Method 5**

Correction to 3% O<sub>2</sub> = ppm \* 17.9 / (20.9 - stack O<sub>2</sub> %); **CARB Method 100**

Correction to 15% O<sub>2</sub> = ppm \* 5.9 / (20.9 - stack O<sub>2</sub> %); **CARB Method 100**

dscfm = Gas Fd \* MMBtu/min \* 20.9 / (20.9 - stack O<sub>2</sub> %); **EPA Method 19**

lb/MMBtu = Fd \* M \* ppm \* 2.59E-9 \* 20.9 / (20.9 - stack O<sub>2</sub> %); **EPA Method 19**

**Standard Temperatures by District**

EPA	68 °F	NSAPCD - Northern Sonoma	68 °F
CARB	68 °F	PCAPCD - Placer	68 °F
BAAQMD - Bay Area	70 °F	SLOCAPCD - San Luis Obispo	60 °F
SJVUAPCD - San Joaquin	60 °F	SMAQMD - Sacramento	68°F de facto
SCAQMD - South Coast	60 °F	SCAQMD - Shasta County	68 °F
MBUAPCD - Monterey Bay	68 °F	YSAPCD - Yolo-Solano	68 °F
FRAQMD - Feather River	68 °F	AADBAPC - Amador County	68 °F

**EPA Method 1**

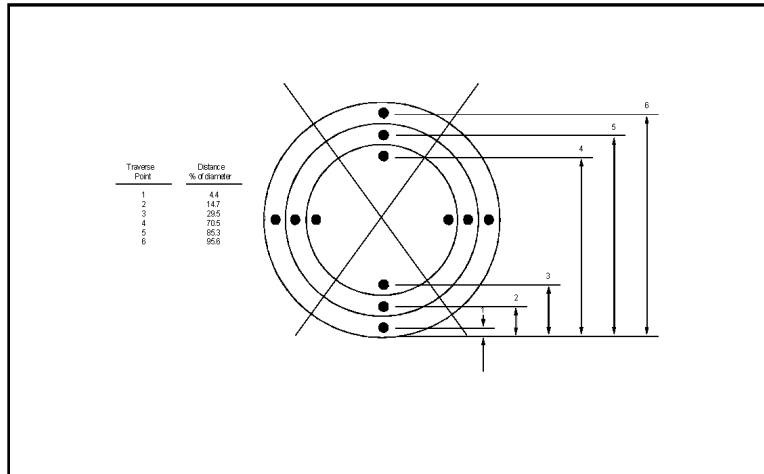

Figure 1-3. Example showing circular stack cross section divided into 12 equal areas, with location of traverse areas.

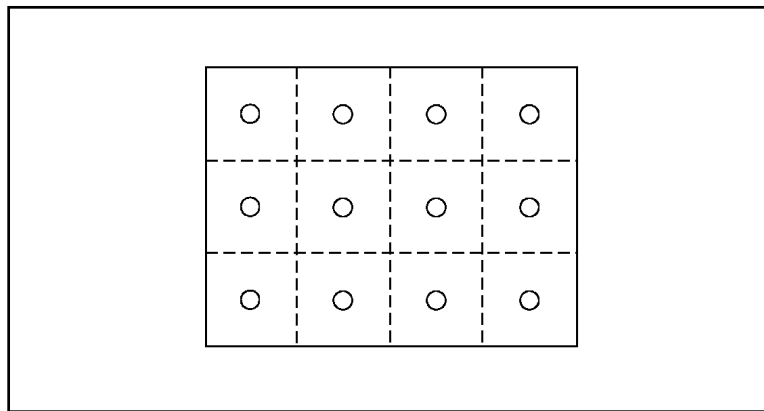
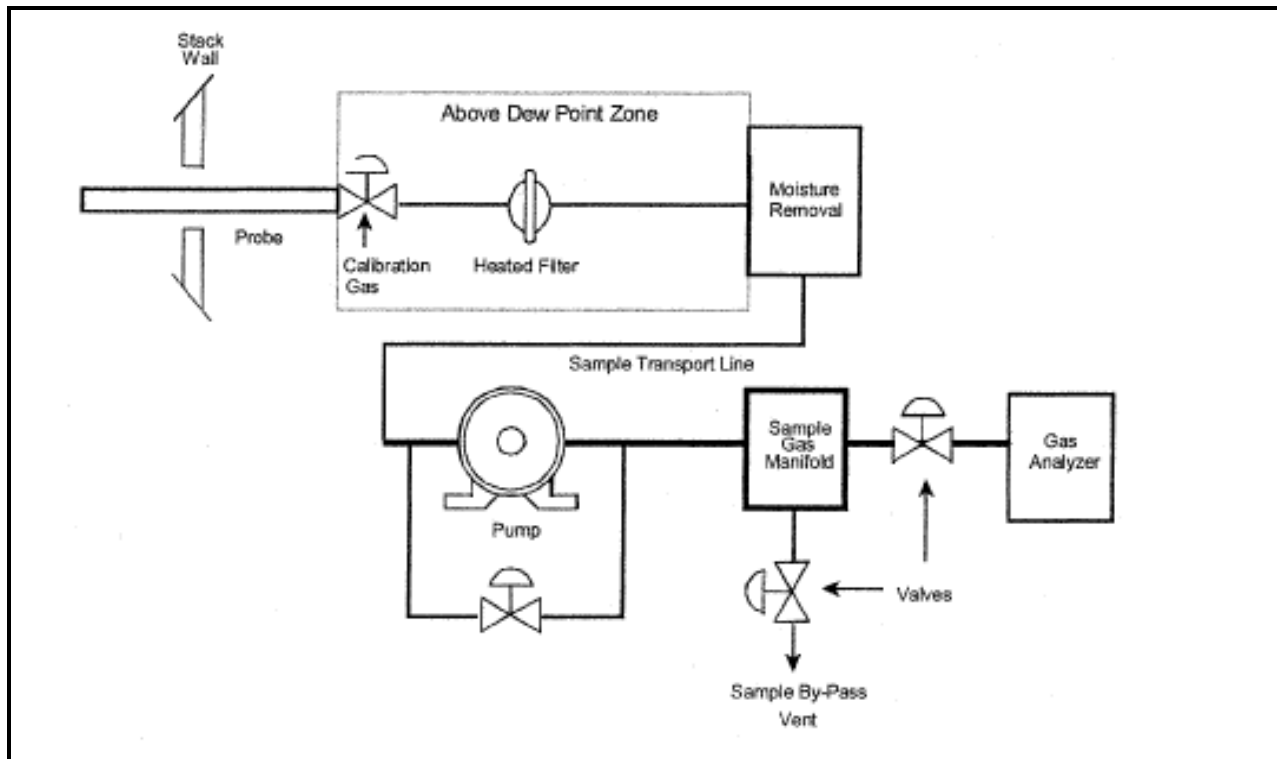

Figure 1-4. Example showing rectangular stack cross section divided into 12 equal areas, with traverse points at centroid of each area.



**EPA Methods 3A, 6C, 7E & 10**



**CEM Sampling Train**

**EPA Method 25A**

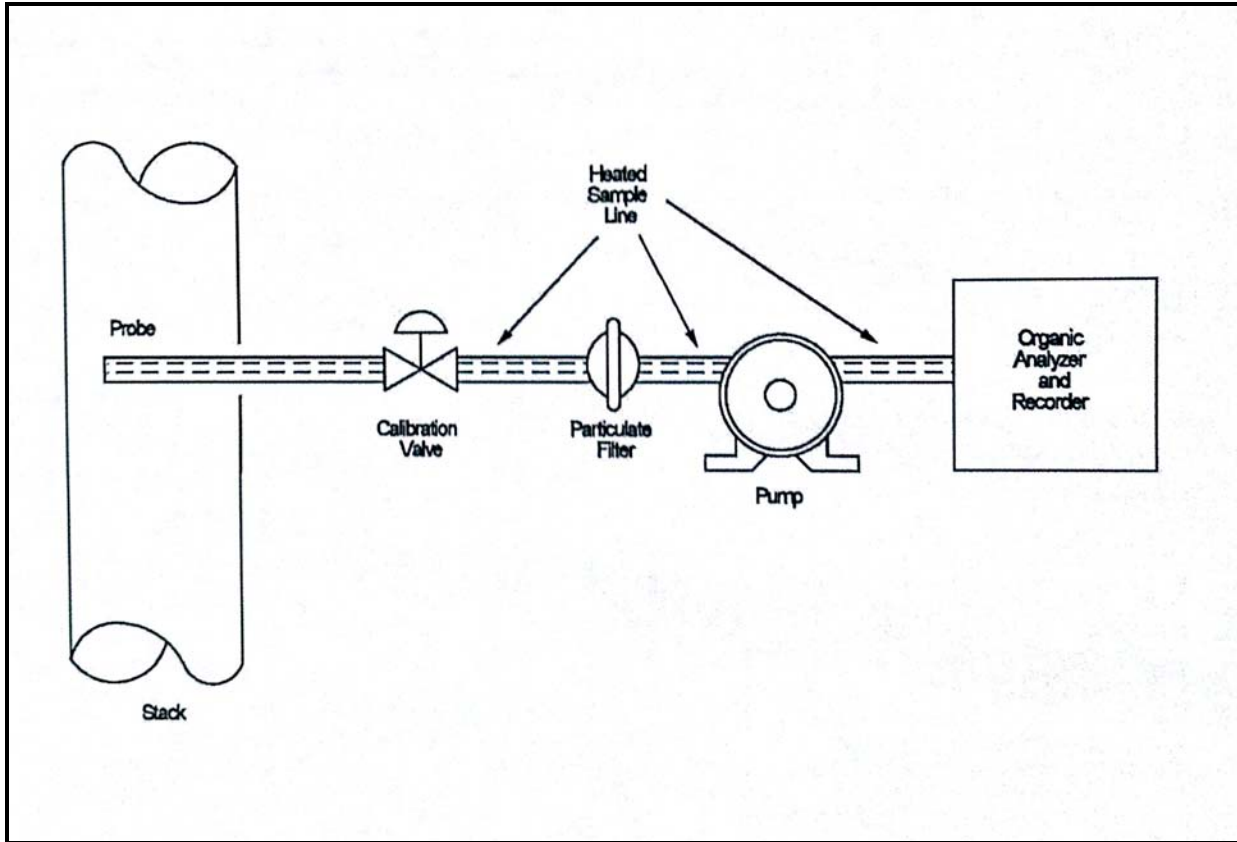

**Organic Concentration Measurement System**



## TABLE of CONTENTS

<b>SECTION 1. INTRODUCTION.....</b>	<b>1</b>
1.1. TEST PURPOSE.....	1
1.2. TEST LOCATION .....	1
1.3. TEST DATE(S).....	1
1.4. POLLUTANTS TESTED .....	1
1.5. SAMPLING AND OBSERVING PERSONNEL.....	1
1.6. OTHER IMPORTANT BACKGROUND INFORMATION .....	1
<b>SECTION 2. SUMMARY OF RESULTS .....</b>	<b>2</b>
2.1. EMISSION RESULTS .....	2
2.2. ALLOWABLE EMISSIONS.....	2
2.3. PROCESS DATA.....	2
2.4. COMMENTS: DISCUSSION OF QUALITY ASSURANCE AND ERRORS.....	2
<b>SECTION 3. SOURCE OPERATION.....</b>	<b>3</b>
3.1. PROCESS DESCRIPTION .....	3
3.2. FLOW DIAGRAM .....	3
3.3. PROCESS AND CONTROL OPERATING PARAMETERS DURING TESTING .....	3
3.4. NORMAL OPERATING PARAMETERS .....	3
3.5. TESTING OR PROCESS INTERRUPTIONS AND CHANGES .....	3
<b>SECTION 4. SAMPLING AND ANALYSIS PROCEDURES.....</b>	<b>4</b>
4.1. PORT LOCATION .....	4
4.2. POINT DESCRIPTION/LABELING – PORTS/STACK .....	4
4.3. METHOD DESCRIPTION, EQUIPMENT, SAMPLING, ANALYSIS AND QA/QC .....	4
<b>TABLE 1- TTU EMISSIONS RESULTS.....</b>	<b>7</b>
<b>APPENDICES .....</b>	<b>A</b>
A. Calculations & Nomenclature .....	A-1
B. Field Data Sheets .....	B-1
C. Laboratory Reports .....	C-1
D. Strip Chart Records.....	D-1
E. Calibration Gas Certificates .....	E-1
F. Stack Diagrams .....	F-1
G. Sampling System Diagrams .....	G-1
H. Source Test Plan .....	H-1

**TABLE #1**  
**EXAMPLE**  
**NO<sub>x</sub>, CO, THC, NMOC & SO<sub>x</sub> Emissions Results**  
**TTU**

TEST	1	2	3	AVERAGE	LIMIT
Test Location	Outlet	Outlet	Outlet		
Test Date	6/3/15	6/3/15	6/3/15		
Test Time	1026-1106	1120-1200	1208-1248		
Standard Temp., °F	68	68	68		
Flare Temp., °F	1,649	1,647	1,645		
Fuel F-Factor, DSCF/MMBtu	10,204	10,201	10,203		
Flare, MMBtu/hr	2.31	2.34	2.34	2.33	
Flare Load, %	9.6%	9.7%	9.7%	9.7%	
Inlet Methane (CH <sub>4</sub> ) Content, %	41.0%	41.0%	N.M.		
Inlet Fuel Flow Rate, DSCFM	94	95	95	95	
Outlet Flow Rate, DSCFM	1,028	1,004	1,018	1,017	
O <sub>2</sub> , %	12.91	12.63	12.74	12.76	
CO <sub>2</sub> , %	7.2	7.4	7.3	7.3	
H <sub>2</sub> O, %	8.9	9.1	9.0	9.0	
NO <sub>x</sub> , ppm	16.18	16.58	16.26	16.34	
NO <sub>x</sub> , lbs/hr	0.119	0.119	0.119	0.119	
NO <sub>x</sub> , lbs/day	2.86	2.86	2.85	2.86	
<b>NO<sub>x</sub>, lbs/MMBtu</b>	0.05	0.05	0.05	<b>0.05</b>	<b>0.06</b>
CO, ppm	<0.50	<0.50	<0.50	<0.50	
CO, lbs/hr	<0.002	<0.002	<0.002	<0.002	
CO, lbs/day	<0.05	<0.05	<0.05	<0.05	
<b>CO, lbs/MMBtu</b>	<0.0010	<0.0009	<0.0009	<b>&lt;0.0009</b>	<b>0.40</b>
THC, ppm (Wet)	1.09	<1.00	<1.00	<1.03	
THC, ppm (Dry)	1.19	<1.10	<1.10	<1.13	
THC, lbs/hr as methane	0.003	<0.003	<0.003	<0.003	
<b>THC, lbs/MMBtu as methane</b>	0.0013	<0.0012	<0.0012	<b>&lt;0.0012</b>	<b>0.03</b>
CH <sub>4</sub> , ppm as methane	<1.00	<1.00	<1.00	<1.00	
CH <sub>4</sub> , lbs/hr as methane	<0.003	<0.003	<0.003	<0.003	
CH <sub>4</sub> , lbs/MMBtu as methane	<0.0011	<0.0011	<0.0011	<0.0011	
NMOC, ppm as methane	<1.00	<1.00	<1.00	<1.00	
NMOC, ppm @ 3% O <sub>2</sub> as Methane	<2.24	<2.16	<2.19	<2.20	
NMOC, ppm @ 3% O <sub>2</sub> as Hexane	<0.37	<0.36	<0.37	<0.37	
NMOC, lbs/hr as methane	<0.003	<0.003	<0.003	<0.003	
NMOC, lbs/day as methane	<0.06	<0.06	<0.06	<0.06	
NMOC, lbs/MMBtu as methane	<0.0011	<0.0011	<0.0011	<0.0011	
Test Location	Inlet	Inlet	Inlet		
Inlet NMOC, ppm as methane (ASTM D-1945)	590.0	630.0	N.M.	610.0	
Inlet NMOC, lbs/hr as methane	0.138	0.149	N.M.	0.144	
<b>NMOC, Removal Efficiency %</b>	<b>&gt;98.15%</b>	<b>&gt;98.32%</b>	N.M.	<b>&gt;98.23%</b>	<b>98</b>
Inlet Total Sulfur, ppm as H <sub>2</sub> S	1.20	1.20	N.M.	1.20	
<b>Inlet Total Sulfur, grs/100scf as H<sub>2</sub>S</b>	0.08	0.08	N.M.	<b>0.08</b>	<b>50.00</b>
Inlet Total Sulfur, lbs/hr as SO <sub>2</sub>	0.0011	0.0011	N.M.	0.0011	
<b>Outlet SO<sub>2</sub>, ppm (Calculated)</b>	0.11	0.11	N.M.	<b>0.11</b>	<b>2000</b>
Inlet Total Sulfur, g/scf	0.00009	0.00009	N.M.	0.0001	

**WHERE:**

MW = Molecular Weight  
DSCFM = Dry Standard Cubic Feet Per Minute  
ppm = Parts Per Million Concentration  
lbs/hr = Pound Per Hour Emission Rate  
CO = Carbon Monoxide (MW = 28)  
NO<sub>x</sub> = Oxides of Nitrogen as NO<sub>2</sub> (MW = 46)  
THC = Total Hydrocarbons as Methane (MW = 16)  
SO<sub>2</sub> = Sulfur Dioxide (MW = 64)  
H<sub>2</sub>S = Hydrogen Sulfide (MW = 32)  
lbs/MMBtu = Pounds per million BTU  
g/scf = grams per standard cubic foot of inlet gas  
gr/100scf = grains per 100 standard cubic foot of inlet gas  
NMOC = Total Non-Methane Hydrocarbons as Methane (MW = 16) CH<sub>4</sub>  
NMOC = Total Non-Methane Hydrocarbons as Hexane (MW = 86.18) C<sub>6</sub>H<sub>14</sub>

**CALCULATIONS:**

lbs/hr = ppm \* MW \* DSCFM \* 60 / 385E6 (Tstd 68°F)  
lbs/day = lbs/hr \* 24  
Removal Efficiency = (inlet lbs/hr - outlet lbs/hr) / Inlet lbs/hr  
ppm @ 3% O<sub>2</sub> = ppm \* 17.9 / (20.9 - stack O<sub>2</sub>)  
lbs/MMBtu = Fd \* M.W. \* ppm \* 2.59E-9 \* (20.9 / (20.9 - %O<sub>2</sub>))  
ppm dry = ppm wet \* (100 / (100 - H<sub>2</sub>O%))  
g/scf = lbs/hr \* 453 / (Inlet SCFM \* 60)  
gr/100scf = ppm H<sub>2</sub>S \* 0.0626285  
SO<sub>2</sub> ppm (outlet) = lbs/hr / (DSCFM \* M.W. \* 60) \* 385E6

# Former Fort Ord TTU

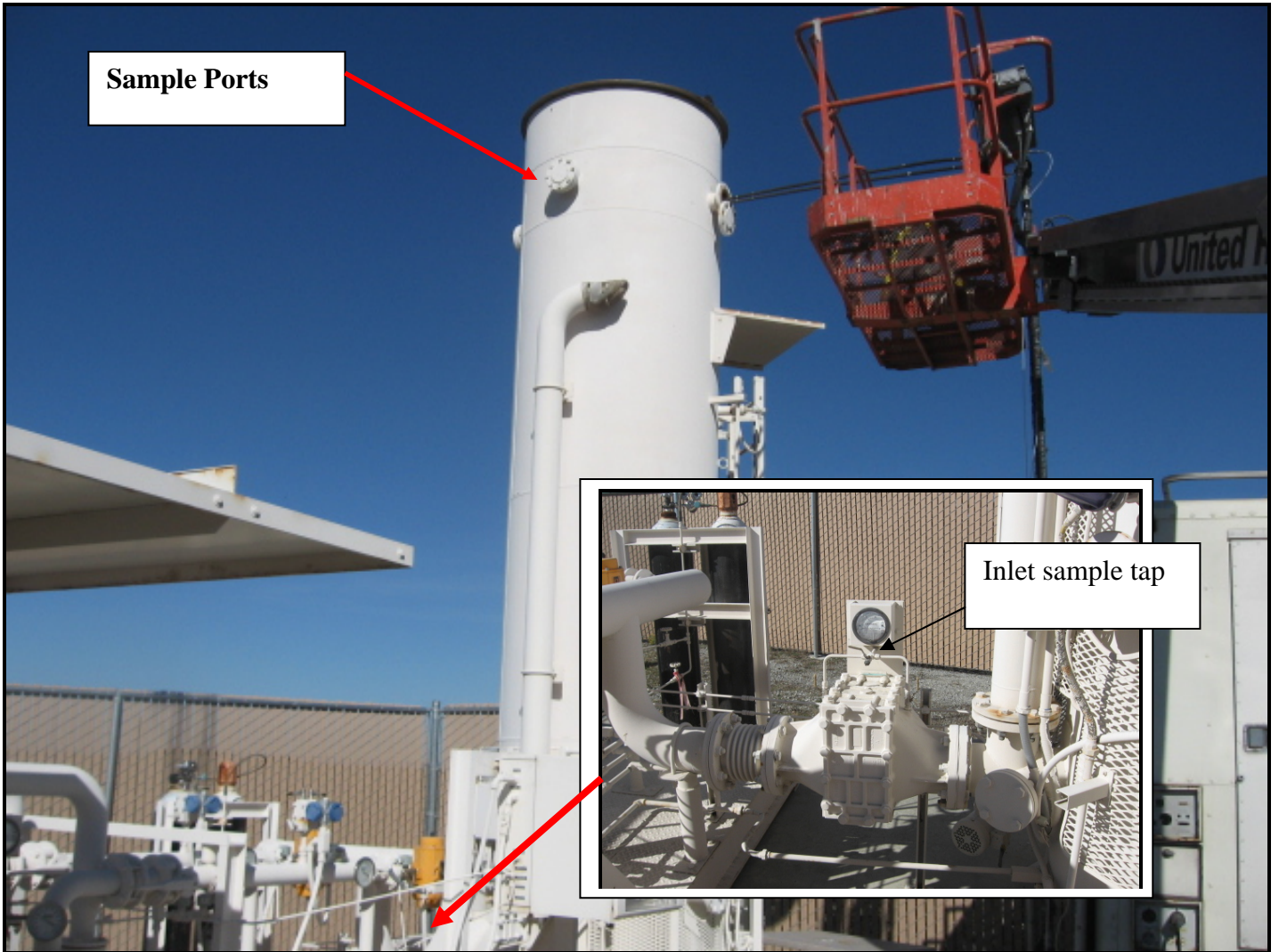

# Former Fort Ord Monterey, CA

## Thermal Treatment Unit (TTU)

### Site Map and Regional Map



Site Map

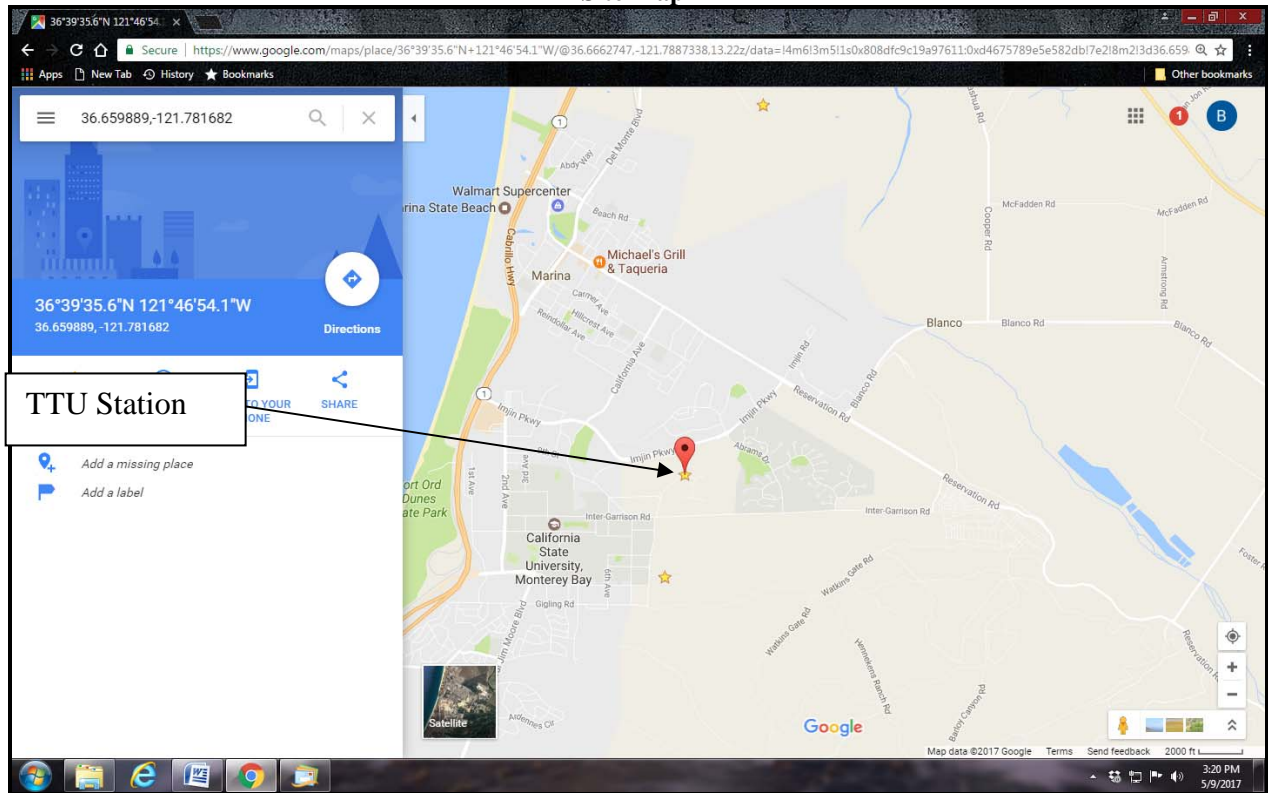

Regional Map

## **ATTACHMENT C**

### Field Documentation Forms

PM Jeff Fenton  
Ft. Ord. GW monitoring 2406  
12/14

Team 2  
SB/SK  
Sounder 36392  
Cor. -.06

0746 @ MW-02-04-180 WL-94.57  
SN2 @ 103' Cor. -.06

0757 sampled # 0650L002024F  
Dropped 1 @ 2

0808 @ MW-12-05-180 WL-74.61  
SN3 @ 88' Cor. -.06

<sup>18</sup>  
0820 sampled # 0650L012025F & 026D  
Dropped 1 @ 3

0835 @ MW-10-04-180 WL-259.75  
SN2 @ 271' Cor. -.06

0845 sampled # 0650L010027F  
Dropped 1 @ 2

0902 @ MW-002-25-A WL-129.38  
SN4 @ 146' Cor. -.06

0910 sampled # 0650L002028F  
Dropped 1 @ 4

0919 @ MW-002-53-180 WL-204.09  
SN5 @ 259' Cor. -.06

0927 sampled # 0650002029F  
Dropped 1 @ 5

0934 @ MW-002-39-180 WL-203.99  
SN4 @ 244' Cor. -.06

0943 sampled # 0650L002030F  
Dropped 1 @ 4

Team 2  
SB/SK  
12/14/06

0950 @ MW-002-24-180 WL-187.97  
SN3 @ 214 Cor. -.06

1002 sampled # 0650L002031F  
Dropped 1 @ 3

1009 @ MW-002-09-180R WL-156.08  
SN2 @ 199' Cor. -.06

<sup>1022</sup>  
1024 sampled # 0650L002032F & 033D  
Dropped 1 @ 2

1029 @ MW-002-06-A WL-106.26  
SN6 @ 128' Cor. -.06

1039 sampled # 0650L002034F  
Dropped 1 @ 6

1046 @ MW-002-06-180R WL-157.87  
SN4 @ 214' Cor. -.06

1053 sampled # 0650L002035F (ms/msd)  
Dropped 1 @ 4

1110 @ MW-002-07-180R WL-182.36  
SN3 @ 233' Cor. -.06

1117 sampled # 0650L002036F  
Dropped 1 @ 3

1123 @ MW-002-05-180 WL-155.49  
SN4 @ 215' Cor. -.06

1130 sampled # 0650L002037F  
Dropped 1 @ 1

**UNITED STATES ARMY CORPS OF ENGINEERS  
PROJECT SITE SAFETY LOG**

**GENERAL DATA**

Job # \_\_\_\_\_

Activity \_\_\_\_\_

Location Description \_\_\_\_\_

**DOCUMENTATION OF DAILY MORNING SAFETY MEETING:  
TOPICS OF DISCUSSION (check all that apply)**

_____ scope of work/SAP	_____ PPE requirements
_____ potential hazards	_____ equipment calibration
_____ health and safety plan highlights/revisions	_____ special topics (specify) _____
_____ emergency procedures	_____

**MEETING ATTENDEES:**

NAME	DATE	COMPANY	SIGNATURE

**DAILY INSPECTIONS: (Site crew chief shall initial each completed inspection)**

_____ PPE	_____ required eyewash station filled, and charged
_____ field equipment	_____ fire extinguisher
_____ vehicles	_____ communication check
_____ safety equipment	method _____
_____ field health and safety binder in vehicle	time _____
_____ first aid kit	

Note any deficiencies:

\_\_\_\_\_

\_\_\_\_\_

I acknowledge that the above health and safety program self audit and inspections have been performed prior to the initiation of scheduled work.

Signature of Site Health and Safety Officer (SHSO) \_\_\_\_\_

**LIST OF AUTHORIZED VISITORS NOT NORMALLY ASSIGNED TO THIS SITE**

(Note: SHSO must initial verification that each personnel record is present in the field binder.)

NAME	HAZWOPER CERTIFICATION	MEDICAL CLEARANCE	RESPIRATOR FIT TEST	FIRST AID/CPR



I have read and become familiar with all aspects of the Site Safety and Health Plan. I also understand that the Site Safety and Health Plan may be supplemented with other site--specific health and safety documents for which I will be held equally responsible.

NAME	DATE	COMPANY	SIGNATURE



296 12th St  
 Marina, CA 93933  
 (831) 384-3735

# CHAIN OF CUSTODY

Chain of Custody #: \_\_\_\_\_

Project Information:											Analysis Requested						Lab Sample Receipt		
Project Location: _____					Sampler/s: _____												Laboratory Sample Delivery		
Project Name: _____					Report To: Ahtna Environmental												Group #: _____		
Project Number: _____					E-Mail: _____												Custody Seal: _____		
Sampling Event: _____					Laboratory: Eurofins Air Toxics														
Lab Number	Sample Collection		Matrix	# of Containers	Preservative														
	Date	Time			None	HNO <sub>3</sub>	NaOH	HCL	H <sub>2</sub> SO <sub>4</sub>	MeOH	NaHSO <sub>4</sub>	Other							
Sample Number/Description	Date	Time	Matrix	# of Containers	None	HNO <sub>3</sub>	NaOH	HCL	H <sub>2</sub> SO <sub>4</sub>	MeOH	NaHSO <sub>4</sub>	Other							

Turnaround Time:  : Standard     : 3-5 Day Rush     : 48 Hour Rush     : 24 Hour Rush    Shipment Method: \_\_\_\_\_ Tracking ID: \_\_\_\_\_

Comments: \_\_\_\_\_

Chain of Custody Tracking:			
Relinquished By Sampler:	Date/Time:	Received By:	Date/Time:
Relinquished By:	Date/Time:	Received By:	Date/Time:
Relinquished By:	Date/Time:	Received By Laboratory:	Date/Time:



# INSTRUMENT CALIBRATION RECORD

Daily Log	Date:			
	No.			
	Sheet	1 Of		1

PROJECT NAME: FORT ORD, CA Project Number: 05055.02.15

FIELD ACTIVITY SUBJECT: Calibration of Landtec GEM 2000

**DESCRIPTION OF DAILY ACTIVITIES AND EVENTS**

Landtec Calibration Gas (high-level) Lot# \_\_\_\_\_, Expiration Date: \_\_\_\_\_

Compound	Initial Reading	Calibrated to	Comments
CH4		50%	
CO2		35%	

Landtec Calibration Gas (Oxygen) Lot# \_\_\_\_\_, Expiration Date: \_\_\_\_\_

Compound	Initial Reading	Calibrated to	Comments
O2		4%	

---

---

---

---

---

---

---

---

VISITORS ON SITE:	CHANGES FROM PLANS AND SPECIFICATIONS, AND OTHER SPECIAL ORDERS AND IMPORTANT DECISIONS:

WEATHER CONDITIONS:	IMPORTANT TELEPHONE CALLS:

PERSONNEL ON SITE:

SIGNATURE: DATE:

## **ATTACHMENT D**

### Three Phase Quality Control Process and Documentation

**PREPARATORY PHASE INSPECTION COVER SHEET**

Contract No.: \_\_\_\_\_

Date: \_\_\_\_\_

Task No.: \_\_\_\_\_

Location/Project: \_\_\_\_\_

**A. Key Personnel Present:**

	<u>Name</u>	<u>Position</u>	<u>Company</u>
1.	_____	_____	_____
2.	_____	_____	_____
3.	_____	_____	_____
4.	_____	_____	_____
5.	_____	_____	_____
6.	_____	_____	_____
7.	_____	_____	_____
8.	_____	_____	_____
9.	_____	_____	_____
10.	_____	_____	_____

**B. Submittals:**

1. Review submittals and/or submittal register. Have all applicable submittals been approved?  
Yes \_\_\_ No \_\_\_

If No, what items have not been submitted?

- a. \_\_\_\_\_
- b. \_\_\_\_\_
- c. \_\_\_\_\_

\_\_\_\_\_  
USACE Representative Signature

\_\_\_\_\_  
Quality Control Manager Signature

### INVESTIGATION PROJECT PREPARATORY PHASE INSPECTION CHECKLIST

Assessment Activity	Assessment Mechanism	Person(s) Responsible	Response Action	Completed by/Date
Have planning documents been prepared in accordance with the statement of work, regulatory requirements, and contract requirements?	Quality control review of document by Project Manager and QC reviewer.	Project Manager, QC Reviewer	Modify document as directed by reviewers	
Prior to project activities: Have planning documents been read by appropriate project personnel (including subcontractors) before work is conducted.	Documentation (e.g., sign-off form, note to file, email acknowledgement) that document has been read and requirements are understood.	Subcontractors as required. Project Manager, Task Manager, and Project Chemist to check signoff and forms.	Direct project personnel to read relevant documents.	
Prior to project activities: Has required preliminary work (e.g., clearance activities, permits, site access) been completed in accordance with project plan.	Comparison of information obtained from preliminary work completion assessment as specified in the project planning document(s).	Project Manager, Safety and Health Officer, Quality Control Manager, Task Manager, Project Chemist, Field Staff	Delay startup if necessary preliminary work has not been completed. Implement corrective actions by directing appropriate personnel or subcontractors to complete necessary preliminary work.	
Prior to project activities: Are staff and subcontractors prepared to implement project activities according to planning documents?	Review and discussion of planned activities prior to implementation.	Project Manager, Safety and Health Officer, Quality Control Manager, Task Manager, Project Chemist, Field staff.	Delay startup if staff and subcontractors are not prepared to implement activities <i>in</i> accordance with specification.	
Prior to project activities: Is necessary field equipment available and in acceptable working order?	Compare field equipment list with planned activities. Compare field equipment calibration documentation with project goals specified in the SAP.	Project Manager, Quality Control Manager, Task Manager, Project Chemist, Field staff.	Delay startup if equipment is unavailable or not in proper working order. Implement corrective actions to include use of alternate equipment, or recalibration of available equipment.	

**INITIAL PHASE INSPECTION COVER SHEET**

Contract No.: \_\_\_\_\_

Date: \_\_\_\_\_

Task No.: \_\_\_\_\_

Location/Project: \_\_\_\_\_

Description and Location of Work  
Inspected: \_\_\_\_\_

---

A. Key Personnel Present:

	<u>Name</u>	<u>Position</u>	<u>Company</u>
1.	_____	_____	_____
2.	_____	_____	_____
3.	_____	_____	_____
4.	_____	_____	_____
5.	_____	_____	_____
6.	_____	_____	_____
7.	_____	_____	_____
8.	_____	_____	_____
9.	_____	_____	_____
10.	_____	_____	_____

\_\_\_\_\_  
Quality Control Manager Signature

### INITIAL PHASE INSPECTION CHECKLIST

Assessment Activity	Assessment Mechanism	Person(s) Responsible	Response Action	Completed by/Date
Beginning of project activity: Is work being performed according to project plans?	Conduct field and laboratory audits.	Project Manager, Quality Control Manager, Task Manager, Project Chemist, Field staff.	Stop work if audits indicate significant deviation from project plan. Implement immediate or long- term corrective actions. Communicate deficiencies to USACE Project Manager.	
Early phase of project: Have necessary audits been performed?	Review project phase and check to see if required audits have been satisfactorily completed.	Project Manager, Project Manager, Quality Control Manager_	Stop work if reviewer decides that absence of audit jeopardizes successful implementation of project plans. Immediately schedule necessary audits.	
Ongoing throughout project: Are daily quality control reports being prepared according to contract requirements?	Review daily CQCRs from field supervisors.	Project Manager, Task Manager, Project Chemist, Project Staff	Correct deficiencies in reports or reporting delays.	
Ongoing throughout project: Do project plans adequately address any changes in project activities or goal?	Compare data gathered to assess conformance to the project plan and conceptual site model.	Project Manager, Safety and Health Officer, Quality Control System Manager, Task Manager, Project Chemist, Field staff.	Stop work if assessor decides that project plan deficiencies are significant. Implement corrective action to include modification of project plans. Notify USACE Project Manager.	
Ongoing throughout project: Do project plans adequately address any changes in project activities or goals?	Compare data gathered to assess conformance to the conceptual site model, data quality objectives, and project plan.	Project Manager, Quality Control Manager, Task Manager, Project Chemist, data users and evaluators.	Stop work if assessor decides that project plan deficiencies are significant. Implement corrective action to include modification of project plans. Notify USACE Project Manager. Identify data gaps.	



**FOLLOW-UP PHASE INSPECTION COVER SHEET**

Contract No.: \_\_\_\_\_

Date: \_\_\_\_\_

Task No.: \_\_\_\_\_

Location/Project: \_\_\_\_\_

Project/Area of Inspection:

\_\_\_\_\_  
\_\_\_\_\_  
\_\_\_\_\_

**A. Key Personnel Present:**

	<u>Name</u>	<u>Position</u>	<u>Company</u>
1.	_____	_____	_____
2.	_____	_____	_____
3.	_____	_____	_____
4.	_____	_____	_____
5.	_____	_____	_____
6.	_____	_____	_____
7.	_____	_____	_____
8.	_____	_____	_____
9.	_____	_____	_____
10.	_____	_____	_____

**B. Definable Features of Work:**

**Status of Inspection:**

\_\_\_\_\_  
\_\_\_\_\_  
\_\_\_\_\_  
\_\_\_\_\_  
\_\_\_\_\_  
\_\_\_\_\_  
\_\_\_\_\_  
\_\_\_\_\_  
\_\_\_\_\_  
\_\_\_\_\_  
\_\_\_\_\_  
\_\_\_\_\_  
\_\_\_\_\_  
\_\_\_\_\_  
\_\_\_\_\_  
\_\_\_\_\_  
\_\_\_\_\_  
\_\_\_\_\_  
\_\_\_\_\_  
\_\_\_\_\_  
\_\_\_\_\_

\_\_\_\_\_  
Quality Control Manager

**FOLLOW-UP PHASE INSPECTION CHECKLIST**

<b>Assessment Activity</b>	<b>Assessment Mechanism</b>	<b>Person(s) Responsible</b>	<b>Response Action</b>	<b>Completed by/Date</b>
Reporting phase of project: Have data reports been prepared in accordance with project plans?	Compare data reports to specifications detailed in planning documents.	Project Manager, Quality Control Manager, Task Manager, Project Chemist, data users and evaluators.	Revise documents and reports as appropriate.	
After draft report submittal or project completion: Are reports adequate to meet client and regulatory agency requirements?	Review client and agency comments. Prepare responses to comments.	Project Manager, Quality Control Manager, Task Manager, Project Chemist, data users and evaluators.	Revise documents and reports as appropriate.	
Have other definable features of work been completed in accordance to project requirements	Compare definable features of work with project requirements.	Project Manager, Quality Control Manager	Complete definable feature of work as required.	

## **ATTACHMENT E**

### **Electronic Data Deliverable File Specifications**

## **ADR Electronic Data Deliverable (EDD) File Specifications**

The ADR EDD consists of three separate, comma-delimited ASCII text files or Excel CSV files (two, if instrument calibration information is not required by the project). Each file corresponds to a table in the ADR application. These tables are identified as the Analytical Results Table (A1), Laboratory Instrument Table (A2), and Sample Analysis Table (A3). Each file follows the naming convention of using the Laboratory Reporting Batch ID (SDG Number or some other identifier for the EDD) followed by the table identifier (A1, A2, or A3), and then a ".txt" or ".csv" extension. For example, the EDD file names for a laboratory reporting batch identified as SDG001 that includes instrument calibration data would be as follows.

SDG001A1.txt or SDG001A1.csv  
SDG001A2.txt or SDG001A2.csv (A2 file is optional)  
SDG001A3.txt or SDG001A3.csv

### **Analytical Results Table (A1 File)**

The Analytical Results table contains analytical results and related information on an analyte level for field samples and associated laboratory quality control samples (excluding calibrations and tunes). Field QC blanks and laboratory method blanks must report a result record for each analyte reported within a method. The method target analyte list is matrix dependent and specified in the project library. Laboratory control samples (LCS and LCSD) and matrix spike samples (MS and MSD) must report a result record for every analyte specified as a spiked analyte in the project library. The project library is a reference table ADR uses for both EDD error checking and automated data review. The project library is populated with information from the project QAPP. Refer to the User Manual for detailed information on project libraries. Table 1 in this document lists all field names and their descriptions for the Analytical Results Table (A1).

### **Laboratory Instrument Table (A2 File)**

The Laboratory Instrument table contains results and related information on an analyte level for instrument initial calibration standards, initial calibration verification standards, continuing calibration standards, and GC/MS tunes. A record must exist for each target analyte reported in a method (specified in the project library), for every calibration type (the field named QCType) associated to samples reported in the EDD. Initial calibrations, initial calibration verifications, and associated samples are linked to each other using a unique Run Batch ID for every distinct initial calibration within a method. Continuing calibrations and associated samples are linked to each other using a unique Analysis Batch ID for every distinct continuing calibration within a method. GC/MS tunes are linked to initial and continuing calibrations (and hence samples) using the Run Batch and Analysis Batch IDs respectively. The Laboratory Instrument Table (A2) is optional. Depending on the level of validation required by the data user, the Laboratory Instrument table may not be requested in the deliverable. Table 2 in this document lists field names and descriptions for the Laboratory Instrument Table (A2).

## Sample Analysis Table (A3 File)

The Sample Analysis table contains information on a sample level for field samples and laboratory quality control analyses (excluding calibrations and tunes). A sample record exists for each sample/method/matrix/analysis type combination. Table 3 in this document lists field names and descriptions for the Sample Analysis Table (A3).

## EDD Field Properties

Tables 1, 2, and 3 in this document specify the EDD field properties for each file. These include the field name and sequence, field name description, data type and length for each field, and whether or not a particular field requires a standard field. Field elements in the EDD must be sequenced according to the order they appear in Tables 1, 2, and 3. For example, in the Analytical Result table (the A1 file), the field “ClientSampleID” will always be the first piece of information to start a new line of data (or database record), followed by the fields “LabAnalysisRefMethodID”, “AnalysisType”, and so on.

Table 4 in this document lists standard values for those fields that hold standard values. Required field constraints depend on the combination of sample, matrix, method, analyte type, and calibration or QC type information reported in a record. Tables 5 through 9 in this document indicate required fields for each EDD file (table) according to the method category, matrix, analyte type, sample, and QC or calibration type reported in a record.

When creating an EDD as a text file, use the ASCII character set in a file of lines terminated by a carriage return and line feed. No characters are allowed after the carriage return and line feed. Enclose each data set in double quotes (") and separate each field by a comma (comma delimited). Data fields with no information (null) may be represented by two consecutive commas. For example, in the Sample Analysis table, since the “Collected”, “ShippingBatchID”, and “Temperature” fields do not apply to laboratory generated QA/QC samples, the record for a Laboratory Control Sample by Method 8270C would be entered as follows. Note that the first two fields (“ProjectNumber” and “ProjectName”) are omitted in this example.

...“LCSW100598”,,”AQ”,,”LCSW100598”,,”LCS”,,”8270C”,... (and so on)

Do not pad fields with leading or trailing spaces if a field is populated with less than the maximum allowed number of characters. In the above example, although the “MatrixID” field can accommodate up to 10 characters, only 2 characters were entered in this field.

The EDD can be constructed within Excel and saved as .csv file for import into the application. Be sure to format all cells as text beforehand, otherwise Excel will reformat entered values in some cases.

## Table 1

### Field Descriptions for the Analytical Results Table (A1 file)

Contains laboratory test results and related information for field and QC samples (excluding instrument calibrations) on an analyte level for environmental chemistry including radiochemistry

Field Name	Field Name Description	Field Type	Field Length	Standard Value List
ClientSampleID	<p>Client or contractor's identifier for a field sample as reported on the chain-of-custody</p> <p>If a sample is analyzed as a laboratory duplicate, matrix spike, or matrix spike duplicate, append suffixes DUP, MS and MSD respectively to the Client Sample ID with no intervening spaces or hyphens (i.e. MW01DUP, MW01MS, and MW01MSD). For Method Blanks, LCS, and LCSD enter the unique LaboratorySampleID into this field</p> <p>Do not append suffixes to the ClientSampleID for dilutions, reanalyses, or re-extracts (the AnalysisType field is used for this distinction). For example, MW01<u>DL</u> and MW01<u>RE</u> are not allowed</p> <p>Parent sample records must exist for each MS and MSD. If an MS/MSD is shared between two EDDs, records for the MS/MSD and its parent sample must exist in the Analytical Results table for both EDDs.</p>	Text	25	NO
LabAnalysisRefMethodID	Laboratory reference method ID. The method ID may be an EPA Method number or a Lab Identifier for a method such as a SOP Number, however; method ID is specified by the project. The method ID must be entered into the standard list.	Text	25	YES (specified in project plan)
AnalysisType	Defines the analysis type (i.e., Dilution, Reanalysis, etc.). This field provides distinction for sample result records when multiple analyses are submitted for the same sample, method, and matrix; for example dilutions, re-analyses, and re-extracts.	Text	10	YES (See Table 4)
LabSampleID	<p>Laboratory tracking number for field samples and lab generated QC samples such as method blank, LCS, and LCSD. There are no restrictions for the LabSampleID except for field length and that the LabSampleID must be distinct for a given field sample or lab QC sample and method.</p> <p>Suffixes may be applied to the LabSampleID to designate dilutions, reanalysis, etc.</p>	Text	25	NO
LabID	Identification of the laboratory performing the analyses.	Text	7	NO
ClientAnalyteID	<p>CAS Number or unique client identifier for an analyte or isotope.</p> <p>If a CAS Number is not available, use a unique identifier provided by the client or contractor. The ClientAnalyteID for a particular target analyte or isotope should be specified by the project and must exist in the standard value tables for Analytes.</p> <p>For the LCS, LCSD, MS, and MSD, it is only necessary to report the compounds designated as spikes in the library (and surrogates for organic methods.)</p> <p>For TICs from GC/MS analyses, enter the retention time in decimal minutes as the Client Analyte ID.</p>	Text	12	YES (specified by project)

## Table 1

### Field Descriptions for the Analytical Results Table (A1 file)

Contains laboratory test results and related information for field and QC samples (excluding instrument calibrations) on an analyte level for environmental chemistry including radiochemistry

Field Name	Field Name Description	Field Type	Field Length	Standard Value List
AnalyteName	Chemical name for the analyte or isotope. The project specifies how an analyte or isotope is named. The analyte name must be associated to a ClientAnalyteID in the standard values table for Analytes (excluding compounds designated as TIC's).	Numeric	60	YES (specified by project)
Result	Result value for the analyte or isotope.  Entries must be numeric. For non-detects of target analytes or isotopes and spikes, do not enter "ND" or leave this field blank. If an analyte or spike was not detected, enter the reporting limit value corrected for dilution and percent moisture as applicable. Do not enter "0"	Text	10	NO
ResultUnits	The units defining how the values in the Result, DetectionLimit, and ReportingLimit fields are expressed. For radiochemistry this also includes how the value in the Error field is expressed.	Text	10	YES (specified by project in the library)
LabQualifiers	A string of single letter result qualifiers assigned by the lab based on client-defined rules and values.  <u>The "U" Lab Qualifier must be entered for all non-detects.</u> Other pertinent lab qualifiers may be entered with the "U" qualifier. Order is insignificant. Lab qualifiers other than those listed in the standard values table may be used. If so, these must be added to the standard value table in the application.	Text	7	YES (See Table 4)
DetectionLimit	For radiochemistry methods, the minimum detectable activity for the isotope being measured.  For all other methods: The minimum detection limit value for the analyte being measured.  <b>For DoD QSM enter the Limit of Detection (LOD)</b>	Numeric	10	NO
DetectionLimitType	Specifies the type of detection limit (i.e., MDA, MDL, IDL, etc.).	Text	10	YES (See Table 4)
RetentionTime or Error	<u>For radiochemistry methods only</u> , enter the 2 Sigma Counting Error. The units for error are entered in the ResultUnits field.  <u>For GC/MS methods only</u> , enter the time expressed in decimal minutes between injection and detection for <u>GC/MS TICs only</u>  <u>For target analytes in all other methods</u> , leave this field blank. Note: GC retention times are not evaluated at this time.	Text	5	NO
AnalyteType	Defines the type of result, such as tracer, surrogate, spike, or target compound.	Text	7	YES (See Table 4)

## Table 1

### Field Descriptions for the Analytical Results Table (A1 file)

Contains laboratory test results and related information for field and QC samples (excluding instrument calibrations) on an analyte level for environmental chemistry including radiochemistry

Field Name	Field Name Description	Field Type	Field Length	Standard Value List
PercentRecovery	<p>For radiochemistry methods: The tracer yield, if applicable.</p> <p>For all other analytical methods: The percent recovery value of a spiked compound or surrogate.</p> <p>If the spike or surrogate was not recovered because of dilution, enter "DIL". If a spike or surrogate was not recovered because of matrix interference, enter "INT". If a spike or surrogate was not recovered because it was not added to the sample, enter "NS".</p>	Numeric	5	NO
RelativePercentDifference	<p>The relative percent difference (RPD) of two QC results, such as MS/MSD, LCS/LCSD, and Laboratory Duplicates. Report RPD in Laboratory Duplicate, LCSD, and MSD records only.</p> <p>If the RPD is not calculable, enter "NC".</p>	Numeric	5	NO
ReportingLimit	<p>Reporting limit value for the measured analyte or isotope Factor in the dilution factor and percent moisture correction, if applicable. The Reporting Limit for each analyte and matrix in a given method is specified in the project library or QAPP.</p> <p><b>For DoD QSM enter the Limit of Quantitation (LOQ)</b></p>	Numeric	10	NO
ReportingLimitType	<p>Specifies the type of reporting limit (i.e., CRQL, PQL, SQL, RDL, etc). The Reporting Limit Type for each method and matrix is specified in the project library or QAPP.</p>	Text	10	YES (specified by the project)



## Table 1

### Field Descriptions for the Analytical Results Table (A1 file)

Contains laboratory test results and related information for field and QC samples (excluding instrument calibrations) on an analyte level for environmental chemistry including radiochemistry

Field Name	Field Name Description	Field Type	Field Length	Standard Value List
ReportableResult	<p>This field indicates whether or not the laboratory chooses an individual analyte or isotope result as reportable. Enter "YES" if the result is reportable. Enter "NO" if the result is not reportable. This field applies to target analytes only.</p> <p>If only one analysis is submitted for a particular sample and method, enter "YES" for all target compounds (where Analyte Type = TRG). For GC/MS methods enter yes for tentatively identified compounds ( where Analyte Type = TIC).</p> <p>If two or more analyses are submitted for a particular sample and method (i.e. initial analysis, reanalysis and/or dilutions), enter "YES" from only <u>one</u> of the analyses for each target compound. For example: a sample was run a second time at dilution because benzene exceeded the calibration range in the initial, undiluted analysis. All target analytes are reported in each analysis. For the initial analysis, (Analysis Type = RES), enter "NO" for benzene and enter "YES" for all other compounds. For the diluted analysis (Analysis Type = DL), enter "YES" for benzene and enter "NO" for all other compounds.</p> <p>For TICs (Analyte Type = TIC), if more than one analysis is submitted for a particular sample and method, choose only one of the analyses where Reportable Result = YES for <u>all</u> TICs. For example, a sample was run a second time because one or more target compounds exceeded the calibration range in the undiluted analysis. Choose a particular analysis and enter "YES" for all TICs. In the other analysis enter "NO" for all TICs.</p> <p>Note that it is not necessary to report the full target analyte list for the initial result, dilution, re-analysis, or re-extraction. However, each target analyte must be reported YES once and once only in the case of multiple analyses for a given sample, method, and matrix. In the case of organics, all surrogates must be reported for all analyses submitted for a given sample, method, and, matrix.</p>	Text	3	YES (See Table 4)
MDL_DoD	<p>This field is not part of the standard ADR EDD format.</p> <p><b>For DoD QSM enter the MDL, otherwise leave blank. (ADR does not perform error checks on this field)</b></p>	Numeric	10	NO

**Table 2****Field Descriptions for the Laboratory Instrument Table (A2 file)**

Contains related to laboratory instrument calibration on an analyte level and GC/MS Tune information. This table is optional depending on project requirements. **Do not report Table A2 for radiochemistry methods.**

Field Name	Field Name Description	Field Type	Field Length	Standard Value List
InstrumentID	Laboratory instrument identification.	Text	15	NO
QCType	Type of instrument QC (i.e., Instrument_Performance_Check or type of calibration standard).	Text	10	YES (See Table 4)
Analyzed	Analysis date/time for BFB, DFTPP, initial calibration verification standards, calibration verification standards, and continuing calibration standards. For the <u>initial calibration</u> , enter date and time of the <u>last</u> standard analyzed. Also, see comments about initial calibrations in the Alternate_Lab_Analysis_ID field name description.	Date/Time	*	NO
AlternateLab_AnalysisID	Common laboratory identification used for standards (i.e., VOA STD50, CCAL100, BFB50, etc). For initial calibration, enter ICAL. Information from the initial calibration is entered as one record for each analyte that summarizes the results of the initial calibration (i.e. %RSD, correlation coefficient, and avg RF). Records are <u>not</u> entered for each individual standard within the initial calibration.	Text	12	NO
LabAnalysisID	Unique identification of the raw data electronic file associated with the calibration standard or tune (i.e., 9812101MS.DV). Leave this field blank for the initial calibration. See comments about initial calibrations in the Alternate_Lab_Analysis_ID field description. This field is only applicable where an electronic instrument file is created as part of the analysis.	Text	15	NO
LabAnalysisRefMethodID	Laboratory reference method ID (i.e., 8260B, 8270C, 6010B, etc.). The method ID is specified by the project. The LabAnalysisRefMethodID must be in the standard value list for Method IDs.	Text	25	YES (specified by the project)
ClientAnalyteID	CAS number or unique client identifier for an analyte. If a CAS number is not available, use a unique identifier provided by the client. The unique identifier for a particular analyte should be specified by the project and must exist in the standard value list for ClientAnalyteID.  Records for each calibration must report the full target analyte list including surrogates as applicable. The target analyte list is specified for each method and matrix in the project	Text	12	YES (specified by the project)
AnalyteName	The chemical name for the analyte. The project specifies how an analyte is named. The AnalyteName must be associated to a ClientAnalyteID in the standard values.	Text	60	YES (specified by the project)

**Table 2****Field Descriptions for the Laboratory Instrument Table (A2 file)**

Contains related to laboratory instrument calibration on an analyte level and GC/MS Tune information. This table is optional depending on project requirements. **Do not report Table A2 for radiochemistry methods.**

Field Name	Field Name Description	Field Type	Field Length	Standard Value List
RunBatch	Unique identifier for a batch of analyses performed on one instrument under the control of one initial calibration and initial calibration verification. The Run Batch ID links both the initial calibration and initial calibration verification to subsequently analyzed and associated continuing calibrations, field samples, and QC analyses. For GC/MS methods, the Run_Batch ID also links a BFB or DFTPP tune and the initial calibration and initial calibration verification standards to associated samples and method QC analyses. A new and unique Run Batch ID must be used with every new initial calibration.	Text	12	NO
AnalysisBatch	<p>Unique laboratory identifier for a batch of analyses performed on one instrument and under the control of a continuing calibration or continuing calibration verification. The Analysis Batch ID links the continuing calibration or calibration verification to subsequently analyzed and associated field sample and QC analyses. For GC/MS methods, the Analysis Batch ID also links the BFB or DFTPP tune. A new and unique Analysis Batch ID must be used with every new continuing calibration or continuing calibration verification.</p> <p>For GC methods, only report opening standards, do not include closing standards (unless the closing standard functions as the opening standard for a subsequent set of analyses, in which case a new and unique Analysis Batch ID is assigned).</p> <p>When dual or confirmation columns/detectors are used, enter results from the primary column/detector only (this is similar to CLP Pesticide reporting).</p>	Text	12	NO
LabReportingBatch	Unique laboratory identifier for a batch of samples including associated calibrations and method QC, reported as a group by the lab (i.e., lab work order #, log-in #, or SDG). Links all instrument calibrations, samples, and method QC reported as a group or SDG.	Text	12	NO
PercentRelativeStandard Deviation	<p>The standard deviation relative to the mean used to evaluate initial calibration linearity. Organic methods may use either %RSD or Correlation Coefficient.</p> <p>If applicable, enter the %RSD. Leave this field blank if the Correlation Coefficient is used.</p>	Numeric	5	NO
CorrelationCoefficient	<p>The correlation coefficient resulting from linear regression of the initial calibration. For metals by ICAP, enter '1.0' if a two-point initial calibration was analyzed. Organic methods may use either %RSD or Correlation Coefficient.</p> <p>If applicable, enter the Correlation Coefficient. Leave this field blank if the %RSD is used</p>	Numeric	5	NO
RelativeResponseFactor	<p>This field applies to GC/MS only.</p> <p>For continuing calibration enter the relative response factor.</p> <p>For initial calibration enter the <u>average</u> relative response factor. Refer to comments about initial calibration records in the field description for Alternate_Lab_Analysis_ID.</p>	Numeric	5	NO

**Table 2****Field Descriptions for the Laboratory Instrument Table (A2 file)**

Contains related to laboratory instrument calibration on an analyte level and GC/MS Tune information. This table is optional depending on project requirements. **Do not report Table A2 for radiochemistry methods.**

Field Name	Field Name Description	Field Type	Field Length	Standard Value List
Percent_Difference (or Percent Recovery)	<p>For <u>organic methods</u>, this field is the difference between 2 measured values expressed as a percentage.</p> <p>If %RSD is reported, enter the % difference between the average response factor of the initial calibration (IC) and the response factor of the initial calibration verification (ICV) or continuing calibration (CCV).</p> <p>If correlation coefficient is used, enter the % difference between the true value and the measured value.</p> <p>The Percent_Difference is expressed as a negative or positive value. Do not express Percent_Difference as an absolute value. Use a negative value if the CCV or ICV response factor is less than the IC average response factor or, in the case of correlation coefficient, the CCV or ICV measured value is less than the true value. Use a positive value if the CCV or ICV response factor is greater than the IC average response factor, or in the case of correlation coefficient, the CCV or ICV measured value is greater than the true value.</p> <p>For <u>inorganic methods</u>, this field is the recovery of an analyte expressed relative to the true amount (i.e., %R for a metal in the continuing calibration or initial calibration verification by Method 6010B).</p>	Numeric	5	NO
PeakID01	Identifies individual m/z ions for GC/MS tuning compounds. For BFB enter 50, for DFTPP enter 51.	Numeric	10	NO
PercentRatio01	<p>For BFB enter the relative percent abundance of m/z 50 measured relative to the raw abundance of m/z 95.</p> <p>For DFTPP enter the relative percent abundance of m/z 51 measured relative to the raw abundance of m/z 198.</p>	Numeric	10	NO
PeakID02	Identifies individual m/z ions for GC/MS tuning compounds. For BFB enter 75, for DFTPP enter 68.	Numeric	10	NO
PercentRatio02	<p>For BFB enter the relative percent abundance of m/z 75 measured relative to the raw abundance of m/z 95.</p> <p>For DFTPP enter the relative percent abundance of m/z 68 measured relative to the raw abundance of m/z 69.</p>	Numeric	10	NO
PeakID03	Identifies individual m/z ions for GC/MS tuning compounds. For BFB enter 95, for DFTPP enter 69.	Numeric	10	NO
PercentRatio03	<p>For BFB enter the ion abundance of m/z 95 as 100 percent.</p> <p>For DFTPP enter the relative percent abundance of m/z 69 measured relative to the raw abundance of m/z 198.</p>	Numeric	10	NO
PeakID04	Identifies individual m/z ions for GC/MS tuning compounds. For BFB enter 96, for DFTPP enter 70.	Numeric	10	NO

**Table 2****Field Descriptions for the Laboratory Instrument Table (A2 file)**

Contains related to laboratory instrument calibration on an analyte level and GC/MS Tune information. This table is optional depending on project requirements. **Do not report Table A2 for radiochemistry methods.**

Field Name	Field Name Description	Field Type	Field Length	Standard Value List
PercentRatio04	For BFB enter the relative percent abundance of m/z 96 measured relative to the raw abundance of m/z 95.  For DFTPP enter the relative percent abundance of m/z 70 measured relative to the raw abundance of m/z 69	Numeric	10	NO
PeakID05	Identifies individual m/z ions for GC/MS tuning compounds. For BFB enter 173, for DFTPP enter 127.	Numeric	10	NO
PercentRatio05	For BFB enter the relative percent abundance of m/z 173 measured relative to the raw abundance of m/z 174.  For DFTPP enter the relative percent abundance of m/z 127 measured relative to the raw abundance of m/z 198	Numeric	10	NO
PeakID06	Identifies individual m/z ions for GC/MS tuning compounds. For BFB enter 174, for DFTPP enter 197.	Numeric	10	NO
PercentRatio06	For BFB enter the relative percent abundance of m/z 174 measured relative to the raw abundance of m/z 95.  For DFTPP enter the relative percent abundance of m/z 197 measured relative to the raw abundance of m/z 198.	Numeric	10	NO
PeakID07	Identifies individual m/z ions for GC/MS tuning compounds. For BFB enter 175, for DFTPP enter 198.	Numeric	10	NO
PercentRatio07	For BFB enter the relative percent abundance of m/z 175 measured relative to the raw abundance of m/z 174.  For DFTPP enter the ion abundance of m/z 198 as 100 percent.	Numeric	10	NO
PeakID08	Identifies individual m/z ions for GC/MS tuning compounds. For BFB enter 176, for DFTPP enter 199.	Numeric	10	NO
PercentRatio08	For BFB enter the relative percent abundance of m/z 176 measured relative to the raw abundance of m/z 174.  For DFTPP enter the relative percent abundance of m/z 199 measured relative to the raw abundance of m/z 198.	Numeric	10	NO
PeakID09	Identifies individual m/z ions for GC/MS tuning compounds. For BFB enter 177, for DFTPP enter 275.	Numeric	10	NO
PercentRatio09	For BFB enter the relative percent abundance of m/z 177 measured relative to the raw abundance of m/z 176.  For DFTPP enter the relative percent abundance of m/z 275 measured relative to the raw abundance of m/z 198.	Numeric	10	NO
PeakID10	Identifies individual m/z ions for GC/MS tuning compounds. For BFB leave blank, for DFTPP enter 365.	Numeric	10	NO

## Table 2

### Field Descriptions for the Laboratory Instrument Table (A2 file)

Contains related to laboratory instrument calibration on an analyte level and GC/MS Tune information. This table is optional depending on project requirements. **Do not report Table A2 for radiochemistry methods.**

Field Name	Field Name Description	Field Type	Field Length	Standard Value List
PercentRatio10	For BFB leave blank.  For DFTPP enter the relative percent abundance of m/z 365 measured relative to the raw abundance of m/z 198.	Numeric	10	NO
PeakID11	Identifies individual m/z ions for GC/MS tuning compounds. For BFB leave blank, for DFTPP enter 441.	Numeric	10	NO
PercentRatio11	For BFB leave blank.  For DFTPP the percent abundance of m/z 441 measured relative to the raw abundance of m/z 443	Numeric	10	NO
PeakID12	Identifies individual m/z ions for GC/MS tuning compounds. For BFB leave blank, for DFTPP enter 442.	Numeric	10	NO
PercentRatio12	For BFB leave blank.  For DFTPP enter the relative percent abundance of m/z 442 measured relative to the raw abundance of m/z 198.	Numeric	10	NO
PeakID13	Identifies individual m/z ions for GC/MS tuning compounds. For BFB leave blank, for DFTPP enter 443.	Numeric	10	NO
PercentRatio13	For BFB leave blank.  For DFTPP enter the relative percent abundance of m/z 443 measured relative to the raw abundance of m/z 442.	Numeric	10	NO

\* Date/time format is: MM/DD/YYYY hh:mm where MM = month, DD = day, YYYY = four digits of the year, hh = hour in 24 hour format, and mm = minutes.

**Table 3**  
**Field Description for the Sample Analysis (A3 file)**

This table contains information related to analyses of field samples and laboratory QC samples (excluding calibrations and tunes) on a sample level for environmental chemical analyses including radiochemistry

Field Name	Field Name Description	Field Type	Field Length	Standard Value List
ProjectNumber	Project number assigned by the client.	Text	30	YES (specified by project)
ProjectName	Project name assigned by the client.	Text	90	YES (specified by project)
ClientSampleID	<p>Client or contractor's identifier for a field sample</p> <p>If a sample is analyzed as a laboratory duplicate, matrix spike, or matrix spike duplicate, append suffixes DUP, MS and MSD respectively to the Client Sample ID with no intervening spaces or hyphens (i.e. MW01DUP, MW01MS, and MW01MSD). For Method Blanks, LCS, and LCSD enter the unique LaboratorySampleID into this field</p> <p>Do not append suffixes to the ClientSampleID for dilutions, reanalyses, or re-extracts (the Analysis_Type field is used for this distinction). For example, MW01DL and MW01RE are not allowed</p> <p>Parent sample records must exist for each MS and MSD. If an MS/MSD is shared between two EDDs, records for the MS/MSD and its parent sample must exist in the Sample Analysis table for both EDDs.</p>	Text	25	NO
Collected	<p><u>For radiochemistry methods</u> the Date of sample collection. Refer to the date format for radiochemistry methods at the end of this table.</p> <p><u>For all other methods</u> the Date and Time of sample collection. Refer to the date/time format at the end of this table.</p> <p>Leave this field blank for Method Blank, LCS, and LCSD</p>	Date/Time	16*	NO
MatrixID	Sample matrix (i.e., AQ, SO, etc.)	Text	10	YES (See Table 4)
LabSampleID	<p>Laboratory tracking number for field samples and lab generated QC samples such as method blank, LCS, and LCSD.</p> <p>There are no restrictions for the LabSampleID except field length and that the LabSampleID must be unique for a given field sample or lab QC sample and method.</p>	Text	25	NO
QCType	This record identifies the type of quality control sample QC (i.e., Duplicate, LCS, Method Blank, MS, or MSD). <u>For regular samples, leave this field blank.</u>	Text	10	YES (See Table 4)
ShippingBatchID	Unique identifier assigned to a cooler or shipping container used to transport client or field samples. Links all samples to a cooler or shipping container. No entry for method blanks, LCS, and LCSD. This field is optional.	Text	25	NO
Temperature	<p>Temperature (in centigrade degrees) of the sample as received.</p> <p><u>This field is not required for radiochemistry methods.</u></p>	Numeric	10	NO

**Table 3**  
**Field Description for the Sample Analysis (A3 file)**

This table contains information related to analyses of field samples and laboratory QC samples (excluding calibrations and tunes) on a sample level for environmental chemical analyses including radiochemistry

Field Name	Field Name Description	Field Type	Field Length	Standard Value List
LabAnalysisRefMethodID	Laboratory reference method ID. The method ID may be an EPA Method number or laboratory identifier for a method such as a SOP number, however; values used for Laboratory Method IDs are specified by the project and must be contained in the standard value list for method IDs.	Text	25	YES (Specified by the project)
PreparationType	Preparation Method Number (i.e., 3010A, 3510C, 3550C, 5030B, etc.)  For analytical procedures that do not have a specific preparation method number, use "Gen Prep".	Text	25	YES (See Table 4)
AnalysisType	Defines the type of analysis such as initial analysis, dilution, re-analysis, etc. This field provides distinction for sample records when multiple analyses are submitted for the same sample, method, and matrix, for example: dilutions, re-analyses, and re-extracts.	Text	10	YES (See Table 4)
Prepared	<u>For radiochemistry leave this field blank.</u>  For all other methods enter the date and time of sample preparation or extraction. Refer to the date/time format at the end of this table.	Date/Time	16*	NO
Analyzed	<u>For radiochemistry methods</u> the date of sample analysis. Refer to the date format for radiochemistry methods at the end of this table.  <u>For all other methods</u> the date and time of sample analysis. Refer to the date and time format at the end of this table.	Date/Time	*	NO
LabID	Identification of the laboratory performing the analysis.	Text	7	NO
QCLevel	The level of laboratory QC associated with the analysis reported in the EDD. If only the Analytical Results Table (A1) and the Sample Analysis Table (A3) information are submitted for the sample, enter "COA". If the Laboratory Instrument Table (A2) information is also submitted for the sample, enter "COCAL"	Text	6	YES (See Table 4)
ResultBasis	Indicates whether results associated with this sample record are reported as wet or percent moisture corrected. This field is only required for soils and sediments. Enter "WET" if results are not corrected for percent moisture. Enter "DRY" if percent moisture correction is applied to results.	Text	3	YES (See Table 4)
TotalOrDissolved	This field indicates if the results related to this sample record are reported as a total or dissolved fraction. This field is only required for metal methods. For all other methods leave this field blank.	Text	3	YES (See Table 4)
Dilution	Dilution of the sample aliquot. Enter "1" for method blanks, LCS, and LCSD, or if the field samples was analyzed without dilution.	Numeric	10	NO
HandlingType	Indicates the type of leaching procedure, if applicable (i.e., SPLP, TCLP, WET).  Leave this field blank if the sample analysis was <u>not</u> performed on a leachate.	Text	10	YES (See Table 4)



**Table 3**  
**Field Description for the Sample Analysis (A3 file)**

This table contains information related to analyses of field samples and laboratory QC samples (excluding calibrations and tunes) on a sample level for environmental chemical analyses including radiochemistry

Field Name	Field Name Description	Field Type	Field Length	Standard Value List
HandlingBatch	<p>Unique laboratory identifier for a batch of samples prepared together in a leaching procedure (i.e., SPLP, TCLP, or WET preparation). The HandlingBatch links samples with leaching blanks.</p> <p>Leave this field blank if the sample analysis was <u>not</u> performed on a leachate</p>	Text	12	NO
LeachateDate	<p>Date and time of leaching procedure (i.e., date for SPLP, TCLP, or WET preparation). Refer to the date and time format at the end of this table.</p> <p>Leave this field blank if the sample analysis was <u>not</u> performed on a leachate</p>	Date /Time	16*	NO
Percent_Moisture	Percent of sample composed of water. Enter for soil and sediment samples only.	Numeric	10	NO
MethodBatch	<p>Unique laboratory identifier for a batch of samples of similar matrices analyzed by one method and treated as a group for matrix spike, matrix spike duplicate, or laboratory duplicate association</p> <p>The method batch links the matrix spike and/or matrix spike duplicate or laboratory duplicates to associated samples. Note, the MethodBatch association may coincide with the PreparationBatch association. The MethodBatch is specifically used to link the MS/MSD and/or DUP to associated samples.</p>	Text	12	NO
PreparationBatch	<p>Unique laboratory identifier for a batch of samples prepared together for analysis by one method and treated as a group for method blank, LCS and LCSD association.</p> <p>The PreparationBatch links method blanks and laboratory control samples (blank spikes) to associated samples. Note, the PreparationBatch association may coincide with the MethodBatch association but the PreparationBatch specifically links the Method Blank and LCS to associated samples.</p>	Text	12	NO
RunBatch	<p><u>For radiochemistry methods leave this field blank.</u></p> <p><u>For all other methods</u> the RunBatch is the unique identifier for a batch of analyses performed on one instrument under the control of one initial calibration and initial calibration verification. The RunBatch links both the initial calibration and initial calibration verification to subsequently analyzed and associated continuing calibrations, field samples, and QC analyses. For GC/MS methods, the RunBatch also links a BFB or DFTPP tune. A distinct RunBatch must used with every new initial calibration within a method</p> <p>The value entered in this field links a particular sample/method/analysis type record to a set of associated initial calibration and initial calibration verification records from Table A2.</p> <p>This field is only required if the A2 table is included with the EDD.</p>	Text	12	NO

**Table 3**  
**Field Description for the Sample Analysis (A3 file)**

This table contains information related to analyses of field samples and laboratory QC samples (excluding calibrations and tunes) on a sample level for environmental chemical analyses including radiochemistry

Field Name	Field Name Description	Field Type	Field Length	Standard Value List
AnalysisBatch	<p><u>For radiochemistry methods</u> leave this field blank.</p> <p><u>For all other methods</u> the AnalysisBatch is the unique identifier for a batch of analyses performed on one instrument and under the control of a continuing calibration or continuing calibration verification. The AnalysisBatch links the continuing calibration or calibration verification to subsequently analyzed and associated field sample and QC analyses. For GC/MS methods, the AnalysisBatch also links the BFB or DFTPP tune. A distinct AnalysisBatch must be used with every new continuing calibration or continuing calibration verification within a method</p> <p>The value entered in this field links a particular sample/method/analysis type record to a set of associated continuing calibration records in the Laboratory Instrument table.</p> <p>This field is only required if the A2 table is included with the EDD.</p>	Text	12	NO
LabReportingBatch	Unique laboratory identifier for the EDD. This is equivalent to the sample delivery group, lab work number, login ID, etc. The LabReportingBatch links all records in the EDD reported as one group. The value entered in this field must be the same in all records.	Text	12	NO
LabReceipt	Date and time the sample was received in the lab. A time value of 00:00 may be entered. Refer to the date/time format at the end of this table.	Date/Time	16*	
LabReported	Date and time hard copy reported delivered by the lab. A time value of 00:00 may be entered. Refer to the date/time format at the end of this table.	Date/Time	16*	

\* For radiochemistry methods format Date as MM/DD/YYYY (where MM = two digit month, DD = two digit day, and YYYY = four digit year)

For all other methods format Date and Time as MM/DD/YYYY hh:mm YYYY (where MM = two digit month, DD = two digit day, and YYYY = four digit year, hh = hour in 24 hour format, and mm = minutes)

**Table 4**  
**Standard Value List**

Field Name	Standard Value	Standard Value Description
Analysis_Type	DL	Dilution of the original sample
	DL2	Second dilution of the original sample
	DL3	Third dilution of the original sample
	DL4	Fourth dilution of the original sample
	RE	Reanalysis/re-extraction of sample
	RE2	Second reanalysis/re-extraction of sample
	RE3	Third reanalysis/re-extraction of sample
	RE4	Fourth reanalysis/re-extraction of the original sample
	RES	The initial or original sample.
Analyte_Name	Refer to QAPP and Project Library	Analyte names are specified by the project and entered into the library for each method and matrix. Analyte Names used in project libraries must first exist in the standard value table. The same holds true for the ClientAnalyteID
Analyte_Type	IS	Internal standard as defined per CLP usage
	SPK	Spiked analyte
	SURR	Surrogate as defined as per CLP usage
	TIC	Tentatively identified compound for GC/MS analysis
	TRG	Target compound
Detection_Limit_Type <sup>1</sup>	CRDL	Contract required detection limit
	IDL	Instrument detection limit
	MDA	Minimum detectable activity
	MDL	Method detection limit
Handling_Type <sup>2</sup>	WET	Wet leaching procedure
	SPLP	Synthetic Precipitation Leaching Procedure
	TCLP	Toxicity Characteristic Leaching Procedure
Lab_Analysis_Ref_Method_ID	Refer to QAPP and Project Library	Method IDs are specified by the project and entered into the library. Methods used in project libraries must first exist in the standard value table
Lab_Qualifiers <sup>3</sup>	*	INORG: Duplicate analysis was not within control limits
	*	ORG: Surrogate values outside of contract required QC limits
	+	INORG: Correlation coefficient for the method of standard additions (MSA) was less than 0.995
	A	ORG: Tentatively identified compound (TIC) was a suspected aldol-condensation product
	B	INORG: Value less than contract required detection limit but greater than or equal to instrument detection limit
	B	ORG: Compound is found in the associated blank as well as in the sample
	C	ORG: Analyte presence confirmed by GC/MS
	D	Result from an analysis at a secondary dilution factor
	E	INORG: Reported value was estimated because of the presence of interference
	E	ORG: Concentrations exceed the calibration range of the instrument
	H	Analysis performed outside method or client-specified holding time requirement
	J	Estimated value
	M	INORG: Duplicate injection precision was not met
	N	INORG: Spiked sample recovery was not within control limits
	N	ORG: Presumptive evidence of a compound
	P	ORG: Difference between results from two GC columns unacceptable (>25% Difference)
	S	Reported value was determined by the method of standard additions (MSA)
	U	Compound was analyzed for but not detected. Analyte result was below the Reporting Limit.
	W	INORG: Post digestion spike was out of control limits
X	Reserved for a lab-defined data qualifier	
Y	Reserved for a lab-defined data qualifier	
Z	Reserved for a lab-defined data qualifier	
Matrix_ID	AIR	Air
	AQ	Water
	ASH	Ash

## Table 4 Standard Value List

Field Name	Standard Value	Standard Value Description
Matrix_ID (continued)	BIOTA	Biological matter
	FILTER	Filter
	LIQUID	Non-aqueous liquid
	OIL	Oil
	SED	Sediment
	SLUDGE	Sludge
	SO	Soil
	SOLID	Non-soil/sediment solid
	TISSUE	Tissue
	WASTE	Waste
	WIPE	Wipe
Preparation_Type <sup>4</sup>	3005A	Acid Digestion of Waters for Total Recoverable or Dissolved Metals by FLAA or ICP
	3010A	Acid of Aqueous Samples and Extracts for Total Metals by FLAA or ICP
	3015	Microwave Assisted Acid Digestion of Aqueous Samples and Extracts
	3020A	Acid Digestion of Aqueous Samples and Extracts for Total Metals by GFAA
	3031	Acid Digestion of Oils for Metals Analysis by AA or ICP
	3050B	Acid Digestion of Sediments, Sludges, and Soils
	3051	Microwave Assisted Acid Digestion of Sediments, Sludges, Soils and Oils
	3052	Microwave Assisted Acid Digestion of Siliceous and Organically Based Matrices
	3060A	Alkaline Digestion for Hexavalent Chromium
	3510C	Separatory Funnel Liquid-Liquid Extraction
	3520C	Continuous Liquid-Liquid Extraction
	3535	Solid Phase Extraction
	3540C	Soxhlet Extraction
	3541	Automated Soxhlet Extraction
	3545	Pressurized Fluid Extraction
	3550B	Ultrasonic Extraction
	3560	Supercritical Fluid Extraction of Total Recoverable Petroleum Hydrocarbons
	5030B	Purge and Trap for Aqueous Samples
	5035	Closed-System Purge-and-Trap and Extraction for Volatile Organics in Soil and Waste Samples
	7470A	Acid digestion of waters for Mercury analysis
	7471A	Acid digestion of soils and solids for Mercury analysis
	Gen Prep	Generic preparation type when a preparation method ID does not exist (used mostly for general chemistry methods)
QC_Level	COA	Certificate of Analysis (accuracy and precision, no calibration)
	COACAL	Certificate of Analysis (accuracy and precision including calibration)
QC_Type	MB	Analytical control consisting of all reagents and standards that is carried through the entire procedure (Method Blank)
	CV	(Calibration Verification) Analytical standard run at a specified frequency to verify the calibration of the analytical system
	CCV	(Continuing Calibration Verification) Analytical standard run every 12 hours to verify the calibration of the GC/MS system
	DUP	A second aliquot of a sample that is treated the same as the original aliquot to determine the precision of the method
	IC	(Initial Calibration) Analysis of analytical standards for a series of different specified concentrations
	ICV	(Initial Calibration Verification) Analytical standard run at a specified frequency to verify the accuracy of the initial calibration of the analytical system
	IPC	(Instrument Performance Check) Analysis of DFTPP or BFB to evaluate the performance of the GC/MS system
	LCS	(Laboratory Control Sample) A control sample of known composition
	LCSD	(Laboratory Control Sample Duplicate) A duplicate control sample of known composition
	MS	(Matrix Spike) Aliquot of a matrix spiked with known quantities and subjected to the entire analytical procedure to measure recovery
	MSD	(Matrix Spike Duplicate) A second aliquot of the same matrix as the matrix spike that is spiked in order to determine the precision of the method
Reporting_Limit_Type <sup>1</sup>	CRDL	Contract required detection limit
	CRQL	Contract required quantitation limit

**Table 4**  
**Standard Value List**

Field Name	Standard Value	Standard Value Description
Reporting_Limit_Type (continued)	PQL	Practical quantitation limit
	SQL	Sample quantitation limit
	RDL	Reportable detection limit
Result_Basis	DRY	Result was calculated on a dry weight basis
	WET	Result was calculated on a wet weight basis
Result_Units <sup>5</sup>	ug/L	Micrograms per liter
	mg/L	Milligrams per liter
	ug/Kg	Micrograms per kilogram
	mg/Kg	Milligrams per kilogram
	pg/L	Picograms per liter
Total_Or_Dissolved	ng/Kg	Nanograms per kilogram
	DIS	Dissolved
	TOT	Total

- 1 Additional Detection Limit Types and Reporting Limit Types may be used. These must be added to the application standard values.
- 2 Additional Handling Types (leachate procedures) may be used. These must be added to the application standard values
- 3 Additional Lab Qualifiers may be used, or listed Lab Qualifiers may be used in a different manner than described in this table. New lab qualifiers must be added to the application standard value tables. NOTE: The “U” Lab Qualifier must be used for all non-detects.
- 4 Additional Preparation Types may be used. These must be added to the application standard value tables.
- 5 Additional Result Units may be used. The project library specifies the reporting limit used for each method and matrix

**Note:** If new standard values are used then these standard values must be entered in the software standard values for both the lab and contractor. The application will automatically update the standard values tables if an importing library contains standard values (method, client analyte ID, and analyte name) that do not exist in the software importing the new library.

**Table 5****Required Fields in the Analytical Results Table for GC/MS, GC, and HPLC Methods**

Field	GC/MS Methods			GC and HPLC Methods		
	Regular Sample*	MS/MSD	Method Blank, LCS/LCSD	Regular Sample*	MS/MSD	Method Blank, LCS/LCSD
Client_Sample_ID	X	X	X	X	X	X
Lab_Analysis_Ref_Method_ID	X	X	X	X	X	X
Analysis_Type	X	X	X	X	X	X
Lab_Sample_ID	X	X	X	X	X	X
Lab_ID	X	X	X	X	X	X
Client_Analyte_ID	X	X	X	X	X	X
Analyte_Name	X	X	X	X	X	X
Result	X	X	X	X	X	X
Result_Units	X	X	X	X	X	X
Lab_Qualifiers	Q	Q	Q	Q	Q	Q
Detection Limit	X	X	X	X	X	X
Detection_Limit_Type	X	X	X	X	X	X
Retention_Time	T		T			
Analyte_Type	X	X	X	X	X	X
Percent_Recovery	S	R	R	S	R	R
Relative_Percent_Difference		D	D		D	D
Reporting_Limit	X	X	X	X	X	X
Reporting_Limit_Type	X	X	X	X	X	X
Reportable_Result	X	X	X	X	X	X

**Key**

- X Required Field
- D Required field for spiked compounds in the LCSD and MSD only
- Q Required field if laboratory has qualified result. The "U" qualifier MUST be entered if the result is non-detect.
- R Required field if Analyte\_Type = "SPK" or "SURR"
- S Required field for surrogate compounds only
- T Required field for tentatively identified compounds by GC/MS only
- \* Also includes Equipment Blanks, Field Blanks, and Trip Blanks

**Table 6**  
**Required Fields in the Analytical Results Table for ICAP, AA, and IC Methods**

Field	ICAP and AA Methods			IC and Wet Chemistry Methods		
	Regular Sample*	Sample Duplicate, MS/MSD	Method Blank, LCS/LCSD	Regular Sample*	Sample Duplicate MS/MSD	Method Blank, LCS/LCSD
Client_Sample_ID	X	X	X	X	X	X
Lab_Analysis_Ref_Method_ID	X	X	X	X	X	X
Analysis_Type	X	X	X	X	X	X
Lab_Sample_ID	X	X	X	X	X	X
Lab_ID	X	X	X	X	X	X
Client_Analyte_ID	X	X	X	X	X	X
Analyte_Name	X	X	X	X	X	X
Result	X	X	X	X	X	X
Result_Units	X	X	X	X	X	X
Lab_Qualifiers	Q	Q	Q	Q	Q	Q
Detection Limit	X	X	X	X	X	X
Detection_Limit_Type	X	X	X	X	X	X
Retention_Time						
Analyte_Type	X	X	X	X	X	X
Percent_Recovery		S	S		S	S
Relative_Percent_Difference		R	R		R	R
Reporting_Limit	X	X	X	X	X	X
Reporting_Limit_Type	X	X	X	X	X	X
Reportable_Result	X	X	X	X	X	X

Key

- X Required field
- Q Required field if laboratory has qualified result. The “U” qualifier MUST be entered if the result is non-detect
- R Required field for spiked compounds in LCSD or MSD, or target compounds in the Sample Duplicate only
- S Required field if Analyte\_Type = “SPK”
- \* Also includes Trip Blanks, Equipment Blanks, and Field Blanks

**Table 7**  
**Required Fields in the Laboratory Instrument Table**

Field	GC/MS Tunes		Initial Calibration				Initial Calibration Verification				Calibration Verification, Continuing Calibration
	VOA	SVOA	GC/MS	GC HPLC	ICP/AA	IC*	GC/MS	GC HPLC	ICP/AA	IC*	ALL METHODS
Instrument_ID	X	X	X	X	X	X	X	X	X	X	X
QC_Type	X	X	X	X	X	X	X	X	X	X	X
Analyzed	X	X	X	X	X	X	X	X	X	X	X
Alternate_Lab_Analysis_ID	X	X	X	X	X	X	X	X	X	X	X
Lab_Analysis_ID	X	X					X	X	X	X	X
Lab_Analysis_Ref_Method_ID	X	X	X	X	X	X	X	X	X	X	X
Client_Analyte_ID	X	X	X	X	X	X	X	X	X	X	X
Analyte_Name	X	X	X	X	X	X	X	X	X	X	X
Run_Batch	X	X	X	X	X	X	X	X	X	X	X
Analysis_Batch	C	C									X
Lab_Reporting_Batch	X	X	X	X	X	X	X	X	X	X	X
Percent_Relative_Standard_Deviation			X	X							
Correlation_Coefficient			B	B	X	X					
Relative_Response_Factor			X				X				M
Percent_Difference							X	X	X	X	X
Peak_ID_01	X	X									
Percent_Ratio_01	X	X									
Peak_ID_02	X	X									
Percent_Ratio_02	X	X									
Peak_ID_03	X	X									
Percent_Ratio_03	X	X									
Peak_ID_04	X	X									
Percent_Ratio_04	X	X									
Peak_ID_05	X	X									
Percent_Ratio_05	X	X									
Peak_ID_06	X	X									
Percent_Ratio_06	X	X									
Peak_ID_07	X	X									
Percent_Ratio_07	X	X									
Peak_ID_08	X	X									
Percent_Ratio_08	X	X									
Peak_ID_09	X	X									
Percent_Ratio_09	X	X									
Peak_ID_10		X									
Percent_Ratio_10		X									
Peak_ID_11		X									
Percent_Ratio_11		X									
Peak_ID_12		X									
Percent_Ratio_12		X									
Peak_ID_13		X									
Percent_Ratio_13		X									

**Key**

- X Required field (some fields are not applicable to some General (Wet) Chemistry tests)
- B Required field if reporting best fit
- C Required field if BFB or DFTPP associated with a continuing calibration only
- M Required field for GC/MS continuing calibration only

\*IC Includes Ion Chromatography and Classical or Wet Chemistry methods. Methods such as pH, Conductivity, and others do not use traditional calibration procedures: therefore some fields marked as a required field under the "IC" column do not apply for these methods.



**Table 8**  
**Required Fields in the Sample Analysis Table**

Field	GC, GC/MS, HPLC Methods		ICAP and AA Methods		IC and Wet Chemistry Methods	
	Method Blanks, LCS/LCSD	Regular Samples*, Sample Duplicate, MS/MSD	Method Blanks, LCS/LCSD	Regular Samples*, Sample Duplicate, MS/MSD	Method Blanks, LCS/LCSD	Regular Samples*, Sample Duplicate, MS/MSD
Client_Sample_ID	X	X	X	X	X	X
Collected		X		X		X
Matrix_ID	X	X	X	X	X	X
Lab_Sample_ID	X	X	X	X	X	X
QC_Type	X	Q	X	Q	X	X
Shipping_Batch_ID		X		X		X
Temperature		X				X
Lab_Analysis_Ref_Method_ID	X	X	X	X	X	X
Preparation_Type	X	X	X	X	X	X
Analysis_Type	X	X	X	X	X	X
Prepared	A	A	X	X	N	N
Analyzed	X	X	X	X	X	X
Lab_ID	X	X	X	X	X	X
QC_Level	X	X	X	X	X	X
Results_Basis		S		S		S
Total_Or_Dissolved			W	W		
Dilution	X	X	X	X	X	X
Handling_Type	L	L	L	L	L	L
Handling_Batch	L	L	L	L	L	L
Leachate_Date	L	L	L	L	L	L
Percent Moisture		S		S		S
Method_Batch	X	X	X	X	X	X
Preparation_Batch	X	X	X	X	X	X
Run_Batch	C	C	C	C	C	C
Analysis_Batch	C	C	C	C	C	C
Lab_Reporting_Batch	X	X	X	X	X	X
Lab_Receipt		X		X		X
Lab_Reported	X	X	X	X	X	X

**Key**

- X Required field
- A Required field for samples prepared by methanol extraction
- C Required field if Instrument Calibration Table (A2) is included in EDD
- L Required field if analysis performed on SPLP, TCLP, or WET extracts
- N Required field only for samples that require preparation before analysis
- Q Required field for Sample Duplicate, MS, and MSD only
- S Required field if "Matrix\_ID" = "SO" or "SED"
- W Required field for aqueous samples only
- \* Includes Trip Blanks, Equipment Blanks, and Field Blanks

## Reviewed EDD Export File Specifications - Analytical Results (A1) Comma Delimited Text File

Order	Field Name*	Field Description
1	RecordID	Record number.
2	ClientSampleID	Client field sample identifier.
3	LabAnalysisRefMethodID	Laboratory reference method (i.e. 8260B, 6010B, etc.).
4	AnalysisType	Defines type of analysis (i.e. dilution, reanalysis, etc.).
5	LabSampleID	Internal laboratory sample tracking number for samples and lab generated QC.
6	LabID	Identifier of laboratory performing the analysis.
7	ClientAnalyteID	CAS number or unique analyte identifier.
8	AnalyteName	Chemical name for analyte.
9	Result	Reportable result for the analyte.
10	ResultUnits	Units of measure for the result (i.e. mg/Kg, ug/L, etc.).
11	LabQualifiers	A string of letter or symbol qualifiers assigned by the lab based on contractor defined rules and values.
12	DetectionLimit	Detection limit for the analyte being measured.
13	DetectionLimitType	Specifies the type of detection limit (i.e. MDL, IDL, etc.).
14	RetentionTime	The time expressed in decimal minutes between injection and detection for GC/MS TICs only.
15	AnalyteType	Defines the type of result such as surrogate, spike, or target analyte.
16	PercentRecovery	The percent recovery of a spiked QC compound such as a matrix spike, LCS spike, or surrogate.
17	RelativePercentDifference	RPD between to QC results such as MS/MSD.
18	ReportingLimit	Analyte reporting limit.
19	ReportingLimitType	Defines the type of reporting limit (PQL, CRQL, etc.).
20	ReportableResult	(YES or NO) Indicates which result is the useable result when results from two or more analyses for the same sample and method (ie dilutions, reanalyses, etc) are reported in the EDD.
21	Filename	File name of the EDD. The same as the LabReportingBatch in the Sample Analysis table (A3).
22	DVModifiedConcentration	ADR modified analyte result due to blank contamination.
23	DVQualTemperature	Data review qualifier for temperature outlier.
24	DVQualPreservation	Data review qualifier for preservation anomaly.
25	DVQualHTSamplingToAnalysis	Data review qualifier for holding time violation from sampling time to analysis time.
26	DVQualHTSamplingToExtraction	Data review qualifier for holding time violation from sampling time to extraction.
27	DVQualHTExtractionToAnalysis	Data review qualifier for holding time violation from extraction time to analysis time.
28	DVQualHoldingTime	Overall data review qualifier for holding time violation.
29	DVQualMethodBlanks	Data review qualifier for contamination in an associated method blank.
30	DVQualSurrogateRecovery	Data review qualifier for surrogate recovery outlier.
31	DVQualMS	Overall data review qualifier for associated MS and MSD recovery and/or RPD outlier.
32	DVQualMSRecovery	Data review qualifier for MS and/or MSD recovery outlier.
33	DVQualMSRPD	Data review qualifier for MS/MSD RPD outlier.
34	DVQualLCS	Overall data review qualifier for LCS and LCS recovery and/or RPD outlier.
35	DVQualLCSRecovery	Data review qualifier for associated LCS and/or LCSD recovery outlier.
36	DVQualLCSRPD	Data review qualifier for LCS/LCSD RPD outlier.
37	DVQualRepLimits	Data review qualifier for result reported below the reporting limit.
38	DVQualReportingLimits	Data review comment ("OutX") when reporting limit exceeds the project reporting limit.
39	DVQualFieldQC	Overall data review qualifier for Field QC.
40	DVQualFieldBlank	Data review qualifier for contamination in an associated Field Blank.
41	DVQualEquipmentBlank	Data review qualifier for contamination in an associated Equipment Rinsate or Equipment Blank.
42	DVQualTripBlank	Data review qualifier for contamination in an associated Trip Blank.
43	DVQualFieldDuplicate	Data review qualifier for an associated Field Duplicate RPD outlier.
44	DVQualIC	Overall data review qualifier for associated initial calibration outliers.
45	DVQualInitialCalibrationRRF	Data review qualifier for an associated initial calibration relative response

Order	Field Name*	Field Description
		factor outlier.
46	DVQualInitialCalibrationRSD	Data review qualifier for an associated initial calibration relative percent difference outlier.
47	DVQualInitialCalibrationCC	Data review qualifier for an associated initial calibration correlation coefficient outlier.
48	DVQualICV	Overall data review qualifier for an associated initial calibration verification.
49	DVQualInitialCalibrationVerificationRRF	Data review qualifier for an associated initial calibration verification relative response factor outlier.
50	DVQualInitialCalibrationVerificationPD	Data review qualifier for an associated initial calibration verification percent difference outlier.
51	DVQualCCV	Overall data review qualifier for associated continuing calibration outliers.
52	DVQualContinuingCalibrationVerificationRRF	Data review qualifier for an associated continuing calibration relative response factor outlier.
53	DVQualContinuingCalibrationVerificationPD	Data review qualifier for an associated continuing calibration percent difference outlier.
54	DVQualOverall	Overall data review qualifier for all QC and calibration qualifiers.
55	TagLabSampleID (see comment)	Temporary placeholder.
56	TagDetQual01 (see comment)	Temporary placeholder.
57	TagNonDetQual01 (see comment)	Temporary placeholder.
58	TagDetQual02 (see comment)	Temporary placeholder.
59	TagNonDetQual02 (see comment)	Temporary placeholder.
60	surDVQualDet (see comment)	Temporary placeholder.
61	surDVQualNonDet (see comment)	Temporary placeholder.
62	DVQualInstrumentPerformanceCheckRunBatch	Data review qualifier for GC/MS Tune outlier related to initial calibration.
63	DVQualInstrumentPerformanceCheckAnaBatch	Data review qualifier for GC/MS Tune outlier related to continuing calibration.
64	DVQualIPC	Overall data review qualifier for GC/MS tune outliers.
65	DVQualLabDup	Data review qualifier for RPD outlier in laboratory duplicate.
66	DVQualCode	User-defined Reason Code
67	FieldDupRPD	RPD calculated from Field duplicate and parent sample
68	DVQualMergedQualifier	Merged lab and data review qualifiers
69	DVQualMergedResult	Final result (modified concentration if applicable)
70	DVQualPercMoi <sup>1</sup>	Data review qualifier for percent moisture
71	DVQualLabDupNR <sup>1</sup>	Data review qualifier for laboratory duplicate not reported
72	DVQualLcsNR <sup>1</sup>	Data review qualifier for laboratory control sample(s) not reported
73	DVQualDissTotDiff <sup>1</sup>	Data review qualifier for dissolved and total fraction differing by more than 10%
74	Error	Radiochemistry error
75	DVQualSampleDupCount <sup>1</sup>	Data review qualifier for sample count being >20 in a duplicate batch
76	DVQualMsSampleCount <sup>1</sup>	Data review qualifier for sample count being >20 in a matrix spike batch
77	DVQualLcsCount <sup>1</sup>	Data review qualifier for sample count being >20 in a laboratory control sample batch
78	DVQualMbMissing <sup>1</sup>	Data review for missing method blank
79	DVQualPercMoiDissTotDiff <sup>1</sup>	Combined data review qualifier for percent moisture and total vs dissolved difference outliers
80	DVQualInternalStandard <sup>2</sup>	Data review qualifier for internal standard outlier
81	DVQualCalibrationBlank <sup>2</sup>	Data review qualifier for calibration blank contamination
82	DVQualRcm <sup>2</sup>	Data review qualifier for resolution check mixture problem
83	DVQualPem <sup>2</sup>	Data review qualifier for performance evaluation mixture problem
84	DVQualProfessionalJudgement <sup>2</sup>	Data review qualifier for any reason deemed necessary by data-review chemist
85	DOD_MDL	Method detection limit for QSM 4.2

Comment: Fields that contain temporary placeholders hold information contributed during the review process that is used in generating reports. This information is kept with the output file so that if the file is ever imported back into the application, reports can be generated without having to rerun the review module.

\* Field Names in bold font are added to the EDD during review and included in the exported reviewed EDD file

<sup>1</sup> Data review qualifiers in these cases are added for EPA Region II assessment. ADR.Net does not currently perform EPA Region II assessment.

<sup>2</sup> Data review qualifiers in these cases are added manually by the user and not assessed by automated data review.

## Reviewed EDD Export File Specifications - Sample Analysis (A3) Comma Delimited Text File

Order	Field Name*	Field Description
1	RecordID	Record number.
2	ProjectNumber	Project Number assigned by client.
3	ProjectName	Project Name assigned by client.
4	ClientSampleID	Client field sample identifier.
5	Collected	Date and time sample was collected.
6	MatrixID	Sample matrix.
7	LabSampleID	Internal laboratory sample tracking number for samples and lab generated QC.
8	QCType	Identifies the type of quality control sample, regular field samples are null.
9	ShippingBatchID	Unique identifier assigned to a cooler or shipping container used to transport field samples.
10	Temperature	Temperature in degrees C of the samples as received in the lab.
11	LabAnalysisRefMethodID	Laboratory reference method (i.e. 8260B, 6010B, etc.).
12	<b>PreparationType</b>	Preparation method number (i.e. 3010A, 3510C, etc.).
13	<b>AnalysisType</b>	Defines type of analysis (i.e. dilution, reanalysis, etc.).
14	<b>Prepared</b>	Date and time of sample preparation/extraction.
15	<b>Analyzed</b>	Date and time of sample analysis.
16	<b>LabID</b>	Identifier of laboratory performing analysis.
17	<b>QCLevel</b>	Level of analytical QC associated with analysis (i.e. Level III, etc.).
18	<b>ResultBasis</b>	Indicates if a result is expressed as wet or dry.
19	<b>TotalorDissolved</b>	Indicates if a result is expressed as total or dissolved (for metals only).
20	<b>Dilution</b>	Sample dilution during analysis.
21	<b>HandlingType</b>	Type of leaching procedure, if applicable (i.e. SPLP, TCLP, etc.).
22	<b>HandlingBatch</b>	Unique laboratory identifier for a batch of samples prepared together for a leaching procedure.
23	<b>LeachateDate</b>	Date and time of leaching procedure.
24	<b>PercentMoisture</b>	Percent moisture of sample.
25	<b>MethodBatch</b>	Unique laboratory identifier for a batch of samples with similar matrix and analyzed together by one method. Links samples to matrix spikes and duplicates.
26	<b>PreparationBatch</b>	Unique laboratory identifier for a batch of samples prepared together for analysis by one method. Links samples with method blanks and laboratory control samples.
27	<b>RunBatch</b>	Unique laboratory identifier for a batch of analyses performed on one instrument under the control of on an initial calibration. Links the initial calibration to associated samples.
28	<b>AnalysisBatch</b>	Unique laboratory identifier for a batch of analyses performed on one instrument under the control of a continuing calibration. Links continuing calibrations to associated samples.
29	<b>LabReportingBatch</b>	Unique laboratory identifier for a batch of samples, QC, and calibration standards reported as a group by the lab (i.e. order number, SDG #, etc.).
30	<b>LabReceipt</b>	Date samples received in laboratory.
31	<b>LabReported</b>	Date laboratory hardcopy submitted.
32	DataReviewCompany**	Company running the automated review software.
33	DataReviewDate	Date and time EDD was validated.
34	ValidatedBy**	Person running the automated review.
35	ValidationDate**	Date and time when automated data review qualifiers were reviewed
36	ApprovedBy**	Person performing secondary review of data review flags.
37	ApprovalDate**	Date and time of secondary review by "ApprovedBy".
38	FileName	File name of EDD (same as LabReportingBatch).
39	TagLabSampleID (see comment)	Temporary place holder.
40	TagDetQual (see comment)	Temporary place holder.
41	TagNonDetQual (see comment)	Temporary place holder.
42	TempFlag (see comment)	Temporary place holder.
43	LabMethodCategory	The category of the method, used by EDMS

Comment: Fields that contain temporary placeholders hold values created during the validation process. These values are used in generating reports. This information is kept with the output file so that if the file is ever imported back into the application, reports can be generated without having to rerun the validation module.

\* Field Names in bold font are added to the EDD during automated data review and included in the exported data-reviewed EDD file

\*\* Automated data review does not update these fields with any information but these fields are still part of the exported data-reviewed file. These fields may be populated manually by the user from various forms in the application prior to exporting.

\*\*\* Date/Time format: MM/DD/YYYY hh:mm

## **ATTACHMENT F**

Responses to Comments on the QAPP,  
Volume I, Appendix D, Draft Revision 4, Operable Unit 2 Landfills

## Responses to Comments submitted by Department of Toxic Substances Control (DTSC)<sup>1</sup>

**COMMENT 1:** QAPP Completeness. DTSC should not approve the document until the updated sections received in the email dated October 17, 2019 from Ahtna have been revised in accordance with Comment #2b are incorporated into the QAPP and the complete document is submitted to DTSC.

**RESPONSE TO COMMENT 1:** *The updated information provided in the email sent to the U.S. Army Corps of Engineers, the U.S. Environmental Protection Agency, the DTSC, and the Central Coast Regional Water Quality Control Board on October 16, 2019 was incorporated into the draft final version of the Quality Assurance Project Plan (QAPP), to which these responses to comments are attached.*

**COMMENT 2:** TO-15 Analyte List Reduction.

- a. The TTU Influent Testing did not detect 1,1,1-trichloroethane, 1,3-butadiene, trans-1,3-dichloropropene, or bromodichloromethane above their respective laboratory reporting limits during the last five annual monitoring events. In accordance with California Code of Regulations, Title 27, §21160, the operator may request a reduction in monitoring activities based upon the results of monitoring data collected with concurrence from the overseeing agency. Therefore, pursuant to the decision rules presented in the QAPP, and GSU review of the proposal, the removal for these analytes from the TO-15 TAL is supportable. In addition, none of the four analytes proposed for no further monitoring are listed as Chemicals of Concern (COCs) in the ROD, allowing this reduction of the TAL to occur. Listed COCs cannot be removed from the TAL as codified in the ROD.

**RESPONSE TO COMMENT 2a:** *QAPP Worksheet #15, Section 3.6.3 was revised to remove 1,1,1-trichloroethane, 1,3-butadiene, trans-1,3-dichloropropene, and bromodichloromethane from the target analyte list (TAL) for thermal treatment unit (TTU) source testing and operational influent landfill gas testing per the comment.*

- b. The updated Section 3.6.4 received from Ahtna in the email date October 17, 2019 for the Compliance Perimeter Probes proposed the following analytes to be removed from the TAL: 1,2,4-Trimethylbenzene, 1,3,5-Trimethylbenzene, 4-Ethyltoluene, Cyclohexane, Ethyl Benzene, and O-Xylene. However, each of these constituents were detected as noted in the 2015 Final Annual Report Operations and Maintenance Operable Unit 2 Landfills (Ahtna, 2015) disqualifying their removal from the TAL. Only four monitoring events have passed since the 2015 detections. Section 3.6.4 should be revised accordingly.

**RESPONSE TO COMMENT 2b:** *QAPP Worksheet #15, Section 3.6.4 is the TAL for compliance probes only, which is based on the analytical approach for compliance probes described in QAPP Worksheet #11, Section 3.2.3, Data Quality Objective #3. The analytes listed in the comment were detected in SGP-4E-12, which is a monitoring probe and not a compliance probe, as stated in Note 1 to Table 2-1 of the Final Annual Report, 2015 Operations and Maintenance, Operable*

---

<sup>1</sup> In a letter dated November 6, 2019 (see Administrative Record No. [OUCTP-702I.3](#)).



Unit 2 Landfills, Former Fort Ord California.<sup>2</sup> *Based on the analytical approach for compliance probes described in QAPP Worksheet #11, these analytes do qualify for removal from the compliance probe TAL.*

**COMMENT 3:** Addition of Field Sampling Procedure and Updated Laboratory Analyses Certificate. The additional field sampling procedure and the updated laboratory analyses certification are complete.

**RESPONSE TO COMMENT 3:** *Comment acknowledged.*

---

<sup>2</sup> See Administrative Record No. [OU2-703](#).